

















Kawasaki

KX450F



Motorcycle Service Manual

Quick Reference Guide

General Information	1	
Periodic Maintenance	2	
Fuel System	3	
Cooling System	4	
Engine Top End	5	
Engine Right Side	6	
Engine Lubrication System	7	
Engine Removal/Installation	8	
Crankshaft/Transmission	9	
Wheels/Tires	10	
Final Drive	11	
Brakes	12	
Suspension	13	
Steering	14	
Frame	15	
Electrical System	16	
Appendix	17	

This quick reference guide will assist you in locating a desired topic or procedure.

- Bend the pages back to match the black tab of the desired chapter number with the black tab on the edge at each table of contents page.
- Refer to the sectional table of contents for the exact pages to locate the specific topic required.



Kawasaki

KX450F

Motorcycle Service Manual

All rights reserved. No parts of this publication may be reproduced, stored in a retrieval system, or transmitted in any form or by any means, electronic mechanical photocopying, recording or otherwise, without the prior written permission of Quality Assurance Division/Consumer Products & Machinery Company/Kawasaki Heavy Industries, Ltd., Japan.

No liability can be accepted for any inaccuracies or omissions in this publication, although every possible care has been taken to make it as complete and accurate as possible.

The right is reserved to make changes at any time without prior notice and without incurring an obligation to make such changes to products manufactured previously. See your Motorcycle dealer for the latest information on product improvements incorporated after this publication.

All information contained in this publication is based on the latest product information available at the time of publication. Illustrations and photographs in this publication are intended for reference use only and may not depict actual model component parts.

LIST OF ABBREVIATIONS

A	ampere(s)	lb	pound(s)
ABDC	after bottom dead center	m	meter(s)
AC	alternating current	min	minute(s)
ATDC	after top dead center	N	newton(s)
BBDC	before bottom dead center	Pa	pascal(s)
BDC	bottom dead center	PS	horsepower
BTDC	before top dead center	psi	pound(s) per square inch
°C	degree(s) Celsius	r	revolution
DC	direct current	r/min, rpm	revolution(s) per minute
F	farad(s)	TDC	top dead center
°F	degree(s) Fahrenheit	TIR	total indicator reading
ft	foot, feet	V	volt(s)
g	gram(s) (mass)	W	watt(s)
h	hour(s)	Ω	ohm(s)
kg	(mass)		
kgf	(force)		
L	liter(s)		

Foreword

This manual is designed primarily for use by trained mechanics in a properly equipped shop. However, it contains enough detail and basic information to make it useful to the owner who desires to perform his own basic maintenance and repair work. A basic knowledge of mechanics, the proper use of tools, and workshop procedures must be understood in order to carry out maintenance and repair satisfactorily. Whenever the owner has insufficient experience or doubts his ability to do the work, all adjustments, maintenance, and repair should be carried out only by qualified mechanics.

In order to perform the work efficiently and to avoid costly mistakes, read the text, thoroughly familiarize yourself with the procedures before starting work, and then do the work carefully in a clean area. Whenever special tools or equipment are specified, do not use makeshift tools or equipment. Precision measurements can only be made if the proper instruments are used, and the use of substitute tools may adversely affect safe operation.

To get the longest life out of your vehicle:

- Follow the Periodic Maintenance Chart in the Service Manual.
- Be alert for problems and non-scheduled maintenance.
- Use proper tools and genuine Kawasaki Motorcycle parts. Special tools, gauges, and testers that are necessary when servicing Kawasaki motorcycles are introduced by the Service Manual. Genuine parts provided as spare parts are listed in the Parts Catalog.
- Follow the procedures in this manual carefully. Don't take shortcuts.
- Remember to keep complete records of maintenance and repair with dates and any new parts installed.

How to Use This Manual

In this manual, the product is divided into its major systems and these systems make up the manual's chapters. The Quick Reference Guide shows you all of the product's system and assists in locating their chapters. Each chapter in turn has its own comprehensive Table of Contents.

For example, if you want ignition coil information, use the Quick Reference Guide to locate the Electrical System chapter. Then, use the Table of Contents on the first page of the chapter to find the Ignition Coil section.

Whenever you see these WARNING and CAUTION symbols, heed their instructions! Always follow safe operating and maintenance practices.

▲ WARNING

This warning symbol identifies special instructions or procedures which, if not correctly followed, could result in personal injury, or loss of life.

CAUTION

This caution symbol identifies special instructions or procedures which, if not strictly observed, could result in damage to or destruction of equipment.

This manual contains four more symbols (in addition to WARNING and CAUTION) which will help you distinguish different types of information.

NOTE

○ *This note symbol indicates points of particular interest for more efficient and convenient operation.*

- Indicates a procedural step or work to be done.
- Indicates a procedural sub-step or how to do the work of the procedural step it follows. It also precedes the text of a NOTE.
- ★ Indicates a conditional step or what action to take based on the results of the test or inspection in the procedural step or sub-step it follows.

In most chapters an exploded view illustration of the system components follows the Table of Contents. In these illustrations you will find the instructions indicating which parts require specified tightening torque, oil, grease or a locking agent during assembly.

General Information



Table of Contents

Before Servicing	1-2
Model Identification.....	1-7
General Specifications.....	1-8
Unit Conversion Table	1-10

1-2 GENERAL INFORMATION

Before Servicing

Before starting to perform an inspection service or carry out a disassembly and reassembly operation on a motorcycle, read the precautions given below. To facilitate actual operations, notes, illustrations, photographs, cautions, and detailed descriptions have been included in each chapter wherever necessary. This section explains the items that require particular attention during the removal and reinstallation or disassembly and reassembly of general parts.

Especially note the following:

Edges of Parts

Lift large or heavy parts wearing gloves to prevent injury from possible sharp edges on the parts.

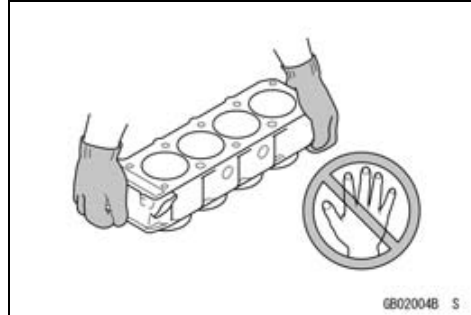

Solvent

Use a high-flash point solvent when cleaning parts. High-flash point solvent should be used according to directions of the solvent manufacturer.

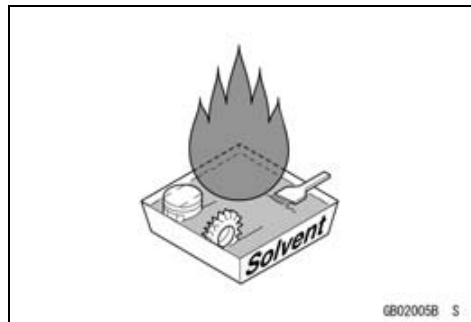

Cleaning vehicle before disassembly

Clean the vehicle thoroughly before disassembly. Dirt or other foreign materials entering into sealed areas during vehicle disassembly can cause excessive wear and decrease performance of the vehicle.

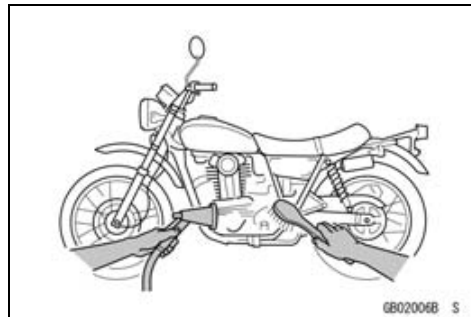

Arrangement and Cleaning of Removed Parts

Disassembled parts are easy to confuse. Arrange the parts according to the order the parts were disassembled and clean the parts in order prior to assembly.

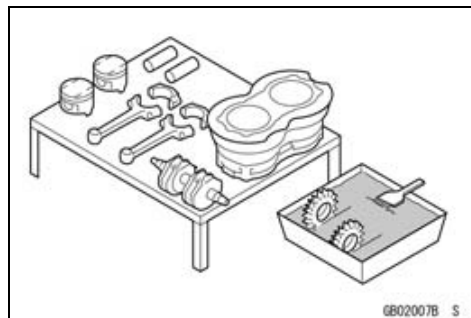

Before Servicing

Storage of Removed Parts

After all the parts including subassembly parts have been cleaned, store the parts in a clean area. Put a clean cloth or plastic sheet over the parts to protect from any foreign materials that may collect before re-assembly.

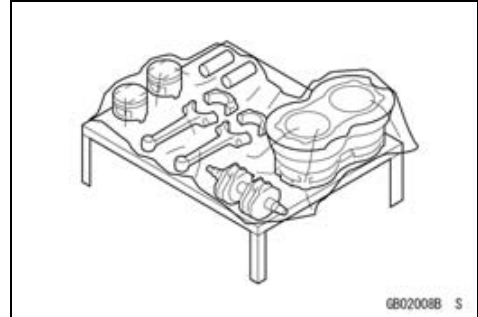

GB02008B S

Inspection

Reuse of worn or damaged parts may lead to serious accident. Visually inspect removed parts for corrosion, discoloration, or other damage. Refer to the appropriate sections of this manual for service limits on individual parts. Replace the parts if any damage has been found or if the part is beyond its service limit.

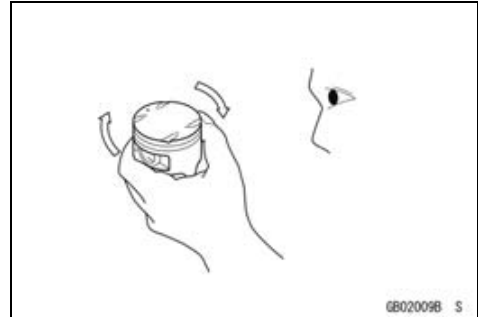

GB02009B S

Replacement Parts

Replacement Parts must be KAWASAKI genuine or recommended by KAWASAKI. Gaskets, O-rings, Oil seals, Grease seals, circlips or cotter pins must be replaced with new ones whenever disassembled.

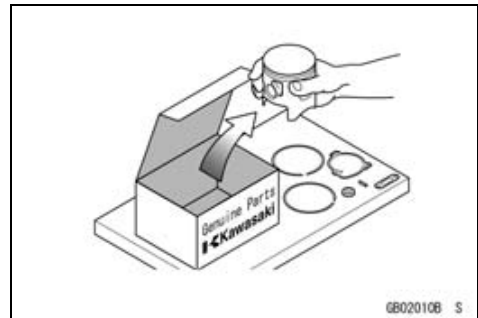

GB02010B S

Assembly Order

In most cases assembly order is the reverse of disassembly, however, if assembly order is provided in this Service Manual, follow the procedures given.

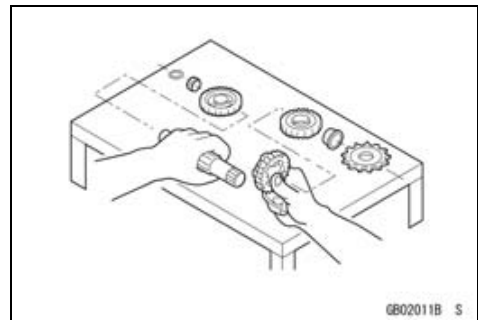

GB02011B S

Tightening Sequence

Generally, when installing a part with several bolts, nuts, or screws, start them all in their holes and tighten them to a snug fit. Then tighten them according to the specified sequence to prevent case warpage or deformation which can lead to malfunction. Conversely when loosening the bolts, nuts, or screws, first loosen all of them by about a quarter turn and then remove them. If the specified tightening sequence is not indicated, tighten the fasteners alternating diagonally.

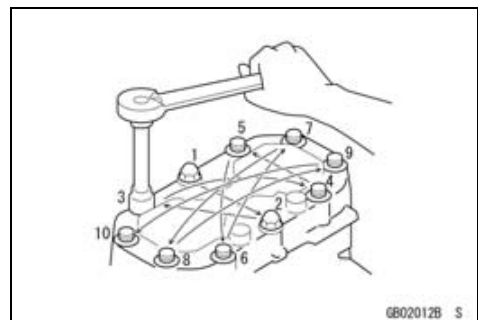

GB02012B S

1-4 GENERAL INFORMATION

Before Servicing

Tightening Torque

Incorrect torque applied to a bolt, nut, or screw may lead to serious damage. Tighten fasteners to the specified torque using a good quality torque wrench.

Often, the tightening sequence is followed twice-initial tightening and final tightening with torque wrench.

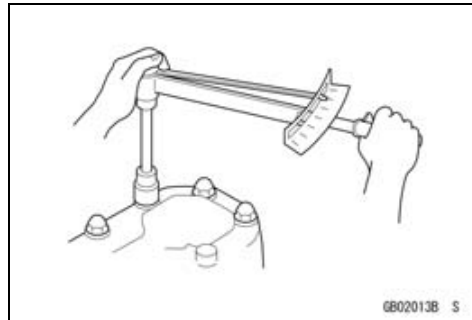

Force

Use common sense during disassembly and assembly, excessive force can cause expensive or hard to repair damage. When necessary, remove screws that have a non-permanent locking agent applied using an impact driver. Use a plastic-faced mallet whenever tapping is necessary.

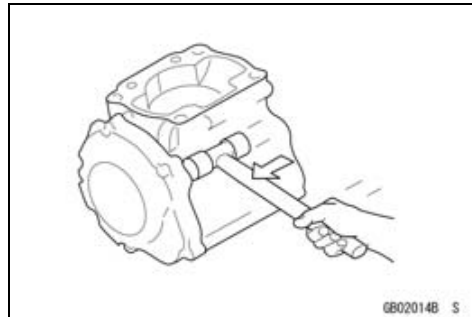

Gasket, O-ring

Hardening, shrinkage, or damage of both gaskets and O-rings after disassembly can reduce sealing performance. Remove old gaskets and clean the sealing surfaces thoroughly so that no gasket material or other material remains. Install new gaskets and replace used O-rings when re-assembling.

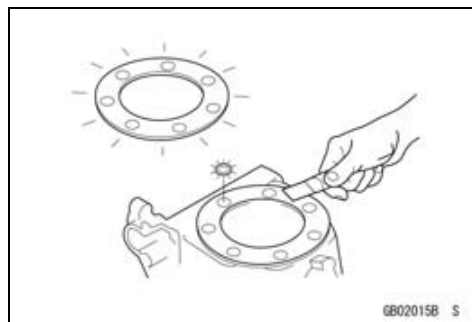

Liquid Gasket, Non-permanent Locking Agent

For applications that require Liquid Gasket or a Non-Permanent Locking Agent, clean the surfaces so that no oil residue remains before applying liquid gasket or non-permanent locking agent. Do not apply them excessively. Excessive application can clog oil passages and cause serious damage.



Press

For items such as bearings or oil seals that must be pressed into place, apply small amount of oil to the contact area. Be sure to maintain proper alignment and use smooth movements when installing.

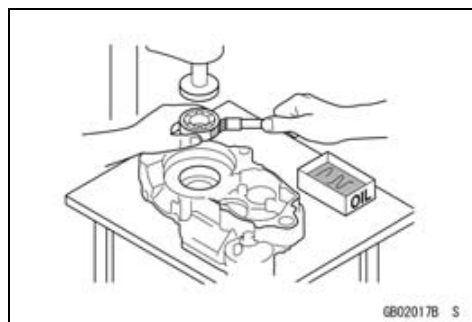

Before Servicing

Ball Bearing and Needle Bearing

Do not remove pressed ball or needle unless removal is absolutely necessary. Replace with new ones whenever removed. Press bearings with the manufacturer and size marks facing out. Press the bearing into place by putting pressure on the correct bearing race as shown.

Pressing the incorrect race can cause pressure between the inner and outer race and result in bearing damage.

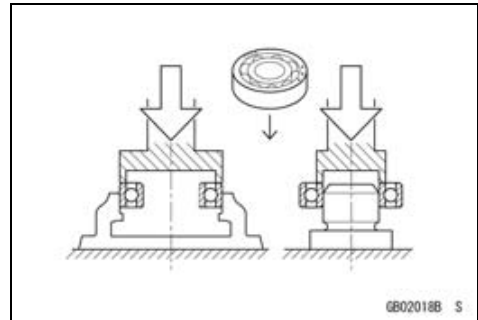

Oil Seal, Grease Seal

Do not remove pressed oil or grease seals unless removal is necessary. Replace with new ones whenever removed. Press new oil seals with manufacture and size marks facing out. Make sure the seal is aligned properly when installing.

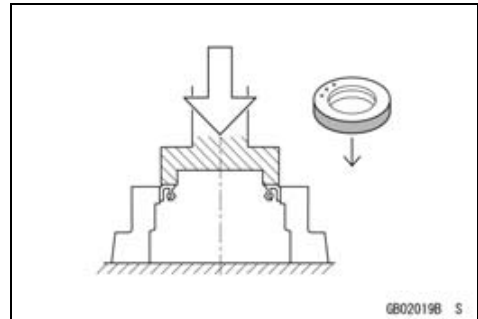

Apply specified grease to the lip of seal before installing the seal.

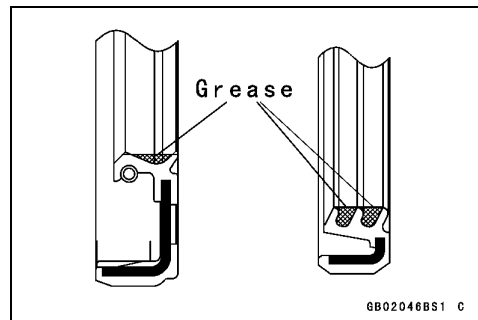

Circlips, Cotter Pins

Replace circlips or cotter pins that were removed with new ones. Take care not to open the clip excessively when installing to prevent deformation.

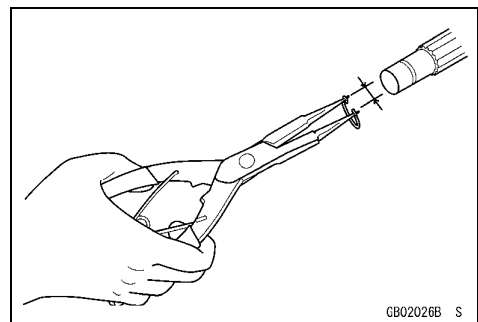

Lubrication

It is important to lubricate rotating or sliding parts during assembly to minimize wear during initial operation. Lubrication points are called out throughout this manual, apply the specific oil or grease as specified.



1-6 GENERAL INFORMATION

Before Servicing

Direction of Engine Rotation

When rotating the crankshaft by hand, the free play amount of rotating direction will affect the adjustment. Rotate the crankshaft to positive direction (clockwise viewed from output side).

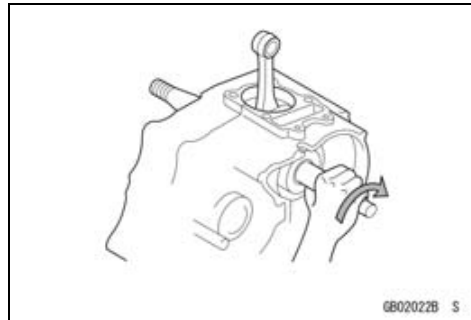

Electrical Leads

A two-color lead is identified first by the primary color and then the stripe color. Unless instructed otherwise, electrical leads must be connected to those of the same color.

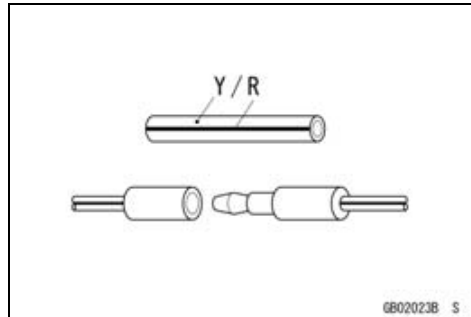

Instrument

Use a meter that has enough accuracy for an accurate measurement. Read the manufacturer's instructions thoroughly before using the meter. Incorrect values may lead to improper adjustments.

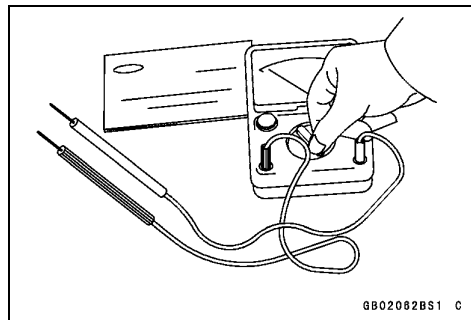

Model Identification

KX450D6F Left Side View



KX450D6F Right Side View



1-8 GENERAL INFORMATION

General Specifications

Items	KX450D6F ~ D8F
Dimensions Overall Length Overall Width Overall Height Wheelbase Road Clearance Seat Height Dry Mass Fuel Tank Capacity	2 185 mm (86.02 in.) 820 mm (32.3 in.) 1 280 mm (50.39 in.) 1 485 mm (58.46 in.) 345 mm (13.6 in.) 965 mm (38.0 in.) 99.8 kg (220 lb) 7.2 L (1.9 US gal)
Performance Minimum Turning Radius	–
Engine Type Cooling System Bore and Stroke Displacement Compression Ratio Carburetion System Starting System Ignition System Timing Advance Ignition Timing Spark Plug Valve Timing: Inlet: Open Close Duration Exhaust: Open Close Duration Lubrication System Engine Oil: Grade Viscosity Capacity	4-stroke, single cylinder, DOHC 4 valve Liquid-cooled 96.0 × 62.1 mm (3.78 × 2.44 in.) 449 cm ³ (27.4 cu in.) 12.0 : 1 Carburetor, KEIHIN FCR40 Primary kick Digital AC-CDI BTDC 10° @1 800 r/min (rpm) NGK CPR8EB-9 BTDC 32° (KX450D6F), BTDC 36° (KX450D7F ~) ABDC 72° (KX450D6F), ABDC 68° (KX450D7F ~) 284° BBDC 62° (KX450D6F), BBDC 66° (KX450D7F ~) ATDC 42° (KX450D6F), ATDC 38° (KX450D7F ~) 284° Forced lubrication (semi-dry sump) API SG, SH, SJ or SL with JASO MA SAE 10W-40 1.2 L (1.3 US qt)
Drive Train Primary Reduction System: Type Reduction Ratio Clutch Type	Gear 2.727 (60/22) Wet, multi disc

General Specifications

Items	KX450D6F ~ D8F
Transmission: Type Gear ratios: 1st 2nd 3rd 4th 5th Final Drive System: Type Reduction Ratio Overall Drive Ratio	4-speed, constant mesh, return shift (KX450D6F) 5-speed, constant mesh, return shift (KX450D7F ~) 1.800 (27/15) (KX450D6F), 1.750 (28/16) (KX450D7F ~) 1.411 (24/17) 1.187 (19/16) 1.000 (19/19) 0.875 (21/24) Chain drive 3.4846 (50/13) 10.489 @Top gear (KX450D6F) 9.178 @Top gear (KX450D7F ~)
Frame Type Steering Angle Caster (rake angle) Trail Front tire: Size Make/Type Rear tire: Size Make/Type Rim size: Front Rear Front suspension: Type Wheel travel Rear suspension: Type Wheel travel Brake type: Front and Rear Effective disc diameter: Front (effect. dia.) Rear (effect. dia.)	Tubular, semi-double cradle 42° to either side 27.1° 117 mm (4.60 in.) 90/100-21 57M DUNLOP D742F, Tube type 120/80-19 63M DUNLOP D756, Tube type 21 × 1.60 19 × 2.15 Telescopic fork (up side down) 315 mm (12.4 in.) Swingarm (New Uni-trak) 315 mm (12.4 in.) Single disc 225 mm (8.86 in.) 215 mm (8.46 in.)

Specifications subject to change without notice, and may not apply to every country.

1-10 GENERAL INFORMATION

Unit Conversion Table

Prefixes for Units:

Prefix	Symbol	Power
mega	M	× 1 000 000
kilo	k	× 1 000
centi	c	× 0.01
milli	m	× 0.001
micro	μ	× 0.000001

Units of Mass:

kg	×	2.205	=	lb
g	×	0.03527	=	oz

Units of Volume:

L	×	0.2642	=	gal (US)
L	×	0.2200	=	gal (imp)
L	×	1.057	=	qt (US)
L	×	0.8799	=	qt (imp)
L	×	2.113	=	pint (US)
L	×	1.816	=	pint (imp)
mL	×	0.03381	=	oz (US)
mL	×	0.02816	=	oz (imp)
mL	×	0.06102	=	cu in

Units of Force:

N	×	0.1020	=	kgf
N	×	0.2248	=	lb
kgf	×	9.807	=	N
kgf	×	2.205	=	lb

Units of Length:

km	×	0.6214	=	mile
m	×	3.281	=	ft
mm	×	0.03937	=	in

Units of Torque:

N·m	×	0.1020	=	kgf·m
N·m	×	0.7376	=	ft·lb
N·m	×	8.851	=	in·lb
kgf·m	×	9.807	=	N·m
kgf·m	×	7.233	=	ft·lb
kgf·m	×	86.80	=	in·lb

Units of Pressure:

kPa	×	0.01020	=	kgf/cm ²
kPa	×	0.1450	=	psi
kPa	×	0.7501	=	cm Hg
kgf/cm ²	×	98.07	=	kPa
kgf/cm ²	×	14.22	=	psi
cm Hg	×	1.333	=	kPa

Units of Speed:

km/h	×	0.6214	=	mph
------	---	--------	---	-----

Units of Power:

kW	×	1.360	=	PS
kW	×	1.341	=	HP
PS	×	0.7355	=	kW
PS	×	0.9863	=	HP

Units of Temperature:

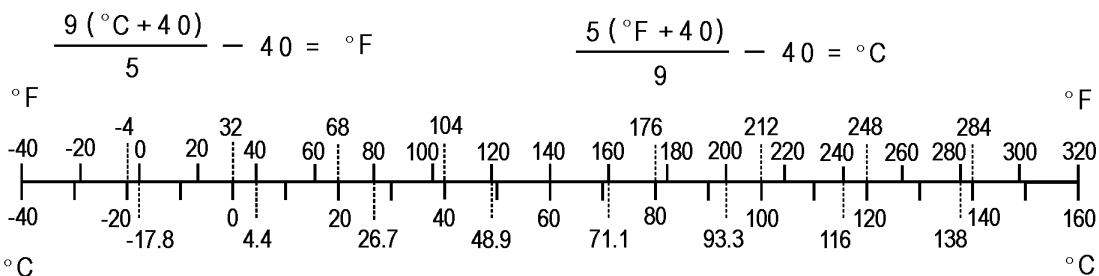

Periodic Maintenance

Table of Contents

Periodic Maintenance Chart	2-3	Oil Filter Change	2-27
Torque and Locking Agent.....	2-5	Breather Hose Inspection	2-28
Specifications	2-9	Crankshaft/Transmission	2-29
Special Tools	2-11	Crankshaft Inspection	2-29
Periodic Maintenance Procedures.....	2-12	Wheel/Tires.....	2-29
Fuel System.....	2-12	Air Pressure Inspection/Adjustment	2-29
Fuel Hose and Connections		Tires Inspection.....	2-30
Inspection.....	2-12	Spoke Tightness Inspection	2-30
Throttle Grip (Throttle Cable) Free		Rim Runout Inspection.....	2-31
Play Inspection.....	2-12	Wheel Bearing Inspection	2-31
Throttle Grip (Throttle Cable) Free		Final Drive.....	2-32
Play Adjustment	2-12	Drive Chain Slack Inspection	2-32
Hot Starter Lever (Hot Starter		Drive Chain Slack Adjustment	2-32
Cable) Free Play Inspection.....	2-13	Drive Chain Wear Inspection	2-33
Idle Speed Inspection	2-13	Drive Chain Lubrication.....	2-34
Idle Speed Adjustment.....	2-14	Sprocket Wear Inspection.....	2-34
Air Cleaner Element Cleaning and		Rear Sprocket Warp (Runout)	
Inspection.....	2-14	Inspection.....	2-35
Fuel System Cleaning.....	2-16	Brakes.....	2-35
Fuel Tank, Filter and Tap		Brake Lever and Pedal Position	
Cleaning.....	2-17	Adjustment	2-35
Fuel Tap and Filter Inspection.....	2-17	Brake Fluid Level Inspection.....	2-36
Cooling System.....	2-17	Brake Fluid Change	2-37
Coolant Level Inspection.....	2-18	Brake Pad Wear Inspection	2-39
Coolant Deterioration Inspection..	2-19	Brake Master Cylinder Cup and	
Water Hoses and Connections		Dust Cover Replacement	2-39
Inspection.....	2-19	Brake Caliper Fluid Seal and Dust	
Engine Top End	2-19	Seal Replacement.....	2-41
Valve Clearance Inspection	2-19	Brake Hoses and Connections	
Valve Clearance Adjustment.....	2-20	Inspection.....	2-44
Cylinder Head Warp Inspection ...	2-22	Brake Hose Replacement	2-44
Cylinder Wear Inspection.....	2-23	Suspension	2-45
Piston/Cylinder Clearance		Front Fork Inspection	2-45
Inspection.....	2-23	Front Fork Oil Change (each fork	
Piston, Piston Ring and Piston		leg) (KX450D6F ~ D7F)	2-45
Pin Replacement.....	2-23	Front Fork Oil Change (each fork	
Exhaust System Inspection.....	2-24	leg) (KX450D8F)	2-54
Muffler Baffle Change	2-24	Rear Shock Absorber Inspection .	2-63
Engine Right Side	2-25	Rear Shock Absorber Oil Change	2-63
Clutch Lever (Clutch Cable) Free		Swingarm and Uni-Trak Linkage	
Play Inspection.....	2-25	Inspection.....	2-68
Clutch Lever (Clutch Cable) Free		Swingarm and Uni-Track Linkage	
Play Adjustment	2-25	Pivot Lubrication.....	2-68
Clutch Plates Inspection	2-26	Steering	2-68
Engine Lubrication System	2-26	Steering Inspection	2-68
Engine Oil Change.....	2-26		

2-2 PERIODIC MAINTENANCE

Steering Adjustment	2-68	Spark Plug Replacement	2-71
Steering Stem Bearing Lubrication.....	2-70	General Lubrication and Cable Inspection.....	2-72
Frame	2-70	General Lubrication.....	2-72
Frame Inspection	2-70	Cable Inspection	2-73
Electrical System	2-71	Nut, Bolt, and Fastener Tightness Inspection.....	2-73
Spark Plug Cleaning and Inspection.....	2-71	Tightness Inspection	2-73

Periodic Maintenance Chart

The maintenance must be done in accordance with this chart to keep the motorcycle in good running condition.

OPERATION		FREQUENCY				See Page
		Each race or 2.5 hr	Every 3 races or 7.5 hr	Every 6 races or 15 hr	Every 12 races or 30 hr	
E N G I N E	Spark plug-clean, inspect †	•				2-71
	Spark plug-replace		•			2-71
	Clutch cable-inspect and adjust	•				2-25
	Clutch plates-inspect †	•				2-26
	Throttle cable-inspect and adjust	•				2-12
	Air cleaner element-clean †	•				2-14
	Air cleaner element-replace		If damaged			2-14
	Carburetor-inspect and adjust	•				2-13
	Engine Oil-change			•		2-26
	Piston and piston ring-replace		Every 6 races			2-23
	Cylinder head, cylinder-inspect			•		2-22
	Piston pin-replace				•	2-23
	Valve clearance-inspect †			•		2-19
	Hot starter cable-inspect	•				2-13
	Oil filter-replace			•		2-27
	Exhaust System-inspect †	•				2-24
	Muffler Baffle-change		•			2-24
	Kick pedal and shift pedal-clean	•				–
	Engine sprocket-inspect †	•				2-34
	Coolant level- inspect†	•				2-18
Water hoses and connections-inspect †	•				2-19	
Crankshaft-inspect			•		2-29	
Breather hose-inspect	•				2-28	
C H A S S I S	Brake adjustment-inspect †	•				2-35
	Brake-adjust †	•				2-39
	Brake fluid level-inspect †	•				2-36
	Brake fluid-change		Every 2 years			2-37
	Brake master cylinder cup and dust cover-replace		Every 2 years			2-39
	Brake caliper fluid seal and dust seal-replace		Every 2 years			2-41
	Brake hoses and pipe-replace		Every 4 years			2-44
	Brake hoses, connections-inspect †	•				2-44
	Spoke tightness and rim runout-inspect †	•				2-30
	Wheel bearing-inspect †	•				2-31
Frame-inspect and clean	•				2-70	
Drive chain wear-inspect †	•				2-33	
Drive chain-inspect and adjust	•				2-32	

2-4 PERIODIC MAINTENANCE

Periodic Maintenance Chart

OPERATION	FREQUENCY				See Page
	Each race or 2.5 hr	Every 3 races or 7.5 hr	Every 6 races or 15 hr	Every 12 races or 30 hr	
Drive chain-lubricate	•				2-34
Wheels/tires-inspect	•				2-29
Rear sprocket-inspect †	•				2-35
Front fork-inspect and clean	•				2-45
Front fork oil-change			•		2-45
Rear shock absorber oil-change			•		2-63
Cable-inspect	•				2-73
Fuel hose-replace	Every 4 years				2-12
Fuel hose, connections-inspect †	•				2-12
Fuel system-clean		•			2-16
Steering play-inspect †	•				2-68
Steering stem bearing-lubricate			•		2-70
Swingarm and Uni-Trak linkage pivots-lubricate		•			2-68
Swingarm and Uni-Trak linkage pivots-inspect †		•			2-68
Nuts, bolts, fasteners-inspect †	•				2-73
General Lubrication-perform	•				2-72

†: Replace, add, adjust, clean or torque if necessary.

Torque and Locking Agent

Tighten all bolts and nuts to the proper torque using an accurate torque wrench. If insufficiently tightened, a bolt or nut may become damaged, strip an internal thread, or break and then fall out. The following table lists the tightening torque for the major bolts and nuts, and the parts requiring use of a non-permanent locking agent or liquid gasket.

When checking the tightening torque of the bolts and nuts, first loosen the bolt or nut by half a turn and then tighten to specified torque.

Letters used in the "Remarks" column mean:

AL: Tighten the two clamp bolts alternately two times to ensure even tightening torque.

G: Apply grease.

L: Apply a non-permanent locking agent to the threads.

MO: Apply molybdenum disulfide oil (mixture of engine oil and molybdenum disulfide grease with a weight ratio 10 : 1).

Lh: Left-hand Threads

S: Tighten the fasteners following the specified sequence.

O: Apply 2-stroke oil.

Fastener	Torque			Remarks
	N·m	kgf·m	ft·lb	
Fuel System				
Throttle Pulley Cover Bolt	3.4	0.35	30 in·lb	
Throttle Cable Mounting Bolts	6.9	0.70	61 in·lb	
Air Cleaner Duct Clamp Screw	2.0	0.20	17 in·lb	
Air Cleaner Duct Mounting Nuts	3.0	0.31	27 in·lb	
Air Cleaner Duct Mounting Bolt	3.0	0.31	27 in·lb	
Air Cleaner Housing Bolts	9.8	1.0	87 in·lb	
Cooling System				
Water Pump Cover Bolts	9.8	1.0	87 in·lb	
Water Pump Impeller Bolt	9.8	1.0	87 in·lb	
Water Hose Clamp Screws	1.5	0.15	13 in·lb	
Coolant Drain Bolt	6.9	0.70	61 in·lb	
Radiator Mounting Bolts	9.8	1.0	87 in·lb	
Radiator Screen Bolts	9.8	1.0	87 in·lb	
Radiator Shroud Bolts	9.8	1.0	87 in·lb	
Engine Top End				
Cylinder Head Cover Bolts	9.8	1.0	87 in·lb	
Cylinder Head Bolts (M10)	59	6.0	44	S, MO
Cylinder Head Bolts (M6)	12	1.2	104 in·lb	S
Camshaft Cap Bolts	9.8	1.0	87 in·lb	S, MO
Camshaft Sprocket Bolts	12	1.2	104 in·lb	L
Decompressor Plug Plate Bolt	9.8	1.0	87 in·lb	
Water Hose Fitting Bolts	9.8	1.0	87 in·lb	
Oil Line Plug	3.0	0.31	27 in·lb	L
Carburetor Holder Clamp Screws	2.0	0.20	17 in·lb	
Plug	20	2.0	15	L
Lower Camshaft Chain Guide Bolt	9.8	1.0	87 in·lb	
Rear Camshaft Chain Guide Bolt	15	1.5	11	
Chain Tensioner Mounting Bolts	9.8	1.0	87 in·lb	
Chain Tensioner Cap Bolt	5.0	0.51	44 in·lb	

2-6 PERIODIC MAINTENANCE

Torque and Locking Agent

Fastener	Torque			Remarks
	N·m	kgf·m	ft·lb	
Cylinder Bolt	12	1.2	104 in·lb	S
Exhaust Pipe Cover Screws	12	1.2	104 in·lb	
Exhaust Pipe Holder Nuts	21	2.1	15	
Muffler Mounting Bolts	21	2.1	15	
Muffler Pipe Mounting Bolts	–	–	–	L
Engine Right Side				
Primary Gear Nut	98	10	72	Lh
Shift Drum Cam Bolt	24	2.4	17	L
Clutch Spring Bolts	8.8	0.90	78 in·lb	
Clutch Hub Nut	98	10	72	
Gear Set Lever Nut	8.8	0.90	78 in·lb	
Ratchet Plate Mounting Bolt	9.8	1.0	87 in·lb	S
Ratchet Plate Mounting Screw (KX450D6F)	6.4	0.65	57 in·lb	S, L
Ratchet Plate Mounting Bolt (KX450D7F ~)	15	1.5	11	S, L
Ratchet Guide Bolt	8.8	0.90	78 in·lb	
Kick Pedal Bolt	25	2.5	18	L
Shift Pedal Bolt	9.8	1.0	87 in·lb	
Clutch Cover Bolts	9.8	1.0	87 in·lb	
Right Engine Cover Bolts	9.8	1.0	87 in·lb	
Engine Lubrication System				
Engine Oil Drain Bolt (M10) (for transmission room oil sump)	20	2.0	15	
Engine Oil Drain Bolt (M6) (for crank room oil sump)	7.0	0.71	62 in·lb	
Oil Pump (Scavenge) Cover Bolts	9.8	1.0	87 in·lb	S
Oil Pump (Feed) Cover Bolts	9.8	1.0	87 in·lb	S
Oil Filter Cover Bolt	9.8	1.0	87 in·lb	
Oil Screen (Feed) Mounting Bolts	9.8	1.0	87 in·lb	
Oil Pressure Relief Valve	15	1.5	11	L
Piston Oil Nozzle	2.9	0.30	26 in·lb	
Breather Fitting	15	1.5	11	L
Engine Removal/Installation				
Engine Mounting Bolt, Nuts	49	5.0	36	
Engine Bracket Bolt, Nuts	29	3.0	21	
Swingarm Pivot Shaft Nut	98	10	72	
Crankshaft/Transmission				
Piston Oil Nozzle (KX450D6F ~ D7F)	2.9	0.30	26 in·lb	
Piston Oil Nozzle (KX450D8F)	4.0	0.41	35 in·lb	
Crankcase Bolts (M6)	12	1.2	104 in·lb	S
Crankcase Bolts (M7)	15	1.5	11	S

Torque and Locking Agent

Fastener	Torque			Remarks
	N·m	kgf·m	ft·lb	
Engine Oil Drain Bolt (M10) (for transmission room oil sump)	20	2.0	15	
Engine Oil Drain Bolt (M6) (for crank room oil sump)	7.0	0.71	62 in·lb	
Bearing Retaining Screw	15	1.5	11	L
Gear Set Lever Nut	8.8	0.90	78 in·lb	
Shift Drum Cam Bolt	24	2.4	17	L
Balancer Weight Mounting Nut	52	5.3	38	
Gear Position Switch Screws	2.9	0.30	26 in·lb	L
Wheels/Tires				
Front Axle	78	80	58	
Front Axle Clamp Bolts	20	2.0	15	AL
Rear Axle Nut	108	11	80	
Spoke Nipples	Not less than 2.2	Not less than 0.22	Not less than 19 in·lb	
Final Drive				
Rear Sprocket Nuts	34	3.5	25	
Engine Sprocket Nut	127	13	94	
Engine Sprocket Cover Bolts	9.8	1.0	87 in·lb	
Brakes				
Brake Lever Pivot Bolt Locknut	5.9	0.60	52 in·lb	
Brake Reservoir Cap Screws (Front)	1.5	0.15	13 in·lb	
Brake Lever Pivot Bolt	5.9	0.60	52 in·lb	
Caliper Mounting Bolts (Front)	25	2.5	18	
Brake Hose Banjo Bolts	25	2.5	18	
Front Master Cylinder Clamp Bolts	8.8	0.90	78 in·lb	S
Rear Master Cylinder Mounting Bolts	9.8	1.0	87 in·lb	
Rear Master Cylinder Push Rod Locknut	17	1.7	13	
Brake Reservoir Cap Bolts (Rear)	1.5	0.15	13 in·lb	
Brake Disc Mounting Bolts:				
(Front)	9.8	1.0	87 in·lb	L
(Rear)	23	2.3	17	L
Caliper Bleed Valves (Front, Rear)	7.8	0.80	69 in·lb	
Caliper Holder Shaft (Rear)	27	2.8	20	
Brake Pad Bolt	17	1.7	13	
Rear Brake Pad Bolt Plug	2.5	0.25	22 in·lb	
Brake Pedal Mounting Bolt	25	2.5	18	L, G
Suspension				
Front Fork Clamp Bolts				
(Upper)	20	2.0	15	AL
(Lower)	20	2.0	15	AL
Front Fork Top Plug	30	3.1	22	
Adjuster Assembly	58	5.9	43	L

2-8 PERIODIC MAINTENANCE

Torque and Locking Agent

Fastener	Torque			Remarks
	N·m	kgf·m	ft·lb	
Base Valve Assembly	28	2.9	21	
Locknut/Adjuster Assembly	29	3.0	21	
Swingarm Pivot Shaft Nut	98	10	72	
Rear Shock Absorber Mounting Nuts:				
(Upper)	39	4.0	29	
(Lower)	34	3.5	25	
Air Bleed Bolt	6.4	0.65	56 in·lb	
Tie-Rod Mounting Nut (Front, Rear) (KX450D6F)	83	8.5	61	
Tie-Rod Mounting Nut (Front, Rear) (KX450D7F ~)	59	6.0	43	
Rocker Arm Pivot Nut (KX450D6F)	83	8.5	61	
Rocker Arm Pivot Nut (KX450D7F ~)	59	6.0	43	
Steering				
Steering Stem Head Nut	98	10	72	
Steering Stem Nut	4.9	0.50	43 in·lb	
Handlebar Holder Bolts	25	2.5	18	O
Frame				
Rear Frame Mounting Bolts	34	3.5	25	
Upper Footpeg Bracket Bolts	54	5.5	40	L
Electrical System				
Gear Position Switch Screws	2.9	0.30	26 in·lb	L
Flywheel Nut	78	8.0	58	
Stator Bolts	4.0	0.41	35 in·lb	L
Crankshaft Sensor Bolts	7.0	0.71	62 in·lb	
Spark Plug	13	1.3	113 in·lb	
C.D.I. Unit Bolts	9.8	1.0	87 in·lb	
Magneto Cover Bolts	9.8	1.0	87 in·lb	
Breather Fitting	15	1.5	11	L
Ignition Coil Bolts	7.0	0.71	62 in·lb	

Basic Torque for General Fasteners

Threads dia. (mm)	Torque		
	N·m	kgf·m	ft·lb
5	3.4 ~ 4.9	0.35 ~ 0.50	30 ~ 43 in·lb
6	5.9 ~ 7.8	0.60 ~ 0.80	52 ~ 69 in·lb
8	14 ~ 19	1.4 ~ 1.9	10.0 ~ 13.5
10	25 ~ 34	2.6 ~ 3.5	19.0 ~ 25
12	44 ~ 61	4.5 ~ 6.2	33 ~ 45
14	73 ~ 98	7.4 ~ 10.0	54 ~ 72
16	115 ~ 155	11.5 ~ 16.0	83 ~ 115
18	165 ~ 225	17.0 ~ 23.0	125 ~ 165
20	225 ~ 325	23 ~ 33	165 ~ 240

Specifications

Item	Standard	Service Limit
Fuel System		
Throttle Grip Free Play	2 ~ 3 mm (0.08 ~ 0.12 in.)	---
Hot Starter Lever Free Play	0.5 ~ 1.0 mm (0.02 ~ 0.04 in.)	---
Air Cleaner Element Oil	High quality foam air filter oil	---
Cooling System		
Coolant:		
Type (recommended)	Permanent type antifreeze	
Color	Green	
Mixed Ratio	Soft water 50% and coolant 50%	
Freezing Point	-35 °C (-31 °F)	
Total Amount	1.05 L (1.11 US qt)	
Engine Top End		
Valve Clearance:		
Exhaust	0.17 ~ 0.22 mm (0.0067 ~ 0.0087 in.)	---
Inlet	0.10 ~ 0.15 mm (0.0039 ~ 0.0059 in.)	---
Cylinder Head Warp	---	0.05 mm (0.002 in.)
Cylinder Inside Diameter (see text)	96.000 ~ 96.012 mm (3.7795 ~ 3.7800 in.)	96.10 mm (3.783 in.)
Piston/cylinder Clearance	0.020 ~ 0.042 mm (0.00079 ~ 0.0016 in.)	---
Engine Right Side		
Clutch Lever Free Play	8 ~ 13 mm (0.3 ~ 0.5 in.)	---
Friction Plate Thickness	2.92 ~ 3.08 mm (0.115 ~ 0.121 in.)	2.6 mm (0.10 in.)
Friction Plate Warp	0.15 mm (0.0059 in.) or less	0.3 mm (0.01 in.)
Steel Plate Warp	0.2 mm (0.008 in.) or less	0.3 mm (0.01 in.)
Engine Lubrication System		
Engine oil:		
Grade	Castrol "R4 superbike" 5W-40 (KX450D6F ~ D7F), Castrol "POWER1 R4 Racing" 5W-40 (KX450D8F) or API SG, SH, SJ or SL with JASO MA	
Viscosity	SAE 10W-30, 10W-40, or 10W-50	
Capacity	1.2 L (1.3 US qt)	
Crankshaft/Transmission		
Connecting Rod Big End Side Clearance	0.25 ~ 0.35 mm (0.0098 ~ 0.014 in.)	0.6 mm (0.02 in.)
Wheels/Tires		
Rim Runout (with tire installed):		
Axial	TIR 1.0 mm (0.039 in.) or less	TIR 2 mm (0.08 in.)
Radial	TIR 1.0 mm (0.039 in.) or less	TIR 2 mm (0.08 in.)
Front and Rear Tires Air Pressure	100 kPa (1.0 kgf/cm ² , 14 psi)	---

2-10 PERIODIC MAINTENANCE

Specifications

Item	Standard	Service Limit
Standard Tire:		
Front:		
Size	90/100-21 57M	---
Make	DUNLOP	
Type	D742F, Tube	
Rear:		
Size	120/80-19 63M	---
Make	DUNLOP	
Type	D756, Tube	
Final Drive		
Drive Chain Slack	52 ~ 58 mm (2.0 ~ 2.3 in.)	---
Drive Chain 20 Link Length	317.5 ~ 318.2 mm (12.50 ~ 12.53 in.)	323 mm (12.7 in.)
Rear Sprocket Warp (Runout)	TIR 0.4 mm (0.016 in.) or less	TIR 0.5 mm (0.020 in.)
Brakes		
Brake Lever Free Play	(to suit rider)	---
Brake Fluid:		
Type:		
Front	DOT3 or DOT4	---
Rear	DOT4	---
Brake pad lining thickness:		
Front	3.8 mm (0.15 in.)	1 mm (0.04 in.)
Rear	6.4 mm (0.25 in.)	1 mm (0.04 in.)
Suspension		
Fork Oil:		
Oil Viscosity	KHL15-10 (KAYABA 01) or equivalent	---
Oil Quantity:		(Adjustable range)
Outer (Outer/Inner Tubes)	345 mL (11.7 US oz.) (KX450D6F)	325 ~ 365 mL (11.0 ~ 12.3 US oz.) (KX450D6F)
	355 mL (12.0 US oz.) (KX450D7F)	330 ~ 380 mL (11.2 ~ 12.8 US oz.) (KX450D7F ~)
	350 mL (11.8 US oz.) (KX450D8F)	(EUR) 330 ~ 370 mL (11.2 ~ 12.5 US oz.) (KX450D6F)
	(EUR) 350 mL (11.8 US oz.) (KX450D6F)	
Inner (Subtank)	170 mL (5.75 US oz.) (KX450D6F) 191 mL (6.46 US oz.) (KX450D7F ~)	---
Rear Shock Absorber Oil:		
Oil Viscosity	K2-C (KAYABA) or equivalent	---
Electrical System		
Spark Plug Gap	0.8 ~ 0.9 mm (0.03 ~ 0.04 in.)	---

TIR: Total Indicator Readings

EUR: Europe Model

Special Tools

Inside Circlip Pliers:
57001-143

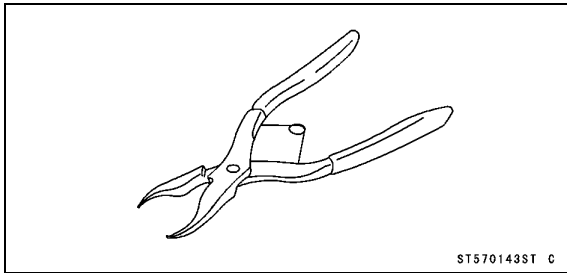

ST570143ST C

Pilot Screw Adjuster Adapter, $\phi 4$:
57001-1371

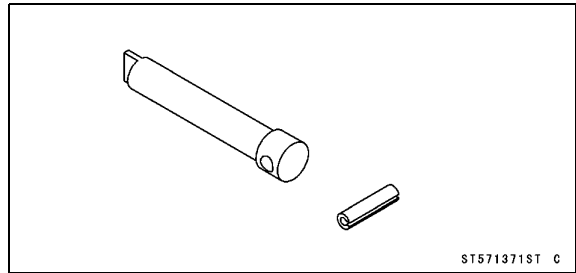

ST571371ST C

Steering Stem Nut Wrench:
57001-1100

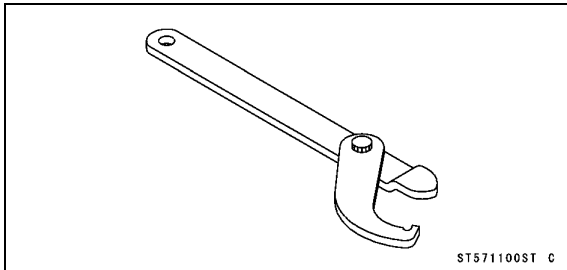

ST571100ST C

Filler Cap Driver:
57001-1454

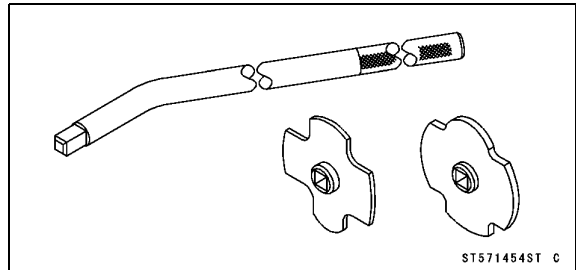

ST571454ST C

Jack:
57001-1238

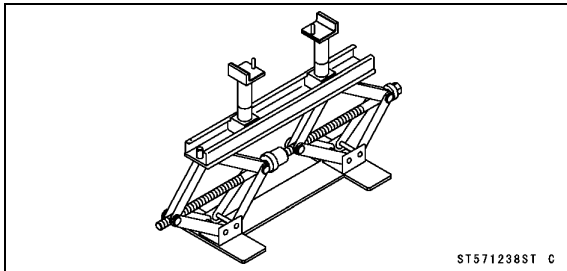

ST571238ST C

Pilot Screw Adjust, D:
57001-1588

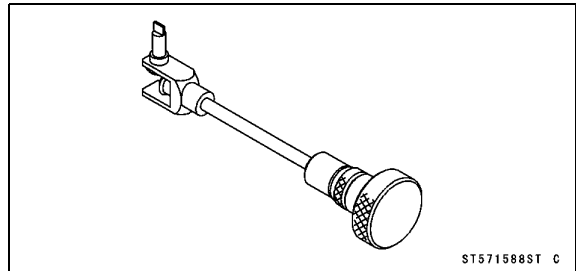

ST571588ST C

Spark Plug Wrench, Hex 16:
57001-1262

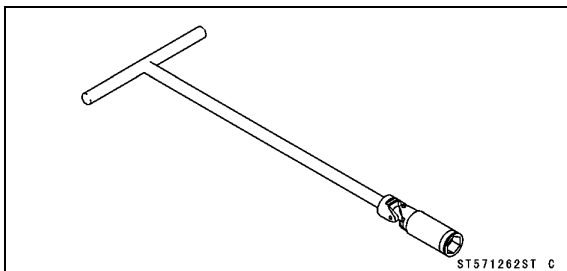

ST571262ST C

Top Plug Wrench, 49 mm:
57001-1653

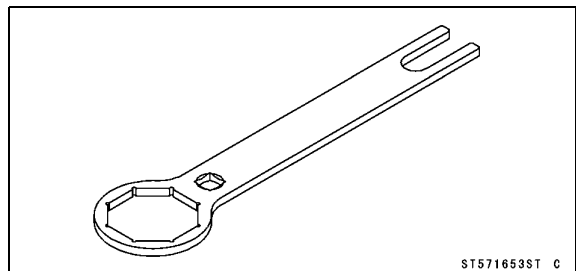

ST571653ST C

Pilot Screw Adjuster, C:
57001-1292

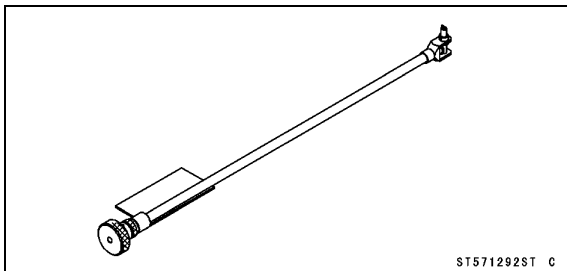

ST571292ST C

Top Plug Wrench, 36 mm:
57001-1705

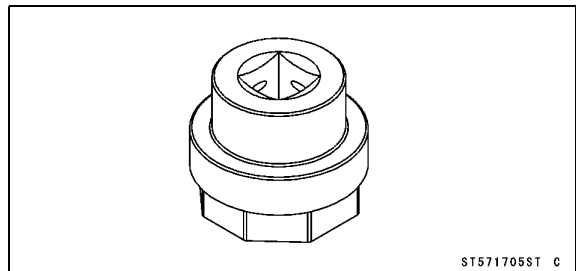

ST571705ST C

2-12 PERIODIC MAINTENANCE

Periodic Maintenance Procedures

Fuel System

Fuel Hose and Connections Inspection

○ The fuel hoses are designed to be used throughout the motorcycle's life without any maintenance, however, if the motorcycle is not properly handled, the inside the fuel line can cause fuel to leak [A] or the hose to burst.

- Check the fuel hose.
- ★ Replace the fuel hose if any fraying, cracks [B], bulges [C] or ozone cracks [D] are noticed.

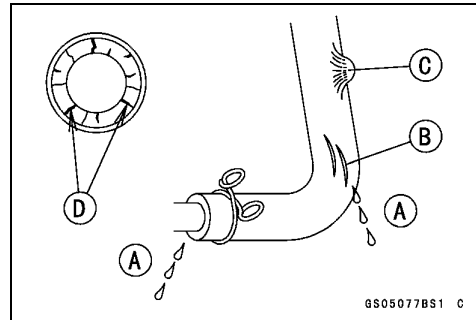

- Check that the hose [A] are securely connected and clamps [B] are tightened correctly.
- When installing, route the hose according to Cable, Wire, and Hose Routing section in the Appendix chapter.
- When installing the fuel hose, avoid sharp bending, kinking, flattening or twisting, and route the fuel hose with a minimum of bending so that the fuel flow will not be obstructed.
- ★ Replace the hose if it has been sharply bent or kinked.

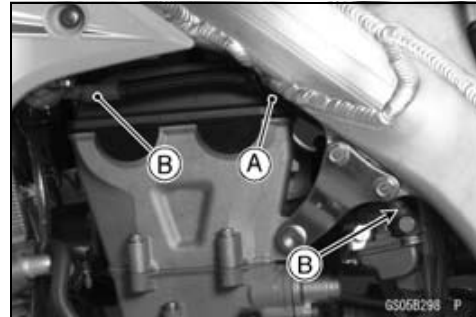

Throttle Grip (Throttle Cable) Free Play Inspection

- Check throttle grip free play [B] by lightly turning the throttle grip [A] back and forth.
- ★ If the free play is improper, adjust the throttle cable.

Throttle Grip Free Play

Standard: 2 ~ 3 mm (0.08 ~ 0.12 in.)

- Check that the throttle grip moves smoothly from full open to close, and the throttle closes quickly and completely in all steering positions by the return spring.
- ★ If the throttle grip does not return properly, check the throttle cable routing, grip free play, and cable damage. Then lubricate the throttle cable.
- Run the engine at the idle speed, and turn the handlebar all the way to the right and left to ensure that the idle speed does not change.
- ★ If the idle speed increase, check the throttle cable free play and the cable routing.

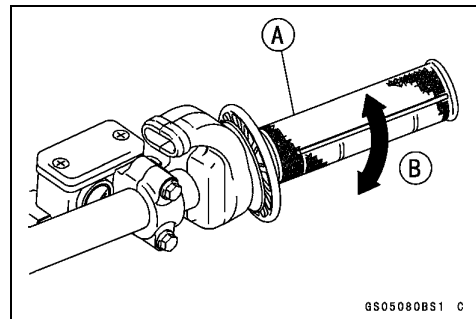

Throttle Grip (Throttle Cable) Free Play Adjustment

- Loosen the locknuts [A] [B] at the upper end of the throttle cable.
- Screw both throttle cable adjuster [C] [D] to give the throttle grip plenty of play.
- Turn out the decelerator adjuster [C] until there is no play when the throttle grip is completely closed.
- Tighten the locknut [A].
- Turn the accelerator cable adjuster [D] until 2 ~ 3 mm (0.08 ~ 0.12 in.) of throttle grip play is obtained.
- Tighten the locknut [B].

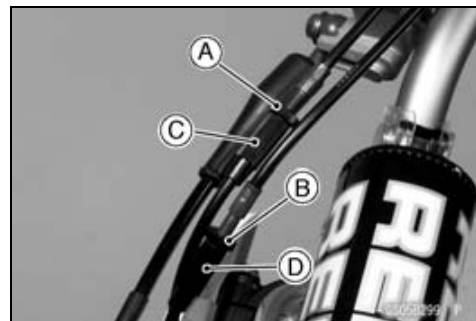

⚠ WARNING

Operation with an improperly adjusted, incorrectly routed, or damaged cable could result in an unsafe riding condition.

Periodic Maintenance Procedures

Hot Starter Lever (Hot Starter Cable) Free Play Inspection

- Slide the clutch lever dust cover [A] back.
- Check the hot starter lever play [B] when pulling the start lever [C] lightly.

Hot Starter Lever Free Play

Standard: 0.5 ~ 1.0 mm (0.02 ~ 0.04 in.)

★ If the free play is improper, adjust the hot starter cable.

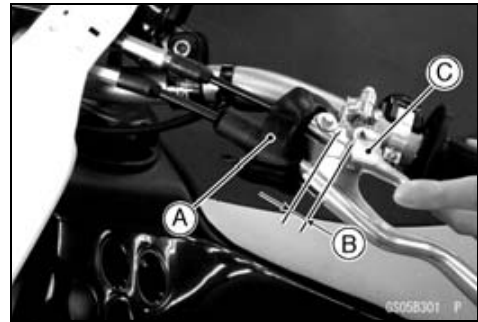

- Slide the adjuster cover [A] back.
- Loosen the locknut [B] and turn the adjuster [C] to obtain the proper lever free play.
- Tighten the locknut securely.
- Check that the hot starter lever moves smoothly from full open to close, and the lever closes quickly and completely in all steering positions by the return spring.
- ★ If the hot starter lever does not return properly, check the hot starter cable routing, free play and cable damage. Then lubricate the hot starter cable.

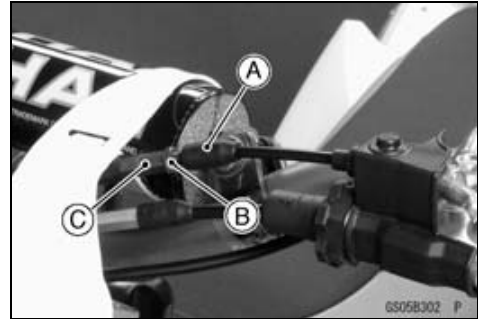

Idle Speed Inspection

CAUTION

This motorcycle is designed for competition use only. Therefore, the radiator does not incorporate a coolant reserve tank or cooling fan. Prolonged idling of the engine with no airflow through the radiator can cause coolant loss and engine overheating resulting in possible engine damage. Any riding conditions that increase engine temperature will further reduce idling time before coolant loss occurs. These conditions include high ambient temperature, sandy or muddy terrain, or other conditions causing high engine loads at low speeds. Furthermore, warming the engine up excessively before operation, or leaving idling with the hot engine temperature after operation results in the engine overheating, too.

- Start the engine and warm it up thoroughly.
- With the engine idling, turn the handlebar to both sides [A].
- ★ If handlebar movement changes the idle speed, the throttle cable may be improperly adjusted or incorrectly routed, or it may be damaged. Be sure to correct any of these conditions before riding (see Cable, Wire, and Hose Routing section in the Appendix chapter).

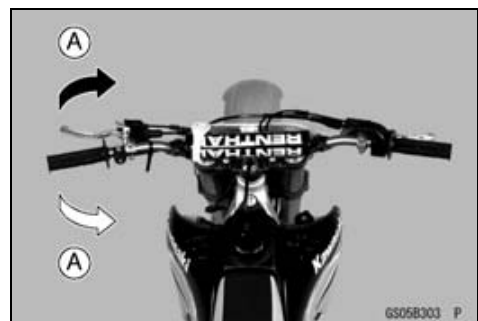

⚠ WARNING

Operation with an improperly adjusted, incorrectly routed, or damaged cable could result in an unsafe riding condition.

2-14 PERIODIC MAINTENANCE

Periodic Maintenance Procedures

- Check the idle speed, using the engine revolution tester [A] for high accuracy.
- ★ If the idle speed is out of specified range, adjust it.

Idle Speed:

Standard: 1 800 ±50 r/min (rpm)



Idle Speed Adjustment

- First, turn in the air screw using the pilot screw adjuster [A], until it seats lightly, and back it out the specified number of turns. (see Specifications Section in the Fuel System chapter)

Special Tools - Pilot Screw Adjuster, C: 57001-1292
(or Pilot Screw Adjuster, D: 57001-1588)
Pilot Screw Adjuster Adapter, ϕ 4: 57001-1371

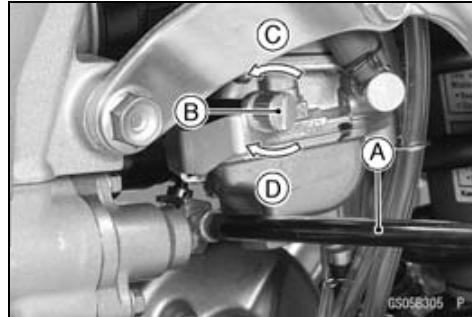

- Start the engine and warm it up thoroughly.
- Turn the idle adjusting screw [B] until the idle speed is correct.
 - To increase idle speed [C]
 - To decrease idle speed [D]
- Open and close the throttle a few times to make sure that the idle speed is within the specified range. Readjust if necessary.

Air Cleaner Element Cleaning and Inspection

NOTE

- In dusty areas, the element should be cleaned more frequently than recommended interval.
- After riding through rain or on muddy roads, the element should be cleaned immediately.
- Since repeated cleaning opens the pores of the element, replace it with a new one in accordance with the Periodic Maintenance Chart. Also, if there is a break in the element material or any other damage to the element, replace the element with a new one.

⚠ WARNING

Clean the element in a well-ventilated area, and take care that there are no sparks or flame anywhere near the working area; this includes any appliance with a pilot light. Because of the danger of highly flammable liquids, do not use gasoline or a low flash-point solvent to clean the element.

Periodic Maintenance Procedures

- Remove:
 - Seat (see Seat Removal in the Frame chapter)
 - Wing Bolt [A]
 - Air Cleaner Element [B]
- Stuff a clean, lint-free towel into the carburetor so no dirt is allowed to enter the carburetor.
- Wipe out the inside of the air cleaner housing with a clean damp towel.

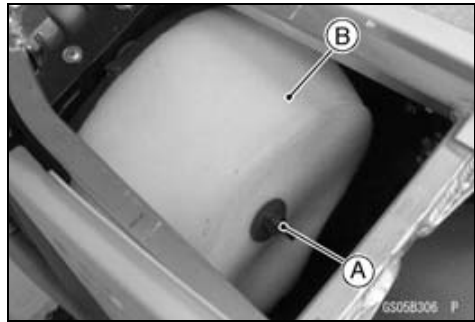

CAUTION

Check inside of the inlet tract and carburetor for dirt. If dirt is present, clean the intake tract and carburetor thoroughly. You may also need to replace the element and seal the housing and inlet tract.

- Separate the element [A] from the frame [B].
- Clean the element [A] in a bath of a high-flash point solvent using a soft bristle brush.

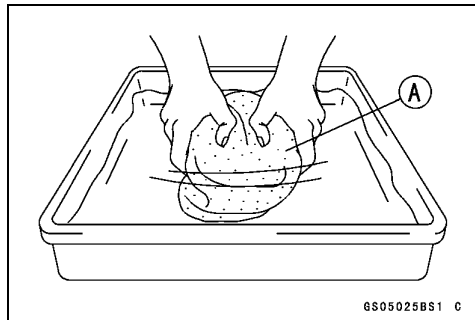
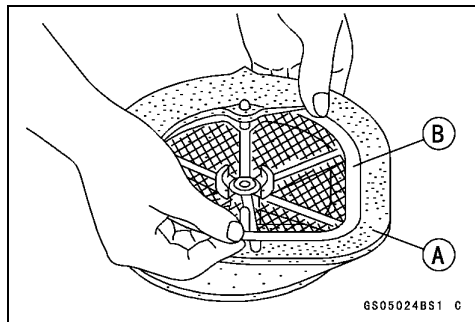

- Squeeze it dry in a clean towel [A]. Do not wring the element or blow it dry; the element can be damaged.
- Check all the parts of the element for visible damage.
- ★ If any of the parts of the element are damaged, replace them.

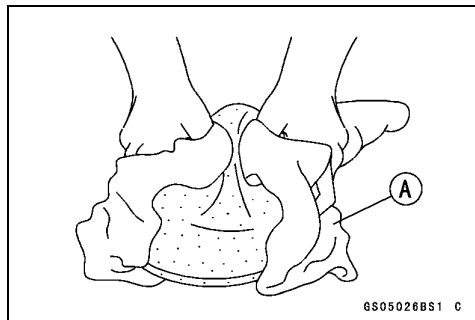

- After cleaning, saturate the element with a high-quality foam-air-filter oil, squeeze out the excess, then wrap it in a clean towel and squeeze it as dry as possible.
- Be careful not to tear the sponge filter.
- Assemble the element.
- Remove the towel from the carburetor.

2-16 PERIODIC MAINTENANCE

Periodic Maintenance Procedures

- Apply grease to all connections and screw holes in the air cleaner housing and intake tract.
- Install the element onto its frame, and coat the element lip and lip seat with a thick layer of all-purpose grease to assure a complete seal.

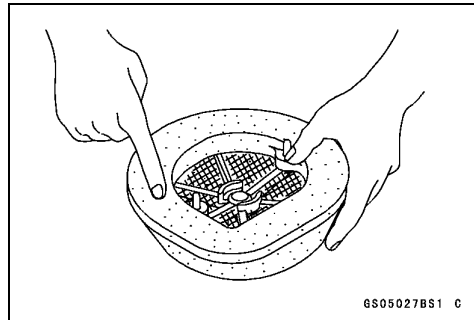

- Install the air cleaner element so that its tab faces [A] upward and its projections [B] align with the holes [C] in the housing.
- Tighten the wing bolt [D]
- Install the seat (see Seat Installation in the Frame chapter).

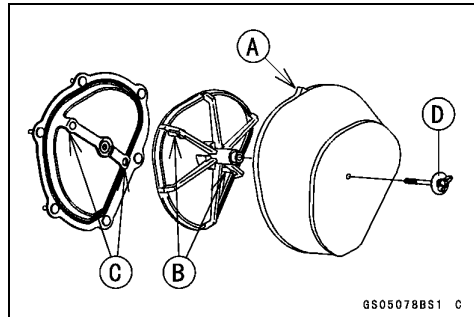

Fuel System Cleaning

⚠ WARNING

Gasoline is extremely flammable and can be explosive under certain conditions. Always stop the engine and do not smoke. Make sure the area is well-ventilated and free from any source of flame or sparks; this includes any appliance with a pilot light.

- Turn the fuel tap to the OFF position.
- Remove the carburetor (see Carburetor Removal in the Fuel System chapter).
- Place a suitable container beneath the carburetor.
- Remove the drain plug [A] from the bottom of the float bowl and check for water or dirt in the fuel.
- ★ If any water or dirt comes out, clean the carburetor, fuel filter, fuel tap and fuel tank.
- Install the drain plug on the float bowl, and tighten it securely.
- Install the carburetor (see Carburetor Installation in the Fuel System chapter).

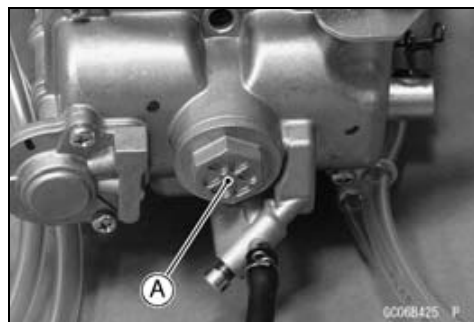

Periodic Maintenance Procedures

Fuel Tank, Filter and Tap Cleaning

⚠ WARNING

Clean the fuel tank in a well-ventilated area, and take care that there is no sparks or flame anywhere near the working area. Because of the danger of highly flammable liquids, do not use gasoline or low flash-point solvent to clean the tank.

- Remove the fuel tank and drain it (see Fuel Tank Removal in the Fuel System chapter).
- Pour some high-flash point solvent into the fuel tank and shake the tank to remove dirt and fuel deposits.
- Drain the solvent out of the tank.
- Remove the fuel filter from the tank by taking out the bolts.
- Clean the fuel filter screen in a high-flash point solvent. After cleaning, install the fuel filter.
- Pour high-flash point solvent through the tap in all lever positions.
- Dry the tank, filter and tap with compressed air.
- Install the filter in the fuel tank.
- Install the tap and fuel tank.

Fuel Tap and Filter Inspection

- Remove the fuel filter from the fuel tank.
- Check the fuel filter screen [A] for any breaks or deterioration.
- ★ If the fuel filter screen have any breaks or is deteriorated, it may allow dirt to reach the carburetor, causing poor running. Replace the fuel filter.
- Remove the fuel tap.
- Check the fuel tap for fuel leaks.
- If the fuel tap leaks, or allows fuel to flow when it is at OFF position, replace the fuel tap.

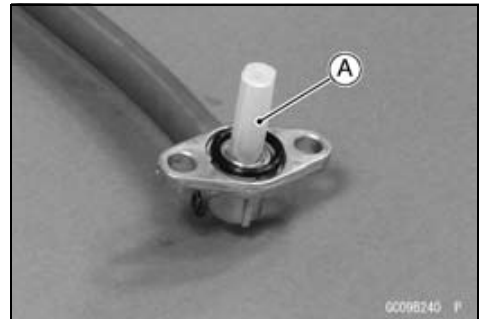

Cooling System

⚠ WARNING

To avoid burns, do not remove the radiator cap or try to change the coolant when the engine is still hot. Wait until it cools down.

Coolant on tires will make them slippery and can cause an accident and injury. Immediately wash away any coolant that spills on the wheels.

Since coolant is harmful to the human body, do not use for drinking.

2-18 PERIODIC MAINTENANCE

Periodic Maintenance Procedures

Coolant Level Inspection

NOTE

○ Check the level when the engine is cold (room or ambient temperature).

- Lean the motorcycle slightly to the left until the radiator cap is level to the ground so that the radiator cap is located uppermost in order to exhaust the air accumulated in the radiator.
- Remove the radiator cap [A].



NOTE

○ Remove the radiator cap in two steps. First turn the cap counterclockwise to the first stop and wait there for a few seconds. Then push down and turn it further in the same direction and remove the cap.

- Check the coolant level. The coolant level [A] should be at the bottom of the filler neck [B].
- ★ If the coolant level is low, add coolant through the filler opening to the bottom of the filler neck. Install the cap.

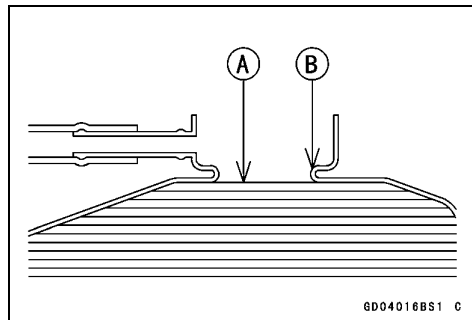

Recommended coolant:

Permanent type of antifreeze (soft water and ethylene glycol plus corrosion and rust inhibitor chemicals for aluminum engines and radiators)

Water and coolant mixture ratio:

1 : 1 (water 50%, Coolant 50%)

Total amount:

1.05 L (1.11 US qt.)

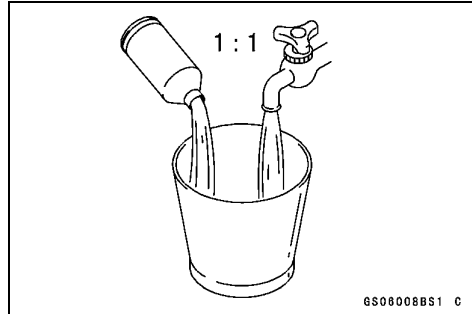

CAUTION

For refilling, add the specified mixture of coolant and soft water. Adding water alone dilutes the coolant and degrades its anticorrosion properties. The diluted coolant can attack the aluminum engine parts. In an emergency, soft water alone can be added. But the diluted coolant must be returned to the correct mixture ratio within a few days.

If coolant must be added often or the reserve tank has run completely dry, there is probably leakage in the cooling system. Check the system for leaks. Coolant ruins painted surfaces. Immediately wash away any coolant that spills on the frame, engine, wheels or other painted parts.

Periodic Maintenance Procedures

Coolant Deterioration Inspection

- Visually inspect the coolant.
- ★ If whitish cotton-like wafts are observed, aluminum parts in the cooling system are corroded. If the coolant is brown, iron or steel parts are rusting. In either case, flush the cooling system.
- ★ If the coolant gives off an abnormal smell, check for a cooling system leak. It may be caused by exhaust gas leaking into the cooling system.

Water Hoses and Connections Inspection

- The high pressure inside the water hose [A] can cause coolant to leak [B] or the hose to burst if the line is not properly maintained. Visually inspect the hoses for signs of deterioration. Squeeze the hoses. A hose should not be hard and brittle, nor should it be soft or swollen.
- ★ Replace the hose if any fraying, cracks [C] or bulges [D] are noticed.
- Check that the hoses are securely connected and clamps are tightened correctly.

Torque - Water Hose Clamp Screws: 1.5 N·m (0.15 kgf·m, 13 in·lb)

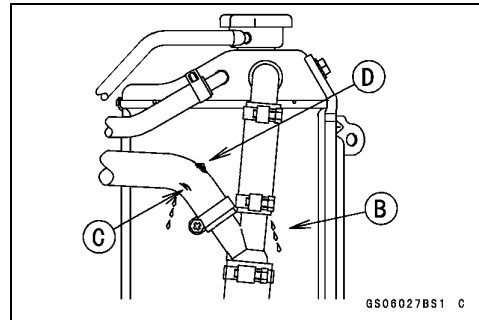

Engine Top End

Valve Clearance Inspection

NOTE

○ Valve clearance must be checked and adjusted when the engine is cold (at room temperature).

- Remove:
 - Cylinder Head Cover (see Cylinder Head Cover Removal in the Engine Top End chapter)
 - Balancer Shaft Plug [A]
 - Timing Inspection Plug [B]

Special Tool - Filler Cap Driver: 57001-1454

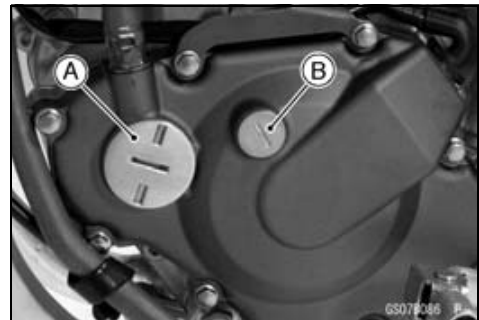

2-20 PERIODIC MAINTENANCE

Periodic Maintenance Procedures

- First, bring the piston to the top-dead-center of its compression stroke to inspect the valve clearance (the position at the end of the compression stroke), when the cam lobe faces outside of the camshaft.
- Place a wrench over the balancer weight nut and turn it counterclockwise to align the TDC mark [A] with the center of the groove [B] of the inspection hole.

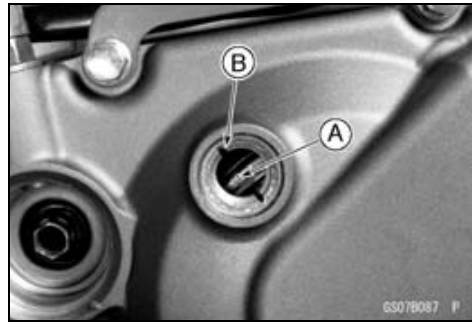

- Using a thickness gauge [A], measure the clearance between each cam lobe and valve lifter for all four valves.
- For the purpose of adjusting the valve clearances, record the measured values.

Valve clearance: between cam and valve lifter

Standard:

Exhaust 0.17 ~ 0.22 mm (0.0067 ~ 0.0087 in.)

Inlet 0.10 ~ 0.15 mm (0.0039 ~ 0.0059 in.)

- ★ If the valve clearance is not within the specified range, adjust it.



Valve Clearance Adjustment

- Remove the camshaft caps [A] (see Camshaft Removal in the Engine Top End chapter).
- Remove the camshafts [B] (see Camshaft Removal in the Engine Top End chapter).
- Remove the valve lifters [C] of the applicable valve.
- Remove the shim [D] from the top of the spring retainer.

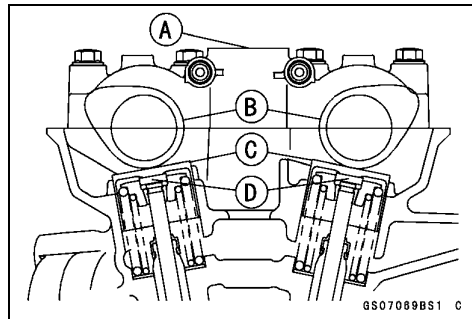

NOTE

- Mark and record the locations of the valve lifters and shims so that they can be reinstalled in their original positions.

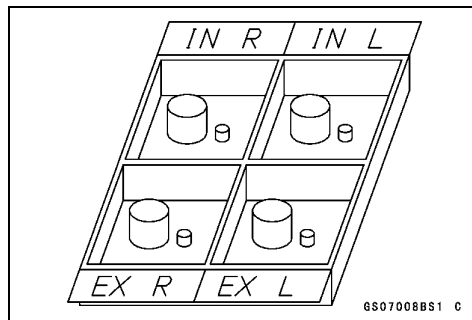

Periodic Maintenance Procedures

- Clean the shim to remove any dust or oil.
- Measure the thickness of the removed shim [A].
- Select a new shim thickness calculation as follows.
 - A = (B – C) + D
 - [A] Replace Shim Thickness
 - [B] Measured Valve Clearance
 - [C] Specified Valve Clearance
 - [D] Present Shim Thickness

Example

$$(0.31 \text{ mm} - 0.10 \sim 0.15 \text{ mm}) + 2.60 \text{ mm} = 2.81 \sim 2.76 \text{ mm}$$

○Exchange the shims for the 2.775 or 2.800 size shim.



CAUTION

Don't use the shims for another models. This could cause wear of the valve stem end, and valve stem damage.

Adjustment shims

Thick-ness	P/No.	Mark	Thick-ness	P/No.	Mark
2.00	92025-1870	0	2.525	92025-1984	53
2.05	92025-1871	5	2.55	92025-1881	55
2.10	92025-1872	10	2.575	92025-1985	58
2.15	92025-1873	15	2.60	92025-1882	60
2.20	92025-1874	20	2.65	92025-1883	65
2.25	92025-1875	25	2.70	92025-1884	70
2.30	92025-1876	30	2.75	92025-1885	75
2.35	92025-1877	35	2.80	92025-1886	80
2.40	92025-1878	40	2.85	92025-1887	85
2.425	92025-1982	43	2.90	92025-1888	90
2.45	92025-1879	45	2.95	92025-1889	95
2.475	92025-1983	48	3.00	92025-1890	00
2.50	92025-1880	50			

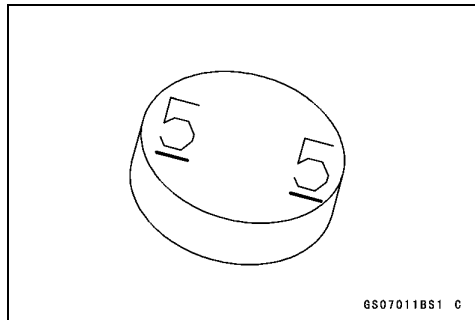

CAUTION

Be sure to remeasure the clearance after selecting a shim. The clearance can be out of the specified range because of the shim tolerance.

○If there is no valve clearance, use a shim that is a few sizes smaller, and remeasure the valve clearance.

2-22 PERIODIC MAINTENANCE

Periodic Maintenance Procedures

- When installing the shim, face the marked side [A] toward the valve lifter [B]. At this time, apply engine oil to the shim or the valve lifter to keep the shim in place during camshaft installation.

CAUTION

Do not put shim stock under the shim. This may cause the shim to pop out at high rpm, causing extensive engine damage.
Do not grind the shim. This may cause it to fracture, causing extensive engine damage.

- Apply engine oil to the valve lifter surface and install the lifter.
- Install the camshaft (see Camshaft Installation in the Engine Top End chapter).
- Recheck the valve clearance and readjust if necessary.
- Install the cylinder head cover (see Engine Top End chapter), timing inspection plug, and the balancer weight plug.

Cylinder Head Warp Inspection

- Remove the cylinder head (see Cylinder Head Removal in the Engine Top End chapter).
- Lay a straightedge [A] across the lower surface of the head at several different points, and measure warp by inserting a thickness gauge between the straightedge and the head.
- ★ If warp exceeds the service limit, repair the mating surface. Replace the cylinder head if the mating surface is badly damaged.

Cylinder Head Warp

Service Limit: 0.05 mm (0.002 in.)

- Remove the valves (see Valve Removal in the Engine Top End chapter).
- Scrape the carbon out of the combustion chamber and exhaust port with a scraper [A] or a suitable tool.
- Clean the cylinder head, using high-flash point solvent.
- Blow out any particles which may obstruct the oil passage in the cylinder head using compressed air.
- Install the valves (see Valve Installation in the Engine Top End chapter).

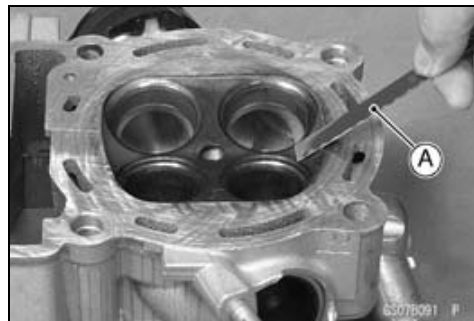
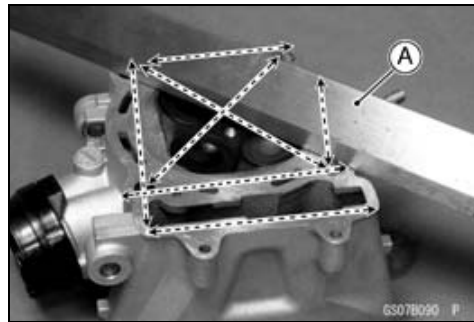

Periodic Maintenance Procedures

Cylinder Wear Inspection

NOTE

○ Measure the cylinder inside diameter when the cylinder is cold (room or ambient temperature).

- Visually Inspect the inside of the cylinder for scratches and abnormal wear.
- ★ If the cylinder is damaged or badly worn, replace it with a new one.
- Since there is a difference in cylinder wear in different directions, take a side-to-side and a front-to-back measurement shown in the figure.
- ★ If any of the cylinder inside diameter measurements exceeds the service limit, the cylinder must be replaced with a new one since the PLATING cylinder cannot be bored or honed.

[A] 10 mm (0.39 in.)

[B] 30 mm (1.2 in.)

[C] 50 mm (2.0 in.)

Cylinder Inside Diameter

Standard: 96.000 ~ 96.012 mm (3.7795 ~ 3.7800 in.), and less than 0.01 mm (0.0004 in.) difference between any two measurements.

Service Limit: 96.10 mm (3.783 in.), or more than 0.05 mm (0.020 in.) difference between any two measurements.

Piston/Cylinder Clearance Inspection

The piston-to-cylinder clearance is measured whenever a piston or cylinder is replaced with a new one. The standard piston-to-cylinder clearance must be adhered to whenever the cylinder is replaced.

If only a piston is replaced, the clearance may exceed the standard slightly. But it must not be less than the minimum, in order to avoid piston seizure.

The most accurate way to find the piston clearance is by making separate piston and cylinder diameter measurements and then computing the difference between the two values. Measure the piston diameter as just described, and measure the cylinder diameter at the very bottom of the cylinder.

Piston/Cylinder Clearance

Standard: 0.020 ~ 0.042 mm (0.00079 ~ 0.0016 in.)

Piston, Piston Ring and Piston Pin Replacement

- Refer to the Cylinder and Piston Section in Engine Top End chapter.

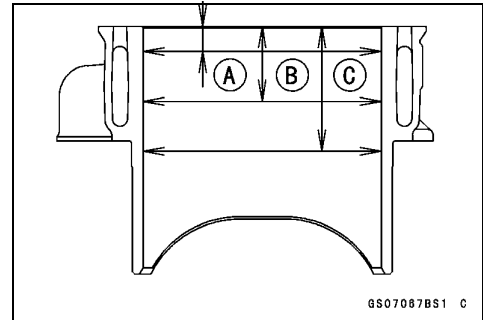

2-24 PERIODIC MAINTENANCE

Periodic Maintenance Procedures

Exhaust System Inspection

- The exhaust system, in particular the muffler body, is designed to reduce exhaust noise and conduct the exhaust gases away from the rider while minimizing power loss. If carbon has built up inside the muffler body, exhaust efficiency is reduced, causing engine performance to drop.
- ★ If the muffler body is badly damaged, dented, cracked or rusted, replace it. Replace the muffler baffle if the exhaust noise becomes too loud or engine performance drops.

Muffler Baffle Change

- Remove the muffler (see Muffler Removal in the Engine Top End chapter).
- Remove the muffler pipe mounting bolts [A].

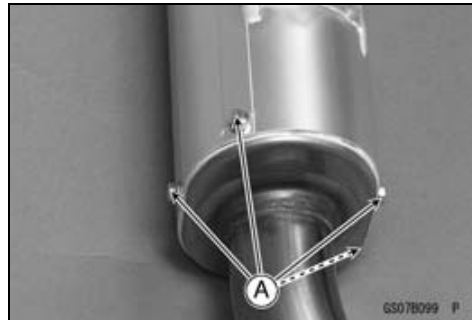

- Tap the bracket [A] of the muffler body with a plastic mallet [B] to separate from the inner pipe.

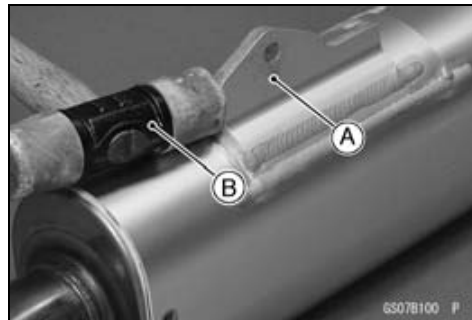

- Pull off the old muffler baffle assembly [A].



- Install the new muffler baffle assembly [A] into the muffler body [B].

NOTE

○ When replacing the muffler baffle assembly, first insert the muffler baffle assembly into the muffler body, and align the exhaust hole of the muffler body with the muffler baffle assembly hole while turning the muffler baffle assembly. Then, install the inner pipe by pushing the inner pipe into the muffler body with aligning the inner pipe with the exhaust hole.

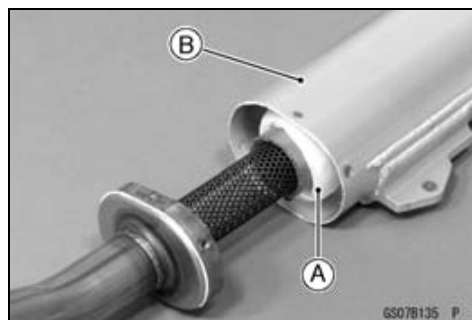

- Apply a non-permanent locking agent to the muffler pipe mounting bolts.
- Tighten the muffler pipe mounting bolts.

Periodic Maintenance Procedures

- Apply silicone sealant to the circumference [A] of the inner pipe.
- Install the muffler (see Muffler Installation in the Engine Top End chapter).

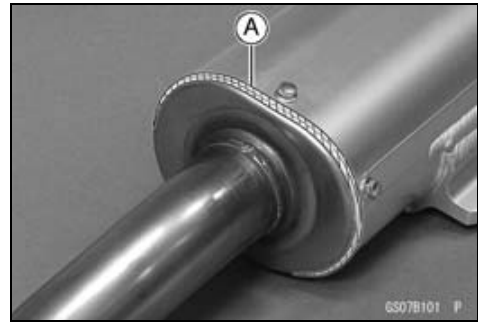

Engine Right Side

⚠ WARNING

To avoid a serious burn, never touch the hot engine or exhaust chamber during clutch adjustment.

Clutch Lever (Clutch Cable) Free Play Inspection

- Slide the clutch lever dust covers [A] out of place.
 - Check that the clutch cable upper end is fully seated in the adjusting bolt [B].
 - Check that the clutch lever [C] has 8 ~ 13 mm (0.3 ~ 0.5 in.) of play [D].
- ★ If it does not, adjust the lever play.

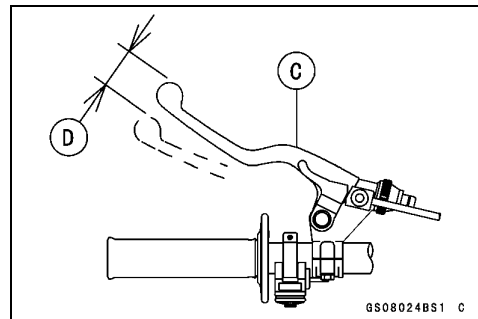
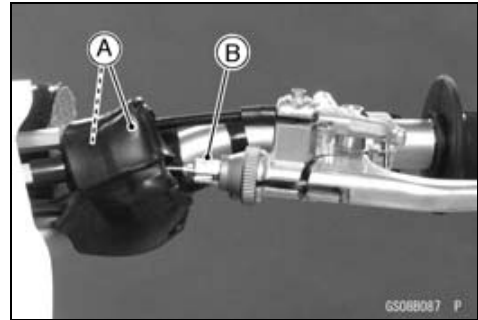

Clutch Lever (Clutch Cable) Free Play Adjustment

- Slide the clutch lever dust cover out of place.
- Turn the adjuster [A] so that the clutch lever will have 8 ~ 13 mm (0.3 ~ 0.5 in.) of play.

NOTE

○ Be sure that the outer cable end at the clutch lever is fully seated in the adjusting bolt at the clutch lever, or it could slip into the place later, creating enough cable play to prevent clutch disengagement.



2-26 PERIODIC MAINTENANCE

Periodic Maintenance Procedures

- If it cannot be done, loosen the locknut [A] at the middle of the clutch cable, and turn the adjusting nut [B] so that the clutch lever has 8 ~ 13 mm (0.3 ~ 0.5 in.) of play.
- After the adjustment is made, tighten the locknut, and start the engine and check that the clutch does not slip and that it release properly.

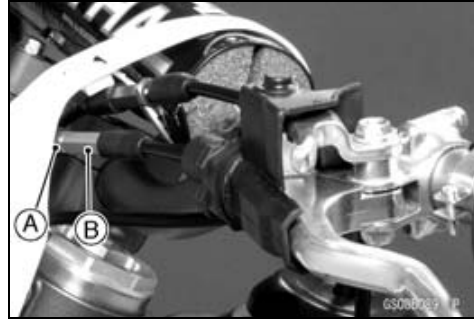

Clutch Plates Inspection

- Remove the clutch plates (see Clutch Removal in the Engine Right Side chapter).
- Visually inspect the friction and steel plates to see if they show any signs of seizure, or uneven wear.
- ★ If any plates show signs of damage, replace the friction plates and steel plates as a set.
- Measure the thickness [A] of the friction plates with vernier calipers.
- ★ If they have worn past the service limit, replace them with new ones.

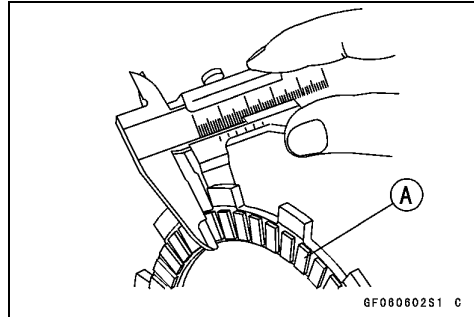

Friction Plate Thickness

- Standard:** 2.92 ~ 3.08 mm (0.115 ~ 0.121 in.)
Service Limit: 2.6 mm (0.10 in.)

- Place each friction plate or steel plate on a surface plate, and measure the gap between the surface plate [A] and each friction plate or steel plate [B] with a thickness gauge [C]. The gap is the amount of friction or steel plate warp.
- ★ If any plate is warped over the service limit, replace it with a new one.

Friction and Steel Plates Warp

- Standard:**
- | | |
|-----------------------|---|
| Friction Plate | Not more than 0.15 mm (0.0059 in.) |
| Steel Plate | Not more than 0.2 mm (0.008 in.) |
- Service Limit:**
- | | |
|-----------------------|--------------------------|
| Friction Plate | 0.3 mm (0.01 in.) |
| Steel Plate | 0.3 mm (0.01 in.) |

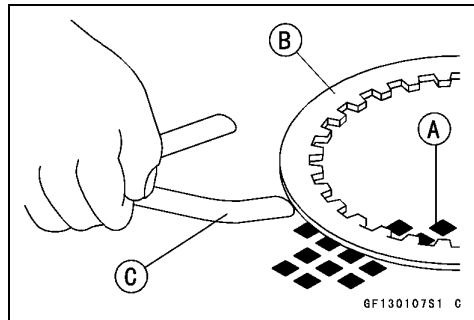

Engine Lubrication System

Engine Oil Change

- Warm up the engine thoroughly so that the oil will pick up any sediment and drain easily. Then stop the engine.

Periodic Maintenance Procedures

- Remove the engine oil drain plugs on the bottom of the engine, and let the oil drain completely.
 Drain Plug (for transmission room oil sump) [A]
 Drain Plug (for crank oil sump) [B]

NOTE

○ Hold the motorcycle upright so that the oil may drain completely.

- Replace the gaskets at the drain plugs with a new one.
- After the oil has completely drained out, install the drain plugs with the gaskets, and tighten them.

Torque - Engine Oil Drain Bolts

Transmission Room Oil Sump: 20 N·m (2.0 kgf·m, 15 ft·lb)

Crank Room Oil Sump: 7.0 N·m (0.71 kgf·m, 62 in·lb)

- Fill the engine with a good quality motor oil specified below.

Recommended Engine

- Type** Castrol "R4 Superbike" 5W-40 (KX450D6F ~ D7F),
 Castrol "POWER1 R4 Racing" 5W-40 (KX450D8F) or
 API SG, SH, SJ or SL with JASO MA
- Viscosity** SAE 10W-30, 10W-40, 10W-50
- Capacity** 0.96 L (1.01 US qt.) (when filter is not removed)
 0.98 L (1.03 US qt.) (when filter is removed)
 1.2 L (1.3 US qt.) (when engine is completely dry)

NOTE

○ The oil viscosity may need to be changed to accommodate atmospheric conditions in your riding area.

- Check the oil level (see Engine Oil Level Inspection in the Engine Lubrication System chapter).

Oil Filter Change

- Drain:
 Engine Oil (see Engine Oil Change)
- Remove:
 Oil Filter Cover Bolts [A]
 Oil Filter Cover [B]

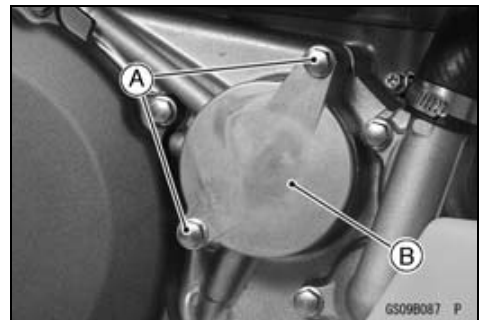
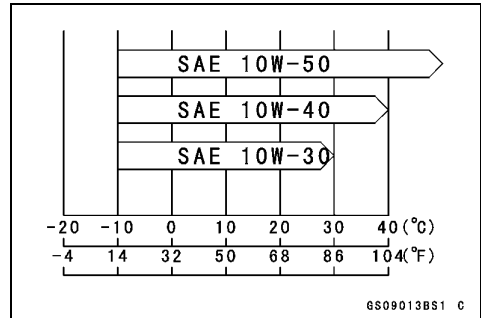
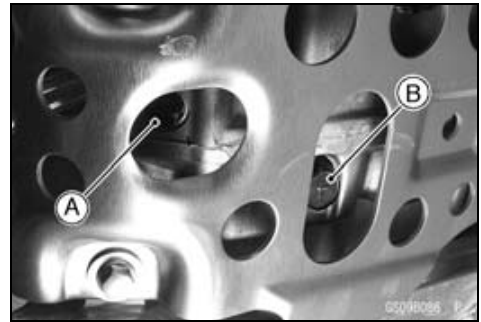

2-28 PERIODIC MAINTENANCE

Periodic Maintenance Procedures

- Remove the Oil Filter [A].

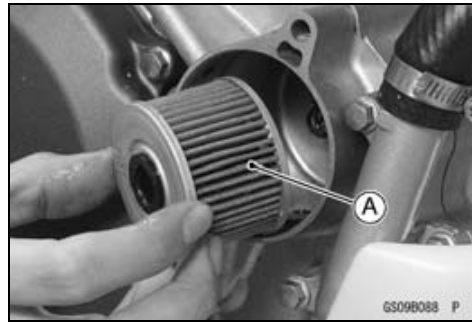

- Install the spring [A] to the right engine cover.
- Apply grease to the grommet [B].
- Be sure to install the filter with the grommet facing outside as shown.

CAUTION

Inside out installation stop oil flow, causing engine seizure.



- Replace the oil filter cover O-ring [A] with a new one.
- Replace the oil filter with a new one.
- Apply grease to the O-rings.
- Install the oil filter cover.

Torque - Oil Filter Cover Bolt: 9.8 N·m (1.0 kgf·m, 87 in·lb)

- Pour in the specified type and amount of oil (see Engine Oil Change).



Breather Hose Inspection

- Be certain that the breather hose are routed without being flattened or kinked and is connected correctly.
- ★ If it is not, correct it.
- Inspect the breather hose [A] for damage or signs of deterioration.
- This hose should not be hard and brittle, nor should be soft swollen.
- ★ Replace it if any cracks or swelling is noticed.



Periodic Maintenance Procedures

Crankshaft/Transmission

Crankshaft Inspection

Connecting Rod Big End Side Clearance

- Remove the cylinder head (see Cylinder Head Removal in the Engine Top End chapter).
- Remove the cylinder (see Cylinder Removal in the Engine Top End chapter).
- Remove the piston (see Piston Removal in the Engine Top End chapter).
- Measure the connecting rod big end side clearance at right side of big end using a thickness gauge [A].

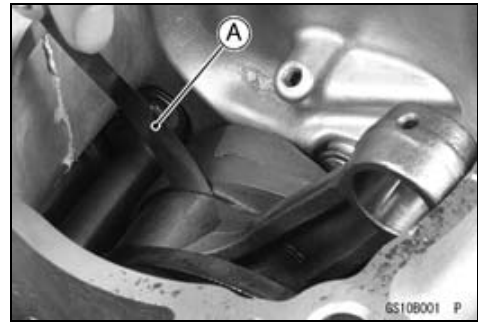

Connecting Rod Big End Side Clearance

Standard: 0.25 ~ 0.35 mm (0.0098 ~ 0.014 in.)

Service Limit: 0.6 mm (0.02 in.)

- ★ If the clearance exceeds the service limit, replace the crankshaft assembly.
- Make sure that the crankshaft rotates smoothly after assembling the engine.

Wheel/Tires

Air Pressure Inspection/Adjustment

- Using tire air pressure gauge [A], measure the tire pressure when the tires are cold.
- ★ Adjust the tire air pressure to suit track conditions and rider preference, but do not stray too far from the recommended pressure.

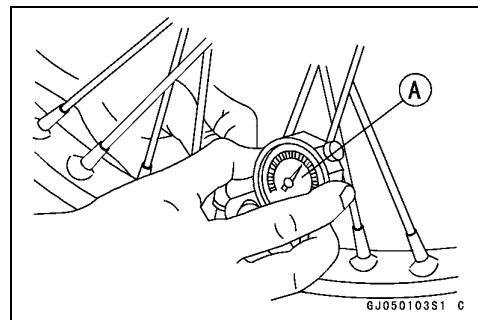

Track Condition	Tire Pressure
When the track is wet, muddy, sandy or slippery, reduce the tire pressure to increase the tire tread surface on the ground.	80 kPa (0.8 kgf/cm ² , 11 psi) ↑
When the track is pebbly or hard, increase the tire pressure to prevent damage or punctures, through the tires will skid more easily.	↓ 100 kPa (1.0 kgf/cm ² , 14 psi)

2-30 PERIODIC MAINTENANCE

Periodic Maintenance Procedures

Tires Inspection

As the tire tread wears down, the tire becomes more susceptible to puncture and failure.

- Remove any imbedded stones or other foreign particles from the tread.
- Visually inspect the tire for cracks and cuts, replacing the tire in case of bad damage. Swelling or high spots indicate internal damage, requiring tire replacement.

⚠ WARNING

To ensure safe handling and stability, use only the recommended standard tires for replacement, inflated to the standard pressure.

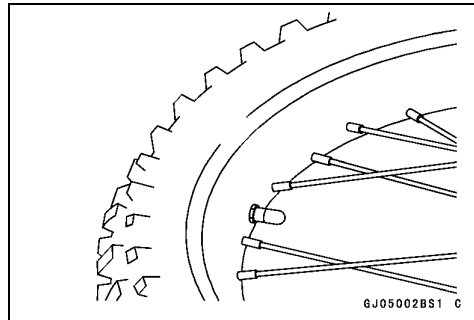

NOTE

- Check and balance the wheel when a tire is replaced with a new one.

Standard Tire

Front:

Size: 90/100-21 57M

Make: DUNLOP

Type: D742F, Tube

Rear:

Size: 120/80-19 63M

Make: DUNLOP

Type: D756, Tube

Spoke Tightness Inspection

- Check that all the spokes are tightened evenly.
- ★ If spoke tightness is uneven or loose, tighten the spoke nipples evenly.

Torque - Spoke Nipples: 2.2 N·m (0.22 kgf·m, 19 in·lb)

- Check the rim runout.

⚠ WARNING

If any spoke breaks, it should be replaced immediately. A missing spoke places an additional load on the other spokes, which will eventually cause other spokes to break.

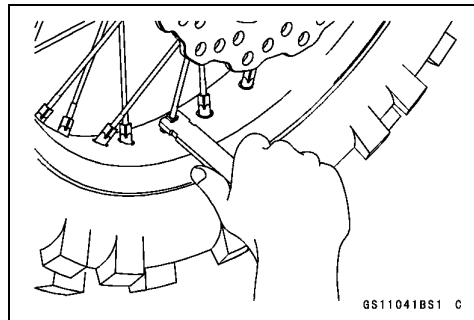

Periodic Maintenance Procedures

Rim Runout Inspection

- Place the jack under the frame so that the front/rear wheel off the ground.

Special Tool - Jack: 57001-1238

- Inspect the rim for small cracks, dents, bending, or warping.
- ★ If there is any damage to the rim, it must be replaced.
- Set a dial gauge against the side of the rim, and rotate the rim to measure the axial runout [A]. The difference between the highest and lowest dial readings is the amount of runout.
- Set a dial gauge against the outer circumference of the rim, and rotate the rim to measure radial runout [B]. The difference between the highest and lowest dial readings is the amount of runout.
- ★ If rim runout exceeds the service limit, check the wheel bearings first. Replace them if they are damaged. If the problem is not due to the bearings, correct the rim warp (runout). A certain amount of rim warp can be corrected by recentering the rim. Loosen some spokes and tighten others within the standard torque to change the position of different parts of the rim. If the rim is badly bent, however, it must be replaced.

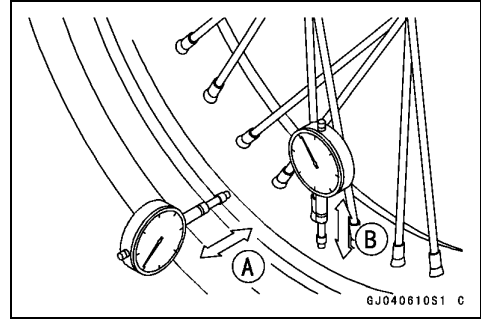

Rim Runout (with tire installed)

Standard:

Axial	TIR 1.0 mm (0.039 in.) or less
Radial	TIR 1.0 mm (0.039 in.) or less

Service Limit:

Axial	TIR 2 mm (0.08 in.)
Radial	TIR 2 mm (0.08 in.)

Wheel Bearing Inspection

- Raise the front/rear wheel off the ground.

Special Tool - Jack: 57001-1238

- Spin the wheel lightly, and check for roughness, binding or noise.
- ★ If roughness, binding, abnormal noise is found, replace the hub bearing.



- Turn the handlebar until the handlebar doesn't move to either side.
- The wheel edge is moved to one direction gripping the edge of the wheel by both hands and the play of the wheel bearing is checked.
- ★ If the play is found, replace the bearing.



2-32 PERIODIC MAINTENANCE

Periodic Maintenance Procedures

Final Drive

Drive Chain Slack Inspection

- Raise the rear wheel off the ground, rotate the rear wheel to find the place where the chain is tightest (because it wears unevenly).
- Check the wheel alignment (see Wheel Alignment Inspection in the Final Drive chapter), and adjust it if necessary (see Drive Chain Slack Adjustment).

NOTE

○ Clean the drive chain if it is dirty, and lubricate it if it appears dry.

- Rotate the rear wheel to find the position where the chain is tightest.
- Measure the space (chain slack) [A] between the chain and the swingarm at the rear of the chain slipper as shown.
- ★ If the drive chain slack exceeds the standard, adjust it.

Chain Slack

Standard: 52 ~ 58 mm (2.0 ~ 2.3 in.)

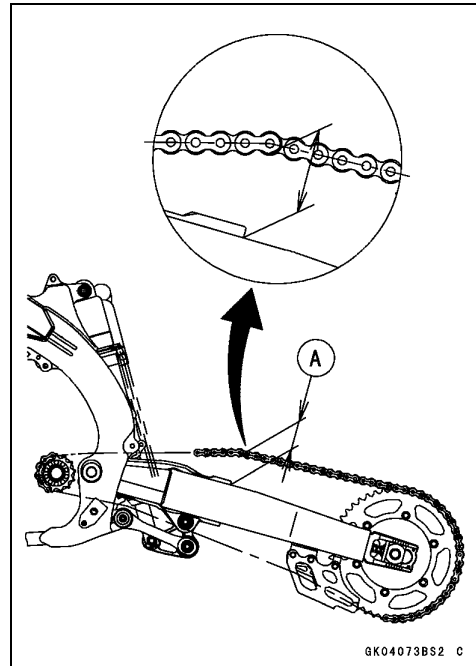

Drive Chain Slack Adjustment

- Loosen the left and right chain adjuster locknuts [A].
- Remove the cotter pin [B] and loosen the axle nut [C].
- ★ If the chain is too tight, back out the left and right chain adjusting bolts [D] evenly, and push the wheel forward until the chain is too loose.
- ★ If the chain is too loose, turn both chain adjusting bolts evenly until the drive chain has the correct amount of slack. To keep the chain and wheel properly aligned, the notch on the left chain adjuster should align with the same swingarm mark [E] as the right chain adjuster notch [F].
- ★ Check the wheel alignment.

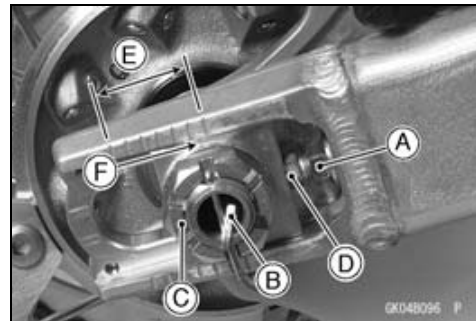

▲ WARNING

Misalignment of the wheel result in abnormal wear and may result in an unsafe riding condition.

- Tighten both chain adjuster locknuts securely.
 - Tighten the axle nut.
- Torque - Rear Axle Nut: 108 N·m (11 kgf·m, 80 ft·lb)**
- Rotate the wheel, measure the chain slack again at the tightest position, and readjust if necessary.
 - Install a new cotter pin [A] through the axle nut and axle, and spread its ends.

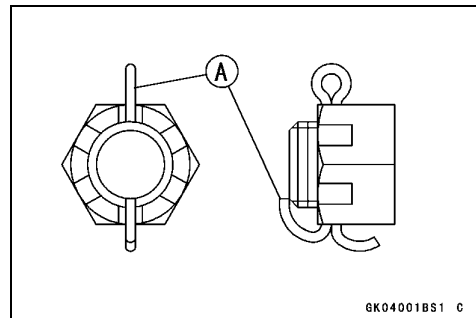

Periodic Maintenance Procedures

NOTE

- When inserting the cotter pin, if the slots in the nut do not align with the cotter pin hole in the axle shaft, tighten the nut clockwise [A] up to next alignment.
- It should be within 30 degree.
- Loosen once and tighten again when the slot goes past the nearest hole.

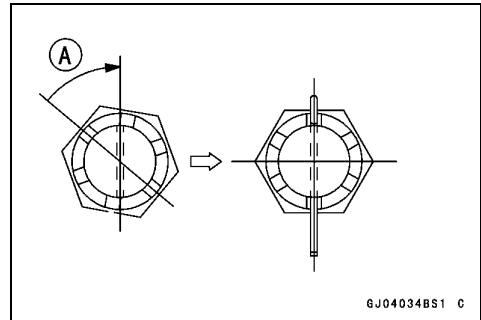

⚠ WARNING

If the axle nut is not securely tightened, or the cotter pin is not installed, an unsafe riding condition may result.

- Check the rear brake.

NOTE

- In wet and muddy conditions, mud sticks to the chain and sprockets resulting in an overly tight chain, and the chain may break. To prevent this, adjust the chain to 58 ~ 68 mm (2.28 ~ 2.68 in.) of slack whenever necessary.

Drive Chain Wear Inspection

- Rotate the rear wheel to inspect the drive chain for damaged rollers, and loose pins and links.
- ★ If there is any irregularity, replace the drive chain.
- ★ Lubricate the drive chain if it appears dry.

- [A] Bushing
- [B] Roller
- [C] Pin
- [D] Pin Link
- [E] Roller Link

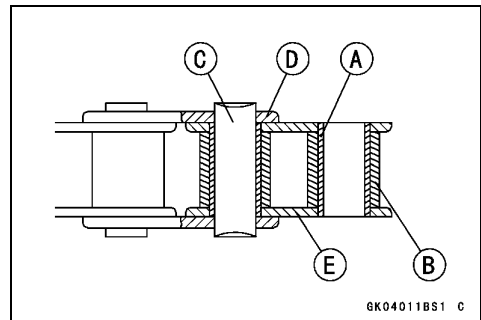

- Stretch the chain taut by hanging a 98 N (10 kgf, 20 lb) weight [A] on the chain.
- Measure the length of 20 links [B] on the straight part [C] of the chain from the pin center of the 1st pin to the pin center of the 21st pin. Since the chain may wear unevenly, take measurements at several places.

Chain 20-link Length

Standard: 317.5 ~ 318.2 mm (12.50 ~ 12.53 in.)

Service Limit: 323 mm (12.7 in.)

- ★ If any measurements exceed the service limit, replace the chain. Also, replace the front and rear sprockets when the drive chain is replaced.

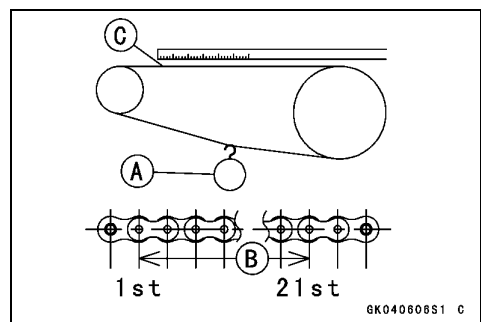

2-34 PERIODIC MAINTENANCE

Periodic Maintenance Procedures

⚠ WARNING

If the drive chain wear exceeds the service limit, replace the chain or an unsafe riding condition may result. A chain that breaks or jumps off the sprockets could snag on the engine sprocket or lock the rear wheel, severely damaging the motorcycle and causing it to go out of control.

Standard Chain

Make: DAIDO

Type: D.I.D 520DMA2

Link: 114 Links

Drive Chain Lubrication

- The chain should be lubricated with a lubricant which will both prevent the exterior from rusting and also absorb shock and reduce friction in the interior of the chain.
- ★ If the chain is especially dirty, it should be washed in diesel oil or kerosene, and afterward soaked in a heavy oil. Shake the chain while it is in the oil so that oil will penetrate to the inside of each roller.
- An effective, good quality lubricant specially formulated for chains is best for regular chain lubrication.
- If a special lubricant is not available, a heavy oil such as SAE90 is preferred to a lighter oil because it will stay on the chain longer and provide better lubrication.
- Apply oil to the sides of the rollers so that oil will penetrate into the rollers and bushings.
- Wipe off any excess oil.
 - Oil applied area [A]

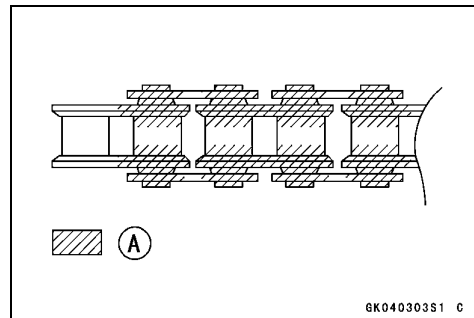

Sprocket Wear Inspection

- Visually inspect the front and rear sprocket teeth for wear and damage.
- ★ If they are worn as illustrated or damaged, replace the sprocket.
 - [A] Worn Tooth (Engine Sprocket)
 - [B] Worn Tooth (Rear Sprocket)
 - [C] Direction of Rotation

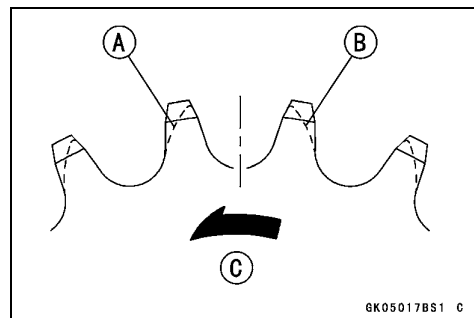

NOTE

○ If a sprocket requires replacement, the chain is probably worn also. When replacing a sprocket, inspect the chain.

Periodic Maintenance Procedures

Rear Sprocket Warp (Runout) Inspection

- Using the jack, raise the rear wheel off the ground.

Special Tool - Jack: 57001-1238

- Set a dial gauge [A] against the rear sprocket [B] near the teeth as shown and rotate [C] the rear wheel to measure the sprocket runout (warp). The difference between the highest and lowest dial gauge readings is the amount of runout (warp).

- ★ If the runout exceeds the service limit, replace the rear sprocket.

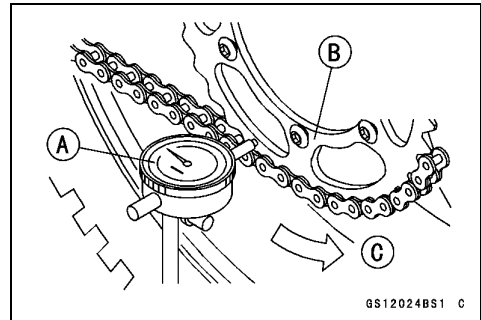

Rear Sprocket Warp (Runout)

Standard: TIR 0.4 mm (0.016 in.) or less

Service Limit: TIR 0.5 mm (0.02 in.)

Brakes

Brake Lever and Pedal Position Adjustment

⚠ WARNING

Always maintain proper brake adjustment. If adjustment is improper, the brake could drag and overheat. This could damage the brake assembly and possibly lock the wheel resulting in loss of control.

- Adjust the front brake lever [A] to suit you.
- Slide the brake lever dust cover [B] out of place.
- Loosen the adjuster locknut [C] and turn the adjuster [D] to either side.
- After adjustment, tighten the locknut.

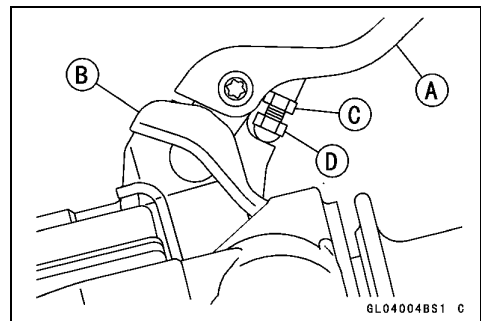

NOTE

○ Usually it is not necessary to adjust the pedal position, but always adjust it when the master cylinder is disassembled or pedal position is incorrect.

- Measure the length indicated in the figure.

Length [A]

Standard: 68.5 ±1 mm (3.09 ±0.04 in.)

- ★ If it is not specified length, the brake pedal may be deformed or incorrectly installed.
- ★ If it is not within the specified length, adjust the push rod in the master cylinder as follows.

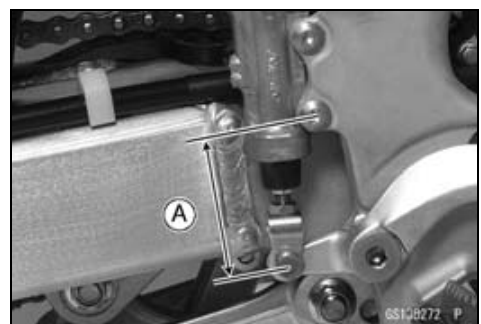

2-36 PERIODIC MAINTENANCE

Periodic Maintenance Procedures

- Loosen the push rod locknut [A].
- Replace the cotter pin with a new one.
- Remove:
 - Cotter Pin [B]
 - Washer
 - Joint Pin [C]
- Turn the U link [D] to obtain the specified length.
- Tighten the locknut.

**Torque - Rear Master Cylinder Push Rod Locknut: 17 N·m
(1.7 kgf·m, 13 ft·lb)**

Brake Fluid Level Inspection

- Check the brake fluid level in the front or rear brake reservoir [A].

NOTE

- Hold the reservoir horizontal when checking brake fluid level.
- The front or rear reservoir must be kept above the lower level line [B].
- If the fluid level in front or rear reservoir is lower than the lower level line, fill the reservoir to the upper level line. Inside the reservoir is stopped end showing the upper level line [C].

Torque - Reservoir Cap Screws: 1.5 N·m (0.15 kgf·m, 13 in·lb)

⚠ WARNING

Do not mix two brands of fluid. Change the brake fluid in the brake line completely if the brake fluid must be refilled but the type and brand of the brake fluid that is already in the reservoir are unidentified. After changing the fluid, use only the same type and brand of fluid thereafter.

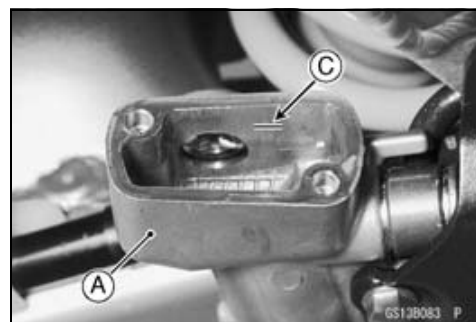
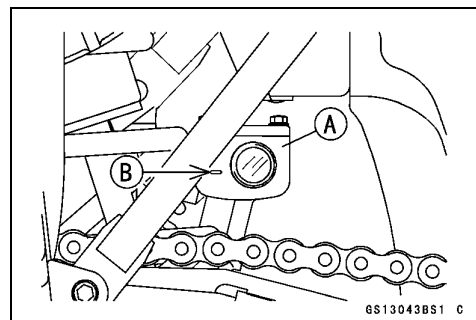
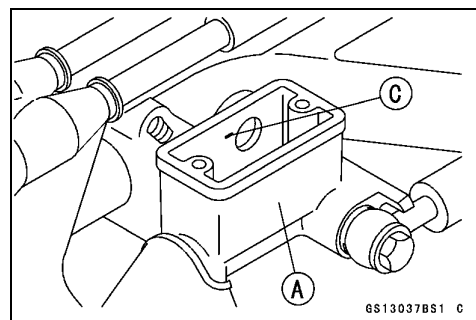
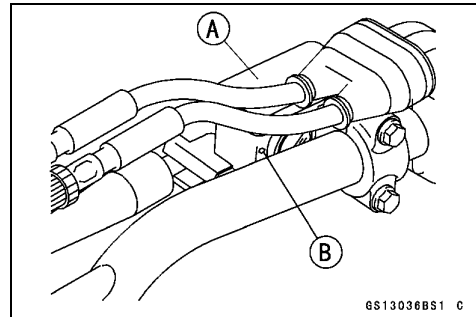
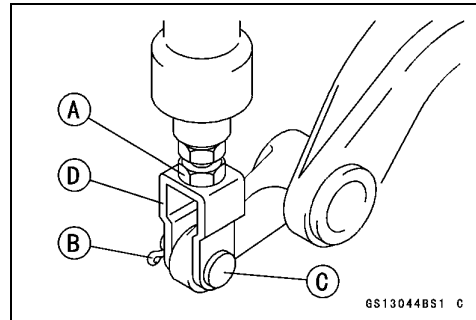

Periodic Maintenance Procedures

Brake Fluid Change

In accordance with the Periodic Maintenance Chart, change the brake fluid. The brake fluid should also be changed if it becomes contaminated with dirt or water. Furthermore, the brake fluid should be changed to bleed the air quickly and completely whenever the brake line parts are removed.

▲ WARNING

When working with the disc brake, observe the precautions listed below.

1. Never reuse old brake fluid.
2. Do not use fluid from a container that has been left unsealed or that has been open for a long time.
3. Do not mix two types and brands of fluid for use in the brake. This lowers the brake fluid boiling point and could cause the brake to be ineffective. It may also cause the rubber brake parts to deteriorate.
4. Don't leave the reservoir cap off for any length of time to avoid moisture contamination of the fluid.
5. Don't change the fluid in the rain or when a strong wind is blowing.
6. Except for the disc pads and disc, use only disc brake fluid, isopropyl alcohol, or ethyl alcohol for cleaning brake parts. Do not use any other fluid for cleaning these parts. Gasoline, engine oil, or any other petroleum distillate will cause deterioration of the rubber parts. Oil spilled on any part will be difficult to wash off completely and will eventually deteriorate the rubber used in the disc brake.
7. When handling the disc pads or disc, be careful that no disc brake fluid or any oil gets on them. Clean off any fluid or oil that inadvertently gets on the pads or disc with a high-flash point solvent. Do not use one which will leave an oily residue. Replace the pads with new ones if they cannot be cleaned satisfactorily.
8. Brake fluid quickly ruins painted surfaces; any spilled fluid should be completely wiped up immediately.
9. If any of the brake line fittings or the bleed valve is opened at any time, the **AIR MUST BE BLED FROM THE BRAKE LINE.**

Recommended Disc Brake Fluid

Type:

Front DOT3 or DOT4

Rear DOT4

2-38 PERIODIC MAINTENANCE

Periodic Maintenance Procedures

NOTE

○The procedure to change the front brake fluid is as follows. Changing the rear brake fluid is the same as for the front brake.

- Level the brake fluid reservoir.
- Remove the screws [A], reservoir cap [B] and diaphragm [C].

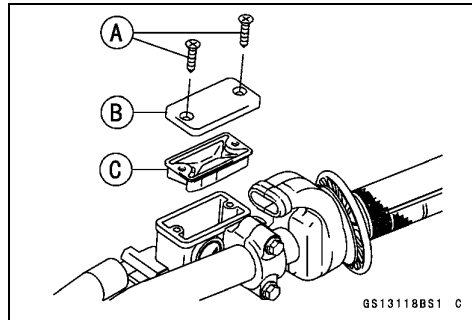

- Remove the rubber cap [A] on the bleed valve [B].

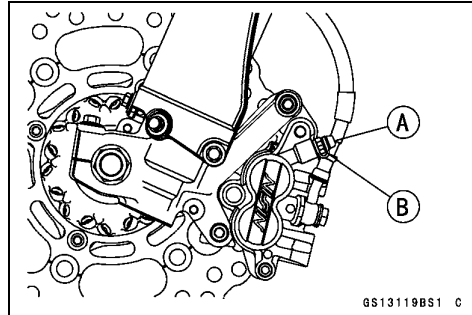

- Attach a clear plastic hose [A] to the bleed valve on the caliper, and run the other end of the hose into a container [B].

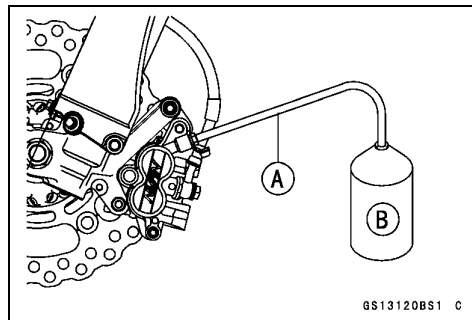

- Change the brake fluid as follows:
 - Repeat this operation until fresh brake fluid comes out from the plastic hose or the color of the fluid changes.
 - 1. Open the bleed valve [A]
 - 2. Apply the brake and hold it [B]
 - 3. Close the bleed valve [C]
 - 4. Release the brake [D]
- Fill the reservoir with fresh specified brake fluid.

NOTE

○The fluid level must be checked often during the changing operation and replenished with fresh brake fluid. If the fluid in the reservoir runs out any time during the changing operation, the brakes will need to be bled since air will have entered the brake line.

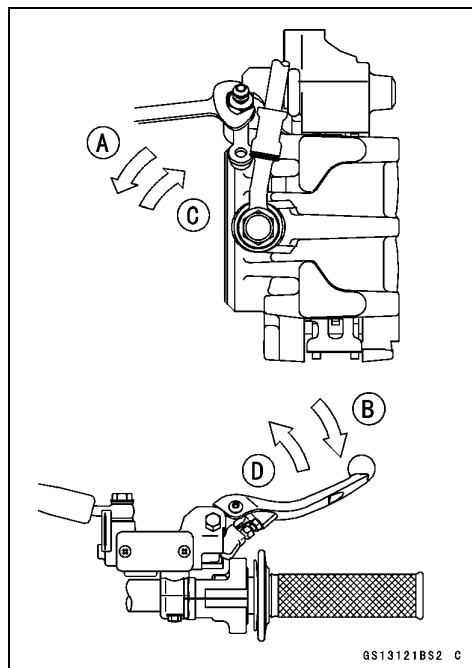

Periodic Maintenance Procedures

- Remove the clear plastic hose.
- Tighten the bleed valves, and install the rubber caps.
Torque - Caliper Bleed Valve: 7.8 N·m (0.80 kgf·m, 69 in·lb)
Brake Reservoir Cap Screws: 1.5 N·m (0.15 kgf·m, 13 in·lb)
- After changing the fluid, check the brake for good braking power, no brake drag, and no fluid leakage.
- ★ If necessary, bleed the air from the lines (see Bleeding the Brake Line in the Brakes chapter).

⚠ WARNING

Do not mix two brands of fluid. Change the brake fluid in the brake line completely if the brake fluid must be refilled but the type and brand of the brake fluid that is already in the reservoir are unidentified.

Brake Pad Wear Inspection

- Remove the brake pad (see Brake Pad Removal in the Brakes chapter).
- Check the lining thickness and condition of the pads in each caliper.
- ★ If either pad is damaged, replace both pads in the caliper as a set.
- ★ If the lining thickness [A] of either pad is less than the service limit [B], replace both pads in the caliper as a set.

Lining Thickness

Standard:

- Front 3.8 mm (0.15 in.)**
- Rear 6.4 mm (0.25 in.)**

Service Limit:

- Front 1 mm (0.04 in.)**
- Rear 1 mm (0.04 in.)**

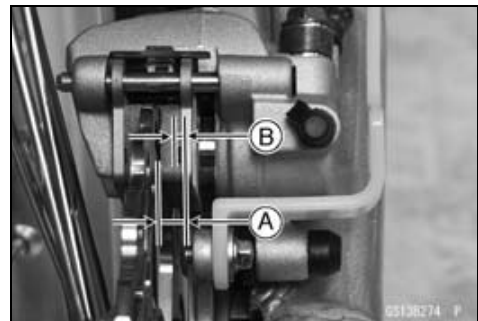
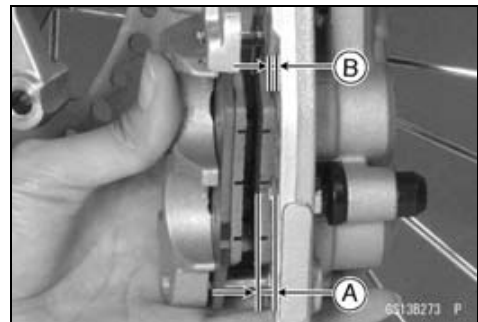

Brake Master Cylinder Cup and Dust Cover Replacement

- Remove the front master cylinder (see Front Master Cylinder Removal in the Brakes chapter).
- Remove the reservoir cap and diaphragm, and pour the brake fluid into a container.
- Unscrew the locknut and pivot bolt, and remove the brake lever.
- Pull the dust cover [A] out of place, and remove the circlip [B].

Special Tool - Inside Circlip Pliers: 57001-143

- Remove the washer [C].
- Pull out the piston [D], secondary cup [E], primary cup [F], and return spring [G].

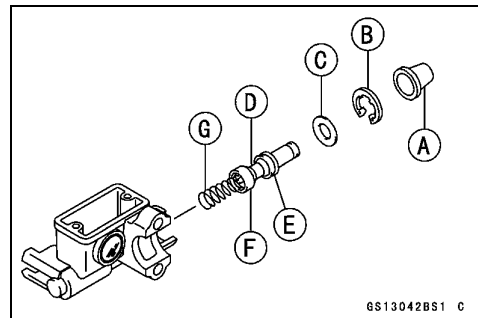

2-40 PERIODIC MAINTENANCE

Periodic Maintenance Procedures

CAUTION

Do not remove the secondary cup from the piston since removal will damage it.

- Remove the rear master cylinder (see Rear Master Cylinder Removal in the Brakes chapter).

NOTE

○ Do not remove the push rod clevis for master cylinder disassembly since removal requires brake pedal position adjustment.

- Remove the reservoir cap and diaphragm, and pour the brake fluid into a container.
- Slide the dust cover [A] on the push rod [B] out of place, and remove the circlip [C].

Special Tool - Inside Circlip Pliers: 57001-143

- Pull out the push rod with the piston stop [D].
- Take off the piston [E], secondary cup [F], primary cup [G], and return spring [H].

CAUTION

Do not remove the secondary cup from the piston since removal will damage it.

- Before assembly, clean all parts including the master cylinder with brake fluid or alcohol.

CAUTION

Except for the disc pads and disc, use only disc brake fluid, isopropyl alcohol, or ethyl alcohol for cleaning of the brake parts. Do not use any other fluid for cleaning of these parts. Gasoline, engine oil, or any other petroleum distillate will cause deterioration of the rubber parts. Oil spilled on any part will be difficult to wash off completely, and will eventually deteriorate the rubber used in the disc brake.

- Apply brake fluid to the removed parts and to the inner wall of the cylinder.
- Take care not to scratch the piston or the inner wall of the cylinder.
- Apply silicone grease (ex. PBC grease).
 - Brake Lever Pivot Bolt
 - Brake Lever Pivot Contact
 - Push Rod Contact (Rear)
 - Dust Covers
- Tighten:
 - Torque - Brake Lever Pivot Bolt: 5.9 N·m (0.60 kgf·m, 52 in·lb)**
 - Brake Lever Pivot Bolt Locknut: 5.9 N·m (0.60 kgf·m, 52 in·lb)**

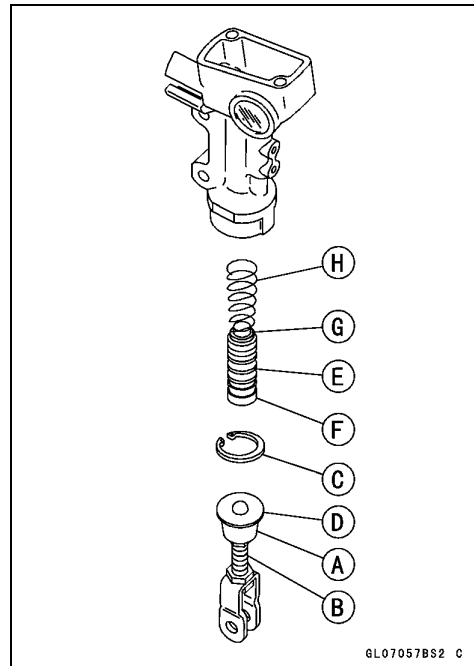

Periodic Maintenance Procedures

Brake Caliper Fluid Seal and Dust Seal Replacement

- Loosen the brake pad pin [A] and banjo bolt [B], and tighten them loosely.
- Remove:
 - Front Caliper Mounting Bolts [C]
 - Banjo Bolt
 - Brake Hose [E]
 - Front Caliper [D] (see Front Caliper Removal in the Brakes chapter)
 - Brake Pads (see Brake Pad Removal in the Brakes chapter)
- Separate the caliper holder [A] from the caliper [B] and remove the anti-rattle spring.

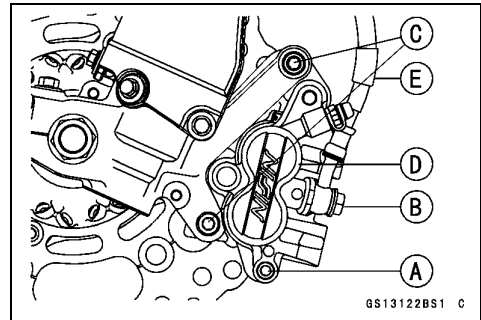

- Using compressed air, remove the pistons. One way to remove the pistons is as follows.
 - Cover the caliper opening with a clean, heavy cloth [A].
 - Remove the pistons by lightly applying compressed air [B] to the hose joint opening.

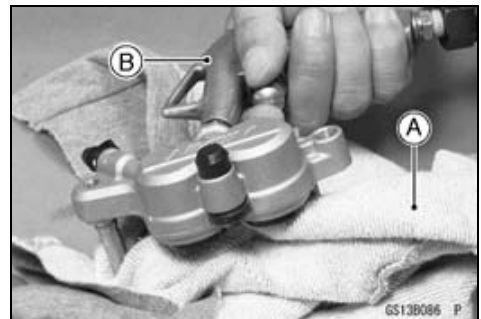
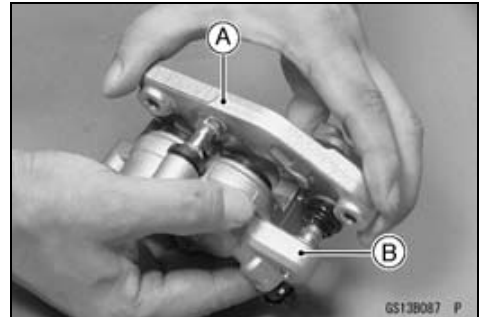

⚠ WARNING

To avoid serious injury, never place your fingers or palm in front of the piston. If you apply compressed air into the caliper, the piston may crush your hand or fingers.

- Pull out the piston [A] by hand.
- Remove the dust seals [B] and fluid seals [C].

NOTE

- If compressed air is not available, do as follows for both calipers coincidentally, with the brake hose connected to the caliper.
- Prepare a container for brake fluid, and perform the work above it.
- Remove the spring and pads (see Brake Pad Removal in the Brakes chapter).
- Pump the brake lever until the pistons come out of the cylinders, and then disassemble the caliper.

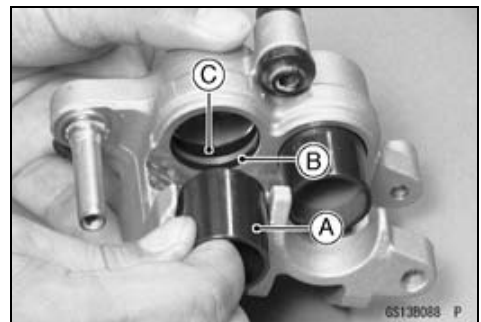

2-42 PERIODIC MAINTENANCE

Periodic Maintenance Procedures

- Remove the rear caliper (see Caliper Removal in the Brakes chapter).
- Remove the pads (see Brake Pad Removal in the Brakes chapter).
- Separate the caliper holder [B] from the caliper [A].

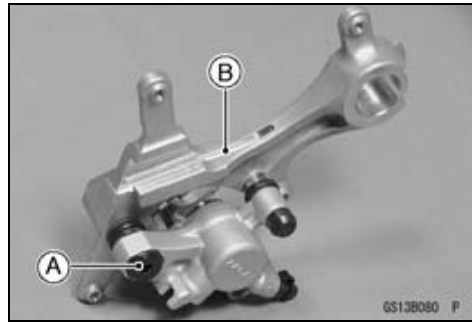

- Using compressed air, remove the piston.
 - Cover the caliper opening with a clean, heavy cloth [A].
 - Remove the piston by lightly applying compressed air [B] to where the brake line fits into the caliper.

⚠ WARNING

To avoid serious injury, never place your fingers or palm inside the caliper opening. If you apply compressed air into the caliper in such condition, the piston may crush your hand or finger.

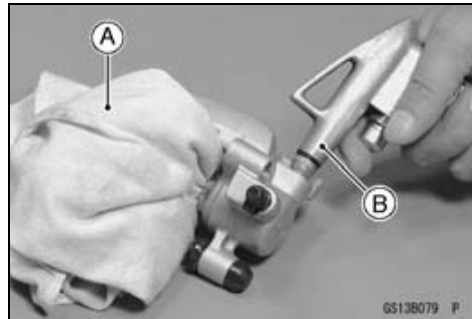

- Pull out the piston [A] by hand.
- Remove the dust seal [B] and fluid seal [C].
- Clean the caliper parts except for the pads.

CAUTION

For cleaning of the parts, use only disc brake fluid, isopropyl alcohol, or ethyl alcohol.

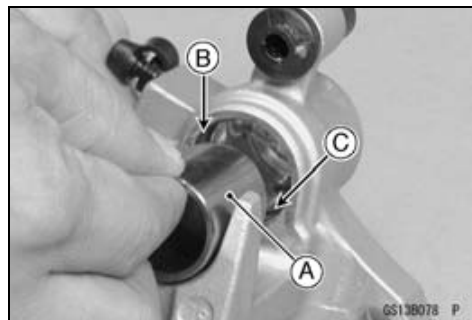

- The bleed valve was removed, install the bleed valve and rubber cap.

Torque - Bleed Valve: 7.8 N·m (0.80 kgf·m, 69 in·lb)

- Replace the fluid seal(s) [A] with new ones.
 - Apply brake fluid to the fluid seal(s), and install them into the cylinders by hand.
- Replace the dust seal(s) [B] with new ones.
 - Apply brake fluid to the dust seal(s), and install them into the cylinder by hand.
- Apply brake fluid to the outside of the pistons [C], and push them into each cylinder by hand.

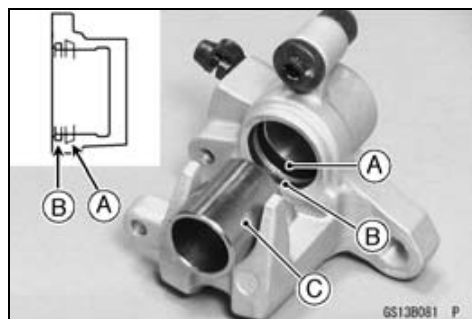
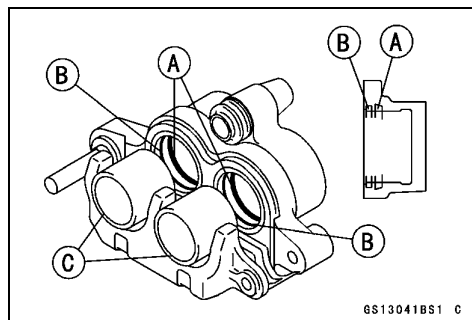

Periodic Maintenance Procedures

- Install the anti-rattle spring [A] in the caliper as shown.

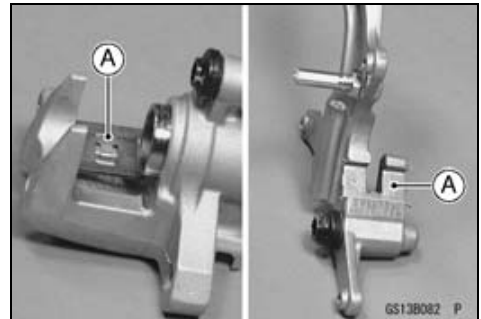
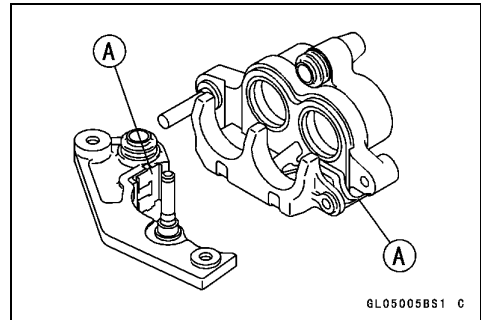

- Replace the shaft rubber boot [A] and dust boot [B] if they are damaged.
- Apply a thin coat of PBC (Poly Butyl Cuprysil) grease to the caliper holder shafts [C] and holder holes (PBC is a special high temperature, water-resistance grease).

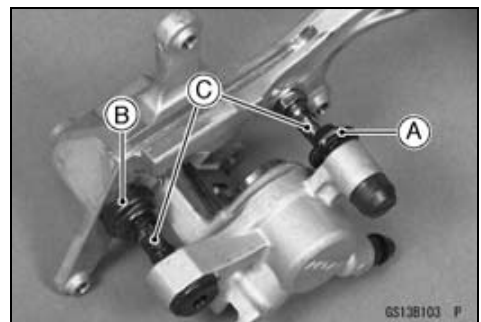
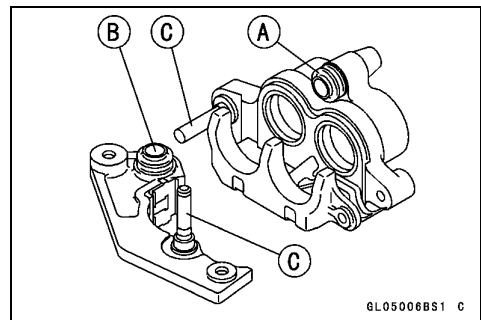

- Install the pads (see Brake Pad Installation in the Brakes chapter).
- Install the caliper (see Caliper Installation in the Brakes chapter).
- Wipe up any spilled brake fluid on the caliper with wet cloth.

2-44 PERIODIC MAINTENANCE

Periodic Maintenance Procedures

Brake Hoses and Connections Inspection

- Inspect the brake hose and fittings for deterioration, cracks and signs of leakage.
- The high pressure inside the brake line can cause fluid to leak [A] or the hose to burst if the line is not properly maintained. Bend and twist the rubber hose while examining it.
- ★ Replace the hose if any cracks [B] or bulges [C] are noticed.
- ★ Tighten any loose fittings.

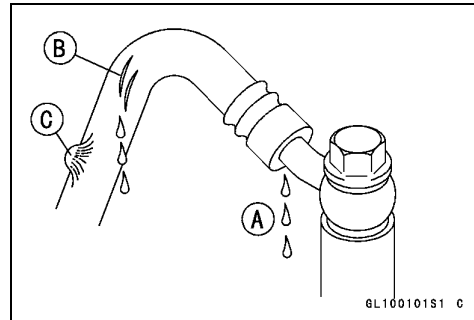

Brake Hose Replacement

CAUTION

Brake fluid quickly ruins painted surfaces; any spilled fluid should be completely washed away immediately.

- When removing the brake hose, take care not to spill the brake fluid on the painted or plastic parts.
- When removing the brake hose temporarily secure the end of the brake hose to some high place to keep fluid loss to a minimum.
- Immediately wash away any brake fluid that spills.
- Remove each banjo bolts [A] and washers [B].
- Replace the washers with new ones.

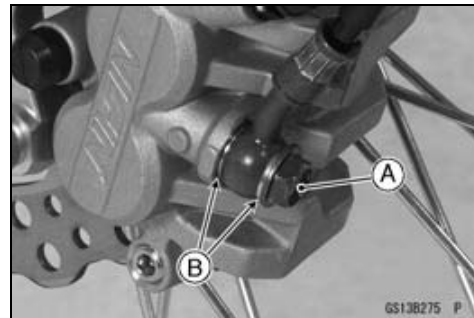

For Front Brake

- Remove:
 - Bolts [A]
 - Brake Hose Clamps [B]

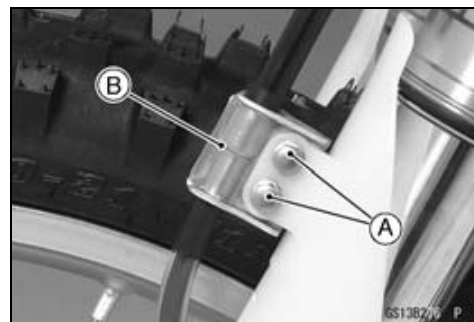

Periodic Maintenance Procedures

For Rear Brake

- Remove:
 - Master Cylinder [A]
 - Hose Clamps [B]
 - Caliper Cover [C]

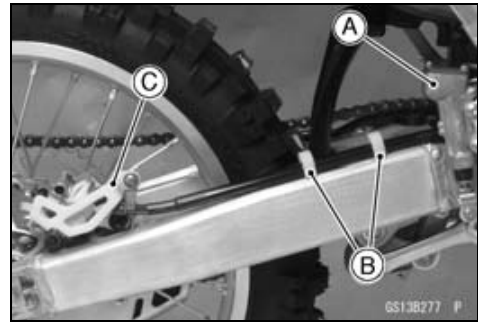

- When installing the hoses, avoid sharp bending, kinking, flattening or twisting, and route the hoses according to Cable, Wire, and Hose Routing section in the Appendix chapter.
- Tighten the banjo bolts on the hose fittings.
 - Torque - Brake Hose Banjo Bolts: 25 N·m (2.5 kgf·m, 18 ft·lb)**
- Fill the brake line after installing the brake hose (see Brake Fluid Changing).

Suspension

Front Fork Inspection

- Holding the brake lever, pump the front fork back and forth manually to check for smooth operation.
- Visually inspect the front fork for oil leakage, scoring or scratches on the outer surface of the inner tube [A].
- ★ If necessary, repair any damage.
- Nick or rust damage can sometimes be repaired by using a wet-stone to remove sharp edges or raised areas which cause seal damage.
- ★ If the damage is not repairable, replace the inner tube. Since damage to the inner tube damages the oil seal, replace the oil seal whenever the inner tube is repaired or replaced.
- If the fork is not smooth, confirm the cause.



CAUTION

If the inner tube is badly bent or creased, replace it. Excessive bending, followed by subsequent straightening, can weaken the inner tube.

Front Fork Oil Change (each fork leg) (KX450D6F ~ D7F)

- Loosen the front fork upper clamp bolts [A].



2-46 PERIODIC MAINTENANCE

Periodic Maintenance Procedures

- Loosen the fork top plug [A].
Special Tool - Top Plug Wrench, 49 mm: 57001-1653 [B]
- Remove:
 - Front Wheel (see Front Wheel Removal in the Wheels/Tires chapter)
 - Front Brake Caliper (see Caliper Removal in the Brakes chapter)
 - Brake Hose Clamps (see Brake Hose Replacement)

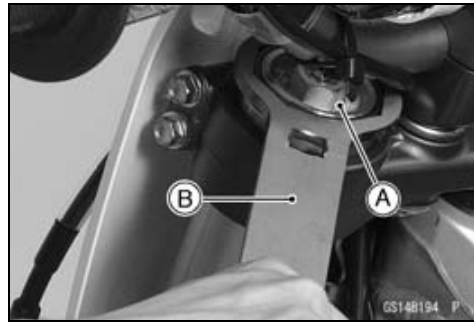

- Loosen the front fork lower clamp bolts [A].
- Remove the front fork.
 - With a twisting motion, work the fork leg [B] down and out.

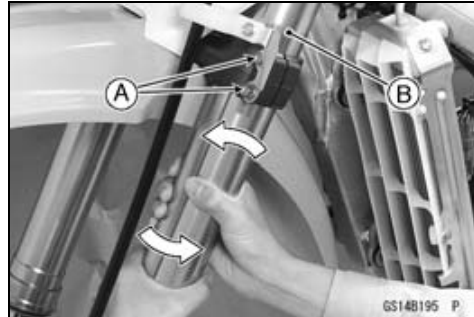

NOTE

- Set rebound and compression damping setting to the softest settings before disassembling to prevent the needle of adjusters from damaging. Record the setting before turning the adjuster.

- Thoroughly clean the fork before disassembly.

CAUTION

Be careful not scratch the inner tube and not to damage the dust seal.
Avoid scratching or damaging the inner tube or the dust seal. Use a mild detergent and sponge out dirt with plenty of water.

- Using the top plug wrench [A], remove the fork top plug [B] (subtank) from the outer tube and slowly slide down the outer tube [C].

Special Tool - Top Plug Wrench, 49 mm: 57001-1653

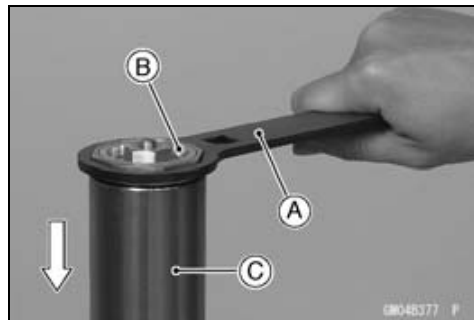

Periodic Maintenance Procedures

- Place a oil pan under the front fork and drain fork oil [A].

NOTE

○Pump the fork tube several times to discharge the fork oil.



- Raise the outer tube and temporarily install the fork top plug [A] (subtank) to the outer tube [B] with the top plug wrench [C].

Special Tool - Top Plug Wrench, 49 mm: 57001-1653

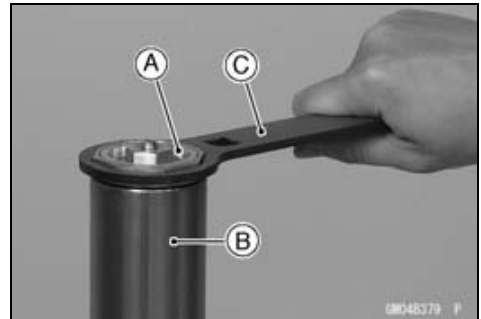

- Hold the axle holder [A] with a vise.
- Protect the axle holder with a rag when using a vise.
- Loosen the adjuster assembly [B] completely.

⚠ WARNING

Clamping the axle holder too tight can damage it which will affect riding stability. Do not clamp the axle holder too tight.

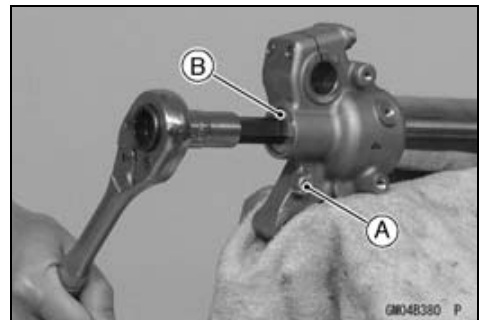

- Compress the outer tube by hands and install the top plug wrench [A] between the axle holder bottom [B] and locknut [C].

Special Tool - Top Plug Wrench, 49 mm: 57001-1653

⚠ WARNING

Be careful of reaction force in spring and fix surely so that the special tool should not come off. Do not place the finger etc. while servicing.

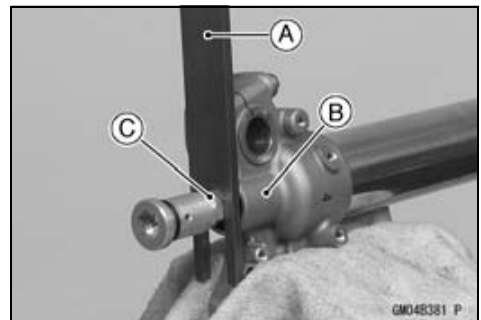

- Hold the locknut [A] with a wrench [B] and remove the adjuster assembly [C].

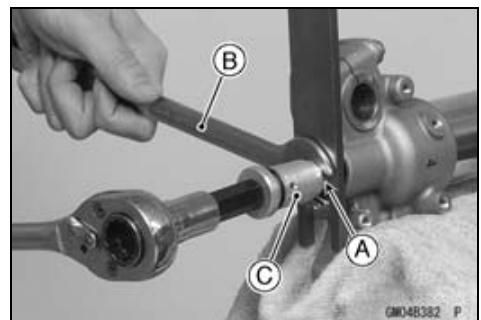

2-48 PERIODIC MAINTENANCE

Periodic Maintenance Procedures

- Remove the push rod [A].

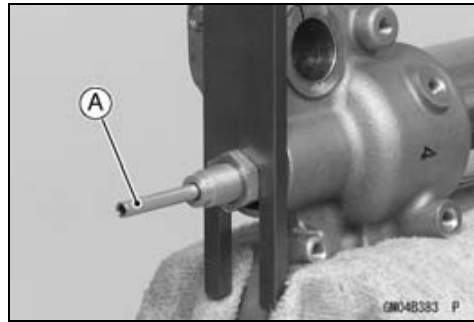

- With the outer tube compressed by hands, remove the top plug wrench [A].

CAUTION

Removing the locknut and pushing the piston rod thread into the cylinder unit will damage the oil seal. Do not remove the locknut from the piston rod.

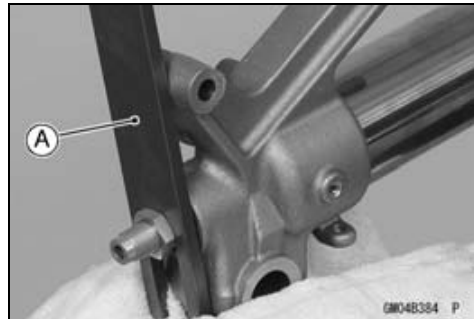

- Remove the fork leg from the vise.
- Loosen the fork top plug (subtank) [A] with the top plug wrench [B].
Special Tool - Top Plug Wrench, 49 mm: 57001-1653 [B]

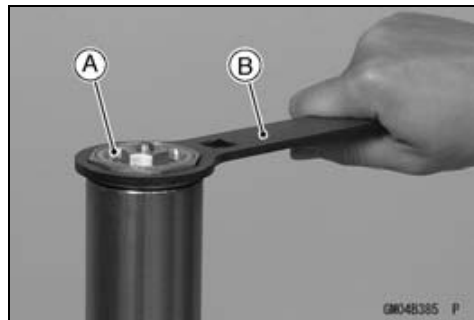

- Remove:
 - Cylinder Unit [A]
 - Spring Seat [B]
 - Spacer [C]
 - Washer [D]
 - Fork Spring [E]

CAUTION

Disassembling the cylinder unit can lead to trouble. Do not disassemble the cylinder unit.

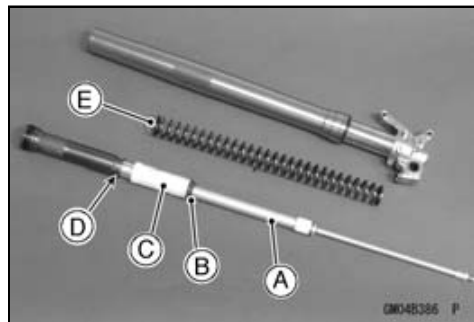

- Holding the top plug wrench [A] with a vise, loosen the base valve assembly [B] on the subtank [C].
Special Tool - Top Plug Wrench, 49 mm: 57001-1653

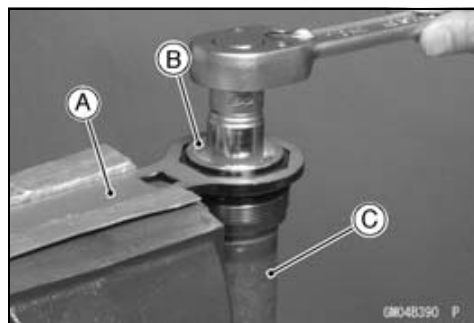

Periodic Maintenance Procedures

- Remove the base valve assembly [A] from the subtank [B].

NOTE

○ Slowly compress the piston rod until it stops so that the base valve assembly can be removed easily.

CAUTION

**Disassembling the base valve assembly can lead to trouble.
Do not disassemble the base valve assembly.**

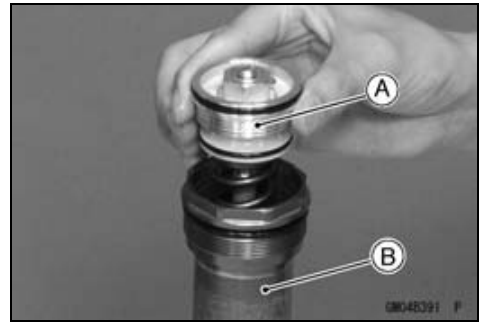

- Drain the fork oil [A] from the cylinder unit [B] by pumping the piston rod several times.

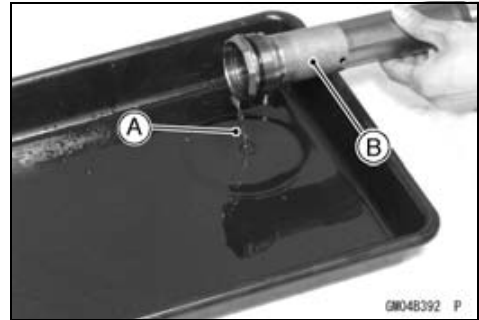

- Hold the front fork inverted position for more than 20 minutes to allow the fork oil to fully drain.

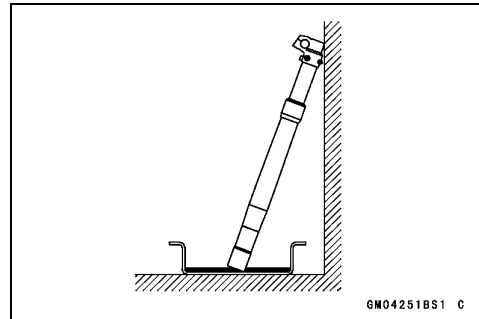

- Clean the threads [A] of subtank and base valve assembly.



- With the piston rod in fully compressed position, pour the specified amount of fork oil [A].

Recommended Oil: KHL15-10 (KAYABA01) or equivalent

Recommended Quantity: 170 ml (5.75 US oz.) (KX450D6F)

191 ml (6.46 US oz.)

NOTE

○ Plug the two oil holes on the subtank [B] with fingers.



2-50 PERIODIC MAINTENANCE

Periodic Maintenance Procedures

- Pump [A] the piston rod [B] slowly several times to expel air.

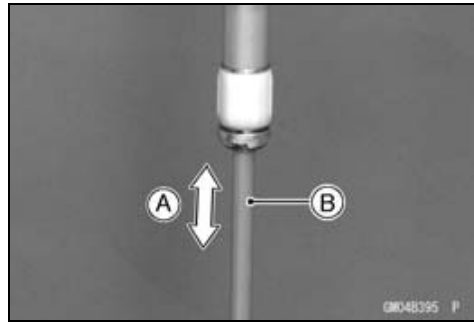

- Replace the O-rings [A] on the base valve assembly with new ones.
- Apply specified fork oil to the O-rings [A] [B] and bushings [C] on the base valve assembly.

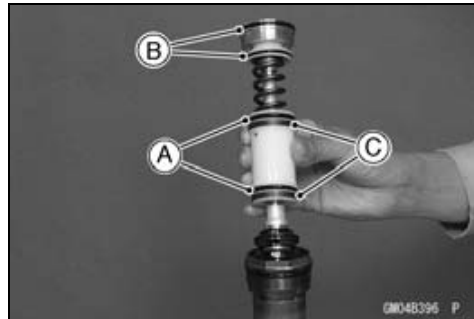

- With the piston rod held immovable in fully compressed position [A], gently install the base valve assembly [B] to the subtank.
- Screw in the base valve assembly in the subtank when the piston rod extends.

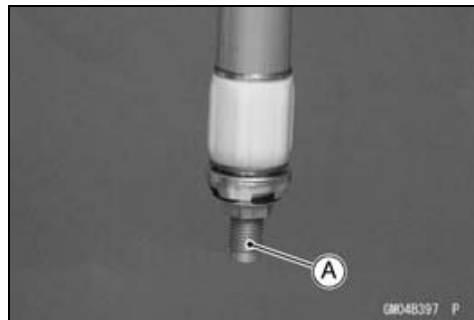

NOTE

○When it is hard to screw in the base valve assembly, pull down the piston rod a little.

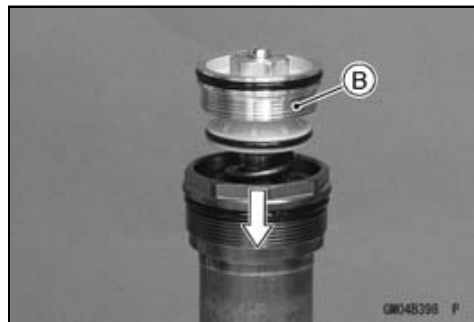

- Holding the top plug wrench [A] with a vise.
Special Tool - Top Plug Wrench, 49 mm: 57001-1653
- Holding the subtank [B] with the top plug wrench, torque the base valve assembly [C].
Torque - Base Valve Assembly: 28 N·m (2.9 kgf·m, 21 ft·lb)

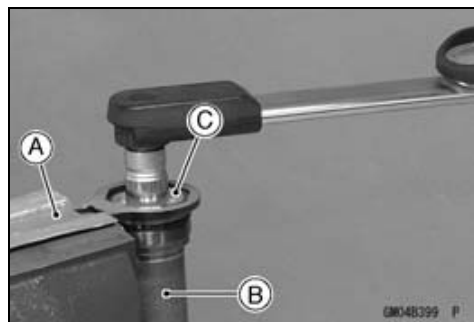

Periodic Maintenance Procedures

- Protect the piston rod end [A] with a rag [B] to prevent fork damage.
- Discharge the extra oil off the cylinder unit by pumping [C] the piston rod to full stroke.

CAUTION

Be careful not to bend or damage the piston rod when the piston rod is stroked. Service carefully because oil files out from the oil hole of the cylinder unit.

NOTE

- *Set the compression damper setting to the softest.*
 - *Check the piston rod sliding surface for damage.*
 - *Apply fork oil to the piston rod sliding surface.*
- Drain the extra oil from the subtank oil hole [A].

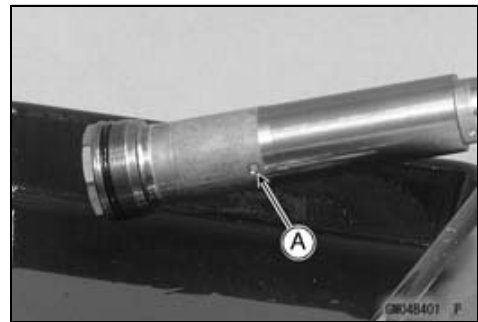
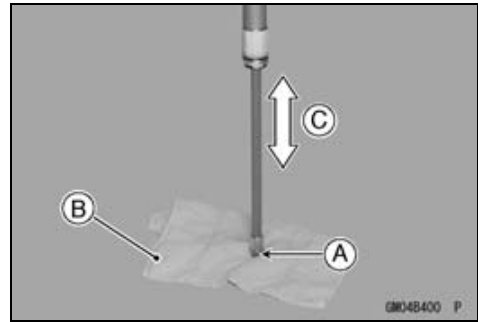

- With the cylinder unit in horizontal position, move [A] the piston rod [B] by hand to inspect it if operating smoothly.
- If the piston rod is not extend, remove the base valve assembly and perform the air bleeding (pour the specified amount fork oil and discharge an excess of oil).

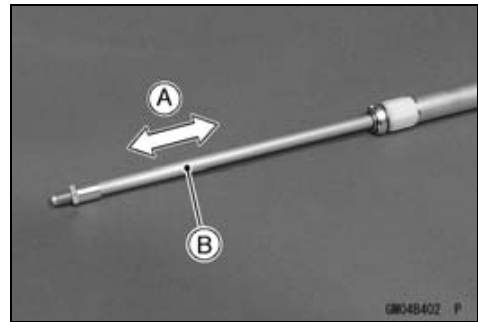

- Make sure about 16 mm (0.63 in.) [A] of push rod thread is exposed from the locknut [B].

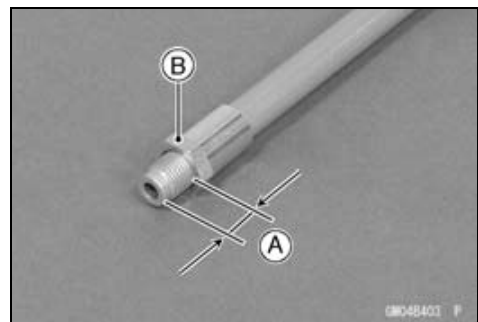

2-52 PERIODIC MAINTENANCE

Periodic Maintenance Procedures

- Completely wipe of the fork oil from the spring [A], spacer [B] and cylinder unit [C].
- Insert above-mentioned parts into the fork.

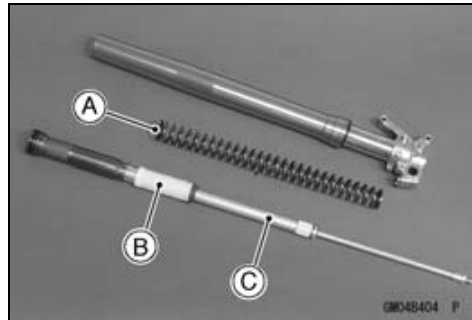

- Temporarily tighten the fork top plug [A] (subtank) using the top plug wrench.

Special Tool - Top Plug Wrench, 49 mm: 57001-1653 [B]

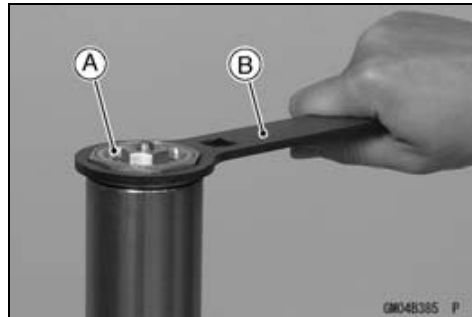

- Clamp the axle holder with a vise.
- Protect the axle holder with a rag when using a vise.

⚠ WARNING

**Clamping the axle holder too tight can damage it which will affect riding stability.
Do not clamp the axle holder too tight.**

- Compress the outer tube by hands and install the top plug wrench [A] between the axle holder bottom and locknut.
- Special Tool - Top Plug Wrench, 49 mm: 57001-1653**

⚠ WARNING

**Be careful of reaction force in spring and fix surely so that special tool should not come off.
Do not place the fingers etc. while serving.**



- Insert the push rod [A] into the piston rod.

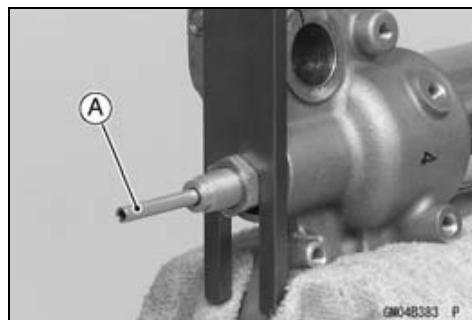

Periodic Maintenance Procedures

- Replace the O-ring and gasket on the adjuster assembly with new ones and apply specified fork oil to the O-ring.
- Slowly turn the adjuster assembly [A] clockwise until resistance is felt and check the clearance between the locknut [B] and adjuster assembly to provide more than 1 mm (0.04 in.) [C].

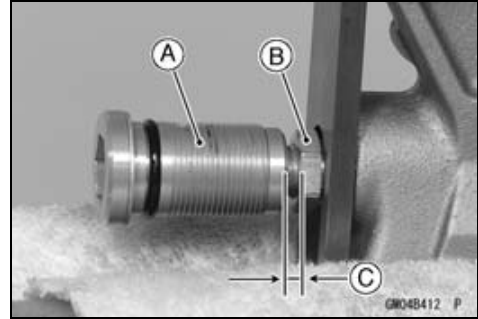

- Turn the locknut [A] counterclockwise until it contacts with the adjuster assembly [B].
- With the locknut held immovable using a wrench, tighten the adjuster assembly to the specified torque.

Torque - Locknut/Adjuster Assembly: 29 N·m (3.0 kgf·m, 22 ft·lb)

- With the outer tube compressed by hands, remove the top plug wrench.

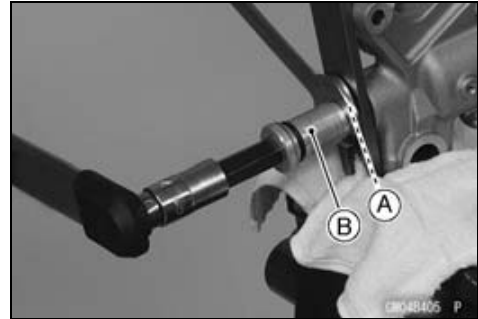

- Apply a non-permanent locking agent to the threads of a adjuster assembly.
- Torque the adjuster assembly [A].

Torque - Adjuster Assembly: 58 N·m (5.9 kgf·m, 43 ft·lb)



- Loosen and remove the fork top plug (subtank) from the outer tube and slowly slide down the outer tube.

Special Tool - Top Plug Wrench, 49 mm: 57001-1653

- Pour [A] the specified amount of fork oil into the outer tube.

Recommended Oil:	KHL15-10 (KAYABA01) or equivalent
Recommended Quantity:	345 mL (11.7 US oz.) (KX450D6F)
	(EUR) 350 mL (11.8 US oz.) (KX450D6F)
	355 mL (12.0 US oz.) (KX450D7F)



2-54 PERIODIC MAINTENANCE

Periodic Maintenance Procedures

- Raise the outer tube and temporarily tighten the fork top plug (subtank).
Special Tool - Top Plug Wrench, 49 mm: 57001-1653 [B]
- After installing the front fork, torque the top plug [A].
Special Tool - Top Plug Wrench, 49 mm: 57001-1653

The torque of fork top plug is specified to **30 N·m (3.1 kgf·m, 22 ft·lb)** however, when you use the top plug wrench (special tool) [A], reduce the torque to 90% of the specified value [**27 N·m (2.8 kgf·m, 20 ft·lb)**] due to the distance [B] between the center of the square hole, where the torque wrench is fitted, and that of the octagonal hole of the wrench.

This torque value [**27 N·m (2.8 kgf·m, 20 ft·lb)**] is applicable when you use a torque wrench whose length gives leverage of approximately 310 mm between the grip point to the center of the coupling square.

Torque - Front Fork Top Plug: 30 N·m (3.1 kgf·m, 22 ft·lb)

- Install:
 - Front Wheel (see Front Wheel Installation in the Wheels/Tires chapter)
 - Front Brake (see Caliper Installation in the Brakes chapter)
 - Brake Hose Clamps (see Brake Hose Replacement)

Front Fork Oil Change (each fork leg) (KX450D8F)

- Remove:
 - Number Plate
- Loosen the front fork upper clamp bolts [A].

- Loosen the fork top plug [A].
Special Tool - Top Plug Wrench, 49 mm: 57001-1653 [B]
- Remove:
 - Front Wheel (see Front Wheel Removal in the Wheels/Tires chapter)
 - Front Brake Caliper (see Caliper Removal in the Brakes chapter)
 - Brake Hose Clamps (see Brake Hose Replacement)

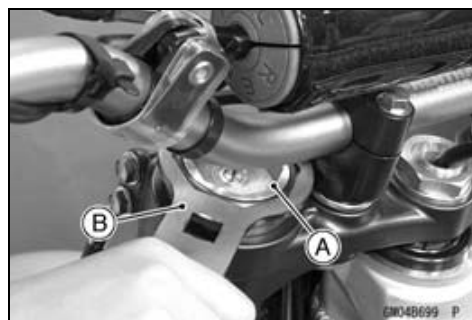
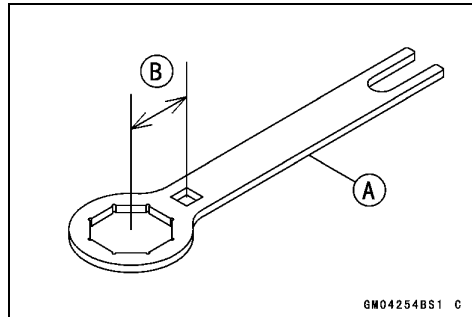
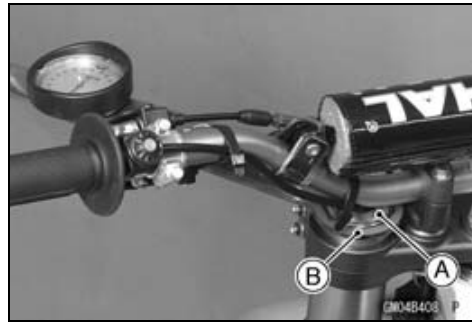

Periodic Maintenance Procedures

- Loosen the front fork lower clamp bolts [A].
- Remove the front fork.
- With a twisting motion, work the fork leg [B] down and out.

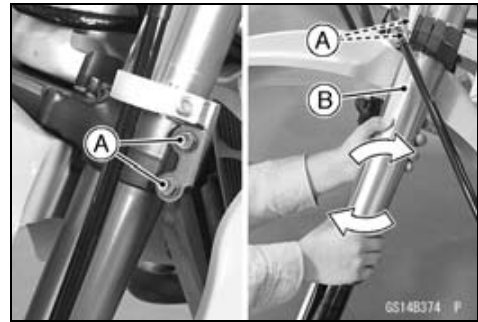

NOTE

○ Set rebound and compression damping setting to the softest settings before disassembling to prevent the needle of adjusters from damaging. Record the setting before turning the adjuster.

- Thoroughly clean the fork before disassembly.

CAUTION

Be careful not scratch the inner tube and not to damage the dust seal. Avoid scratching or damaging the inner tube or the dust seal. Use a mild detergent and sponge out dirt with plenty of water.

- Using the top plug wrench [A], remove the fork top plug [B] (subtank) from the outer tube and slowly slide down the outer tube [C].

Special Tool - Top Plug Wrench, 49 mm: 57001-1653

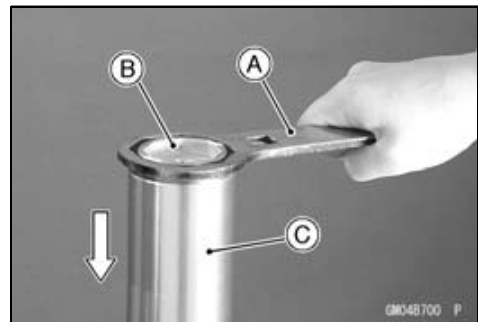

- Place a oil pan under the front fork and drain fork oil [A].

NOTE

○ Pump the fork tube several times to discharge the fork oil.

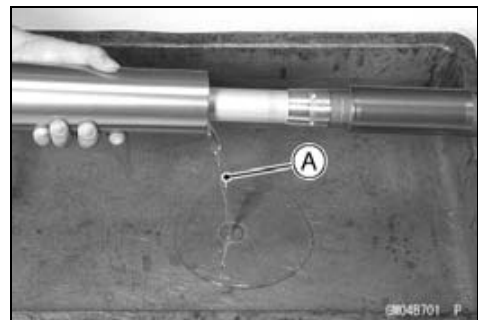

2-56 PERIODIC MAINTENANCE

Periodic Maintenance Procedures

- Raise the outer tube and temporarily install the fork top plug [A] (subtank) to the outer tube [B] with the top plug wrench [C].

Special Tool - Top Plug Wrench, 49 mm: 57001-1653

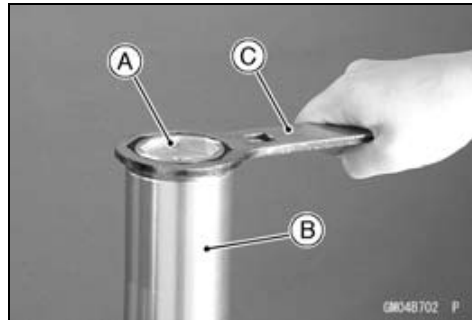

- Hold the axle holder [A] with a vise.
- Protect the axle holder with a rag when using a vise.
- Loosen the adjuster assembly [B] completely.

⚠ WARNING

Clamping the axle holder too tight can damage it which will affect riding stability.
Do not clamp the axle holder too tight.

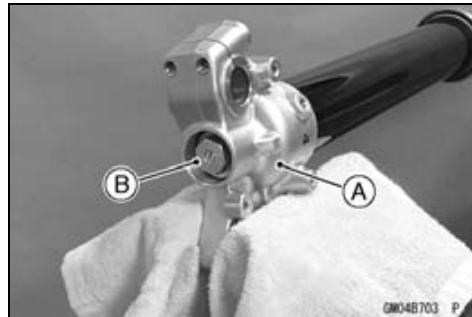

- Compress the outer tube by hands and install the top plug wrench [A] between the axle holder bottom [B] and locknut [C].

Special Tool - Top Plug Wrench, 49 mm: 57001-1653

⚠ WARNING

Be careful of reaction force in spring and fix surely so that the special tool should not come off. Do not place the finger etc. while servicing.

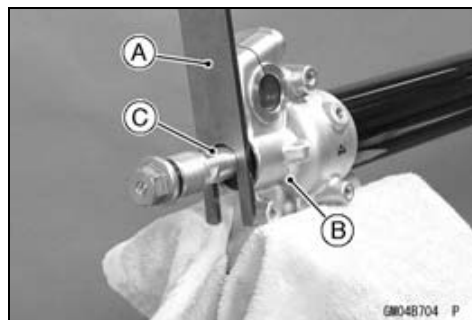

- Hold the locknut [A] with a wrench [B] and remove the adjuster assembly [C].

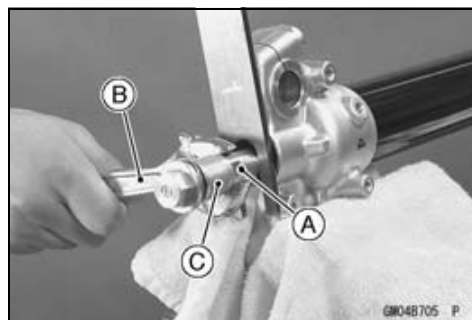

- Remove the push rod [A].

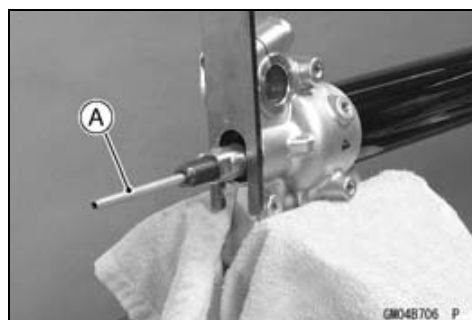

Periodic Maintenance Procedures

- With the outer tube compressed by hands, remove the top plug wrench [A].

CAUTION
Removing the locknut and pushing the piston rod thread into the cylinder unit will damage the oil seal. Do not remove the locknut from the piston rod.

- Remove the fork leg from the vise.
- Loosen the fork top plug (subtank) [A] with the top plug wrench [B].
Special Tool - Top Plug Wrench, 49 mm: 57001-1653 [B]

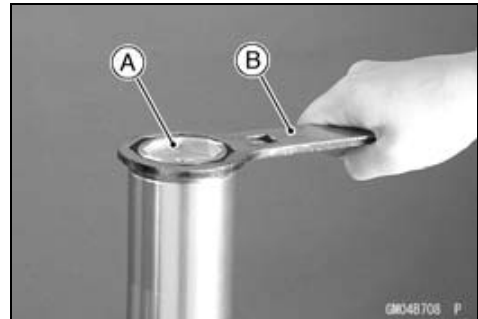

- Remove:
Cylinder Unit [A]
Spacer [B]
Fork Spring [C]

CAUTION
Disassembling the cylinder unit can lead to trouble. Do not disassemble the cylinder unit.

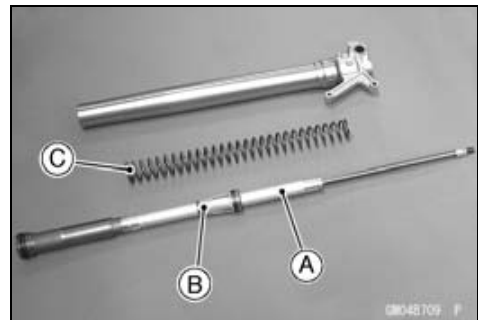

- Holding the top plug wrench (57001-1653) [A] with a vise, loosen the base valve assembly [B] using the top plug wrench (57001-1705) [C].
Special Tool - Top Plug Wrench, 49 mm: 57001-1653
Top Plug Wrench, 36 mm: 57001-1705

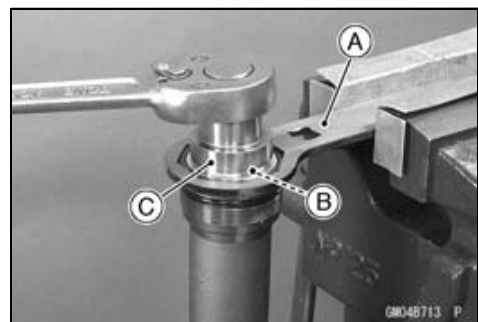

- Remove the base valve assembly [A] from the subtank [B].

NOTE

○ Slowly compress the piston rod until it stops so that the base valve assembly can be removed easily.

CAUTION
Disassembling the base valve assembly can lead to trouble. Do not disassemble the base valve assembly.



2-58 PERIODIC MAINTENANCE

Periodic Maintenance Procedures

- Drain the fork oil [A] from the cylinder unit [B] by pumping the piston rod several times.

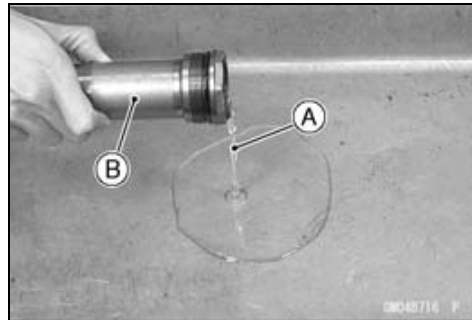

- Hold the front fork inverted position for more than 20 minutes to allow the fork oil to fully drain.

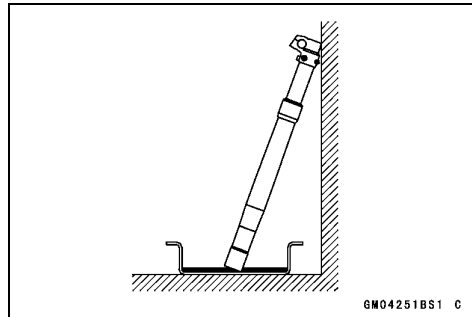

- Clean the threads [A] of subtank and base valve assembly.



- With the piston rod in fully compressed position, pour the specified amount of fork oil [A].

Recommended Oil: KHL15-10 (KAYABA01) or equivalent

Recommended Quantity: 191 ml (6.46 US oz.)

NOTE

○ Plug the two oil holes on the subtank [B] with fingers.

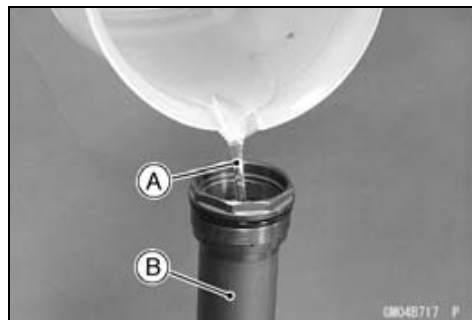

- Pump [A] the piston rod [B] slowly several times to expel air.

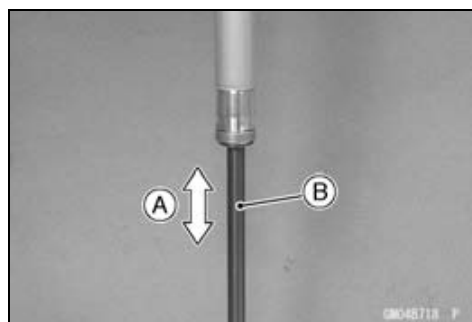

Periodic Maintenance Procedures

- Replace the O-rings [A] on the base valve assembly with new ones.
- Apply specified fork oil to the O-rings [A] [B] and bushings [C] on the base valve assembly.

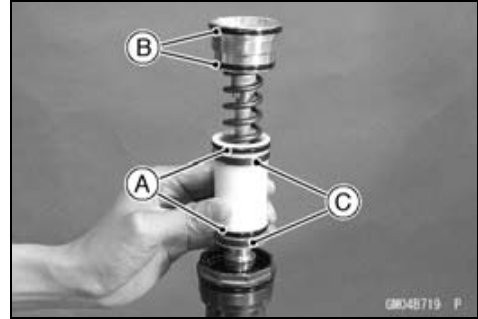

- With the piston rod held immovable in fully compressed position [A], gently install the base valve assembly [B] to the subtank.
- Screw in the base valve assembly in the subtank when the piston rod extends.

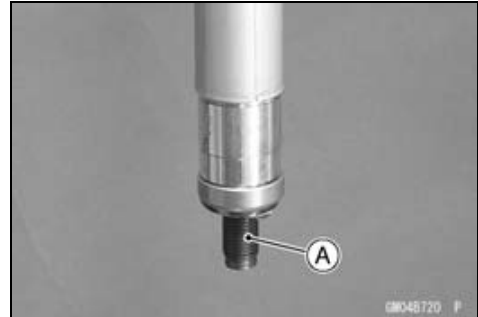

NOTE

○When it is hard to screw in the base valve assembly, pull down the piston rod a little.



- Holding the top plug wrench (57001-1653) [A] with a vise.
Special Tool - Top Plug Wrench, 49 mm: 57001-1653
Top Plug Wrench, 36 mm: 57001-1705
- Holding the subtank [B] with the top plug wrench, torque the base valve assembly [C] using the top plug wrench (57001-1705) [D].

Torque - Base Valve Assembly: 28 N·m (2.9 kgf·m, 21 ft·lb)

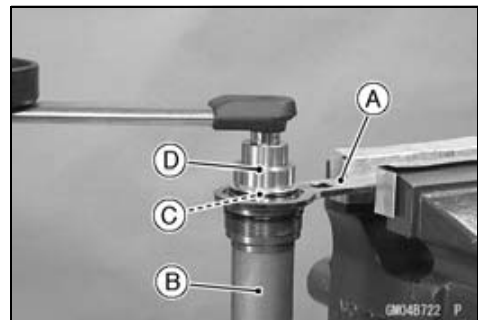

- Protect the piston rod end [A] with a rag [B] to prevent fork damage.
- Discharge the extra oil off the cylinder unit by pumping [C] the piston rod to full stroke.

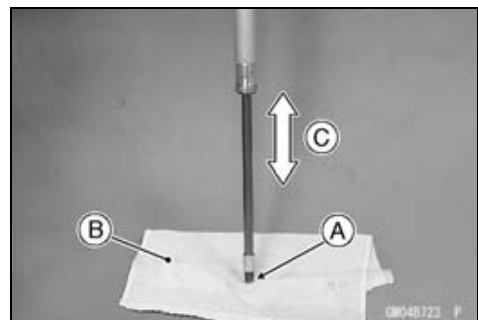

CAUTION

Be careful not to bend or damage the piston rod when the piston rod is stroked. Service carefully because oil files out from the oil hole of the cylinder unit.

NOTE

- Set the compression damper setting to the softest.
- Check the piston rod sliding surface for damage.
- Apply fork oil to the piston rod sliding surface.

2-60 PERIODIC MAINTENANCE

Periodic Maintenance Procedures

- Drain the extra oil from the subtank oil hole [A].

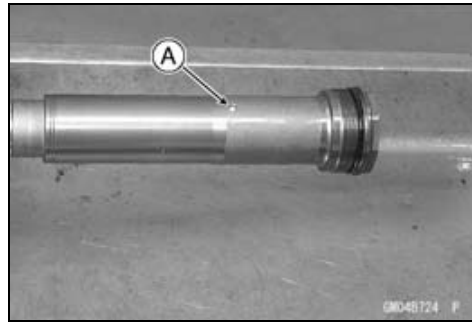

- With the cylinder unit in horizontal position, move [A] the piston rod [B] by hand to inspect it if operating smoothly.
- If the piston rod is not extend, remove the base valve assembly and perform the air bleeding (pour the specified amount fork oil and discharge an excess of oil).

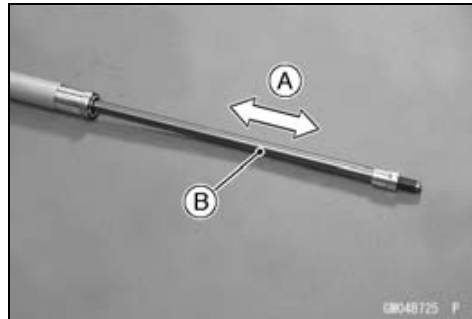

- Make sure about 16 mm (0.63 in.) [A] of push rod thread is exposed from the locknut [B].

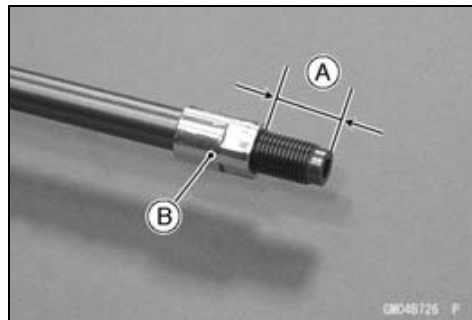

- Completely wipe of the fork oil from the spring [A], spacer [B] and cylinder unit [C].
- Insert above-mentioned parts into the fork.

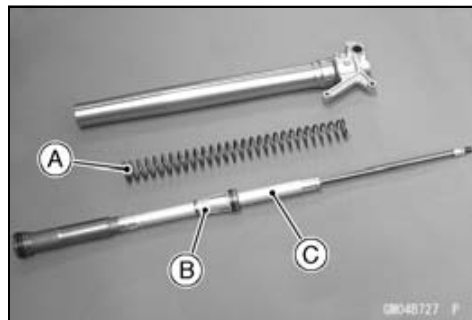

- Temporarily tighten the fork top plug [A] (subtank) using the top plug wrench.

Special Tool - Top Plug Wrench, 49 mm: 57001-1653 [B]

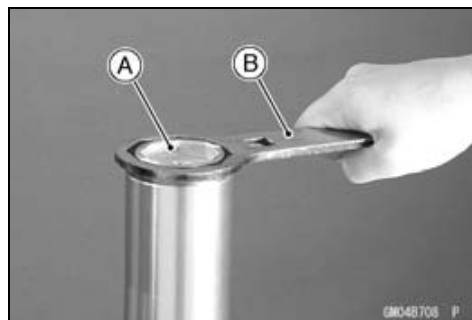

Periodic Maintenance Procedures

- Clamp the axle holder with a vise.
- Protect the axle holder with a rag when using a vise.

⚠ WARNING
Clamping the axle holder too tight can damage it which will affect riding stability.
Do not clamp the axle holder too tight.

- Compress the outer tube by hands and install the top plug wrench [A] between the axle holder bottom and locknut.
- Special Tool - Top Plug Wrench, 49 mm: 57001-1653**

⚠ WARNING
Be careful of reaction force in spring and fix surely so that special tool should not come off.
Do not place the fingers etc. while serving.

- Insert the push rod [A] into the piston rod.

- Replace the O-ring and gasket on the adjuster assembly with new ones and apply specified fork oil to the O-ring.
- Slowly turn the adjuster assembly [A] clockwise until resistance is felt and check the clearance between the locknut [B] and adjuster assembly to provide more than 1 mm (0.04 in.) [C].

- Turn the locknut [A] counterclockwise until it contacts with the adjuster assembly [B].
- With the locknut held immovable using a wrench, tighten the adjuster assembly to the specified torque.

Torque - Locknut/Adjuster Assembly: 29 N·m (3.0 kgf·m, 22 ft·lb)

- With the outer tube compressed by hands, remove the top plug wrench.

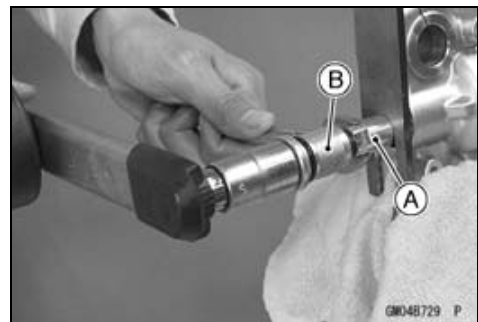
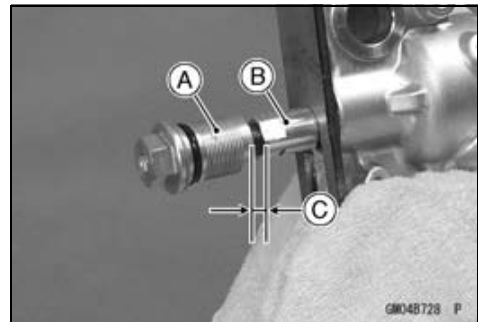
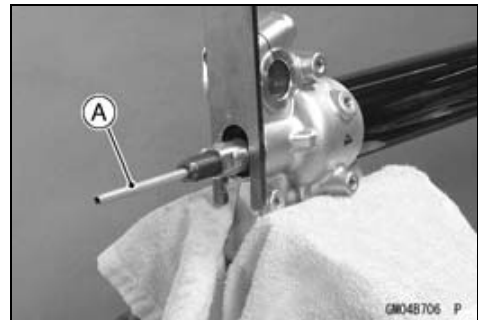

2-62 PERIODIC MAINTENANCE

Periodic Maintenance Procedures

- Apply a non-permanent locking agent to the threads of a adjuster assembly.
- Torque the adjuster assembly [A].

Torque - Adjuster Assembly: 58 N·m (5.9 kgf·m, 43 ft·lb)

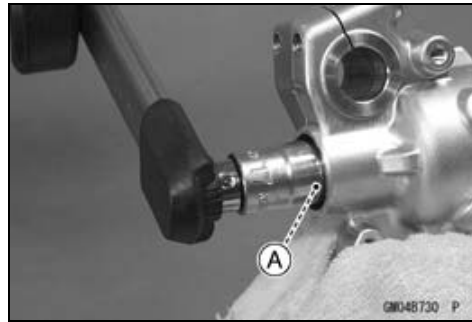

- Loosen and remove the fork top plug (subtank) from the outer tube and slowly slide down the outer tube.

Special Tool - Top Plug Wrench, 49 mm: 57001-1653

- Pour [A] the specified amount of fork oil into the outer tube.

Recommended Oil: KHL15-10 (KAYABA01) or equivalent

Recommended Quantity: 350 mL (11.8 US oz.)

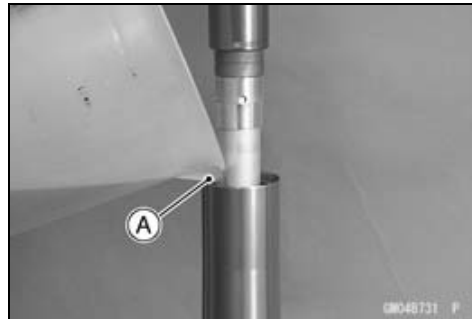

- Raise the outer tube and temporarily tighten the fork top plug (subtank).

Special Tool - Top Plug Wrench, 49 mm: 57001-1653 [B]

- After installing the front fork, torque the top plug [A].

Special Tool - Top Plug Wrench, 49 mm: 57001-1653



The torque of fork top plug is specified to **30 N·m (3.1 kgf·m, 22 ft·lb)** however, when you use the top plug wrench (special tool) [A], reduce the torque to 90% of the specified value [**27 N·m (2.8 kgf·m, 20 ft·lb)**] due to the distance [B] between the center of the square hole, where the torque wrench is fitted, and that of the octagonal hole of the wrench.

This torque value [**27 N·m (2.8 kgf·m, 20 ft·lb)**] is applicable when you use a torque wrench whose length gives leverage of approximately 310 mm between the grip point to the center of the coupling square.

Torque - Front Fork Top Plug: 30 N·m (3.1 kgf·m, 22 ft·lb)

- Install:
 - Front Wheel (see Front Wheel Installation in the Wheels/Tires chapter)
 - Front Brake (see Caliper Installation in the Brakes chapter)
 - Brake Hose Clamps (see Brake Hose Replacement)

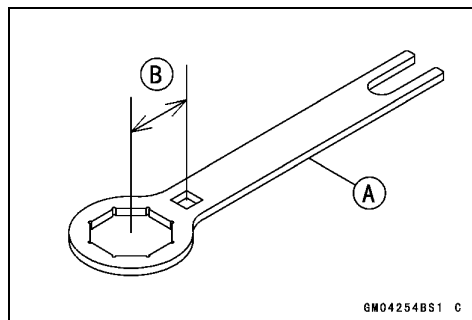

Periodic Maintenance Procedures

Rear Shock Absorber Inspection

- Bounce [A] the rear of the motorcycle up and down and check for smooth suspension stroke.
- Remove the rear frame (see Rear Frame Removal in the Frame chapter).
- Check for a broken or collapsed spring.
- Check the shock for a bent shaft or oil leaks.
- ★ If the shock does not smoothly or damaged, replace or repair defective parts.



Rear Shock Absorber Oil Change

The oil should be changed in the rear shock absorber at least once per racing season. The frequency for best performance must be based upon riding conditions and rider ability.

- Remove the rear shock absorber from the frame (see Rear Shock Absorber Removal in the Suspension chapter).
- Remove the shock absorber spring (see Spring Replacement in the Suspension chapter).
- Point the valve [A] away from you. Slowly release nitrogen gas pressure from the gas reservoir by pushing down the valve core with a screw driver.

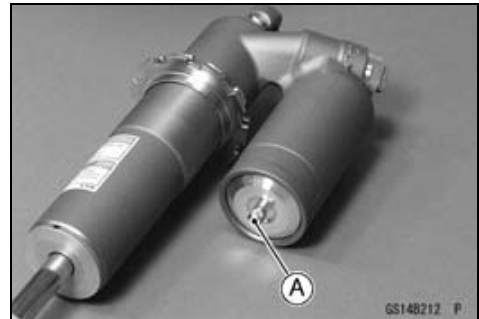

⚠ WARNING

Do not point the reservoir valve toward your face or body when releasing nitrogen gas pressure. An oil mist is often released with the nitrogen. Always release nitrogen gas pressure before disassembling the rear shock absorber to prevent explosive separation of parts.

- Adjust the gas reservoir damping adjusters [A] to the softest position.
- Remove the air bleed bolt [B] and pump the rear shock to drain the oil out the rear shock body.
- Install the air bleed bolt.

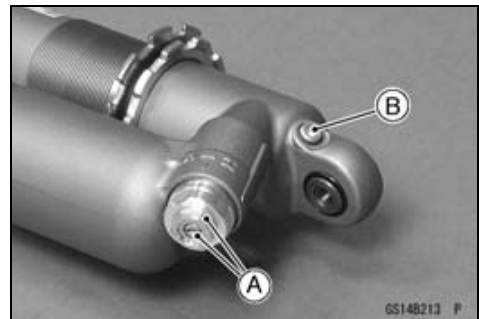

2-64 PERIODIC MAINTENANCE

Periodic Maintenance Procedures

- Using the suitable tool [A] and press, push the reservoir cap [B] in 10 mm (0.39 in.).
- Remove the circlip [C] from the gas reservoir.

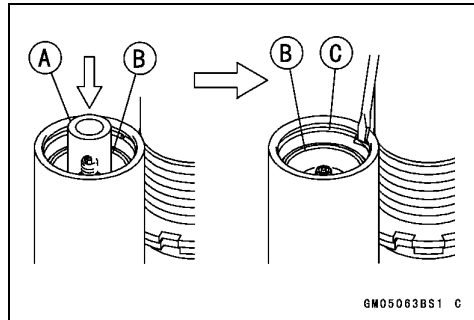

- Pull the gas reservoir cap [B] out of the gas reservoir using the pliers [A].

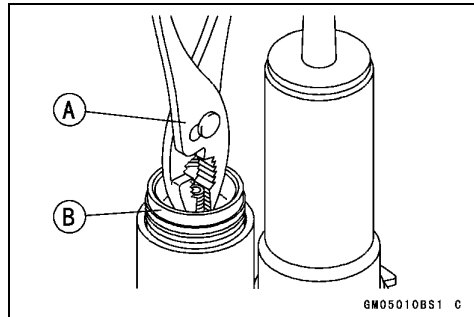

- Pry or tap [A] at the gaps [B] in the stop [C] with suitable tools to free the stop from the rear shock body [D].

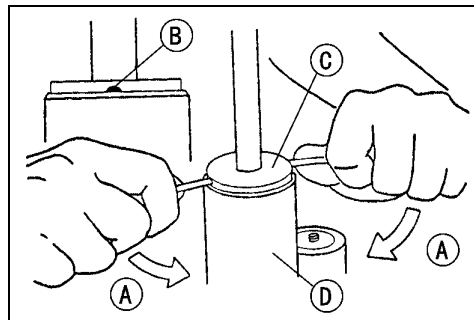

- Slide the stop up the top of the piston rod then lightly tap around the seal with a suitable rod and mallet, and push the seal assembly 10 mm (0.39 in.) down.
- Remove the circlip [A].
- Lightly move the piston rod back and forth, and pull out the piston rod assembly.
- Pour the oil out of the rear shock body into the suitable container.

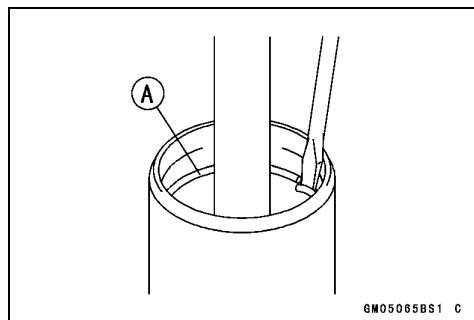

- Visually inspect the piston [A], O-ring [B], and oil seal assy [C].
- If the piston, O-ring and oil seal assy are badly scored, rusty or damaged, replace them.

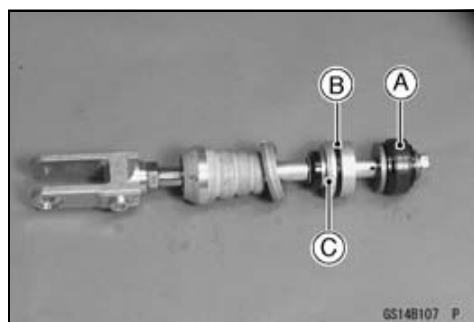

Periodic Maintenance Procedures

- Using the grinder, shave off the stop portion [A] of the rod.
- Remove:
 - Nut [B]
 - Washer [C]
 - Piston [D]
- Install the new piston and tighten the locknut.
- Discard a washer or two.

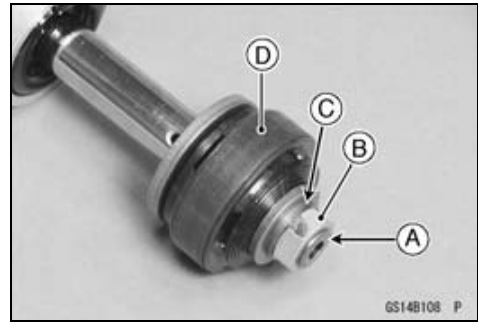

- Pour KYB K2-C (SAE 5W or Bel-Ray SE2 #40) oil into the gas reservoir to 60 ~ 70 mm (2.63 ~ 2.76 in.) [A] from the gas reservoir upper end.

Recommended Oil: K2-C (KAYABA) or equivalent

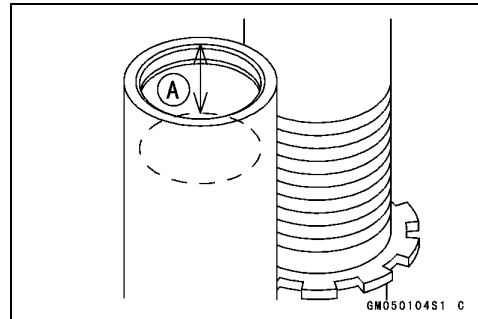

- Check that the bladder [A] on the gas reservoir cap is not partially collapsed.
- ★ If it is, push down the valve core with a screwdriver.
- Check the bladder for sign of damage or crack.
- ★ If necessary, replace it with a new one.

CAUTION

Do not use a damaged or partially collapsed bladder, because it may burst, gently reducing rear shock performance. .

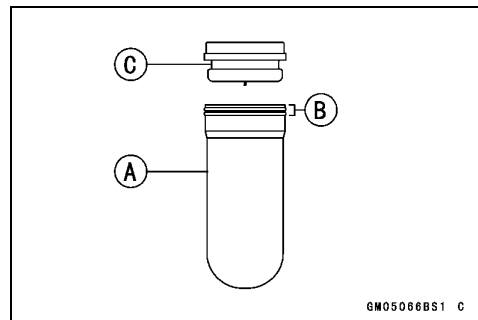

- Apply grease to the lip [B] of the bladder and install the reservoir cap [C].
- Push the bladder into the gas reservoir slowly until it just clears the circlip groove. Wipe out any spilled oil.

CAUTION

Ensure that no air remains in the system.

- Check the circlip for weakening, deformity and flaws.
- ★ If necessary, replace it with a new one.

CAUTION

If weakened, deformed or flawed circlip is used, the gas reservoir cap may not hold when injecting the nitrogen gas. This would allow oil and internal parts to explode out of the reservoir.

2-66 PERIODIC MAINTENANCE

Periodic Maintenance Procedures

- Mount the circlip [A] in the groove in the gas reservoir.

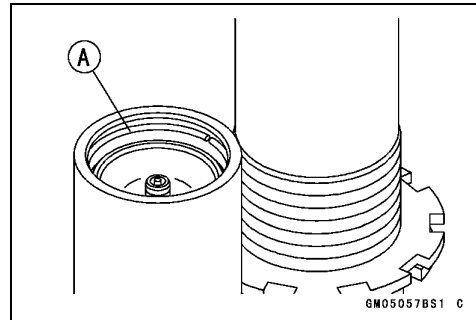

- Pull up the gas reservoir cap [A] against the circlip. The end of the gas reservoir cap must align [B] with the end of the gas reservoir [C].

⚠ WARNING

If the end of the gas reservoir cap and the end of the gas reservoir are not aligned, the circlip is not correctly fitting in the groove in the gas reservoir or is deformed. In this case, the oil and internal parts could explode out of the reservoir when injecting the nitrogen gas or while riding the motorcycle.

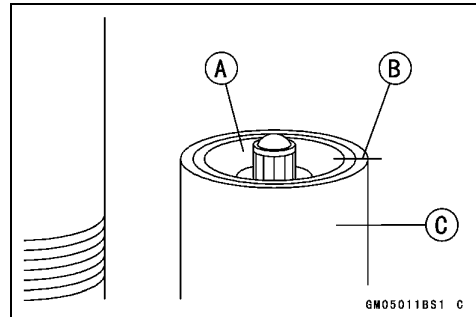

- Pour KYB K2-C (SAE 5W or Bel-Ray SE2 #40) oil into the rear shock body to 55 mm (1.77 in.) [A] from the lower end of the rear shock body [B].

Recommended Oil: K2-C (KAYABA) or equivalent

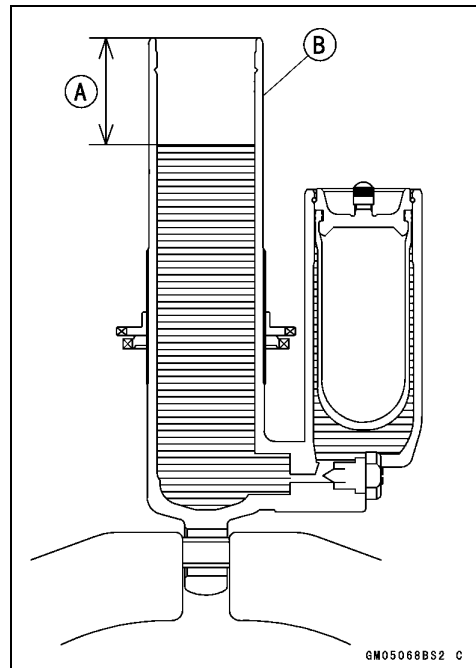

- Insert the piston end [A] of the piston rod assembly into the rear shock body [C] slowly. Do not insert the seal assembly [B] yet. Pump the piston rod until all the air is forced out of the rear shock body.

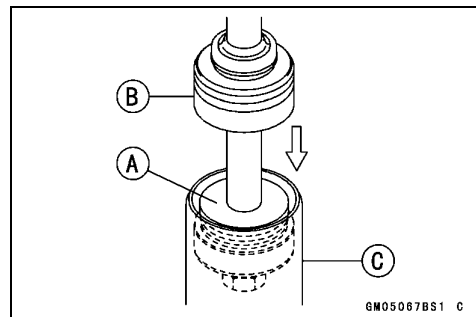

Periodic Maintenance Procedures

- Push the seal assembly into the rear shock body until it just clears the circlip groove.
- Check the circlip.
- ★ If it is deformed or damaged, replace it with a new one.
- Fit the circlip [A] into the groove in the rear shock body [B].

CAUTION

If the circlip is not a certain fit in the groove in the rear shock body, the piston rod assembly may come out of the shock absorber when injecting the nitrogen gas or riding the motorcycle.

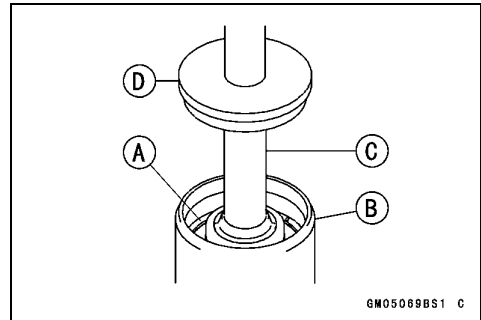

- Pull up the piston rod assembly [C] against the circlip.
- Force the stop [D] into the rear shock body by lightly tapping around the edge of the stop with a mallet.
- Fully extend the piston rod assembly.

- Install the suitable oil cup [A] to the air bleed bolt hole, and fill the specified oil into the cup.
- Purge the air from between the gas reservoir [B] and rear shock body [C] by slowly pumping the piston rod [D] in and out.
- Install the air bleed bolt securely.

Torque - Air Bleed Bolt: 6.4 N·m (0.65 kgf·m, 57 in·lb)

- Fully extend the push rod assembly.

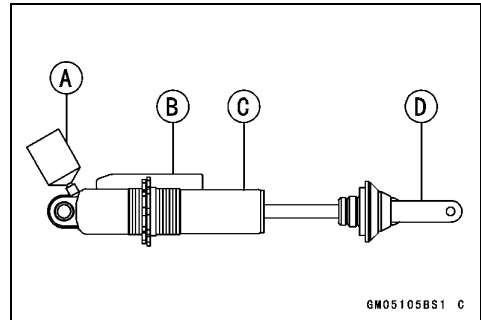

- Inject nitrogen gas to a pressure of 50 kPa (0.5 kgf/cm², 7 psi) through the valve on the gas reservoir.
- Check the rear shock body and gas reservoir for oil and gas leaks.
- ★ If there are no leaks, inject the nitrogen gas up to the 980 kPa (10 kgf/cm², 142 psi) pressure.

⚠ WARNING

Pressurize the gas reservoir with nitrogen gas only. Do not use air or other gases, since they may cause premature wear, rust, fire hazard or substandard performance. High pressure gas is dangerous. Have a qualified mechanic perform this procedure.

- Install the spring and spring guide.
- Adjust spring preload. Reinstall the rear shock absorber.
- Install the parts removed.

2-68 PERIODIC MAINTENANCE

Periodic Maintenance Procedures

Swingarm and Uni-Trak Linkage Inspection

- Check the uni-trak component parts for wear periodically, or whenever excessive play is suspected.
- Using the jack under the frame, raise the rear wheel off the ground.

Special Tool - Jack: 57001-1238

- Push and pull on the swingarm [A], up and down, to check for wear.
- ★ A small amount of play on the swingarm is normal and no corrective action is needed. However, if excessive play is felt, remove the uni-trak parts from the frame and check for wear.

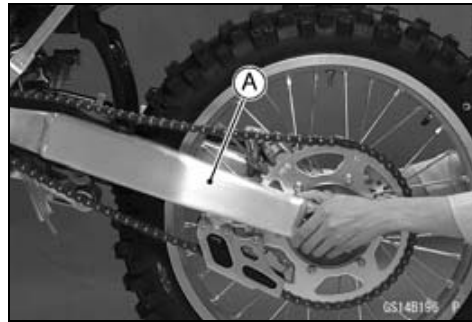

Swingarm and Uni-Track Linkage Pivot Lubrication

- Refer to the Swingarm Bearing Installation and Rocker Arm Bearing Installation in Suspension chapter.

Steering

Steering Inspection

- Using the jack, raise the front wheel off the ground.

Special Tool - Jack: 57001-1238

- With the front wheel pointing straight ahead, alternately nudge each end of the handlebar. The front wheel should swing fully left and right from the force of gravity until the fork hits the stop.
- ★ If the steering binds or catches before the stop, check the routing of the cables, hoses, and harnesses.
- ★ If the steering feels tight, adjust or lubricate the steering.
- Feel for steering looseness by pushing and pulling the forks.
- ★ If you feel looseness, adjust the steering.

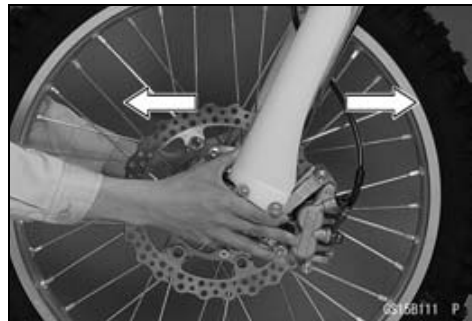

Steering Adjustment

- Using the jack, raise the front wheel off the ground.

Special Tool - Jack: 57001-1238

Periodic Maintenance Procedures

- Slide the holder belt [A] out off.
- Remove number plate bolt [B] and number plate [C].
- Remove the handlebar pad [D].

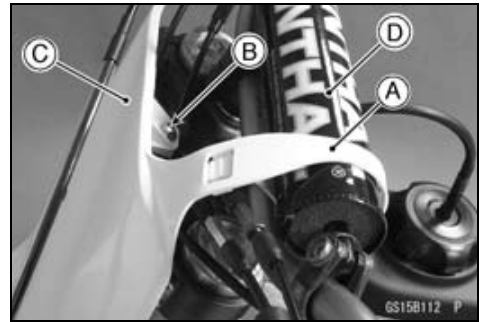

- Remove:
 Handlebar Holder Bolts [A]
 Handlebar Holders (upper) [B]
 Handlebar [C]

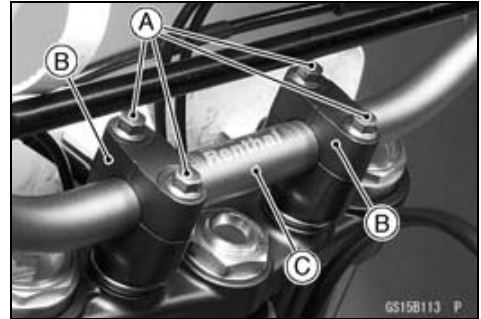

- Loosen the front fork upper clamp bolts [A], and remove the steering stem head nut [B] and steering stem head [C].

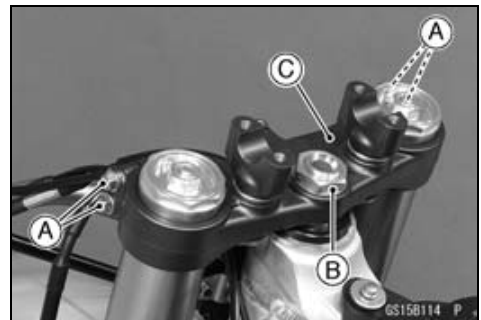

- Turn the steering stem nut [A] with the steering stem nut wrench [B] to obtain the proper adjustment.
- ★ If the steering is too tight, loosen the stem nut a fraction of a turn; if the steering is too loose, tighten the nut a fraction of a turn.

Special Tool - Steering Stem Nut Wrench: 57001-1100

NOTE

○ Turn the stem nut 1/8 turn at a time maximum.



- Install the steering stem head.
- Tighten the following:
Torque - Steering Stem Head Nut: 98 N·m (10 kgf·m, 72 ft·lb)
Front Fork Clamp Bolts (upper): 20 N·m (2.0 kgf·m, 15 ft·lb)

NOTE

○ Tighten the two clamp bolts alternately two times to ensure even tightening torque.

- Check the steering again.
- ★ If the steering is too tight or too loose, repeat the adjustment as mentioned above.

2-70 PERIODIC MAINTENANCE

Periodic Maintenance Procedures

- Install the handlebar [B] on the handlebar holder (lower) so that the protruded scales of the both side adjust to the same width [A].
- Apply 2-stroke oil to the threads of the handlebar holder bolts.
- Install the handlebar holder (upper) so that center [D] of the handlebar holder (upper) [C] and handlebar bridge [E] align.

Torque - Handlebar Holder Bolts: 25 N·m (2.5 kgf·m, 18 ft·lb)

Front [F]

- After tighten, make sure space [A] [B] of the ahead and back are same width.
- Install the handlebar pad and number plate.

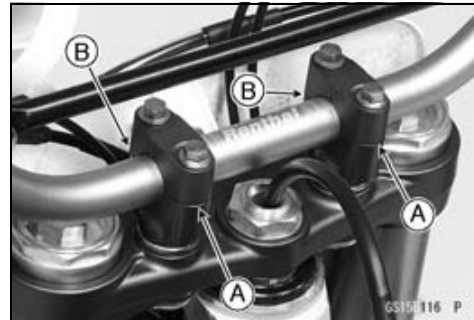
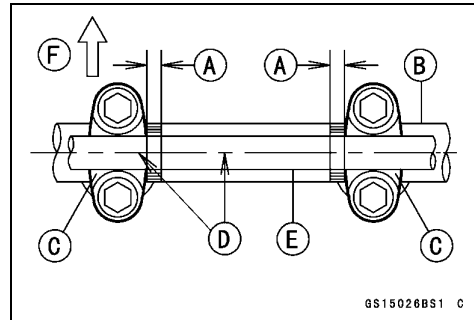

Steering Stem Bearing Lubrication

- Remove the steering stem (see Steering Stem, Stem Bearing Removal in the Steering chapter).
- Using a high-flash point solvent, wash the upper and lower tapered rollers in the cages, and wipe the upper and lower outer races, which are press-fitted into the frame head pipe, clean off grease and dirt.
- Visually check the outer races and the rollers.
- ★ Replace the bearing assemblies if they show wear or damage.
- Pack the upper and lower tapered roller bearings [A] in the cages with grease, and apply a light coat of grease to the upper and lower outer races.
- Install the steering stem, and adjust the steering (see Steering Adjustment).

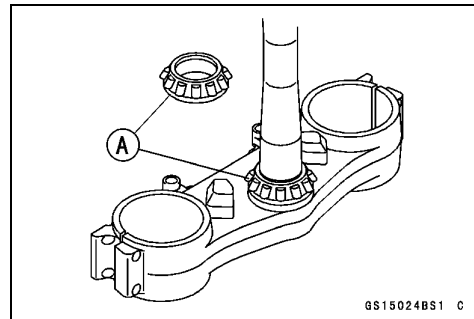

Frame

Frame Inspection

- Clean the frame with steam cleaner.
- Visually inspect the frame and rear frame for cracks, dents, bending, or warp.
- ★ If there is any damage to the frame, replace it.

⚠ WARNING

A repaired frame may fail in use, possibly causing an accident. If the frame is bent, dented, cracked, or warped, replace it.

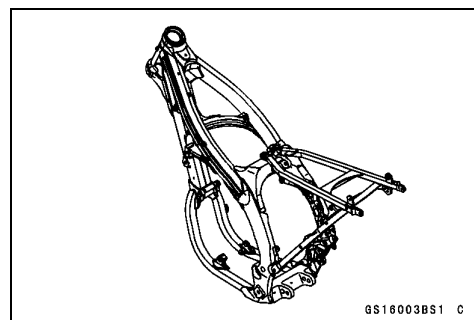

Periodic Maintenance Procedures

Electrical System

Spark Plug Cleaning and Inspection

- Remove:
 - Seat (see Seat Removal in the Frame chapter)
 - Fuel Tank (see Fuel Tank Removal in the Fuel System chapter)
 - Spark Plug Cap
- Clean the plug hole [A], using the compressed air [B].

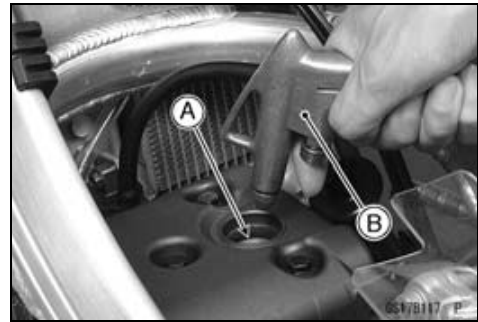

- Remove the spark plug [A], using the spark plug wrench [B].

Special Tool - Spark Plug Wrench: 57001-1262

Owner's Tool - Spark Plug Wrench, 16 mm: 92110-0005

- Clean the spark plug, preferably in a sandblasting device, and then clean off any abrasive particles. The plug may also be cleaned using a high-flash point solvent and a wire brush or other suitable tool.
- ★ If the spark plug electrodes are corroded or damaged, or if the insulator is cracked, replace the plug. Use the standard spark plug.

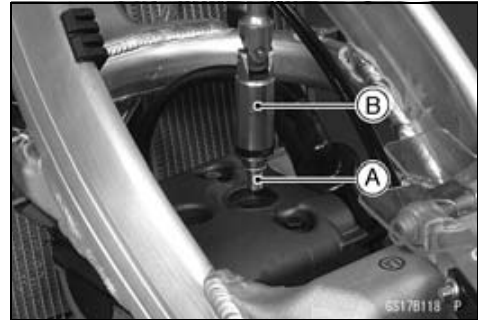

- Measure the gap [A] with a wire-type thickness gauge.
- ★ If the gap is incorrect, carefully bend the side electrode [B] with a suitable tool to obtain the correct gap.

Spark Plug Gap

Standard: 0.8 ~ 0.9 mm (0.03 ~ 0.04 in.)

- Install the spark plug.
- Torque - Spark Plug: 13 N·m (1.3 kgf·m, 113 in·lb)**

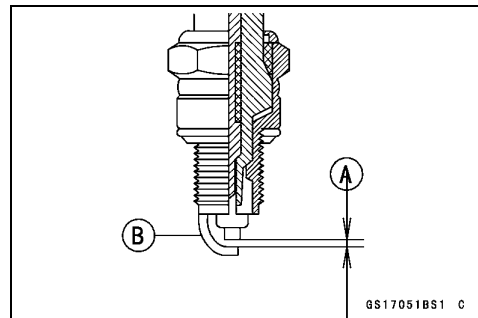

- Fit the plug cap securely.
- Pull the spark plug cap [A] to make sure the installation of the spark plug cap.



Spark Plug Replacement

- Refer to the Spark Plug Cleaning and Inspection.

2-72 PERIODIC MAINTENANCE

Periodic Maintenance Procedures

General Lubrication and Cable Inspection

General Lubrication

- Before lubricating each part, clean off any rusty spots with rust remover and wipe off any grease, oil, dirt, or grime.
- Lubricate the points listed below with indicated lubricant.

NOTE

○Whenever the vehicle has been operated under wet or rainy conditions, or especially after using a high-pressure water spray, perform the general lubrication.

Points: Lubricate with Grease.

Clutch Inner Cable Upper and Lower Ends [A]
Hot Starter Inner Cable Upper End
Throttle Inner Cable Upper End
Brake Lever Pivot Bolt
Clutch Lever Pivot Bolt
Brake Pedal Mounting Bolt

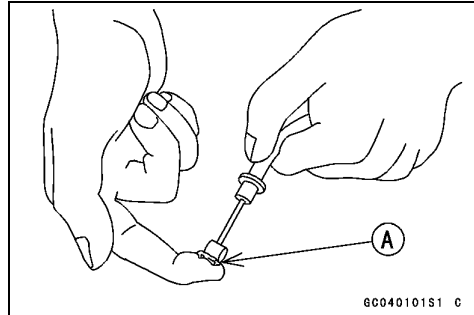

Cables: Lubricate with Rust Inhibitor.

Throttle Inner Cables
Clutch Inner Cable
Hot Starter Inner Cable

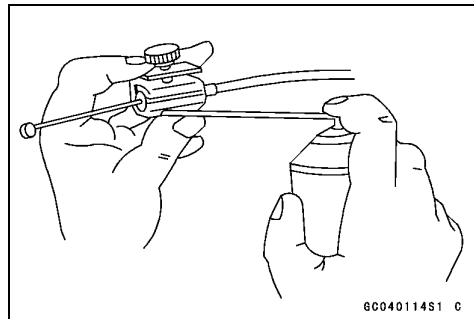

Pivot: Lubricate with Engine Oil.

Hot Starter Lever
Rear Master Cylinder Joint Pin

Periodic Maintenance Procedures

Cable Inspection

- With the cable disconnected at the both ends, the cable should move freely [A] within the cable housing.
- ★ If cable movement is not free after lubricating, if the cable is frayed [B], or if the cable housing is kinked [C], replace the cable.

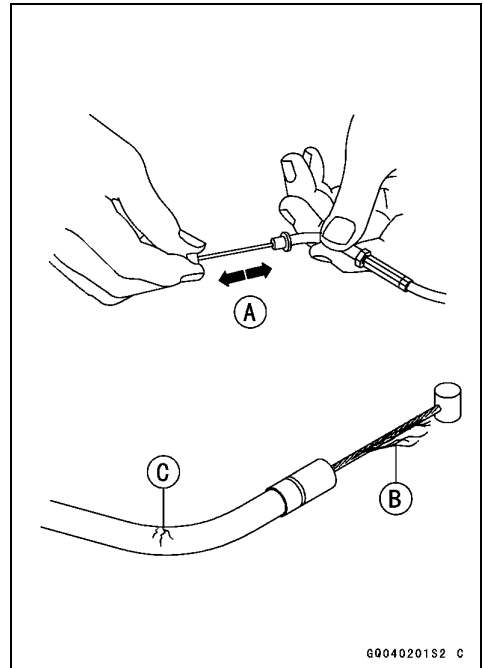

Nut, Bolt, and Fastener Tightness Inspection

Tightness Inspection

- Check the tightness of the bolts and nuts listed here in accordance with the Periodic Maintenance Chart. Also, check to see that each cotter pin is in place and in good condition.

NOTE

○ *For the engine fasteners, check the tightness of them when the engine is cold (at room temperature).*

- ★ If there are loose fasteners, retorque them to the specified torque following the specified tightening sequence. Refer to the Torque and Locking Agent section of the General Information chapter for torque specifications. For each fastener, first loosen it by 1/2 turn, then tighten it.
- ★ If cotter pins are damaged, replace them with new ones.

Nut, Bolt and Fastener to be checked

Wheels:

- Spoke Nipples
- Front Axle Nut
- Front Axle Clamp Bolts
- Rear Axle Nut Cotter Pin
- Rear Axle Nut

Final Drive:

- Chain Adjuster Locknut
- Rear Sprocket Nuts

2-74 PERIODIC MAINTENANCE

Periodic Maintenance Procedures

Brakes:

- Front Master Cylinder Clamp Bolts
- Brake Lever Pivot Nut
- Front Caliper Mounting Bolts
- Brake Pedal Mounting Bolt
- Rear Master Cylinder Push Rod Cotter Pin
- Rear Master Cylinder Mounting Bolts
- Rear Caliper Holder Shaft

Suspension:

- Front Fork Clamp Bolts
- Rear Shock Absorber Mounting Bolts, Nuts
- Swingarm Pivot Shaft Nut

Steering:

- Steering Stem Head Nut
- Handlebar Holder Bolts

Engine:

- Throttle Cable Adjuster Locknuts
- Engine Mounting Bolts, Nuts
- Shift Pedal Bolt
- Muffler Mounting Bolts
- Exhaust Pipe Holder Nuts
- Muffler Pipe Clamp Bolt
- Clutch Cable Adjuster Locknut
- Clutch Lever Pivot Nut

Others:

- Footpeg Cotter Pins
- Rear Frame Mounting Bolts
- Front Fender Bolts

Fuel System

Table of Contents

Exploded View	3-2
Specifications	3-6
Special Tool	3-7
Throttle Grip and Cable	3-8
Throttle Grip (Throttle Cable) Free Play Inspection	3-8
Throttle Grip (Throttle Cable) Free Play Adjustment.....	3-8
Throttle Cable Replacement	3-8
Throttle Cable Lubrication.....	3-9
Throttle Cable Inspection	3-9
Hot Starter Cable Removal	3-10
Hot Starter Cable Installation	3-10
Hot Starter Lever (Hot Starter Cable) Free Play Inspection.....	3-10
Hot Starter Lever (Hot Starter Cable) Free Play Adjustment.....	3-11
Hot Starter Cable Lubrication.....	3-11
Hot Starter Cable Inspection.....	3-11
Carburetor	3-12
Idle Speed Inspection	3-12
Idle Speed Adjustment.....	3-12
Service Fuel Level Inspection	3-12
Service Fuel Level Adjustment	3-13
Carburetor Removal.....	3-14
Carburetor Installation.....	3-16
Fuel System Cleaning.....	3-17
Carburetor Disassembly	3-17
Carburetor Cleaning.....	3-21
Carburetor Inspection	3-21
Carburetor Assembly	3-23
Air Cleaner.....	3-28
Air Cleaner Housing Removal.....	3-28
Air Cleaner Housing Installation.....	3-28
Element Removal.....	3-28
Element Installation.....	3-29
Element Cleaning and Inspection	3-29
Fuel Tank.....	3-30
Fuel Tank Removal	3-30
Fuel Tank Installation	3-30
Fuel Filter Removal.....	3-30
Fuel Filter Installation.....	3-30
Fuel Tank, Filter and Tap Cleaning	3-31
Fuel Tap and Filter Inspection.....	3-31

3-2 FUEL SYSTEM

Exploded View

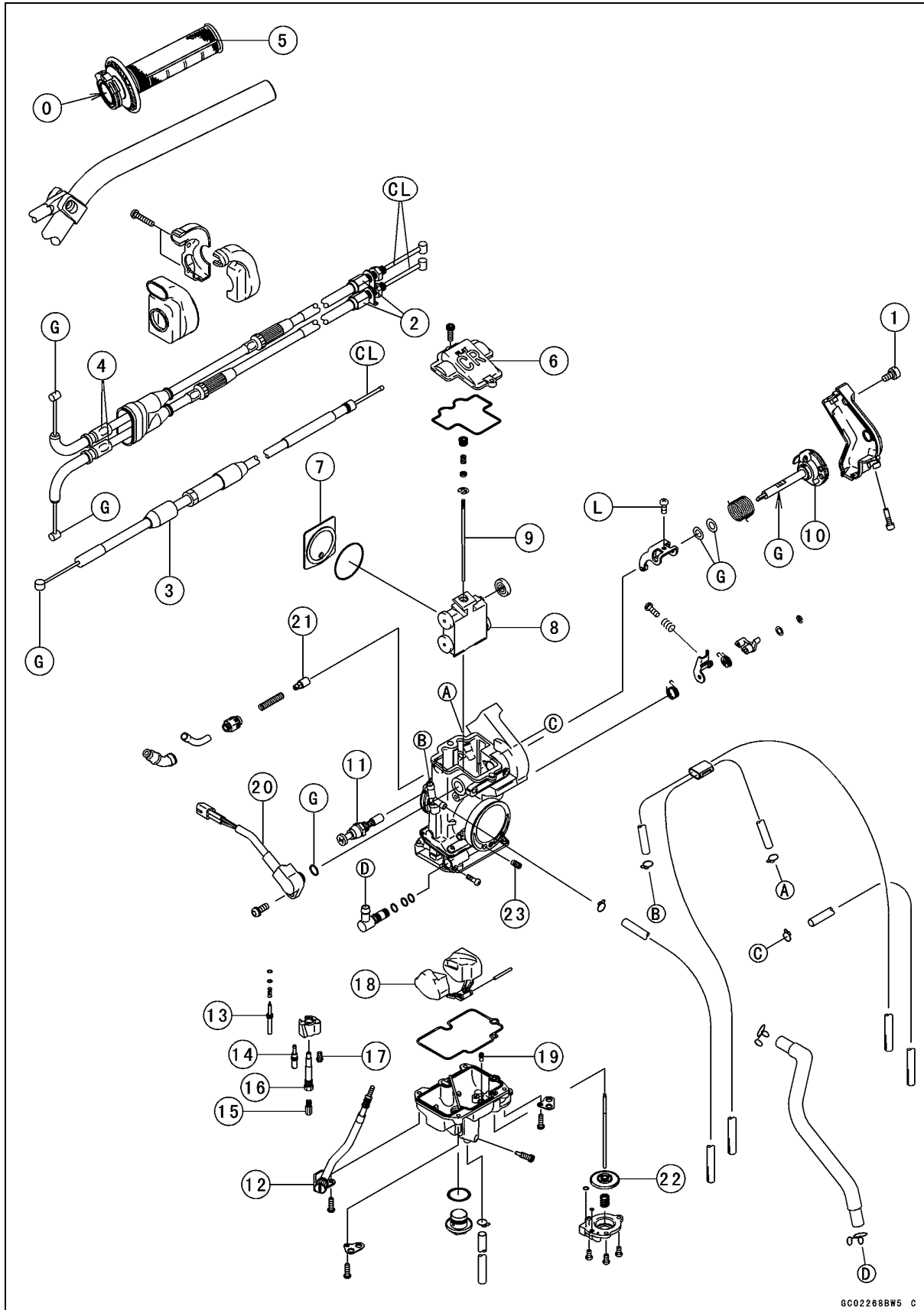

GC02266BWS C

Exploded View

No.	Fastener	Torque			Remarks
		N·m	kgf·m	ft·lb	
1	Throttle Pulley Cover Bolt	3.4	0.35	30 in·lb	
2	Throttle Cable Mounting Bolts	6.9	0.70	61 in·lb	

- 3. Hot Starter Cable
- 4. Throttle Cables
- 5. Throttle Grip
- 6. Carburetor Cap
- 7. Throttle Valve Plate
- 8. Throttle Valve
- 9. Jet Needle
- 10. Throttle Pulley Shaft
- 11. Choke Knob
- 12. Idle Adjusting Screw
- 13. Pilot Air Screw
- 14. Slow Jet
- 15. Main Jet
- 16. Needle Jet
- 17. Starter Jet
- 18. Float
- 19. Leak Jet
- 20. Throttle Sensor
- 21. Hot Starter Plunger
- 22. Acceleration Pump Diaphragm
- 23. Slow Air Jet
- CL: Apply cable lubricant.
- G: Apply grease.
- L: Apply a non-permanent locking agent.
- O: Apply 2-stroke oil.

3-4 FUEL SYSTEM

Exploded View

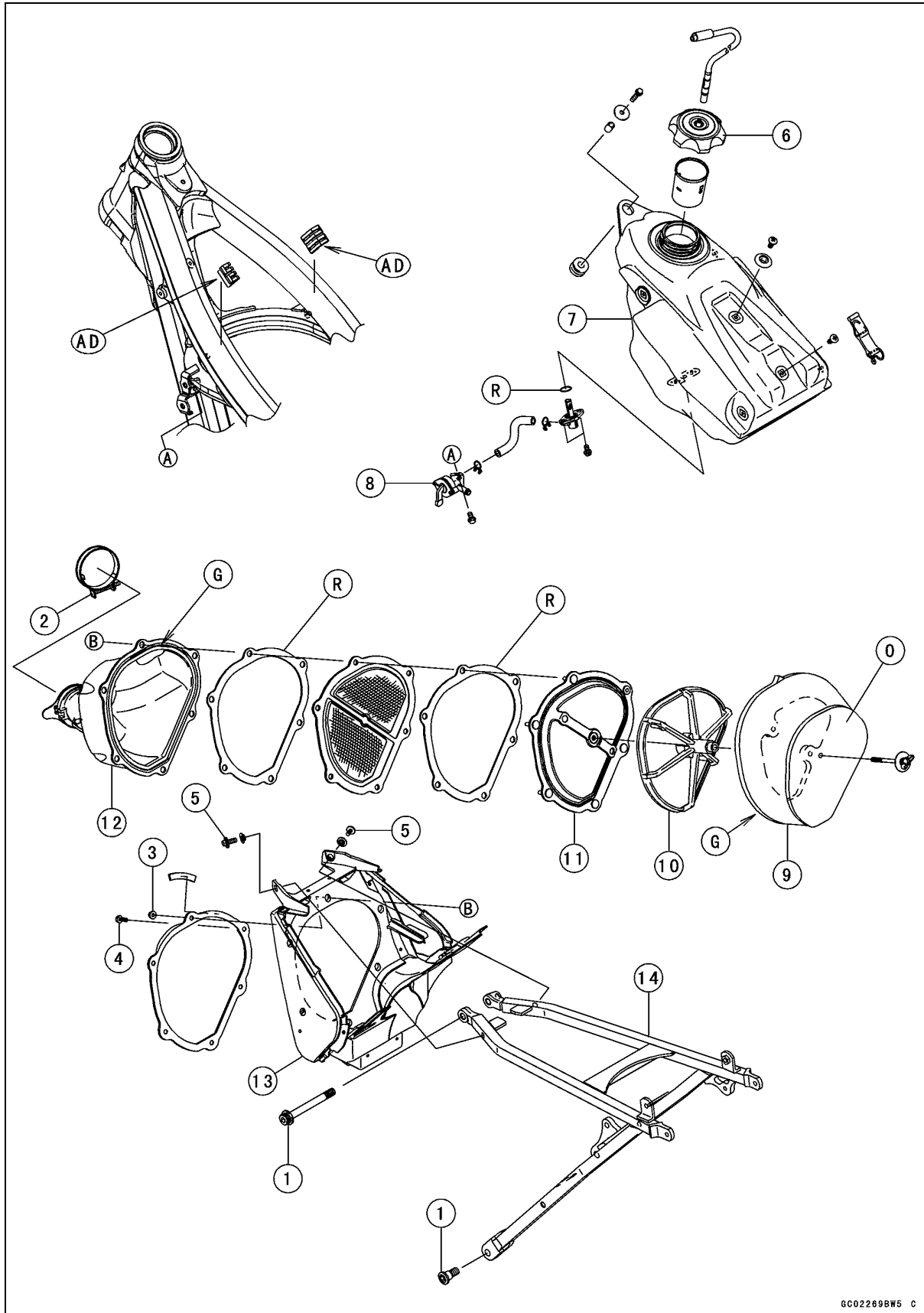

GC02269BWS C

Exploded View

No.	Fastener	Torque			Remarks
		N·m	kgf·m	ft·lb	
1	Rear Frame Mounting Bolts	34	3.5	25	
2	Air Cleaner Duct Clamp Screw	2.0	0.20	17 in·lb	
3	Air Cleaner Duct Mounting Nuts	3.0	0.31	27 in·lb	
4	Air Cleaner Duct Mounting Bolt	3.0	0.31	27 in·lb	
5	Air Cleaner Housing Bolts	9.8	1.0	87 in·lb	

- 6. Fuel Tank Cap
 - 7. Fuel Tank
 - 8. Fuel Tap
 - 9. Element
 - 10. Frame
 - 11. Holder
 - 12. Air Cleaner Duct
 - 13. Air Cleaner Housing
 - 14. Rear Frame
- AD: Apply adhesive cement.
 G: Apply grease.
 O: High-quality foam air filter oil.
 R: Replacement Parts

3-6 FUEL SYSTEM

Specifications

Item	Standard
Throttle Grip and Cable	
Throttle Grip Free Play	2 ~ 3 mm (0.08 ~ 0.12 in.)
Hot Starter Lever Free Play	0.5 ~ 1.0 mm (0.02 ~ 0.04 in.)
Carburetor	
Make/Type	KEIHIN FCR40
Starter Jet	#72
Leak Jet	#70
Main Jet	#175
Throttle Valve Cutaway	CA1.5
Jet Needle	NCVR
Jet Needle Clip Position	4th groove from the top
Slow Jet	#42, (EUR) 40 (KX450D6F)
Slow Air Jet	#100
Pilot Air Screw (turns out)	2 1-1/2, (EUR) 1 (KX450D7F) (Reference)
Service Fuel Level (below the bottom edge of the carb. body)	6.5 ±1 mm (0.256 ±0.039 in.)
Float Height	8 ±1 mm (0.315 ±0.039 in.)
Air Cleaner	
Air Cleaner Element Oil	High quality form air filter oil

(EUR):Europe Model

Special Tool

**Fuel Level Gauge, M18 × 1.0:
57001-122**

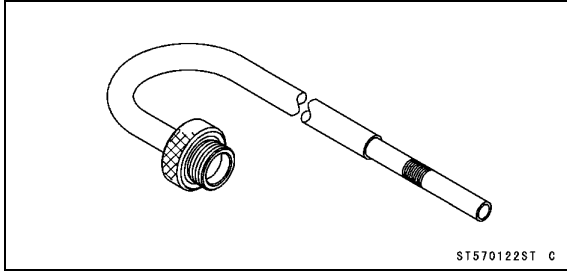

3-8 FUEL SYSTEM

Throttle Grip and Cable

If the throttle grip has excessive free play due to cable stretch or misadjustment, there will be a delay in throttle response. Also, the throttle valve may not open fully at full throttle. On the other hand, if the throttle grip has no play, the throttle will be hard to control, and the idle speed will be erratic. Check the throttle grip play periodically in accordance with the Periodic Maintenance Chart, and adjust the play if necessary.

The throttle cable routing is shown in Cable, Wire, and Hose Routing Section in the Appendix chapter.

Throttle Grip (Throttle Cable) Free Play Inspection

- Refer to the Throttle Grip Free Play Inspection in the Periodic Maintenance chapter.

Throttle Grip (Throttle Cable) Free Play Adjustment

- Refer to the Throttle Grip Free Play Adjustment in the Periodic Maintenance chapter.

Throttle Cable Replacement

- Remove the front master cylinder [A] (see Front Master Cylinder Removal in the Brakes chapter).
- Slide out the dust cover [B] and cable housing dust cover [C].

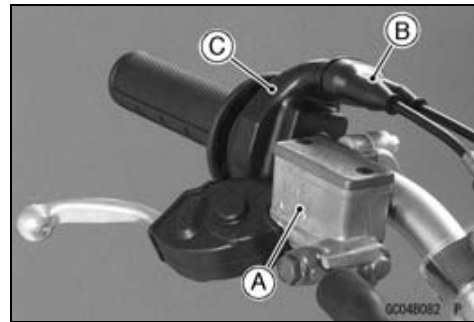

- Unscrew the screws [A].
- Separate the throttle cable housing [B].

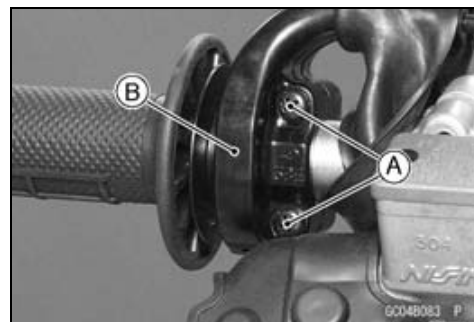

- Free the tips [A] from the grip [B].



Throttle Grip and Cable

- Remove the rear frame assy (see Rear Frame Removal in the Frame chapter).
- Remove the carburetor.
- Unscrew the bolt [A].
- Remove the throttle pulley cover [B].

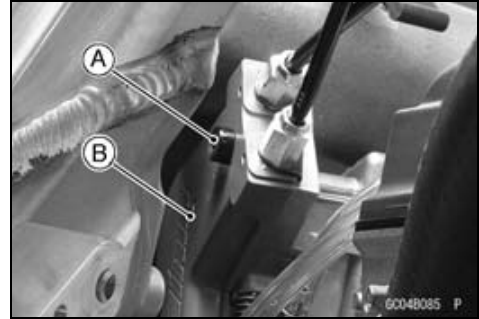

- Loosen the mounting bolts [A].
- Remove the cables [B] from the carburetor.
- Free the tips [C] from the pulley.
- Pull out the cables from the frame.

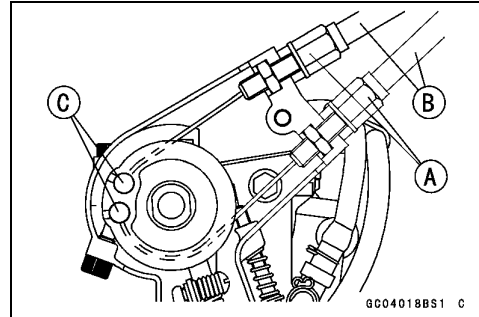

- Lubricate the cable.
- Apply grease to the tips of the cables.
- Install the throttle cable tips [A].
- Install the mounting bolts [B] to the holder as shown.
- Install the throttle pulley cover.

Torque - Throttle Cable Mounting Bolts: 6.9 N·m (0.70 kgf·m, 61 in·lb)

Throttle Pulley Cover Bolt: 3.4 N·m (0.35 kgf·m, 30 in·lb)

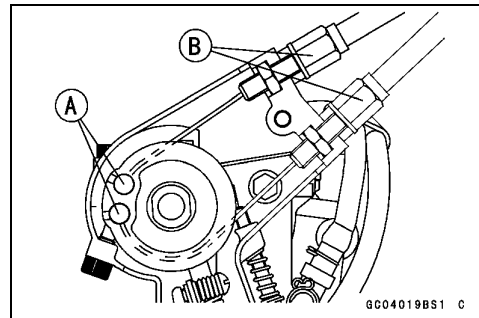

- Install the throttle cable in accordance with the Cable, Wire, and Hose Routing section in the Appendix chapter.
- After the installation, adjust each cable properly.

⚠ WARNING

Operation with an incorrectly routed or improperly adjusted cable could result in an unsafe riding condition.

Throttle Cable Lubrication

- Whenever the throttle cable is removed or in accordance with the Periodic Maintenance Chart, lubricate these cables (see Lubrication in the Periodic Maintenance chapter).
- Apply a thin coating of grease to the cable upper end.
- Use a commercially available pressure cable lubricator to lubricate these cables.

Throttle Cable Inspection

- Refer to the Cable Inspection in the Periodic Maintenance chapter.

3-10 FUEL SYSTEM

Throttle Grip and Cable

Hot Starter Cable Removal

- Remove:
 - Dust Cover [A] (Slide out)
 - Locknut [B] (Loosen)
 - Turn in the adjuster [C] fully.
 - Remove the cable end [D] from the hot starter lever [E].
-
- Remove:
 - Carburetor (see Carburetor Removal)
 - Unscrew the plunger cap bolt [A] and remove the cable end.
-
- Disassemble the cable end from the plunger [A].
 - Spring [B]
 - Plunger Cap Assy [C]
-
- Remove:
 - Left Radiator Shroud
 - Clamps [A] (Open)
 - Hot Starter Cable [B]

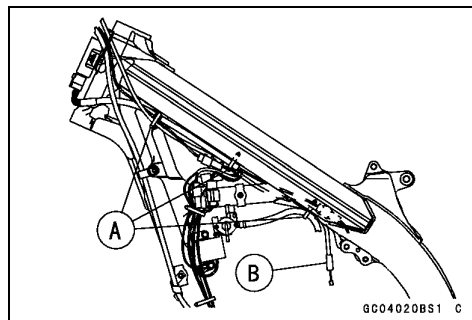
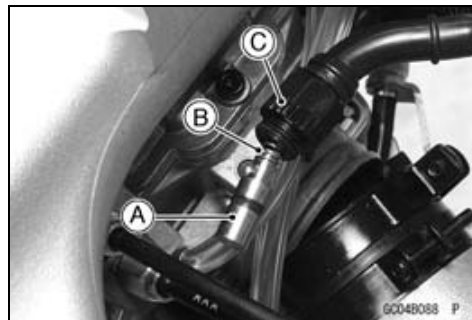
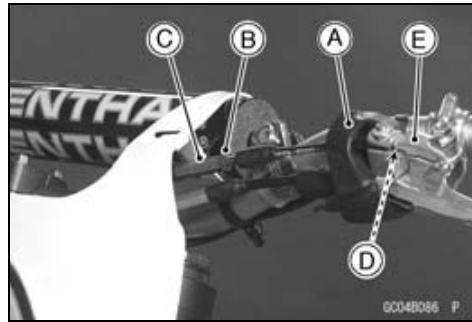

Hot Starter Cable Installation

- Install the hot starter cable in accordance with the Cable, Wire and Hose Routing section in the appendix chapter.
- After the installation, adjust the cable properly.

▲ WARNING

Operation with an incorrectly routed or improperly adjusted cable could result in an unsafe riding condition.

Hot Starter Lever (Hot Starter Cable) Free Play Inspection

- Refer to the Hot Starter Lever (Hot Starter Cable) Free Play Inspection in the Periodic Maintenance chapter.

Throttle Grip and Cable

Hot Starter Lever (Hot Starter Cable) Free Play Adjustment

- Refer to the Hot Starter Lever (Hot Starter Cable) Free Play Inspection in the Periodic Maintenance chapter.

Hot Starter Cable Lubrication

- Whenever the hot starter cable is removed or in accordance with the Periodic Maintenance Chart, lubricate the these cable (see General Lubrication and Cable Inspection in the Periodic Maintenance chapter).

Hot Starter Cable Inspection

- Refer to the General Lubrication and Cable Inspection in the Periodic Maintenance chapter.

3-12 FUEL SYSTEM

Carburetor

Since the carburetor regulates and mixes the fuel and air going to the engine, there are two general types of carburetor trouble: too rich a mixture (too much fuel), and too lean a mixture (too little fuel). Such trouble can be caused by dirt, wear, maladjustment, or improper fuel level in the float chamber. A dirty or damaged air cleaner can also alter the fuel to air ratio.

Idle Speed Inspection

- Refer to the Idle Speed Inspection in the Periodic Maintenance chapter.

Idle Speed Adjustment

- Refer to the Idle Speed Adjustment in the Periodic Maintenance chapter.

Service Fuel Level Inspection

▲ WARNING

Gasoline is extremely flammable and can be explosive under certain conditions. Always stop the engine and do not smoke. Make sure the area is well ventilated and free from any source of flame or sparks; this includes any appliance with a pilot light.

- Turn the fuel tap to the OFF position.
- Remove the fuel tank.
- Remove the carburetor, and hold it in true vertical position on a stand. The fuel hose and carburetor cable do not have to be removed to inspect the fuel level.
- Put the fuel tank on a bench, and connect the fuel tap to the carburetor using a suitable hose.
- Remove the drain plug from the bottom of the float bowl, and screw a fuel level gauge [A] into the plug hole.

Special Tools - Fuel Level Gauge: 57001-122

- Hold the gauge vertically against the side of the carburetor body so that the "zero" line [B] is several millimeters higher than the bottom edge [C] of the carburetor body.
- Turn the fuel tap to the ON position to feed fuel to the carburetor.
- Wait until the fuel level in the gauge settles.
- Keeping the gauge vertical, slowly lower the gauge until the "zero" line is even with the bottom edge of the carburetor body.

NOTE

○ Do not lower the "zero" line below the bottom edge of the carburetor body. If the gauge is lowered and then raised again, the fuel level measure shows somewhat higher than the actual fuel level. If the gauge is lowered too far, dump the fuel out of it into a suitable container and start the procedure over again.

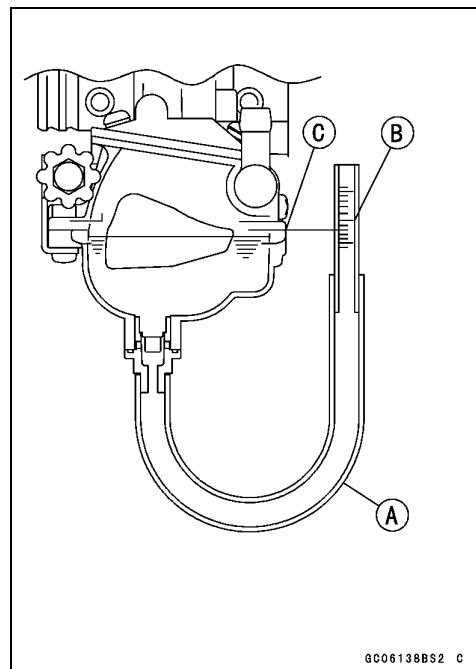

GC06138B52 C

Carburetor

- Read the fuel level [D] in the gauge and compare it to the specification.

Service Fuel Level (below the bottom edge of the carb. body)

Standard: 6.5 ±1 mm (0.256 ±0.039 in.)

- ★ If the fuel level is incorrect, adjust it.
- Turn the fuel tap to the OFF position and remove the fuel level gauge.
- Install the drain plug on the bottom of the float bowl.

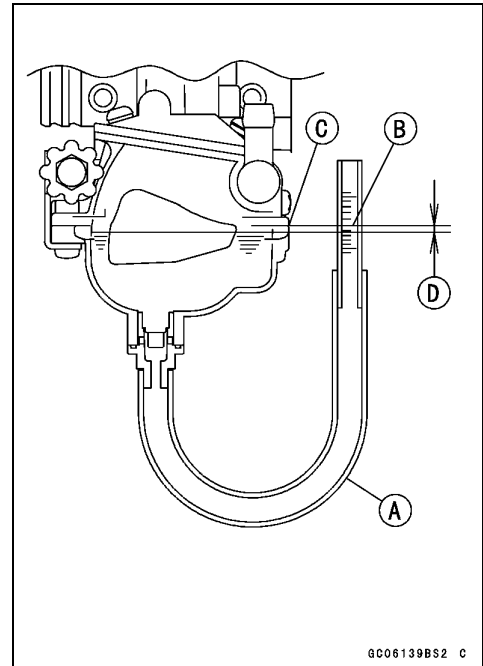

Service Fuel Level Adjustment

⚠ WARNING

Gasoline is extremely flammable and can be explosive under certain conditions. Always stop the engine and do not smoke. Make sure the area is well-ventilated and free from any source of flame or sparks; this includes any appliance with a pilot light.

- Remove the carburetor, and drain the fuel into a suitable container.
- Remove the float bowl (see Carburetor Disassembly).
- Drive out the pivot pin [A] and remove the float [B] with valve needle [C].

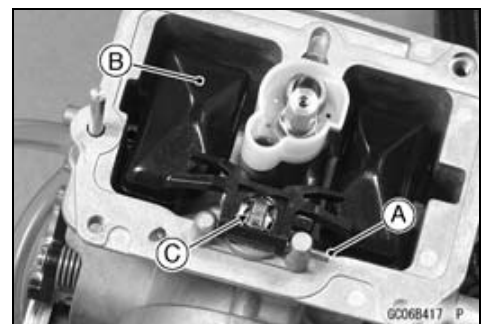

3-14 FUEL SYSTEM

Carburetor

- Bend the tang [A] on the float arm very slightly to change the float height. Increasing the float height lowers the fuel level and decreasing the float height raises the fuel level.

Float Height

Standard: 8 ± 1 mm (0.315 ± 0.039 in.)

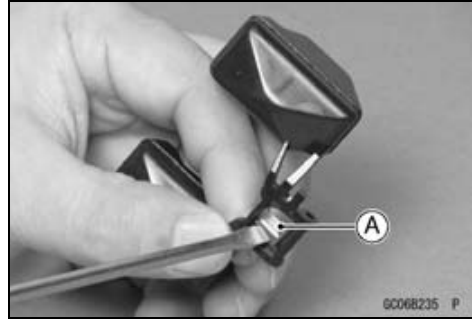

NOTE

- Float height [A] is the distance from the float bowl mating surface [B] of the carburetor body (with the gasket removed) to the top of the float [C]. Measure the height with the carburetor upside down.
- Do not push the needle rod [D] in during the float height measurement.

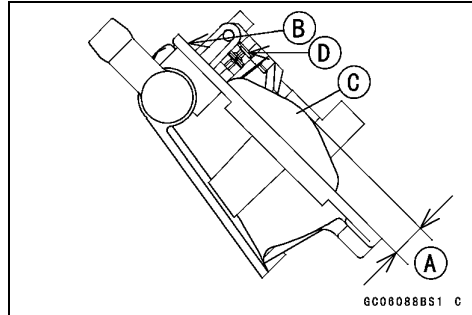

- Assemble the carburetor, and recheck the fuel level.
- ★ If the fuel level cannot be adjusted by this method, the float or the float valve is damaged.

Carburetor Removal

⚠ WARNING

Gasoline is extremely flammable and can be explosive under certain conditions. Always stop the engine and do not smoke. Make sure the area is well-ventilated and free from any source of flame or sparks; this includes any appliance with a pilot light.

- Turn the fuel tap lever [A] to the OFF position.
- Slide off the clamp [B] and pull the fuel hose [C] off the tap.

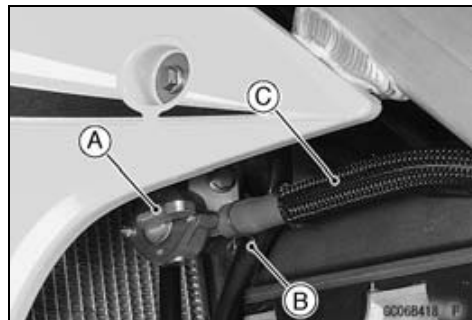

Carburetor

- Remove the fuel tank (see Fuel Tank Removal).
- Disconnect the throttle sensor connector [A].



- Loosen the clamp screws [A] of both carburetor holder and air cleaner duct fully.
- Remove:
 - Engine Mounting Bracket Bolts [B]
 - Engine Mounting Bracket [C]

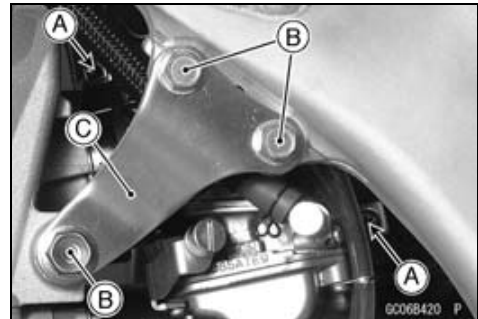

- Remove:
 - Seat (see Seat Removal in the Frame chapter)
 - Side Covers (see Side Cover Removal in the Frame chapter)
 - Muffler (see Muffler Removal in the Engine Top End chapter)
 - Rear Frame Bolts [A]
- Pull out the rear frame [B] with the air cleaner housing and remove the carburetor.



- Unscrew the hot starter plunger cap bolt [A].
- Remove the hot starter plunger.



- Unscrew the throttle pulley cover bolt [A].
- Remove the throttle pulley cover [B].

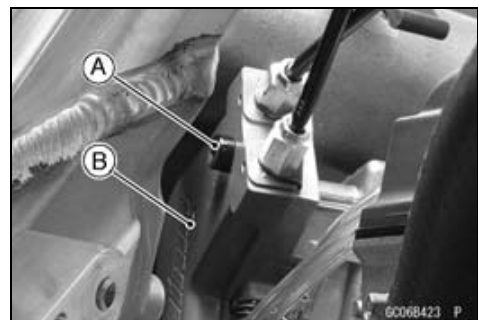

3-16 FUEL SYSTEM

Carburetor

- Loosen the throttle cable mounting bolts [A].
- Pull out the end of the throttle cables [B].
- Free the tips [C].
- Remove the carburetor to the right side of the frame.
- Drain the fuel from the float bowl by removing the drain plug. After draining, install the drain plug securely.
- After removing the carburetor, push a clean, lint-free towel into the carburetor holder and the air cleaner duct to keep dirt or other foreign material from entering.

⚠ WARNING

If dirt or dust is allowed to pass through into the carburetor, the throttle may become stuck, possibly causing an accident.

CAUTION

If dirt gets through into the engine, excessive engine wear and possibly engine damage will occur.

Carburetor Installation

- Install:
 - Throttle Cables (see Throttle Cable Replacement)
 - Hot Starter Plunger (see Hot Starter Cable Installation)
- Tighten:
 - Torque - Throttle Pulley Cover Bolt: 3.4 N·m (0.35 kgf·m, 30 in·lb)**
 - Throttle Cable Mounting Bolts: 6.9 N·m (0.70 kgf·m, 61 in·lb)**
- When installing the carburetor into the carburetor holder, fit the projection [A] of the carburetor with the groove [B] on the holder.
- Fit the claw [A] of the clamp onto the groove [B] of the inlet duct.
- Tighten the clamps securely.
 - Torque - Air Cleaner Duct Clamp Screw : 2.0 N·m (0.20 kgf·m, 17 in·lb)**
- Route the air vent and overflow hoses properly (see Cable, Wire and Hose Routing Section in the Appendix chapter).

CAUTION

Always keep the hoses free of obstruction, and make sure they do not get pinched by the chain or shock absorber.

- Connect the throttle sensor connector.
- After installing the carburetor, do the following.
 - Turn the fuel tap to the ON position, and check for fuel leakage from the carburetor.

⚠ WARNING

Fuel spilled from the carburetor is hazardous.

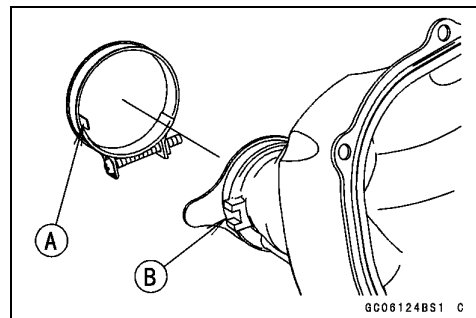
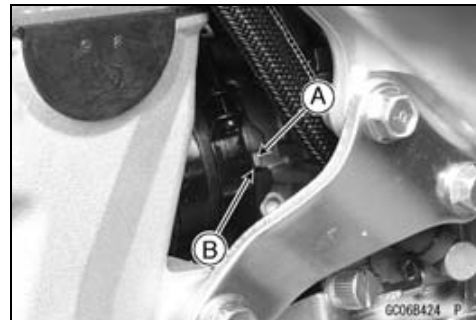
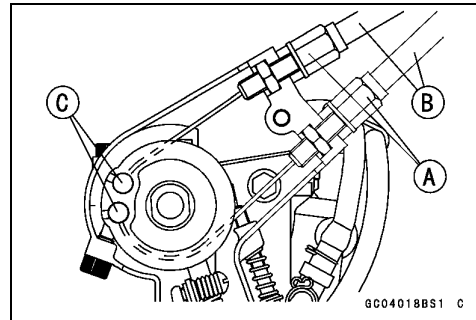

Carburetor

○ Adjust the following items if necessary:

- Throttle Cable (see Throttle Grip (Throttle Cable) Free Play Adjustment in the Periodic Maintenance chapter)
- Idle Speed (see Idle Speed Adjustment in the Periodic Maintenance chapter)

Fuel System Cleaning

- Refer to the Fuel System Cleaning in the Periodic Maintenance chapter.

Carburetor Disassembly

- Remove the carburetor.
- Remove all vent hoses [A] and fuel hose [B].

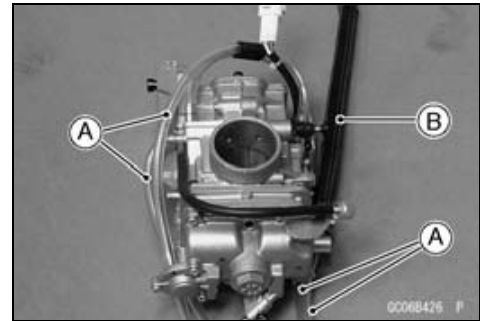

- Unscrew the screw [A].
- Pull out the fuel hose fitting [B].

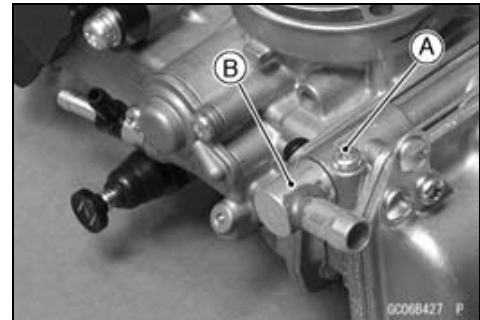

- Unscrew the carburetor cap bolts [A].
- Remove the carburetor cap [B].

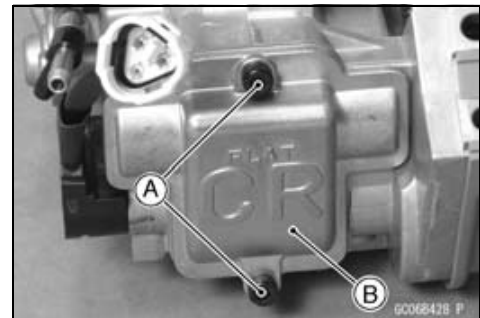

- Unscrew the throttle valve link screw [A].
- Pull out the throttle valve assembly [B].

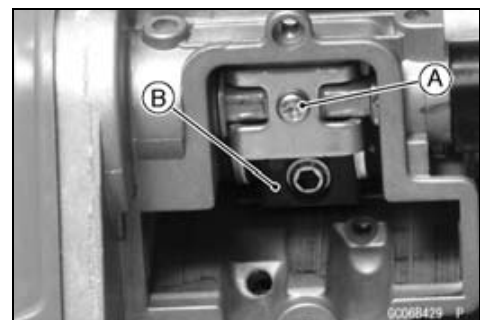

3-18 FUEL SYSTEM

Carburetor

- Disassemble the throttle valve assembly; jet needle holder [A] (unscrew), spring [B], retainer [C], jet needle with circlip [D], O-ring with throttle valve plate [E], and throttle valve [F].

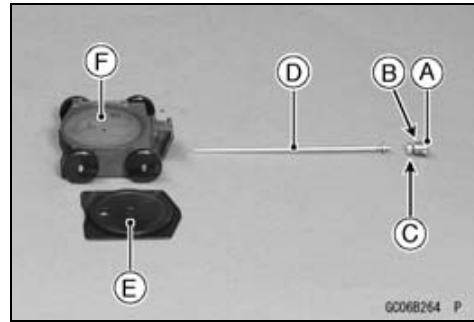

- Remove the choke knob/starter plunger assembly [A] from the carburetor.

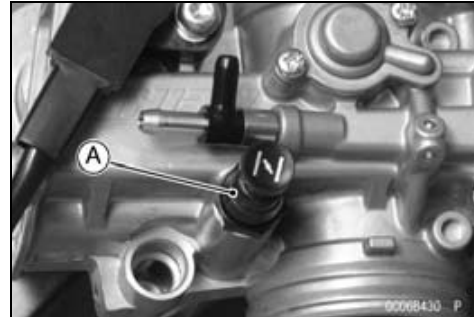

- Remove the throttle pulley shaft [A] with the spring [B], steel washer [C], plastic washer [D], and throttle valve link [E].

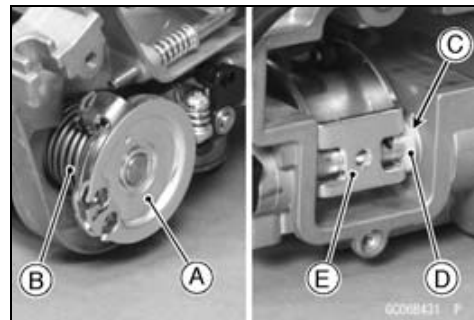

- Turn the throttle pulley shaft [A] clockwise while holding down the acceleration pump lever [B] and clear the idle stop screw [C] to the stopper [D] of the pulley.

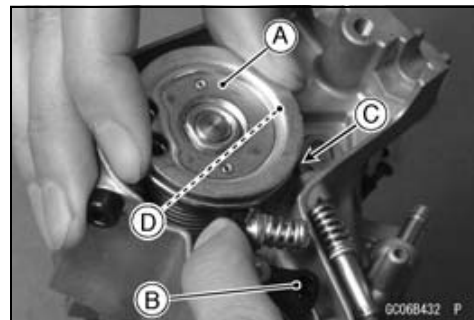

- Turn in the pilot air screw [A] fully but not tightly and count the number of turns.
- Record this number as the manufacture-set number of turns out to put back to the original position.
- Unscrew the pilot air screw.



Carburetor

- Unscrew the screws [A].
- Remove the acceleration pump cover [B] from the carburetor.

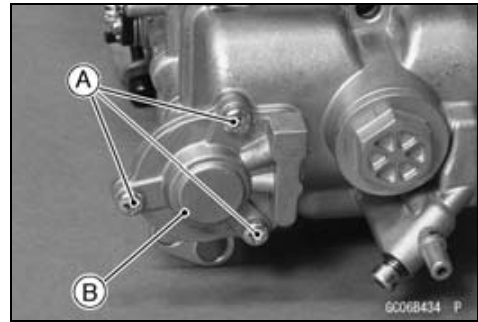

- Remove the spring [A], diaphragm [B], and the O-rings [C].

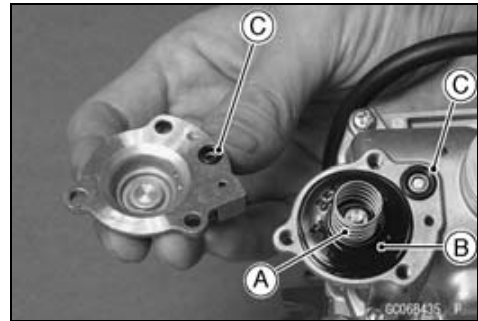

- Remove the following parts from the carburetor body.

- [A] Idle Adjusting Screw
- [B] Screws
- [C] Clamps
- [D] Float Bowl
- [E] Leak Jet
- [F] O-ring
- [G] Pin
- [H] Float
- [I] Main Jet
- [J] Needle Jet
- [K] Starter Jet
- [L] Pilot Jet
- [M] Pilot Air Jet

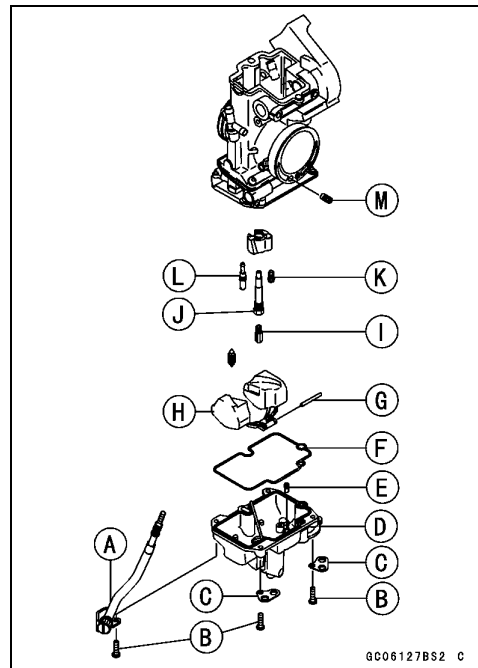

- Pull out the push rod [A] of the acceleration pump.



3-20 FUEL SYSTEM

Carburetor

- Unscrew the leak jet [A].



- Remove:
 - E-clip [A]
 - Washer [B]
- Pull out the acceleration pump lever assembly [C] as a set.



- Remove the throttle sensor mounting bolt [A].
- Before removing the throttle sensor [B], mark [C] the carburetor body and sensor so that it can be installed later in the same position.

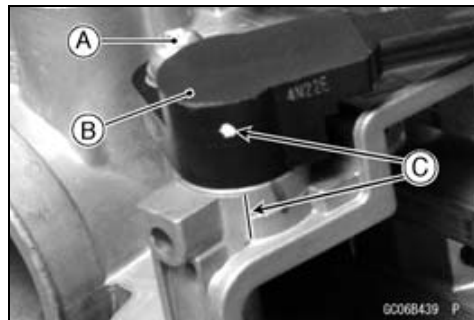

Carburetor

Carburetor Cleaning

⚠ WARNING

Clean the carburetor in a well-ventilated area, and take care that there is no spark or flame anywhere near the working area; this includes any appliance with a pilot light. Because of the danger of highly flammable liquids, do not use gasoline or low-flash point solvent to clean the carburetor.

- Make sure the fuel tap is in the OFF position.
- Remove the carburetor (see Carburetor Removal).
- Drain the fuel in the carburetor.
- Disassemble the carburetor (see Carburetor Disassembly).

CAUTION

Do not use compressed air on an assembled carburetor, the float may be deformed by the pressure. Remove as many rubber or plastic parts from the carburetor as possible before cleaning the carburetor with a cleaning solution. This will prevent damage or deterioration of the parts. Do not use a strong carburetor cleaning solution which could attack the plastic parts; instead, use a mild high-flash point cleaning solution safe for plastic parts. Do not use wire or any other hard instrument to clean carburetor parts, especially jets, as they may be damaged.

- Immerse all the metal parts in a carburetor cleaning solution.
- Rinse the parts in water.
- After the parts are cleaned, dry them with compressed air.
- Blow through the air and fuel passages with compressed air [A].
- Assemble the carburetor, and install it on the motorcycle.

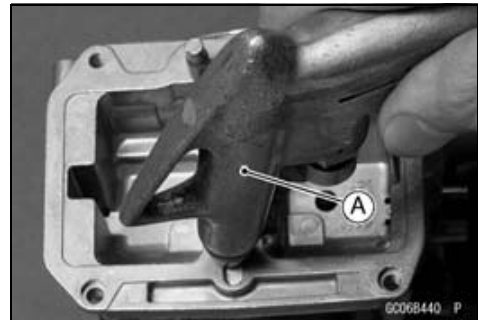

Carburetor Inspection

⚠ WARNING

Gasoline is extremely flammable and can be explosive under certain conditions. Always stop the engine and do not smoke. Make sure the area is well-ventilated and free from any source of flame or sparks; this includes any appliance with a pilot light.

3-22 FUEL SYSTEM

Carburetor

- Remove the carburetor (see Carburetor Removal).
- Before disassembling the carburetor, check the fuel level (see Service Fuel Level Inspection).
- ★ If the fuel level is incorrect, inspect the rest of the carburetor before correcting it.
- Turn the throttle pulley to check that the throttle valve [A] moves smoothly and returns by spring pressure.
- ★ If the throttle valve does not move smoothly. Replace the throttle valve or pulley spring.
- Disassemble the carburetor (see Carburetor Disassembly).
- Clean the carburetor (see Carburetor Cleaning).

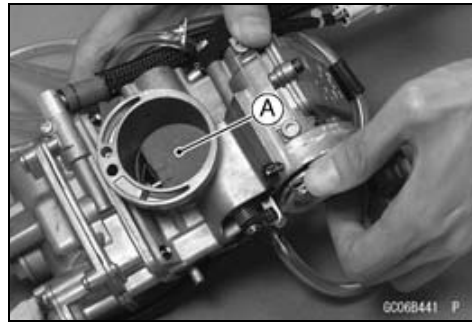

- Check the tapered portion [A] of the pilot air screw [B] for wear or damage.
- ★ If the pilot air screw is worn or damaged on the tapered portion, it will prevent the engine from idling smoothly. Replace it.

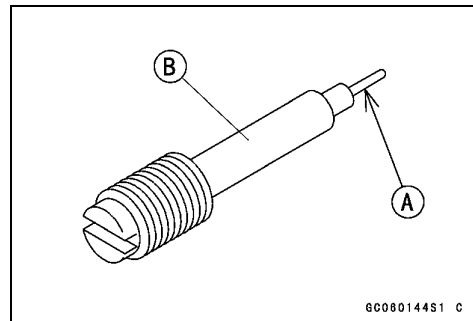

- Remove the float valve needle.
- Check the plastic tip [A] of the float valve needle [B] for wear.
- ★ If the needle is worn as shown right [C], replace the valve needle.
- Push the rod [D] in the valve needle, then release it.
- ★ If the rod does not come out fully by spring tension, replace the valve needle.
Push and release [E]

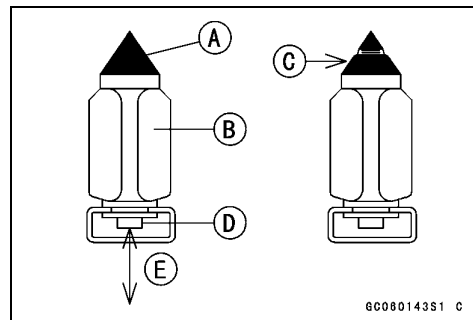

- Remove the starter jet.
- Check the slow jet for any damage.
- ★ If the slow jet is damaged, replace it with a new one.
- Remove the throttle valve and jet needle.
- Inspect the outside of the throttle valve and plate for scratches and abnormal wear.
- ★ If it is badly scratched or worn, replace the throttle valve or plate.
- Inspect the inside of the carburetor body for these same faults.
- ★ If it is badly scratched or worn, replace the entire carburetor.
- Check the jet needle for wear.
- For the throttle sensor inspection, see the Electrical System chapter.
- ★ A worn jet needle should be replaced.
- Clean the fuel and air passages with a high-flash point solvent and compressed air.

Carburetor

Carburetor Assembly

- Clean the disassembly parts before assembling.
- Clean the fuel and air passages with a high-flash point solvent and compressed air [A].



- Set up the acceleration pump lever assembly as shown.
 - Acceleration pump lever [A]
 - Spring [B]
 - Push Rod Holder [C]
 - Adjusting Screw with Spring [D]
- Fit the spring end on the stopper [E] of the push rod holder.

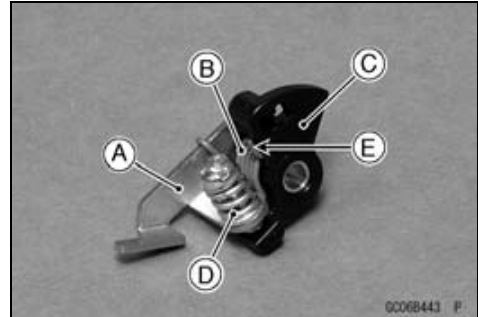

- Install the return spring [A] to the acceleration pump lever [B].

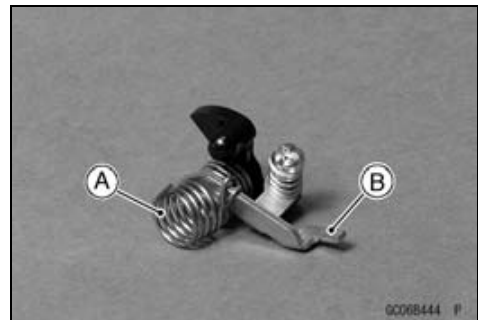

- Install the acceleration pump lever assembly to the carburetor body.
- Fit the end [B] of the return spring into the recess [A] on the carburetor body.

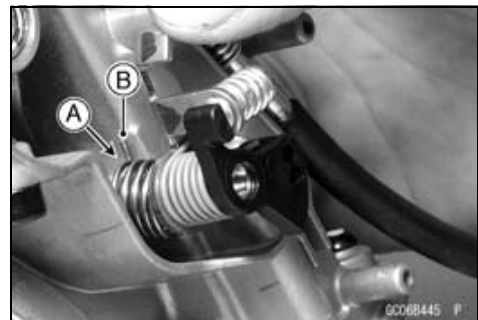

- Install:
 - Washer [A]
 - E-clip [B]

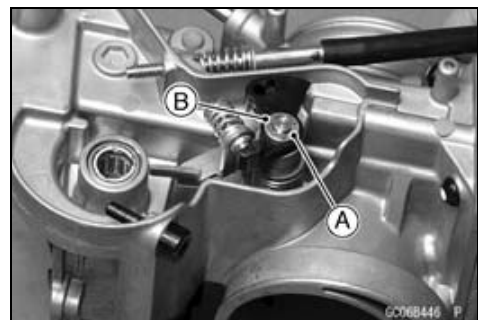

3-24 FUEL SYSTEM

Carburetor

- Apply thin coat silicone grease to the shaft.
- Fit the hook [A] of the return spring onto the stopper [B] of the throttle cable pulley.

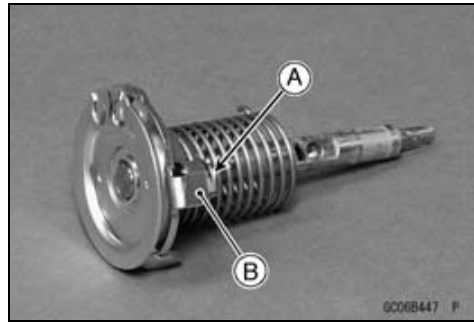

- Insert the throttle cable pulley shaft [A] and install the steel washer [B], nylon washer [C] and valve link [D].

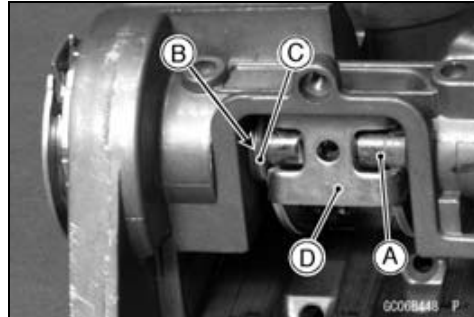

- Fit the end [A] of the return spring into the recess [B] of the carburetor body.

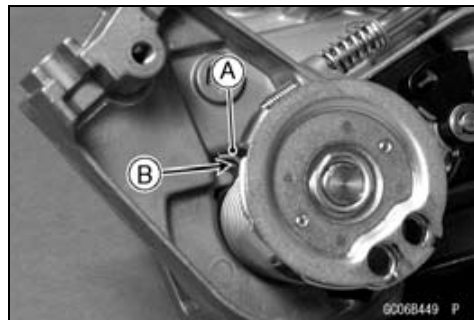

- Turn the pulley counterclockwise [A] while holding down the acceleration pump lever [B] and clear the stopper [C] of the pulley from the throttle stop screw head [D].

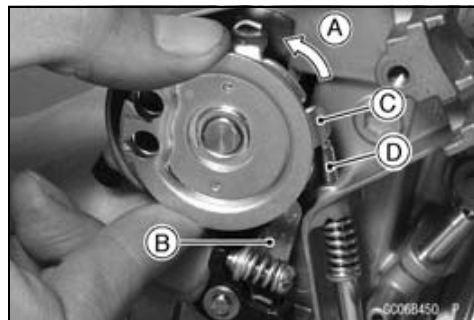

- Install the push rod [A] into the push rod holder [B].

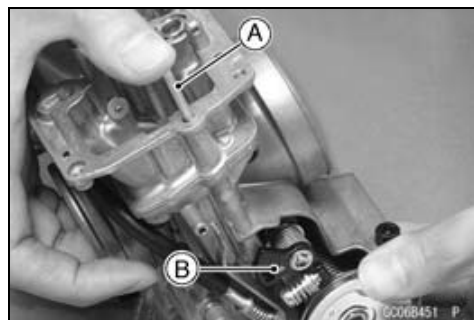

Carburetor

- Assembly:
 - Throttle Valve [A]
 - Jet Needle [B]
 - Circlip [C]
 - Retainer [D]
 - Spring [E]
 - Jet Needle Holder [F]
 - O-ring [G]
 - Throttle Valve Plate [H]

○ Assemble the valve plate so that the hole side downward [I].

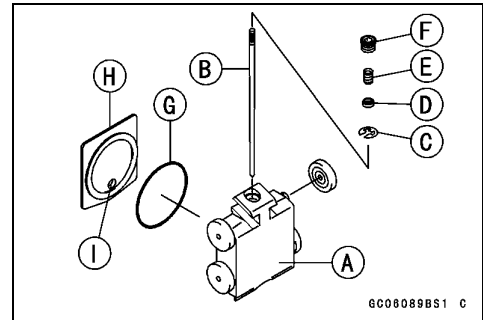

- Apply a non-permanent locking agent to the link screw.
- Insert the throttle valve assembly.
- Insert the link rollers [A] on the throttle link into the slits [B] of the throttle valve.
- Tighten the screw.

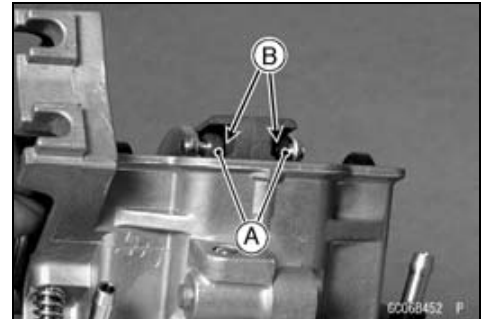

- Apply a grease to the O-ring [A].
- Fit the stopper [B] of the throttle sensor onto the projection [C] on the throttle cable pulley shaft.
- Install the throttle sensor so that the marks aligns and check it position (see Throttle Sensor Inspection in the Electrical System chapter).

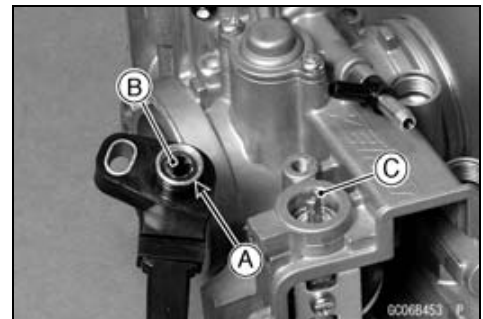

- Install:
 - O-ring [A]
 - Carburetor Cap [B]
 - Bolts (tighten)

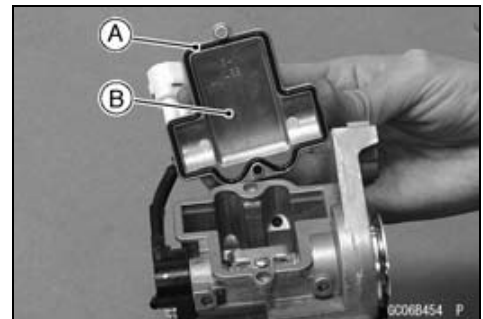

- Install:
 - Starter Jet [A]
 - Pilot Jet [B]
 - Baffle Plate [C]
 - Needle Jet [D]
 - Main Jet [E]

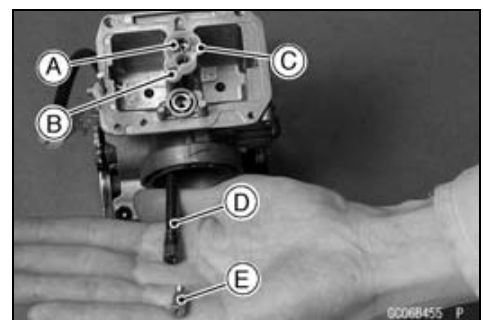

3-26 FUEL SYSTEM

Carburetor

- Replace the O-ring with new one.
- Install:
 - Pilot Air Screw [A]
 - Spring [B]
 - Washer [C]
 - O-ring [D]
- Turn in the pilot air screw fully but not tightly, and then back it out the counted number of turns (see Carburetor Disassembly).

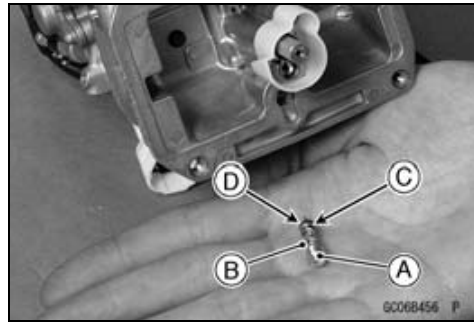

- Hang the float valve [A] on the tang [B] of the float [C].
- Fit the float valve into the valve seat.
- Insert the pin [D].

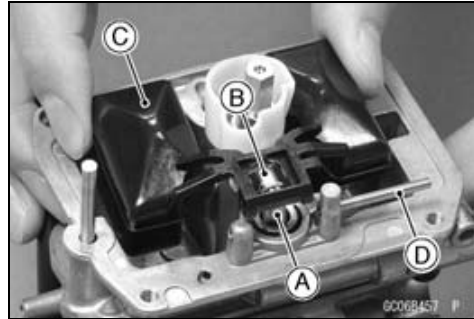

- Install:
 - Leak Jet [A]
- Replace the O-ring with new one.
- Fit the O-ring [B] onto the groove of the float chamber.

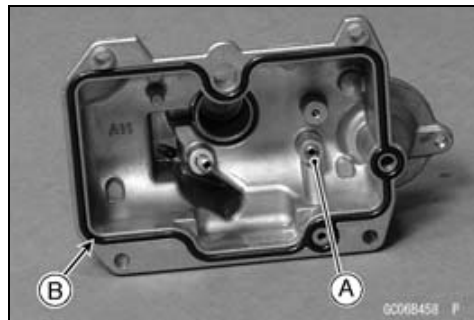

- Install:
 - Float Bowl
- Tighten the screws with hose clamps [A] and cable holder [B] as shown.

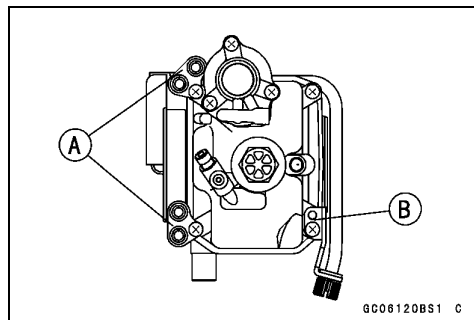

- Replace the O-rings with new ones.
- Fit the O-rings [A].
- Install:
 - Diaphragm [B]
 - Spring [C]
 - Acceleration Pump Cover
- Install the diaphragm so that its mark facing [D] outward.
- Tighten the bolts.

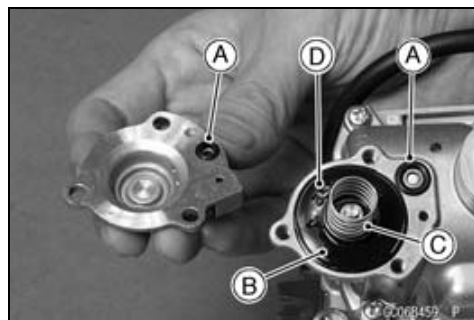

Carburetor

- Install the choke knob/starter plunger [A].

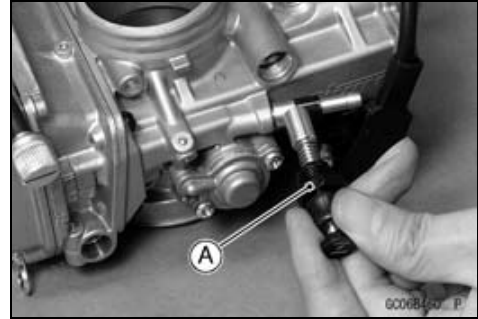

- Replace the O-rings [A] with the new ones.
- Install the fuel hose fitting [B].
- Tighten the screws.

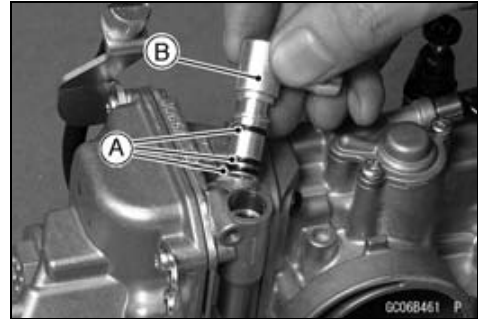

- Install all hoses [A].
- Install the carburetor (see Carburetor Installation).

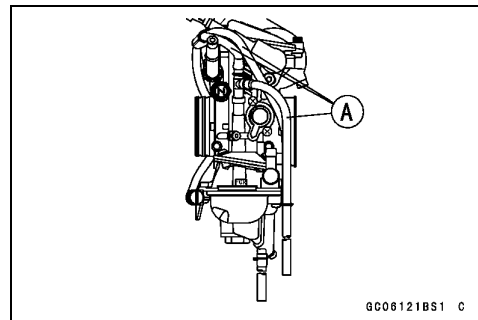

★ If turn the adjusting screw of the acceleration pump, follow the procedure below.

- Prepare an arbor [A] with the outside diameter of $\phi 5.4$.
- Open the throttle valve and insert the arbor at the bottom of the bore of the air cleaner side, and slowly close the throttle valve.

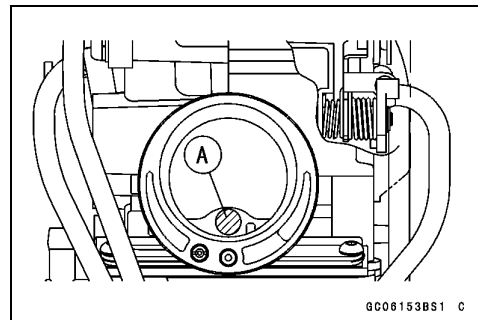

throttle Valve Height

Air Cleaner Side: 5.4 mm (0.213 in.)

(Reference) Engine Side: 3.4 mm (0.134 in.)

- Push the link lever [A] in the direction of the arrow [B] and adjust the timing with the adjusting screw [C] so it becomes no free play and the condition of no pushing down of the push rod [D]. (Tightening the adjusting screw makes more free play and loosening makes less free play.)

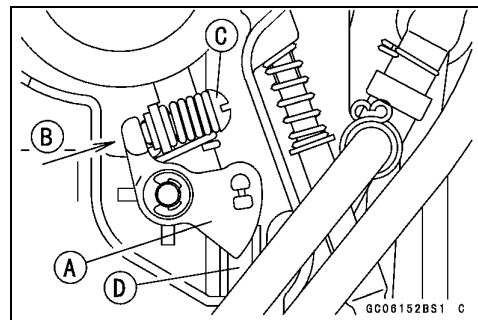

3-28 FUEL SYSTEM

Air Cleaner

Air Cleaner Housing Removal

- Remove:
 - Side Covers (see Side Cover Removal in the Frame chapter)
 - Seat (see Seat Removal in the Frame chapter)
 - Muffler (see Muffler Removal in the Engine Top End chapter)
 - Rear Fender [A] (see Rear Fender Removal in the Frame chapter)
 - Rear Frame Bolts [B]
- Loosen the air cleaner duct clamp [C].
- Remove the rear frame.

- Unscrew the bolts [A].
- Remove the air cleaner housing [B].

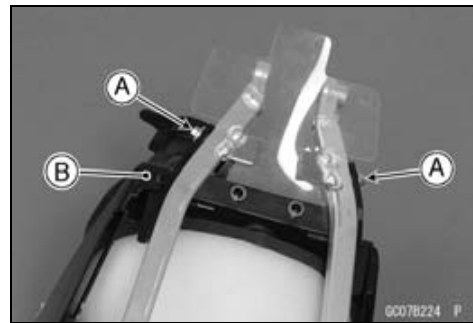
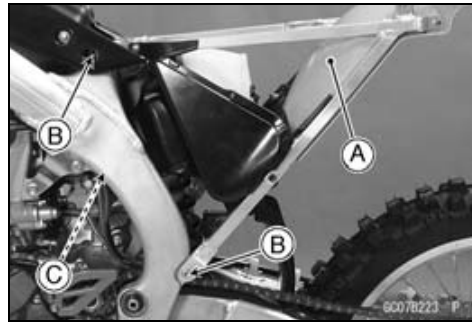

Air Cleaner Housing Installation

- Installation is the reverse of the removal.
- Tighten:
 - Torque - Air Cleaner Housing Bolts: 9.8 N·m (1.0 kgf·m, 87 in·lb)**
 - Rear Frame Mounting Bolts: 34 N·m (3.5 kgf·m, 25 ft·lb)**

Element Removal

- Remove:
 - Seat (see Seat Removal in the Frame chapter)
 - Wing Bolt [A]
 - Element [B]
- Stuff a clean, lint-free towel into the carburetor so no dirt is allowed to enter the carburetor.
- Wipe out the inside of the air cleaner housing with a clean damp towel.

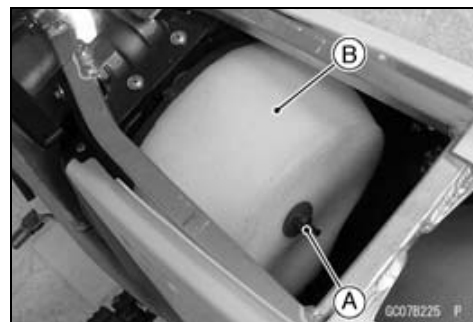

CAUTION

Check inside of the inlet tract and carburetor for dirt. If dirt is present, clean the intake tract and carburetor thoroughly. You may also need to replace the element and seal the housing and inlet tract.

Air Cleaner

Element Installation

- When installing the element, coat the lip of the element with a thick layer of all purpose grease [A] to assure a complete seal against the air cleaner element base. Also, coat the base where the lip of the element fits.
- Apply grease to all connections and screw holes in the air cleaner housing and intake tract.
- Take out the towel from the carburetor securely.

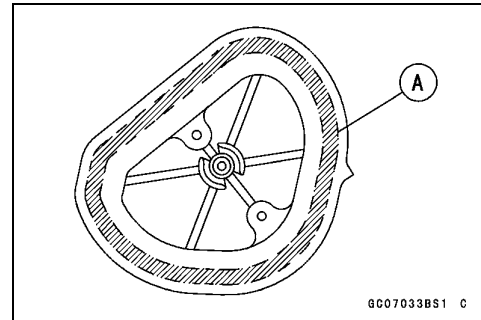

- Install the element so that its tab [A] faces upward and fit the frame projections [B] to the holes of the holder [C].
- Tighten the wing bolt [D].
- Install the seat (see Seat Installation in the Frame chapter).

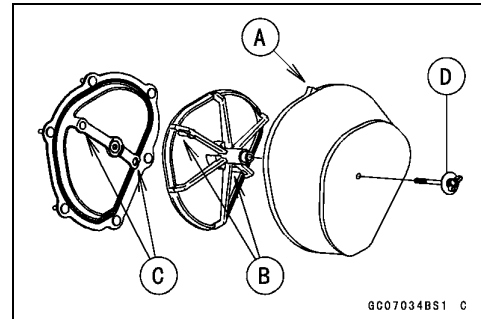

Element Cleaning and Inspection

- Refer to the Air Cleaner Element Cleaning and Inspection in the Periodic Maintenance chapter.

3-30 FUEL SYSTEM

Fuel Tank

Fuel Tank Removal

⚠ WARNING

Gasoline is extremely flammable and can be explosive under certain conditions. Always stop the engine and do not smoke. Make sure the area is well-ventilated and free from any source of flame or sparks; this includes any appliance with a pilot light.

- Turn the fuel tap lever [A] to the OFF position.
- Slide out the clamp [B] and pull the fuel hose [C] off the fuel tap [D].
- Remove the bolt [E].

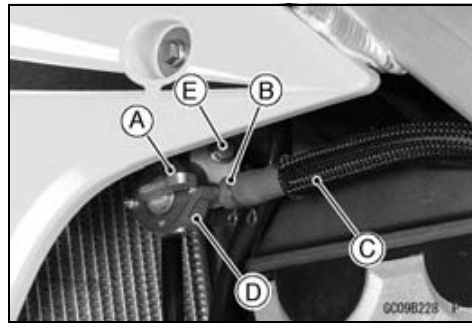

- Remove:
 - Seat (see Seat Removal in the Frame chapter)
 - Bolts [A]
- Remove the fuel tank mounting bolt [B] and band [C].
- Pull out the fuel tank breather hose [D] from the steering stem.
- Remove the fuel tank [E] together with the radiator shrouds.
- Drain the fuel.

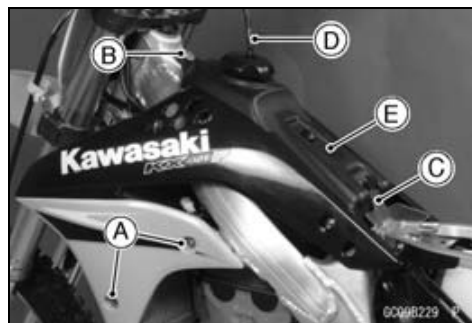

Fuel Tank Installation

- Check the rubber dampers [A] on the frame.
- ★ If the dampers are damaged or deteriorated, replace them.
- Be sure the fuel hose is clamped to the fuel tap to prevent leaks.
- Insert the fuel tank breather hose outlet end into the steering stem hole.

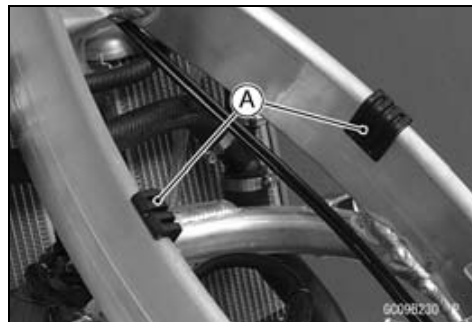

Fuel Filter Removal

- Remove the fuel tank and drain it (see Fuel Tank Removal).
- Remove the mounting bolts [A] and take out the fuel filter [B].

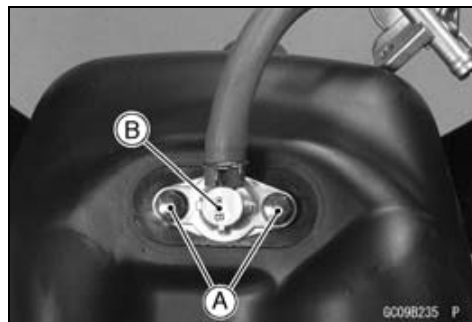

Fuel Filter Installation

- Be sure the O-ring is in good condition to prevent leaks.
- Be sure to clamp the fuel hose to the tap and fuel filter to prevent leaks.

Fuel Tank

Fuel Tank, Filter and Tap Cleaning

- Refer to the Fuel Tank, Filter and Tap Cleaning in the Periodic Maintenance chapter.

Fuel Tap and Filter Inspection

- Refer to the Fuel Tap and Filter Inspection in the Periodic Maintenance chapter.

Cooling System

Table of Contents

Exploded View	4-2
Specifications	4-4
Special Tool	4-5
Coolant	4-6
Coolant Level Inspection.....	4-6
Coolant Deterioration Inspection.....	4-6
Coolant Draining	4-6
Coolant Filling	4-7
Air Bleeding.....	4-7
Cooling System Pressure Testing	4-8
Cooling System Flushing	4-8
Water Pump.....	4-9
Water Pump Cover Removal	4-9
Water Pump Cover Installation	4-9
Impeller Removal.....	4-10
Impeller Installation.....	4-10
Water Pump Inspection.....	4-10
Oil Seal and Bearing Removal.....	4-10
Oil Seal Installation	4-11
Radiator.....	4-12
Radiator Removal	4-12
Radiator Installation	4-13
Radiator Inspection.....	4-13
Radiator Cap Inspection	4-13
Filler Neck Inspection.....	4-14
Water Hoses, Breather Hose Inspection.....	4-14
Water Hoses, Breather Hose Installation.....	4-14

4-2 COOLING SYSTEM

Exploded View

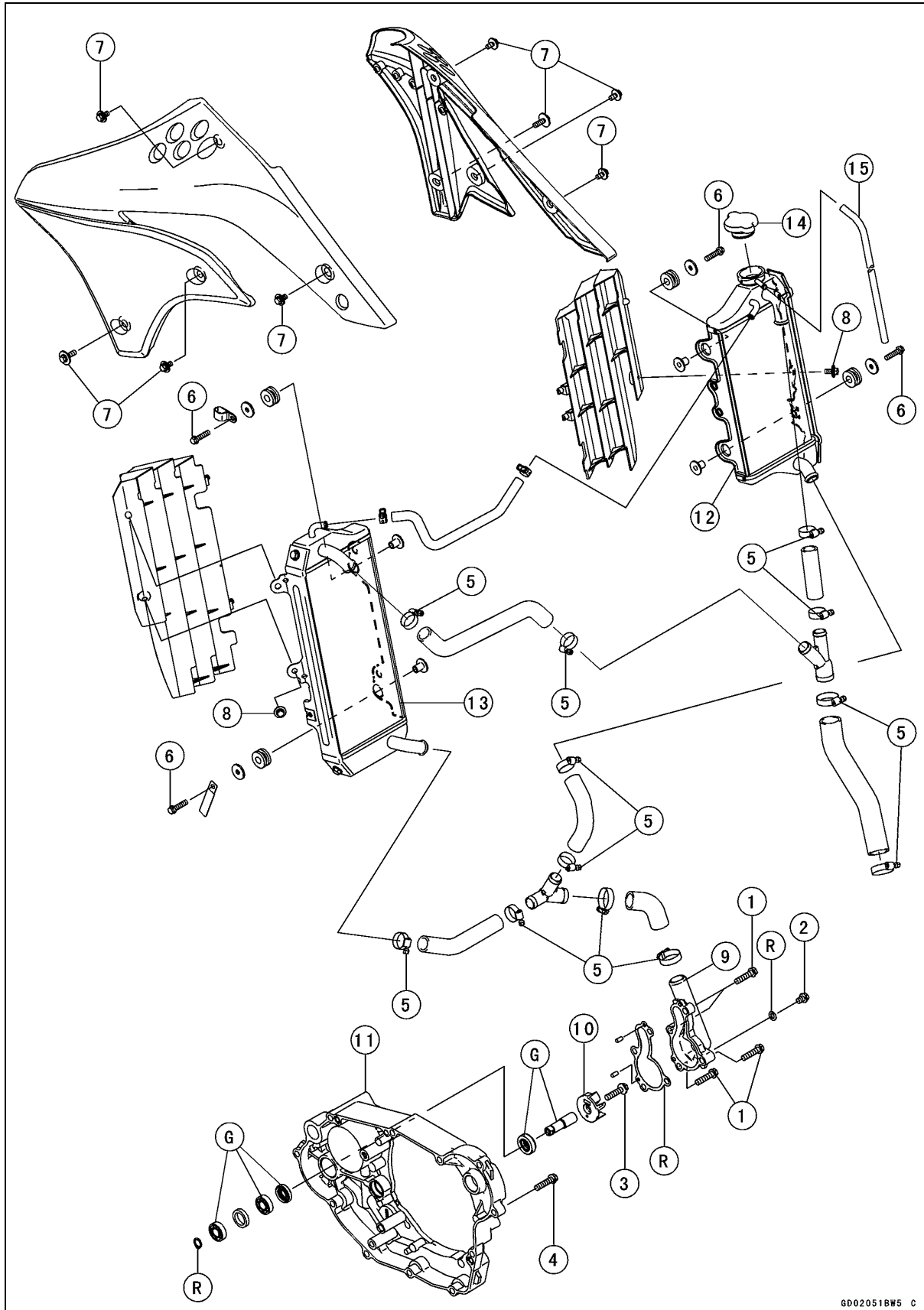

GD02051BWS C

Exploded View

No.	Fastener	Torque			Remarks
		N·m	kgf·m	ft·lb	
1	Water Pump Cover Bolts	9.8	1.0	87 in·lb	
2	Coolant Drain Bolt	6.9	0.70	61 in·lb	
3	Water Pump Impeller Bolt	9.8	1.0	87 in·lb	
4	Right Engine Cover Bolts	9.8	1.0	87 in·lb	
5	Water Hose Clamp Screws	1.5	0.15	13 in·lb	
6	Radiator Mounting Bolts	9.8	1.0	87 in·lb	
7	Radiator Shroud Bolts	9.8	1.0	87 in·lb	
8	Radiator Screen Bolts	9.8	1.0	87 in·lb	

- 9. Water Pump Cover
- 10. Impeller
- 11. Right Engine Cover
- 12. Right Radiator
- 13. Left Radiator
- 14. Radiator Cap
- 15. Radiator Overflow Hose
- G: Apply grease.
- R: Replacement Parts

4-4 COOLING SYSTEM

Specifications

Item	Service Limit
Coolant Type Color Mixed Ratio Freezing Point Total Amount	Permanent type antifreeze for aluminum engines and radiators Green Soft water 50%, antifreeze 50% -35°C (-31°F) 1.05 L (1.11 US qt.)
Radiator Cap Relief Pressure	112 ~ 142 kPa (1.14 ~ 1.45 kgf/cm ² , 16.2 ~ 20.6 psi)

Special Tool

**Bearing Driver Set:
57001-1129**

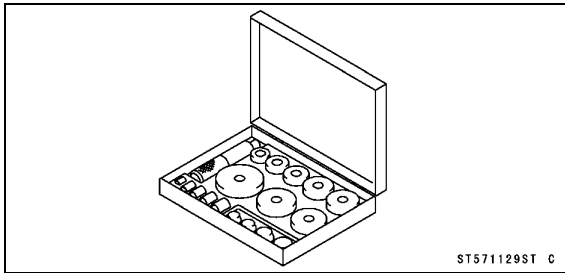

4-6 COOLING SYSTEM

Coolant

Check the coolant level each day before riding the motorcycle, and replenish coolant if the level is low. Change the coolant in accordance with the Periodic Maintenance Chart (see Periodic Maintenance chapter).

⚠ WARNING

To avoid burns, do not remove the radiator cap or try to inspect the coolant level or change the coolant when the engine is still hot. Wait until it cools down.

Coolant Level Inspection

- Refer to the Coolant Level Inspection in the Periodic Maintenance chapter.

Coolant Deterioration Inspection

- Refer to the Coolant Deterioration Inspection in the Periodic Maintenance chapter.

Coolant Draining

- The coolant should be changed periodically to ensure long engine life.

⚠ WARNING

To avoid burns, do not remove the radiator cap or try to change the coolant when the engine is still hot. Wait until it cools down.

Coolant on tires will make them slippery and can cause an accident and injury. Immediately wipe up or wash away any coolant that spills on the frame, engine or other painted parts. Since coolant is harmful to the human body, do not use for drinking.

- Remove the radiator cap [A].

NOTE

○Remove the radiator cap in two steps. First turn the cap counterclockwise to the first stop and wait there for a few seconds. Then push down and turn it further in the same direction and remove the cap.

- Place a container under the coolant drain bolt [A], and drain the coolant from the radiator and engine by removing the drain bolt on the water pump cover. Immediately wipe or wash out any coolant that spills on the frame, or engine.
- Inspect the old coolant for visual evidence of corrosion and abnormal smell (see Coolant Deterioration Inspection in the Periodic Maintenance chapter).

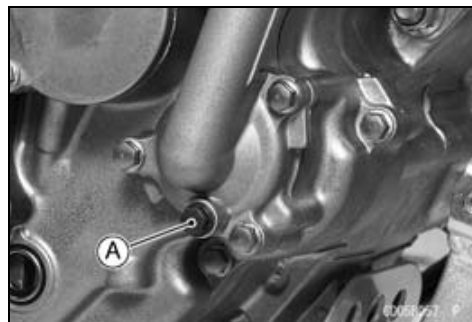

Coolant

Coolant Filling

CAUTION

Use coolant containing corrosion inhibitors made specifically for aluminum engines and radiators in accordance with the instruction of the manufacturer's. Soft or distilled water must be used with the antifreeze (see below for antifreeze) in the cooling system. If hard water is used in the system, it causes scale accumulation in the water passages, and considerably reduces the efficiency of the cooling system.

Recommended Coolant

Type:	Permanent type antifreeze (soft water and ethylene glycol plus corrosion and rust inhibitor chemicals for aluminum engines and radiators)
Color:	Green
Mixed ratio:	Soft water 50%, Coolant 50%
Freezing point:	-35°C (-31°F)
Total amount	1.05 L (1.11 US qt.)

- Install the drain bolt .
- Replace the gasket with a new one.

Torque - Coolant Drain Bolt: 6.9 N·m (0.70 kgf·m, 61 in·lb)

- Fill the radiator up to the bottom of the radiator filler neck [B] with coolant [A], and install the cap, turning it clockwise about 1/4 turn.
- Lean the motorcycle slightly to the right until the radiator filler neck is level to the ground so that the filler neck is located uppermost in order to exhaust the air accumulated in the radiator.

NOTE

- Pour in the coolant slowly so that it can expel the air from the engine and radiator. The radiator cap must be installed in two steps. First turn the cap clockwise to the first stop. Then push down on it and turn it the rest of the way.

- Check the cooling system for leaks.

Air Bleeding

Before putting the motorcycle into operation, any air trapped in the cooling system must be removed as follows.

- Start the engine, warm up the engine thoroughly, and then stop the engine. Wait until the engine cools down.
- Remove the radiator cap.
- Check the coolant level (see Coolant Level Inspection in the Periodic Maintenance chapter).
- ★ If the coolant level is low, add coolant up to the bottom of the filler neck.
- Install the radiator cap.
- Check the cooling system for leaks.

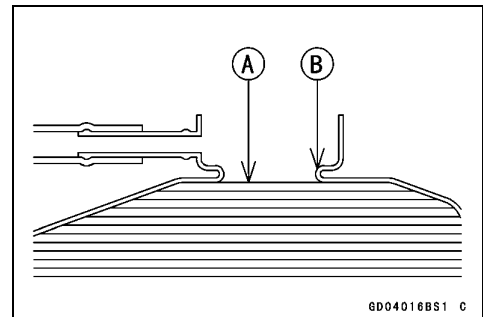

4-8 COOLING SYSTEM

Coolant

Cooling System Pressure Testing

CAUTION

During pressure testing, do not exceed the pressure for which the system is designed to work. The maximum pressure is 123 kPa (1.25 kgf/cm², 18 psi).

- Remove the radiator cap, and install a cooling system pressure tester [A] and adapter [B] on the radiator filler neck [C].

NOTE

○ *Wet the adapter cap sealing surfaces with water or coolant to prevent pressure leaks.*

- Build up pressure in the system carefully until the pressure reaches 123 kPa (1.25 kgf/cm², 18 psi).
- Watch the gauge for at least 6 seconds. If the pressure holds steady, the cooling system is all right.
- Remove the pressure tester, replenish the coolant, and install the radiator cap.
- ★ If the pressure drops and no external source is found, check for internal leaks. Check the cylinder head gasket for leaks.

Cooling System Flushing

Over a period of time, the cooling system accumulates rust, scale, and lime in the water jacket and radiator. When this accumulation is suspected or observed, flush the cooling system. If this accumulation is not removed, it will clog up the water passages and considerably reduce the efficiency of the cooling system.

- Drain the cooling system.
- Fill the cooling system with fresh water mixed with a flushing compound.

CAUTION

Avoid the use of a flushing compound which is harmful to the aluminum engine and radiator. Carefully follow the instructions supplied by the manufacture of the cleaning product.

- Warm up the engine, and run it at normal operating temperature for about ten minutes.
- Stop the engine, and drain the cooling system after the coolant cools down.
- Fill the system with fresh water.
- Warm up the engine and drain the system after the coolant cools down.
- Repeat the previous two steps once more.
- Fill the system with a permanent type coolant, and bleed the air from the system (see Air Bleeding).



Water Pump

Water Pump Cover Removal

- Unscrew the drain bolt [A], and drain the coolant (see Coolant Draining).
- Loosen the clamp screw [B], and remove the water hose [C] from the water pump cover.
- Unscrew the cover bolts [D].

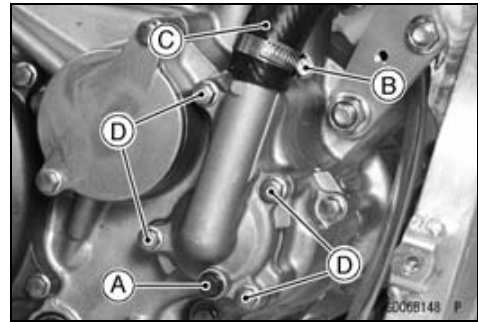

- Using the pry points [A], remove the pump cover [B].

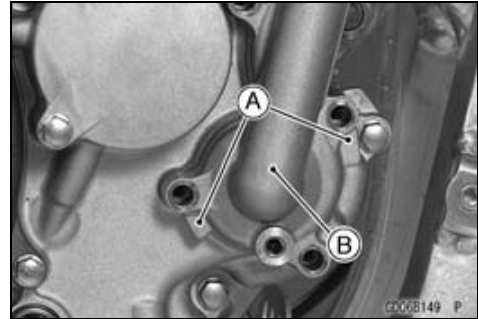

Water Pump Cover Installation

- Replace the pump cover gasket [A] with a new one.
- Check to see that dowel pins [B] are in place in the mating surfaces of the right engine cover.

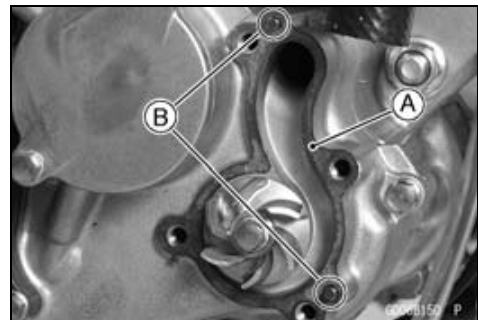

- Install the water pump cover.
- Replace the drain bolt washer with a new ones.
- Tighten:
 - Torque - Water Pump Cover Bolts [A]: 9.8 N·m (1.0 kgf·m, 87 in·lb)**
 - Coolant Drain Bolt [B]: 6.9 N·m (0.70 kgf·m, 61 in·lb)**

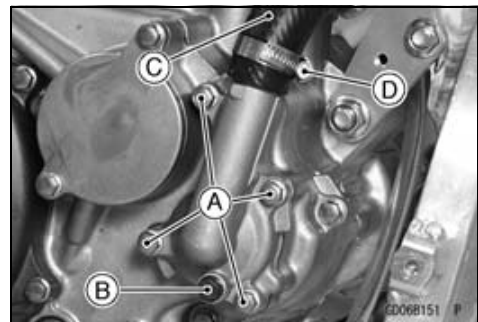

- Insert the water hose [C] into the water pump cover.
- Tighten:
 - Torque - Water Hose Clamp Screw [D]: 1.5 N·m (0.15 kgf·m, 13 in·lb)**
- Fill the cooling system (see Coolant Filling).
- Bleed the air from the cooling system.
- Check the engine oil level and add the engine oil.

4-10 COOLING SYSTEM

Water Pump

Impeller Removal

- Drain:
Coolant (see Coolant Draining)
- Remove:
Water Pump Cover (see Water Pump Cover Removal)
Impeller Bolt [A]
Impeller [B]

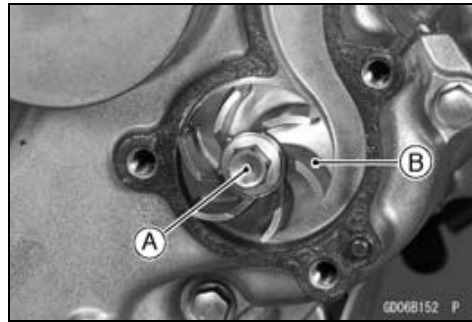

Impeller Installation

- Install:
Impeller [A]
- Tighten:
Torque - Water Pump Impeller Bolt [B]: 9.8 N·m (1.0 kgf·m, 87 in·lb)
- Install:
Water Pump Cover (see Water Pump Cover Installation)

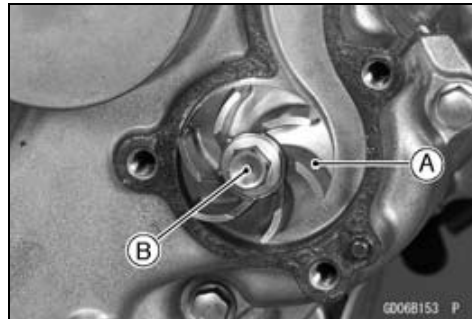

Water Pump Inspection

- Visually check the impeller [A].
- ★ If the surface is corroded, or if the blades [B] are damaged, replace the impeller.

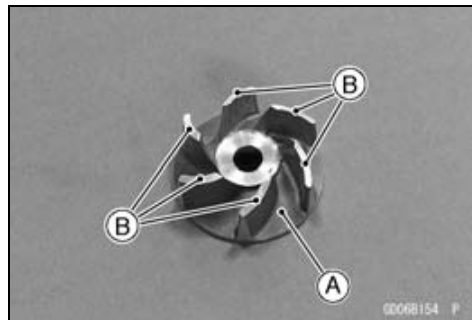

- Check the drainage outlet passage [A] at the bottom of the right engine cover for coolant leaks.
- ★ If the oil seal is damaged, the coolant leaks through the seal and drains through the passage. Replace the oil seals.



Oil Seal and Bearing Removal

- Remove:
Impeller (see Impeller Removal)
Right Engine Cover (see Right Engine Cover Removal in the Engine Right Side chapter)
Circlip [A]
Water Pump Shaft [B]

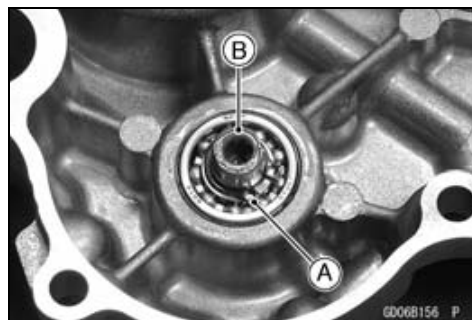

Water Pump

- Insert a bar [A] into the water pump shaft hole from the outside of the right engine cover, and remove the ball bearing [B] by tapping [C] evenly around the bearing inner race.
- Remove the spacer [D].
- Remove the ball bearing [E] and oil seal [F] from the right engine cover in the same way as ball bearing removal.

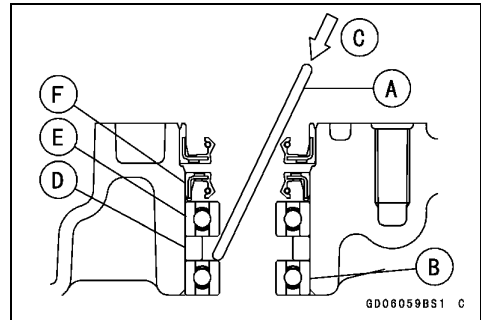

- Insert a bar [A] into the water pump shaft hole from the inside of the right engine cover, and remove the oil seal [B] by tapping [C] evenly around the seal lips.

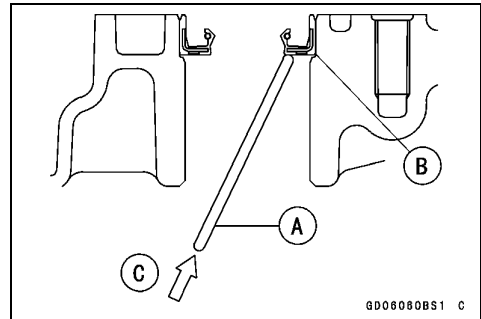

Oil Seal Installation

CAUTION

If the oil seal or ball bearing is removed, replace all of them with new ones at the same time

- Be sure to replace the oil seals.
- Apply plenty of high temperature grease to the oil seal lips.
- Press in the new oil seal [A] using a bearing driver set from the outside of the right engine cover so that the seal bottom surface is flush with the end face [B] of the right engine cover.
- Press in the new oil seal [C] using a bearing driver set from the outside of the right engine cover so that the oil seal surface is flush [D] with the surface of the right engine cover.

Special Tool - Bearing Driver Set: 57001-1129

- Press the ball bearing [A] together with the spacer [B] into the hole until the face of the bearing is even [C] with the end of the hole.

Special Tool - Bearing Driver Set: 57001-1129

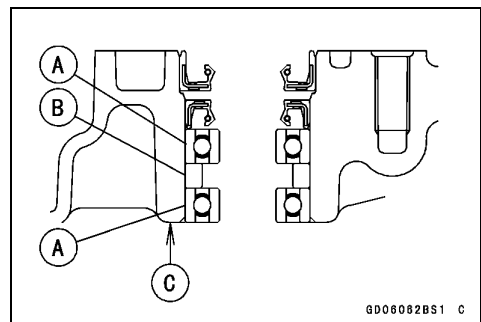
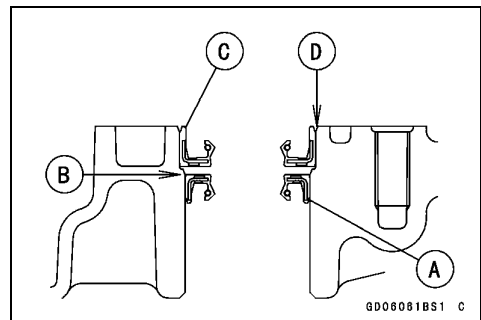

4-12 COOLING SYSTEM

Radiator

Radiator Removal

- Drain the coolant (see Coolant Draining)

- Remove:

Radiator Shrouds

- Loosen:

Clamp Screws [A]

Clamp [B]

- Remove:

Water Hoses [C]

Bolts [D]

Left Radiator Screen [E]

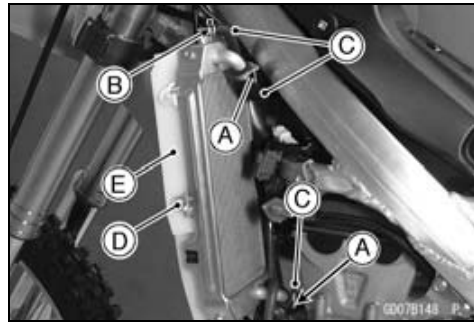

- Unscrew the radiator mounting bolts [A].

- Remove the left radiator [B].

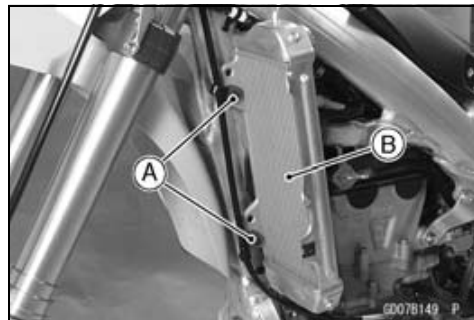

- Loosen:

Clamp Screws [A]

- Remove:

Radiator Hoses [B]

Bolt [C]

Right Radiator Screen [D]

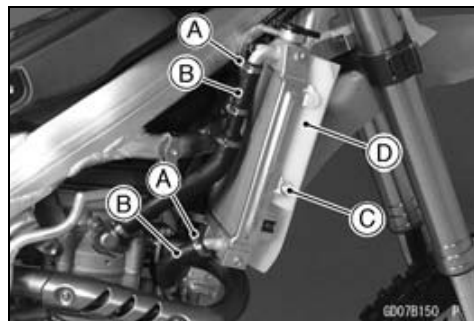

- Remove:

Radiator Mounting Bolts [A]

Right Radiator [B]

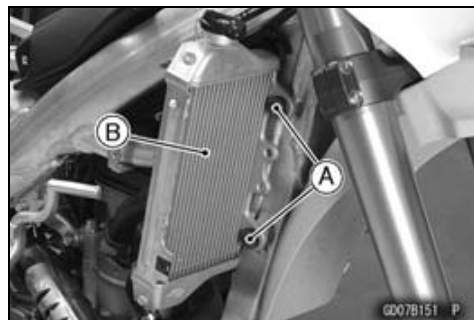

Radiator

Radiator Installation

- Fit the projections [A] of the screen in the holes [B] of the radiator.

Torque - Water Hose Clamp Screws: 1.5 N·m (0.15 kgf·m, 13 in·lb)

Radiator Mounting Bolts: 9.8 N·m (1.0 kgf·m, 87 in·lb)

Radiator Screen Bolts: 9.8 N·m (1.0 kgf·m, 87 in·lb)

Radiator Shroud Bolts: 9.8 N·m (1.0 kgf·m, 87 in·lb)

- Route the water and breather hoses correctly (see Cable, Wire, and Hose Routing section in the Appendix chapter).
- Fill the cooling system with a permanent type coolant.

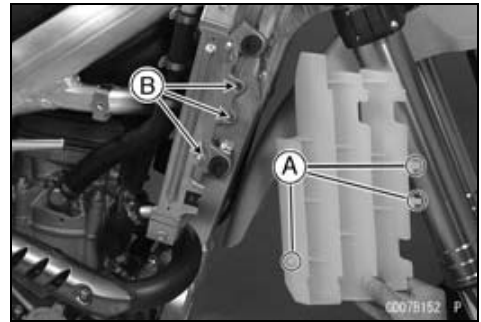

Radiator Inspection

- Check the radiator core.
- ★ If there are obstructions to air flow, remove them.
- ★ If the corrugated fins are deformed, carefully straighten them with the thin blade of a screwdriver [A].

CAUTION

Do not tear the radiator tubes while straightening the fins.

- ★ If the air passages of the radiator core are blocked more than 20% by unremovable obstructions or irreparably deformed fins, replace the radiator with a new one.

CAUTION

When cleaning the radiator with steam cleaner, be careful of the following to prevent radiator damage. Keep the steam gun [A] away more than 0.5 m (1.64 ft) [B] from the radiator core. Hold the steam gun perpendicular to the core surface. Run the steam gun following the core fin direction [C].

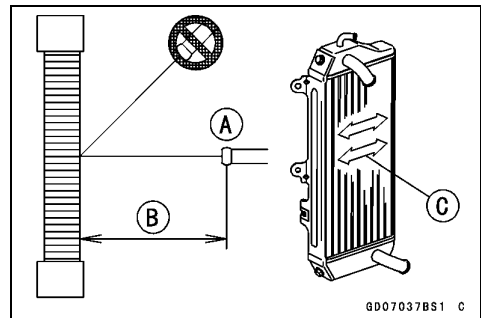
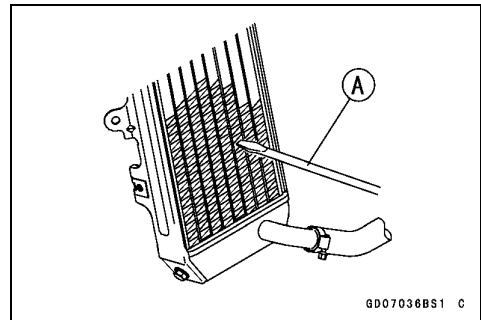

Radiator Cap Inspection

- Check the condition of the valve spring [B], and the top and bottom valve seals [A] of the radiator cap.
- ★ If any one of them shows visible damage, replace the cap.

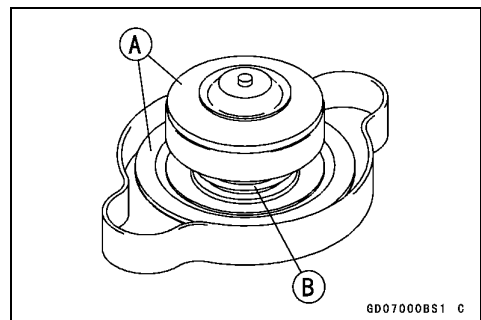

4-14 COOLING SYSTEM

Radiator

- Wet the top and bottom valve seals with water or coolant to prevent pressure leaks.
- Install the cap [A] on a cooling system pressure tester [B].
- Watching the pressure gauge, slowly pump the pressure tester to build up the pressure. The gauge hand must remain within the relief pressure range in the table below at least 6 seconds. Continue to pump the tester until the relief valve opens, indicated by the gauge hand flicking downward. The relief valve must open within the specified range.

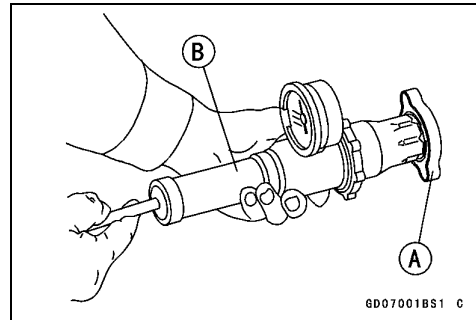

Radiator Cap Relief Pressure

Standard: 112 ~ 142 kPa (1.14 ~ 1.45 kgf/cm², 16.2 ~ 20.6 psi)

- ★ If the cap cannot hold the pressure, or if the relief pressure is too high or too low, replace the cap with a new one.

Filler Neck Inspection

- Check the radiator filler neck for signs of damage.
- Check the condition of the top and bottom sealing seats [A] in the filler neck. They must be smooth and clean for the radiator cap to function properly.



Water Hoses, Breather Hose Inspection

- Refer to the Water Hoses and Connections Inspection in the Periodic Maintenance chapter.

Water Hoses, Breather Hose Installation

- Install the water hoses or breather hose being careful to follow the performed bends (see Cable, Wire, and Hose Routing section in the Appendix chapter). Avoid sharp bending, kinking, flattening, or twisting.
- Tighten the hose clamps securely.

Torque - Water Hose Clamp Screws: 1.5 N·m (0.15 kgf·m, 13 in·lb)

Engine Top End

Table of Contents

Exploded View	5-2	Valve Installation	5-24
Specifications	5-6	Valve Guide Removal	5-25
Special Tools and Sealant	5-9	Valve Guide Installation	5-25
Cylinder Head Cover	5-12	Valve/Valve Guide Clearance Measurement (Wobble Method)	5-26
Cylinder Head Cover Removal	5-12	Valve Seat Inspection	5-27
Cylinder Head Cover Installation .	5-12	Valve Seat Repair	5-27
Camshaft Chain Tensioner	5-13	Cylinder and Piston	5-32
Camshaft Chain Tensioner Removal	5-13	Cylinder Removal.....	5-32
Camshaft Chain Tensioner Installation	5-13	Piston Removal.....	5-32
Camshaft	5-15	Cylinder and Piston Installation....	5-32
Camshaft Removal	5-15	Cylinder Wear Inspection.....	5-34
Camshaft Installation	5-16	Piston Wear Inspection	5-34
Camshaft Chain Removal	5-18	Piston/Cylinder Clearance Inspection.....	5-34
Camshaft Chain Installation.....	5-18	Piston Ring/Ring Groove Clearance Inspection	5-34
Camshaft and Camshaft Cap Wear Inspection	5-19	Piston Ring Groove Width Inspection.....	5-35
Camshaft Runout Inspection.....	5-19	Piston Ring Thickness Inspection	5-35
Cam Wear Inspection	5-19	Piston Ring End Gap Measurement	5-35
Cylinder Head.....	5-20	Piston, Piston Pin, Connecting Rod Wear Inspection.....	5-36
Cylinder Compression Measurement	5-20	Carburetor Holder.....	5-37
Cylinder Head Removal	5-21	Carburetor Holder Installation	5-37
Cylinder Head Installation	5-22	Muffler.....	5-38
Cylinder Head Cleaning.....	5-23	Muffler Removal.....	5-38
Cylinder Head Warp Inspection ...	5-23	Muffler Installation.....	5-38
Valves	5-24	Muffler Baffle Replacement.....	5-38
Valve Clearance Inspection	5-24		
Valve Removal	5-24		

5-2 ENGINE TOP END

Exploded View

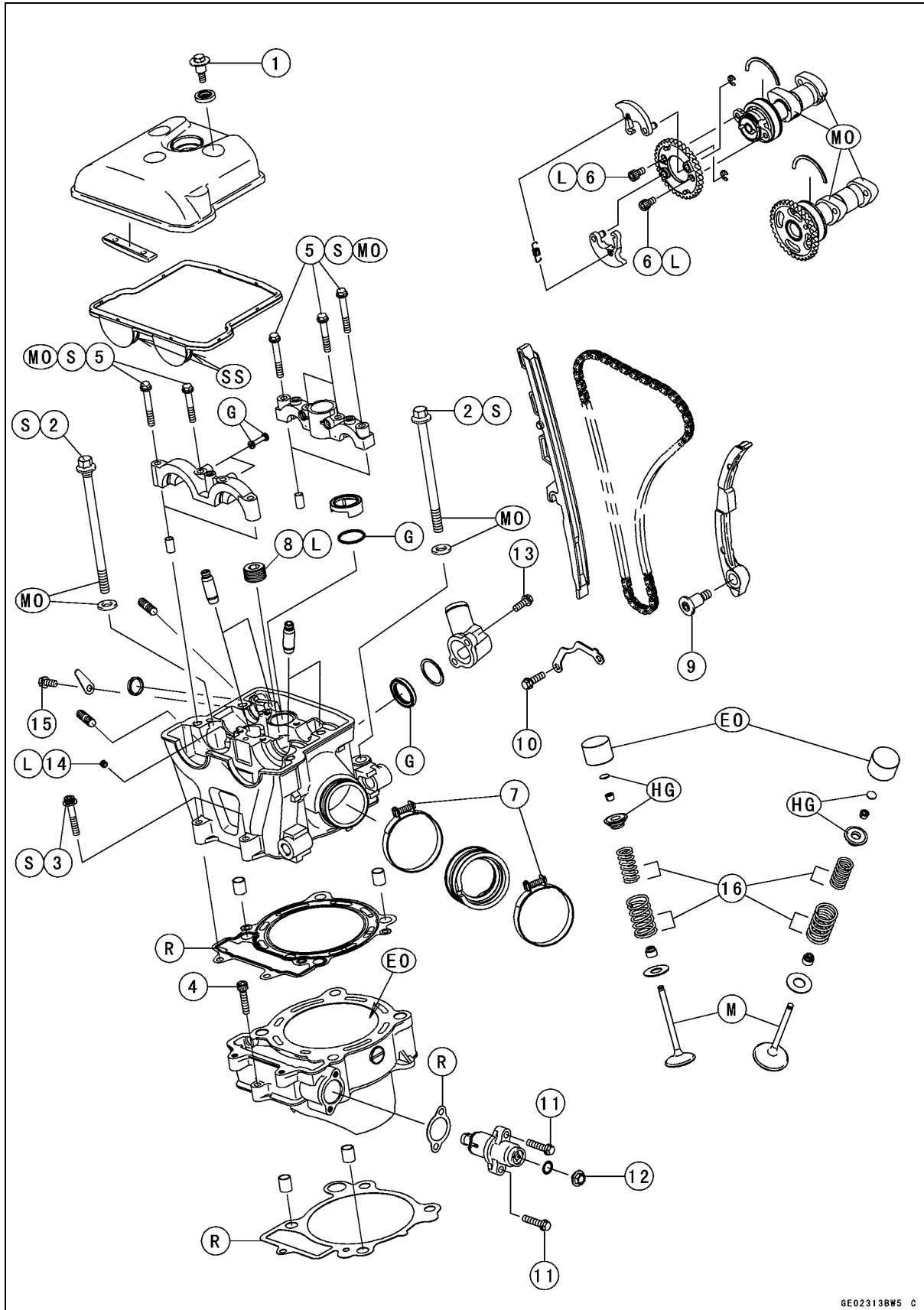

GE02313BWS C

Exploded View

No.	Fastener	Torque			Remarks
		N·m	kgf·m	ft·lb	
1	Cylinder Head Cover Bolts	9.8	1.0	87 in·lb	
2	Cylinder Head Bolts (M10)	59	6.0	44	S, MO
3	Cylinder Head Bolts (M6)	12	1.2	104 in·lb	S
4	Cylinder Bolt	12	1.2	104 in·lb	
5	Camshaft Cap Bolts	9.8	1.0	87 in·lb	S, MO
6	Camshaft Sprocket Bolts	12	1.2	104 in·lb	L
7	Carburetor Holder Clamp Screws	2.0	0.20	17 in·lb	
8	Plug	20	2.0	15	L
9	Rear Camshaft Chain Guide Bolt	15	1.5	11	
10	Lower Camshaft Chain Guide Bolts	9.8	1.0	87 in·lb	
11	Chain Tensioner Mounting Bolts	9.8	1.0	87 in·lb	
12	Chain Tensioner Cap Bolt	5.0	0.51	44 in·lb	
13	Water Hose Fitting Bolts	9.8	1.0	87 in·lb	
14	Oil Line Plug	3.0	0.31	27 in·lb	L
15	Decompressor Plug Plate Bolt	9.8	1.0	87 in·lb	

16. Closed coil end faces down.

EO: Apply engine oil.

G: Apply grease.

HG: Apply high temperature grease.

L: Apply non-permanent locking agent.

M: Apply molybdenum disulfide grease.

MO: Apply molybdenum disulfide oil.

R: Replacement Parts

S: Follow the specific tightening sequence.

SS: Apply silicon sealant.

5-4 ENGINE TOP END

Exploded View

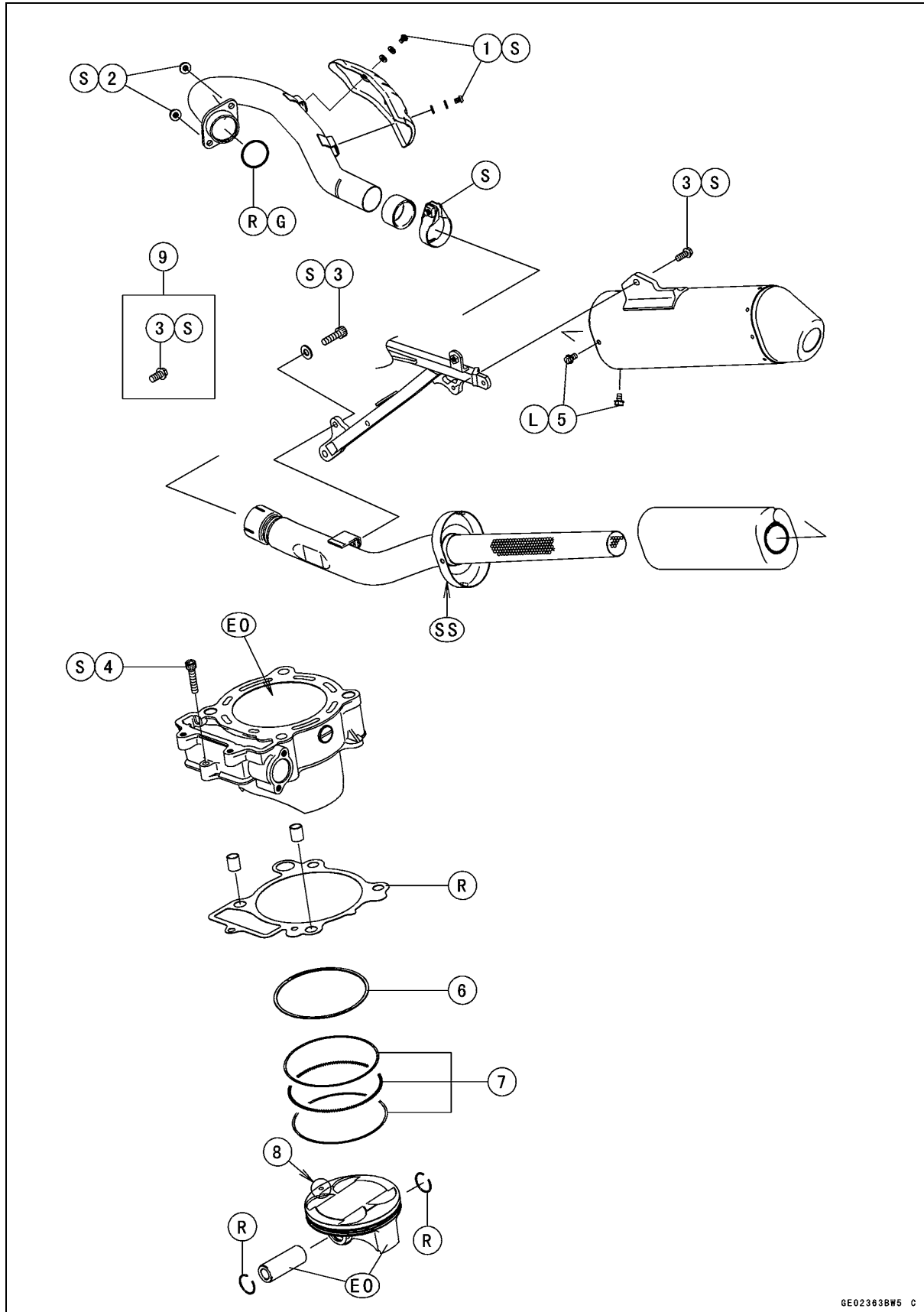

GE02363BWS C

Exploded View

No.	Fastener	Torque			Remarks
		N·m	kgf·m	ft·lb	
1	Exhaust Pipe Cover Bolts	12	1.2	104 in·lb	
2	Exhaust Pipe Holder Nuts	21	2.1	15	
3	Muffler Mounting Bolts	21	2.1	15	
4	Cylinder Bolt	12	1.2	104 in·lb	S
5	Muffler Pipe Mounting Bolts	–	–	–	L

6. Top Ring

7. Oil Ring

8. Circle Mark

9. KX450D6F ~ D7F

EO: Apply engine oil.

G: Apply high temperature grease.

L: Apply non-permanent locking agent.

R: Replacement Parts

S: Follow the specific tightening sequence.

SS: Apply silicone sealant.

5-6 ENGINE TOP END

Specifications

Item	Standard	Service Limit
Camshafts		
Cam Height:		
Exhaust	36.943 ~ 37.057 mm (1.4544 ~ 1.4589 in.)	36.84 mm (1.450 in.)
Inlet	37.743 ~ 37.857 mm (1.4859 ~ 1.4904 in.)	37.64 mm (1.482 in.)
Camshaft Journal Clearance	0.020 ~ 0.062 mm (0.00079 ~ 0.0024 in.)	0.15 mm (0.0059 in.)
Camshaft Journal Diameter	22.959 ~ 22.980 mm (0.90390 ~ 0.90472 in.)	22.93 mm (0.9072 in.)
Camshaft Journal Inside Diameter	23.000 ~ 23.021 mm (0.90551 ~ 0.90634 in.)	23.08 mm (0.9087 in.)
Camshaft Runout	TIR 0.02 mm (0.0008 in.) or less	TIR 0.1 mm (0.004 in.)
Cylinder Head		
Cylinder Compression	(Usable range) 450 ~ 750 kPa (4.59 ~ 7.65 kg/cm ² , 65.2 ~ 109 psi) @ 5 kicks.	— — —
Cylinder Head Warp	— — —	0.05 mm (0.0020 in.)
Valve		
Valve Clearance:		
Exhaust	0.17 ~ 0.22 mm (0.0067 ~ 0.0087 in.)	— — —
Inlet	0.10 ~ 0.15 mm (0.0039 ~ 0.0059 in.)	— — —
Valve Stem Bend	TIR 0.01 mm (0.0004 in.) or less	TIR 0.05 mm (0.002 in.)
Valve Stem Diameter:		
Exhaust	5.455 ~ 5.470 mm (0.2148 ~ 0.2154 in.)	5.44 mm (0.214 in.)
Inlet	5.465 ~ 5.480 mm (0.2152 ~ 0.2157 in.)	5.45 mm (0.215 in.)
Valve Guide Inside Diameter:		
Exhaust	5.500 ~ 5.512 mm (0.2165 ~ 0.2170 in.)	5.58 mm (0.220 in.)
Inlet	5.500 ~ 5.512 mm (0.2165 ~ 0.2170 in.)	5.58 mm (0.220 in.)
Valve/valve Guide Clearance (wobble method):		
Exhaust	0.09 ~ 0.16 mm (0.0035 ~ 0.0063 in.)	0.36 mm (0.014 in.)
Inlet	0.06 ~ 0.14 mm (0.0024 ~ 0.0055 in.)	0.33 mm (0.013 in.)
Valve Seat Cutting Angle	45°, 32°, 60°	— — —
Valve Seat Surface Outside Diameter:		
Exhaust	30.4 ~ 30.6 mm (1.197 ~ 1.205 in.)	— — —
Inlet	35.4 ~ 35.6 mm (1.39 ~ 1.40 in.)	— — —
Valve Seat Surface Width:		
Exhaust	0.8 ~ 1.2 mm (0.03 ~ 0.047 in.)	— — —
Inlet	0.5 ~ 1.0 mm (0.02 ~ 0.039 in.)	— — —
Valve Spring Free Length:		
Exhaust		
Outer	38.92 mm (1.532 in.)	37.5 mm (1.48 in.)
Inner	35.67 mm (1.404 in.)	34.2 mm (1.35 in.)
Inlet		
Outer	39.28 mm (1.546 in.)	37.8 mm (1.49 in.)
Inner	36.04 mm (1.419 in.)	35.7 mm (1.40 in.)

Specifications

Item	Standard	Service Limit
Cylinder and Pistons		
Cylinder Inside Diameter	96.000 ~ 96.012 mm (3.7795 ~ 3.7800 in.)	96.10 mm (3.783 in.)
Piston Diameter	95.970 ~ 95.980 mm (3.7783 ~ 3.7787 in.)	95.82 mm (3.772 in.)
Piston/Cylinder Clearance	0.020 ~ 0.042 mm (0.00079 ~ 0.0016 in.)	— — —
Piston Ring/Ring Groove Clearance:		
Top	0.04 ~ 0.07 mm (0.002 ~ 0.003 in.)	0.17 mm (0.0067 in.)
Piston Ring Groove Width:		
Top	1.03 ~ 1.05 mm (0.0406 ~ 0.0413 in.)	1.1 mm (0.043 in.)
Piston Ring Thickness:		
Top	0.970 ~ 0.990 mm (0.0381 ~ 0.0390 in.)	0.90 mm (0.035 in.)
Piston Ring End Gap:		
Top	0.25 ~ 0.35 mm (0.0098 ~ 0.014 in.)	0.6 mm (0.02 in.)
Oil	0.15 ~ 0.50 mm (0.0059 ~ 0.020 in.)	0.8 mm (0.03 in.)
Piston Pin Diameter	18.991 ~ 19.000 mm (0.74768 ~ 0.74803 in.)	18.95 mm (0.7461 in.)
Piston Pin Hole Diameter	19.004 ~ 19.010 mm (0.74819 ~ 0.74842 in.)	19.08 mm (0.7512 in.)
Connecting Rod Small End Inside Diameter	19.019 ~ 19.030 mm (0.74878 ~ 0.74921 in.)	19.07 mm (0.7508 in.)

TIR: Total Indicator Readings.

5-8 ENGINE TOP END

Specifications

Cam Height

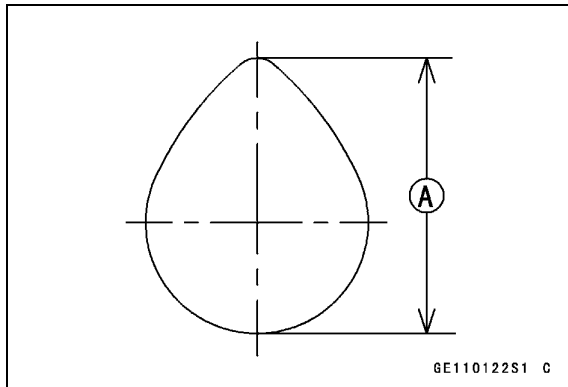

Cam Height [A]

Camshaft Runout

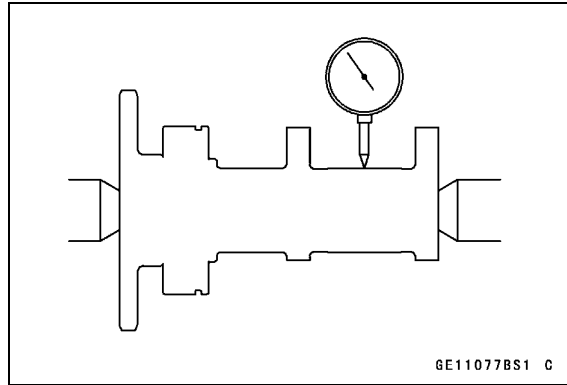

Valve Stem Diameter

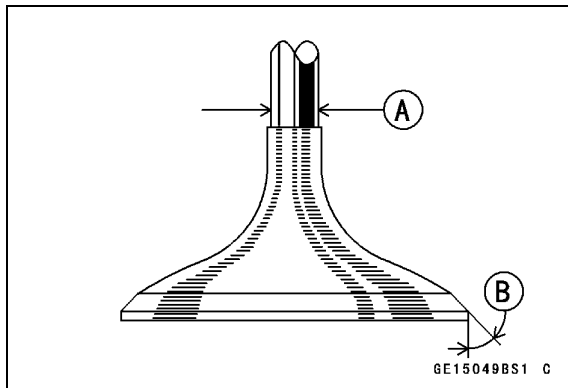

Valve Stem Diameter [A]
45° [B]

Valve Stem Bend

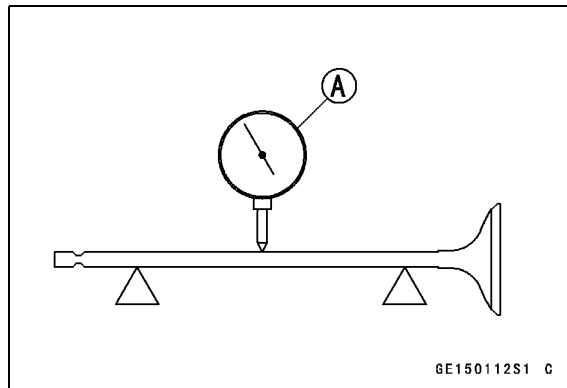

Dial Gauge [A]

Special Tools and Sealant

Compression Gauge, 20 kg/cm²:
57001-221

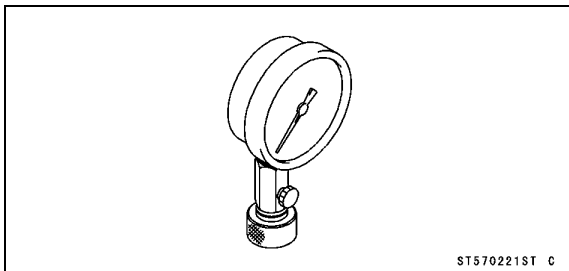

Valve Seat Cutter, 45° - φ35:
57001-1116

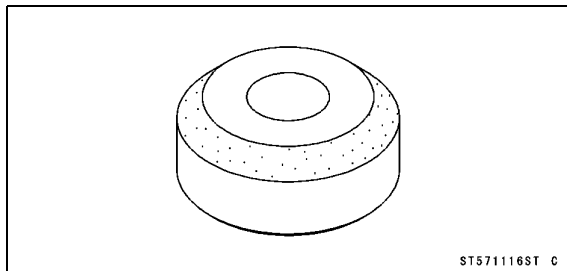

Valve Spring Compressor Assembly:
57001-241

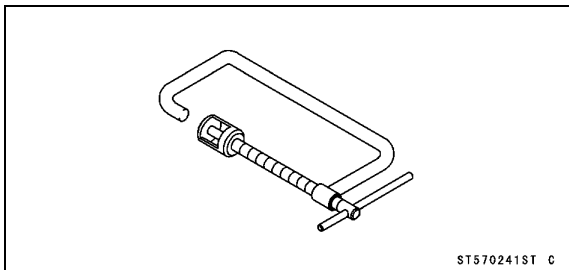

Valve Seat Cutter, 32° - φ35:
57001-1121

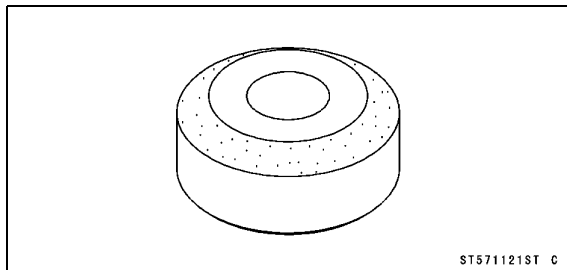

Valve Guide Arbor, φ5.5:
57001-1021

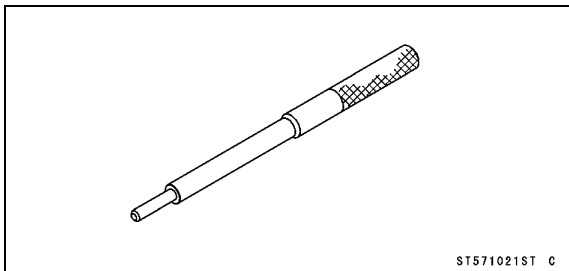

Valve Seat Cutter, 32° - φ38.5:
57001-1122

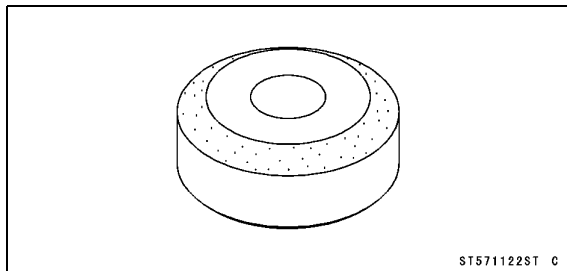

Valve Guide Reamer, φ5.5:
57001-1079

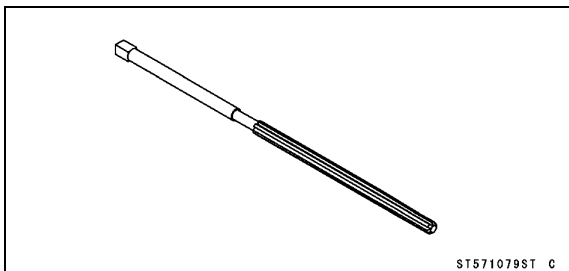

Valve Seat Cutter Holder, φ5.5:
57001-1125

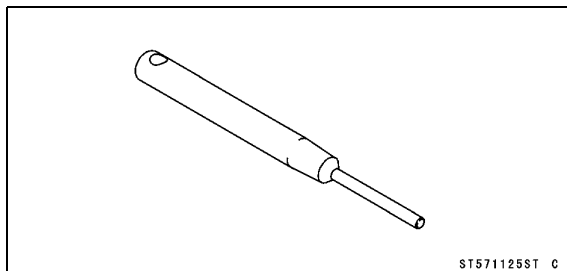

Piston Ring Compressor Grip:
57001-1095

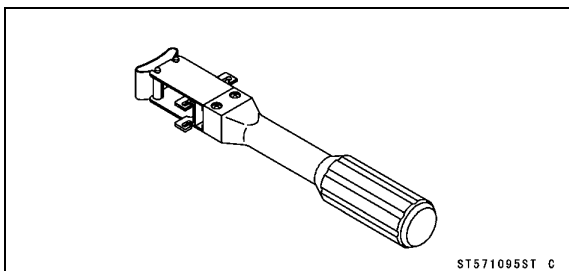

Valve Seat Cutter Holder Bar:
57001-1128

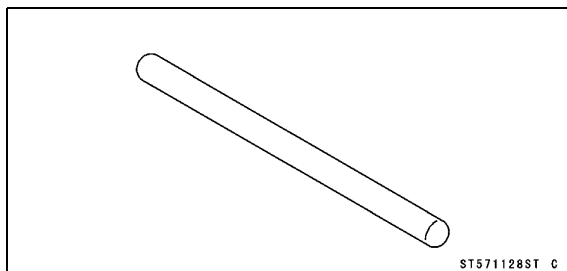

5-10 ENGINE TOP END

Special Tools and Sealant

Valve Seat Cutter, 55° - ϕ 35:
57001-1247

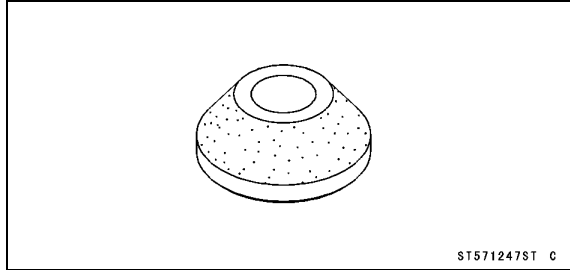

Valve Seat Cutter, 45° - ϕ 40:
57001-1496

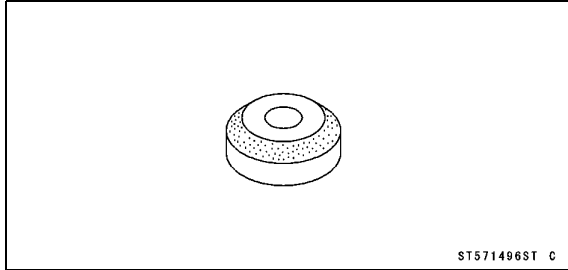

Spark Plug Wrench, Hex 16:
57001-1262

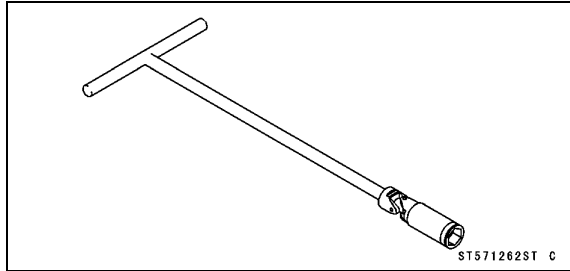

Valve Seat Cutter, 55° - ϕ 38.5:
57001-1497

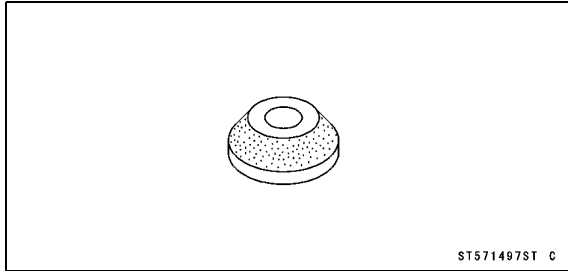

Compression Gauge Adapter, M10 × 1.0:
57001-1317

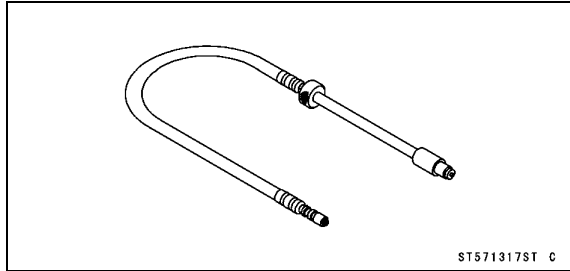

Valve Guide Driver:
57001-1564

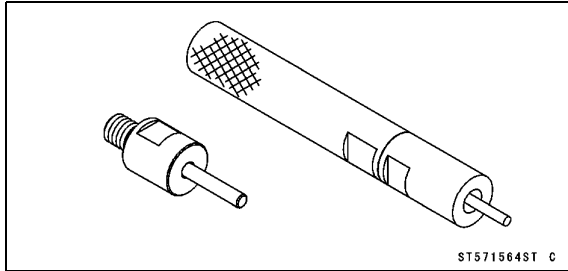

Piston Ring Compressor Belt, ϕ 95 ~ ϕ 108:
57001-1358

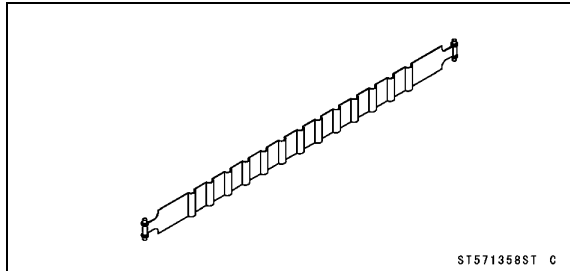

Piston Pin Puller:
57001-1568

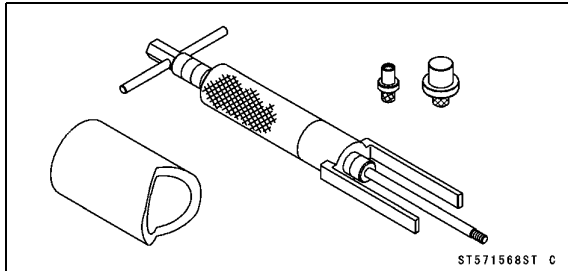

Filler Cap Driver:
57001-1454

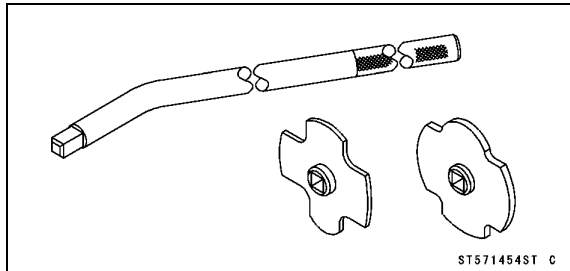

Valve Spring Compressor Adapter, ϕ 24:
57001-1586

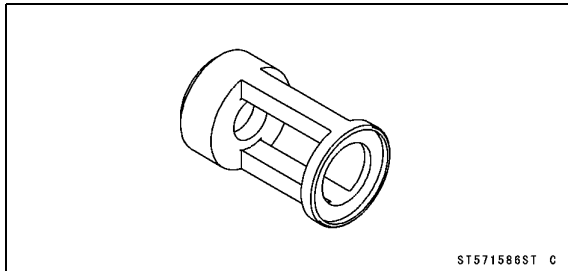

Special Tools and Sealant

**Valve Guide Driver Attachment D:
57001-1659**

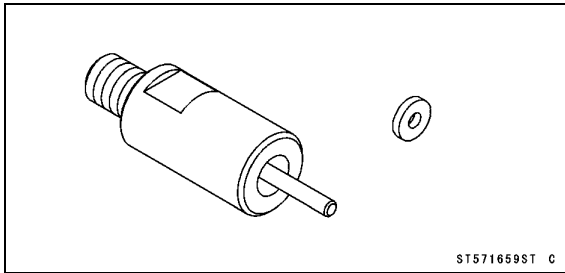

**Kawasaki Bond (Silicone Sealant):
92104-0004**

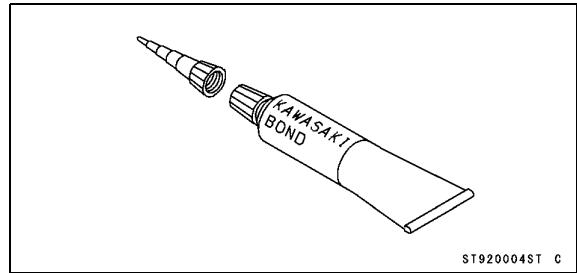

5-12 ENGINE TOP END

Cylinder Head Cover

Cylinder Head Cover Removal

- Remove:
 - Fuel Tank (see Fuel Tank Removal in the Fuel System chapter)
 - Spark Plug Cap
- Remove the cylinder head cover bolts [A] and remove the cylinder head cover [B].

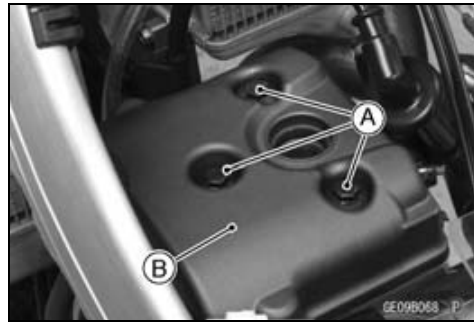

Cylinder Head Cover Installation

- Apply silicon sealant [A] to the cylinder head as shown.
Sealant - Kawasaki Bond (Silicone Sealant): 92104-0004

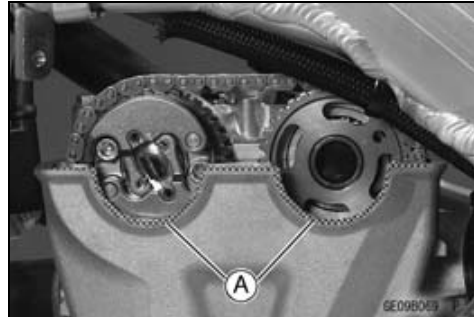

- Replace the head cover gasket.
- Install the head cover gasket [A] on the cylinder head.
- Install the spark plug hole gasket.



- Make sure that the upper chain guide [A] is bottomed.

CAUTION

Unless the upper chain guide is bottomed, the camshaft chain could push the cylinder head cover upward, leading to an oil leak.

- Install the head cover from the motorcycle left side.

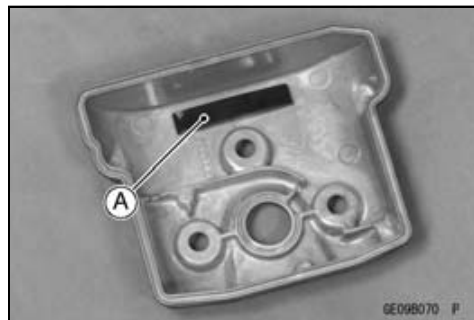

- Install the head cover bolt washers [A] with the metal side upwards.
- Tighten the cover bolt [B].
Torque - Cylinder Head Cover Bolt: 9.8 N·m (1.0 kgf·m, 87 in·lb)
- Install the spark plug cap.
- Pull up the spark plug cap lightly to make sure of the installation of the spark plug cap.



Camshaft Chain Tensioner

Camshaft Chain Tensioner Removal

CAUTION

This is a non-return type camshaft chain tensioner. The push rod does not return to its original position once it moves out to take up camshaft chain slack. Observe all the rules listed below:

When removing the tensioner, do not take out the mounting bolts only halfway. Retightening the mounting bolts from this position could damage the tensioner and the camshaft chain. Once the bolts are loosened, the tensioner must be removed and reset as described in "Camshaft Chain Tensioner Installation".

Do not turn over the crankshaft while the tensioner is removed. This could upset the camshaft chain timing and damage the valves.

- Loosen the cap bolt [A]
- Remove the tensioner mounting bolts [B], and remove the chain tensioner body [C].

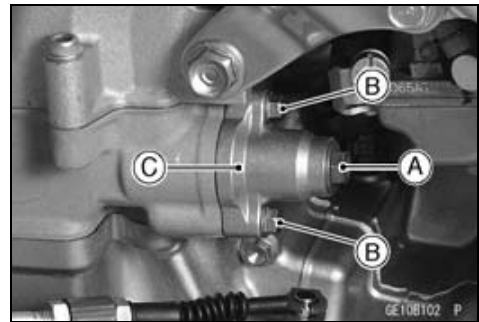

Camshaft Chain Tensioner Installation

- Remove the tensioner cap bolt and O-ring.
- While compressing the push rod [A], turn it clockwise with a suitable screwdriver until the rod stopped.

CAUTION

Do not turn the rod counterclockwise at installation. This could detach the rod and the tensioner cannot be reinstalled.

- While holding the rod in position with a suitable push rod holder plate [A] install the tensioner on the cylinder block.

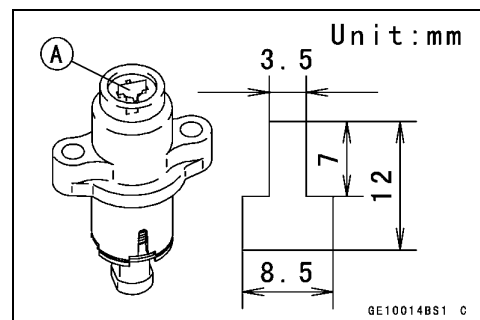

5-14 ENGINE TOP END

Camshaft Chain Tensioner

- Replace the chain tensioner gasket with a new one.
- Tighten:
 - Torque - Chain Tensioner Mounting Bolts [A]: 9.8 N·m (1.0 kgf·m, 87 in·lb)**
- Take out the holder plate [B].
- Install the O-ring and tighten the cap bolt.
 - Torque - Chain Tensioner Cap Bolt: 5.0 N·m (0.51 kgf·m, 44 in·lb)**

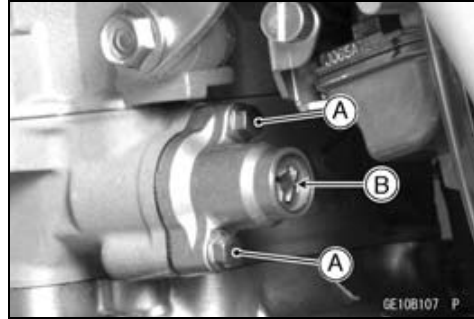

Camshaft

Camshaft Removal

- Remove:
 - Cylinder Head Cover (see Cylinder Head Cover Removal)
 - Timing Inspection Plug [A]
 - Balancer Shaft Plug [B]

Special Tool - Filler Cap Driver: 57001-1454

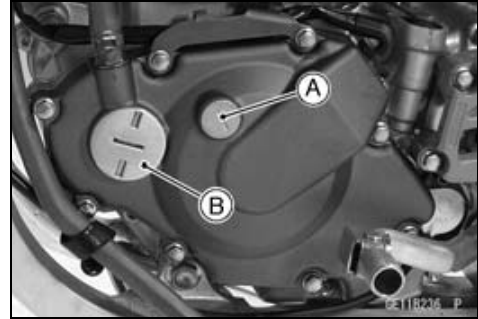

- First, bring the piston to the TDC (of either the compression or exhaust stroke).
- Place a wrench over the balancer weight nut and turn it counterclockwise to align the TDC mark [A] with the center of the groove [B] of the inspection hole.

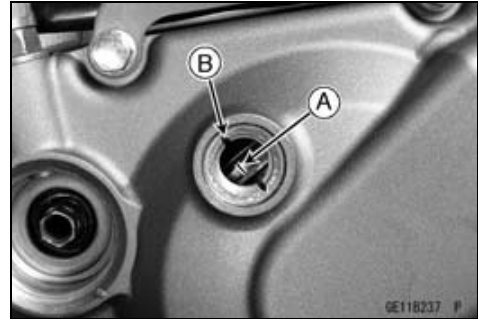

- Remove:
 - Camshaft Chain Tensioner (see Camshaft Chain Tensioner Removal).
 - Camshaft Cap Bolts [1 ~ 8] (sequence numbers)
 - Camshaft Caps [A] (together with the oil pipe [B])
- Plug the oil passage and camshaft chain tunnel with a clean cloth for prevent the oil pipe from dropping into the crankcase.
- While keeping parallel, remove the camshaft caps and oil pipes.

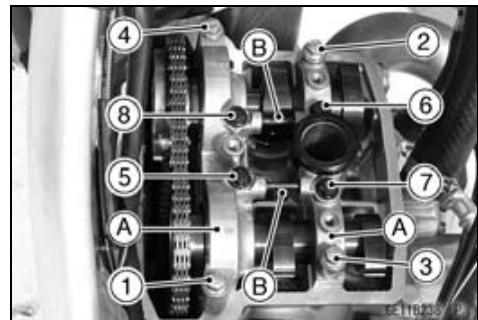

- Remove:
 - Positioning Rings [A]
- Disengage the Camshafts [B] from camshaft chain [C].

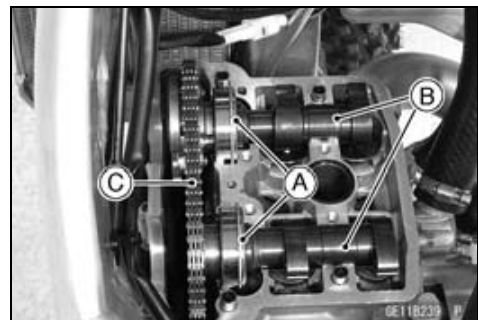

- Staff a clean cloth into the camshaft chain tunnel to keep any parts from dropping into the crankcase.

CAUTION

The crankshaft may be turned while the camshafts are removed.

Always pull the chain taut while turning the crankshaft. This avoids kinking the chain on the lower (crankshaft) sprocket. A kinked chain could damage both the chain and the sprocket.

5-16 ENGINE TOP END

Camshaft

- Remove:
 - Bolt [A]
 - Auto-Decompressor [B] (with the sprocket)

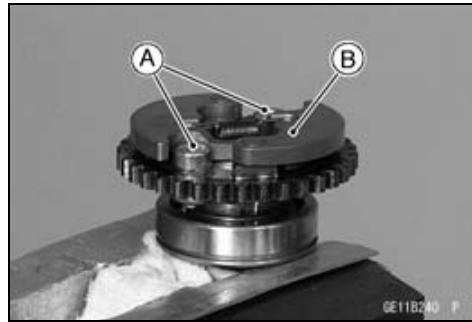

- Remove:
 - Circlips [A]

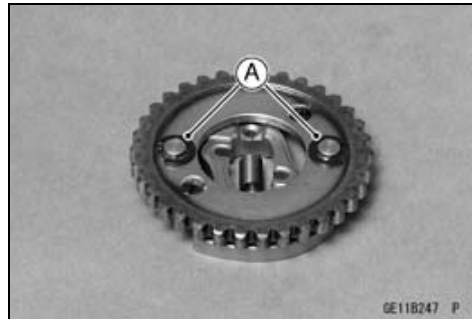

Camshaft Installation

- Assemble the auto-decompressor weights [A] and spring [B] to install it to the sprocket [C].
- Replace the circlips [D] with new ones, and install them.
- Apply a non-permanent locking agent to camshaft sprocket bolts.
- Fit the recess [E] of the weight and projection [F] of the camshaft, and install it.

Torque - Camshaft Sprocket Bolt [G]: 12 N·m (1.2 kgf·m, 104 in·lb)

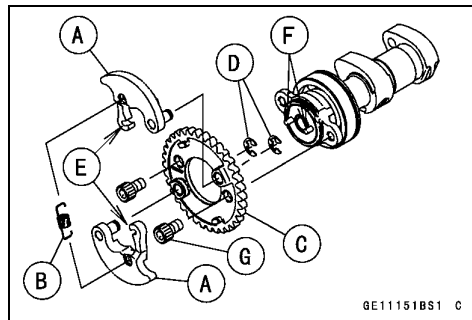

- Apply molybdenum disulfide oil to the ball bearing, all cam and journal surfaces of the camshaft.
- If the camshaft is replaced with a new part, apply a thin coat of molybdenum disulfide grease to the cam and journal surfaces.
- First, bring the crankshaft to the TDC (of either the compression or exhaust stroke).
- Place a wrench over the balancer weight nut and turn it counterclockwise to align the TDC mark [A] with the center of the groove [B] of the inspection hole.

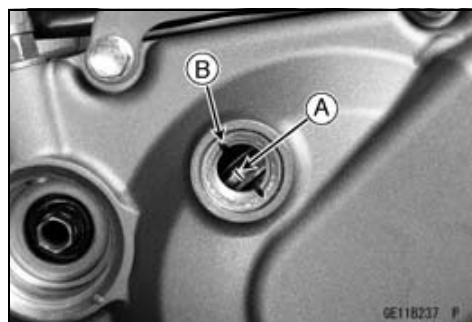

Camshaft

- Engage the camshaft chain with the camshaft sprockets.
- Pull the tension side (exhaust side) of the chain taut to install the chain.
- The timing marks on the sprocket must be aligned with the cylinder head upper surface.
- Pull the chain taut and fit it onto the camshaft sprocket.
- Starting with the timing mark on the front of the exhaust sprocket, count to the 1st pin. Feed the exhaust camshaft through the chain and align the 29th pin with the timing mark on the inlet camshaft sprocket.

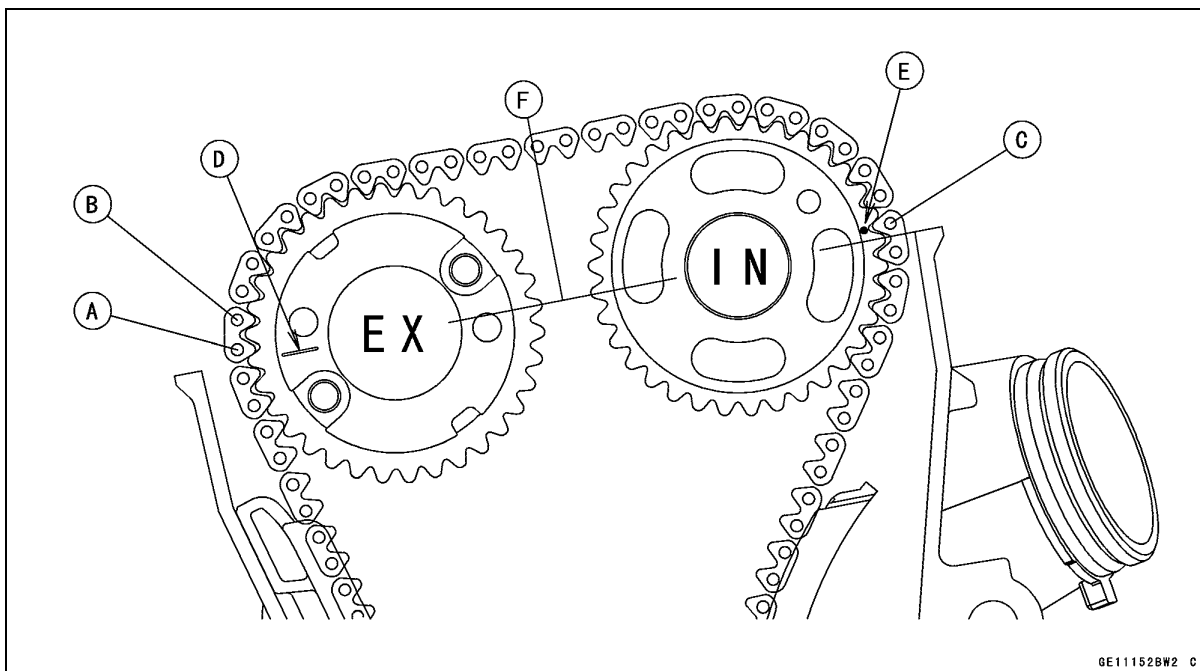

1st Pin [A]
2nd Pin [B]
29th Pin [C]

Mark (exhaust) [D]
Punch Mark (inlet) [E]
Upper Cylinder Head Surface [F]

- Plug the oil passage and camshaft chain tunnel with a clean cloth for prevent the any parts from dropping in the crankcase.
- Be sure to install the positioning rings [A] and dowel pins [B].

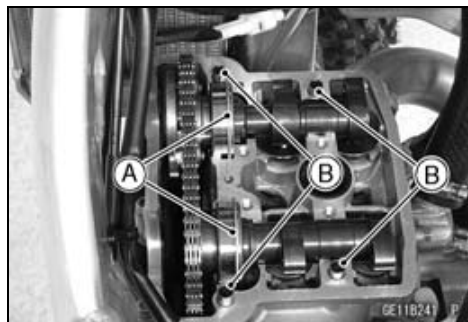

5-18 ENGINE TOP END

Camshaft

- Apply grease to the rubber portions of the oil pipes.
- Assemble:
 - Camshaft Caps [A]
 - Oil Pipes [B]
- While keeping the camshaft caps parallel, install them.

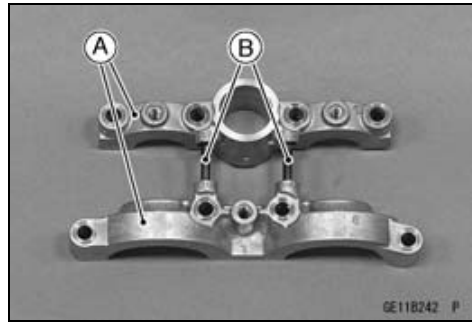

- Uniformly tighten all bolts and after the camshaft has settled, uniformly tighten all the bolts.
- Following the sequence numbers on the camshaft caps. Tighten the cap bolts [1 ~ 8] after applying molybdenum disulfide oil to the thread of them.

Torque - Camshaft Cap Bolts: 9.8 N·m (1.0 kgf·m, 87 in·lb)

- Install the camshaft chain tensioner (see Camshaft Chain Tensioner Installation), then, check the camshaft chain timing.

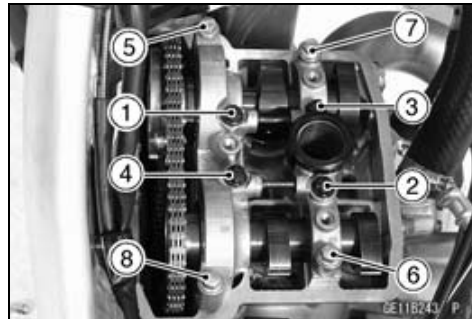

CAUTION

After this procedure, if any resistance is felt while turning over the crankshaft, stop immediately, and check the camshaft chain timing. Valves will be bent if the timing is not properly set.

- Install the cylinder head cover (see Cylinder Head Cover Installation), timing inspection cap, and the balancer shaft cap.

Special Tool - Filler Cap Driver: 57001-1454

Camshaft Chain Removal

- Remove:
 - Camshaft (see Camshaft Removal)
 - Flywheel (see Flywheel Removal in the Electrical System)
 - Lower Camshaft Chain Guide Bolt [A]
 - Lower Chain Guide [B]
 - Front Chain Guide [C]
- Remove the camshaft chain [D] from the crankshaft sprocket.

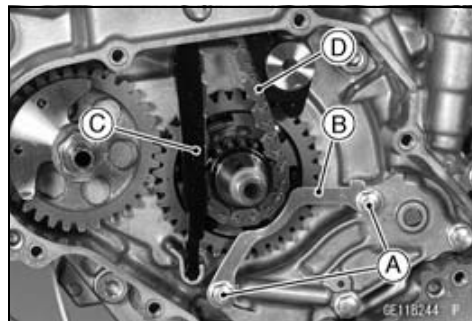

Camshaft Chain Installation

- Hang the camshaft chain [A] to the crankshaft sprocket.
- Install:
 - Front Chain Guide [B]
 - Lower Chain Guide [C]
- Tighten:
 - Torque - Lower Camshaft Chain Guide Bolts [D] (Oil Pump (Scavenge) Cover Bolts): 9.8 N·m (1.0 kgf·m, 87 in·lb)**
- Install:
 - Flywheel (see Flywheel Installation in the Electrical System chapter)
 - Camshaft (see Camshaft Installation)

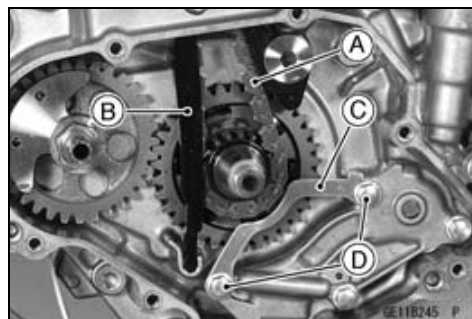

Camshaft

Camshaft and Camshaft Cap Wear Inspection

- Measure each clearance between the camshaft journal and camshaft cap using plastigauge (press gauge) [A].
- Install the camshaft caps (see Camshaft Installation)

NOTE

○ Do not turn the camshaft when the plastigauge is between the journal and camshaft cap.

- ★ If any clearance exceeds the service limit, measure the diameter of each camshaft journal with a micrometer.

Camshaft Bearing Clearance

Standard: 0.020 ~ 0.062 mm (0.00079 ~ 0.0024 in.)

Service Limit: 0.15 mm (0.0059 in.)

- ★ If the camshaft journal diameter is less than the service limit, replace the camshaft with a new one and measure the clearance again.

Camshaft Journal Diameter

Standard: 22.959 ~ 22.980 mm (0.90390 ~ 0.90472 in.)

Service Limit: 22.93 mm (0.9027 in.)

- ★ If the clearance still remains out of the service limit, replace the cylinder head unit.

Camshaft Runout Inspection

- Remove the camshaft (see Camshaft Removal).
- Set the camshaft in a camshaft alignment jig or on V blocks.
- Measure the runout with a dial gauge at the specified place as shown.
- ★ If the runout exceeds the service limit, replace the camshaft.

Camshaft Runout

Standard: TIR 0.02 mm (0.0008 in.) or less

Service Limit: TIR 0.1 mm (0.004 in.)

Cam Wear Inspection

- Remove the camshaft (see Camshaft Removal).
- Measure the height [A] of each cam with a micrometer.
- ★ If the cams are worn down past the service limit, replace the camshaft.

Cam Height

Standard:

Exhaust 36.943 ~ 37.057 mm (1.4544 ~ 1.4589 in.)

Inlet 37.743 ~ 37.857 mm (1.4859 ~ 1.4904 in.)

Service Limit:

Exhaust 36.84 mm (1.450 in.)

Inlet 37.64 mm (1.482 in.)

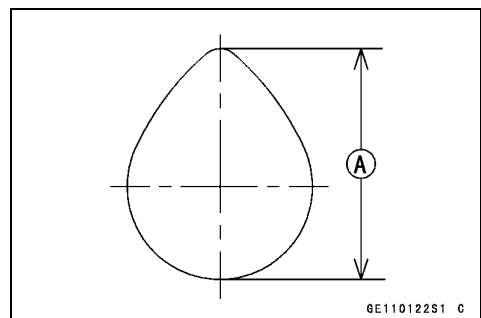
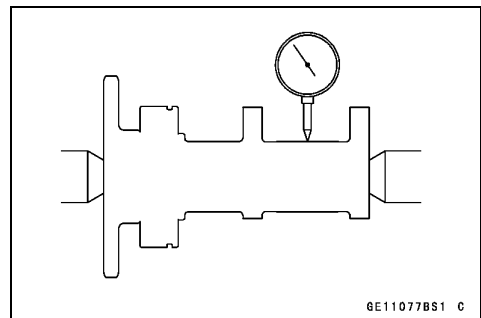
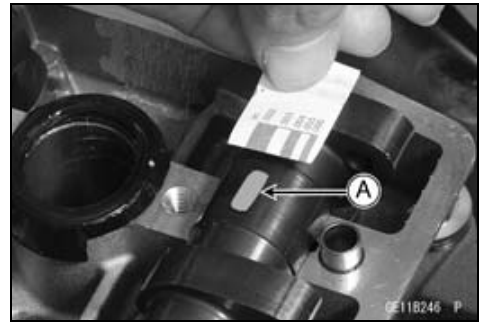

5-20 ENGINE TOP END

Cylinder Head

Cylinder Compression Measurement

- Start the engine.
- Thoroughly warm up the engine so that the engine oil between the piston and cylinder wall will help seal compression as it does during normal running.
- Stop the engine.
- Remove:
 - Fuel Tank (see Fuel Tank Removal in the Fuel System chapter)
- Remove the spark plug [A] with spark plug wrench [B] (or owner's tool).

Special Tool - Spark Plug Wrench, Hex 16: 57001-1262

Owner's Tool - Spark Plug Wrench: 92110-1172

- Attach the compression gauge [A] and the adapter hose [B] firmly into the spark plug hole.
- With the throttle fully open, turn the engine over sharply with the kickstarter several times until the compression gauge stops rising; the compression is the highest reading obtainable.

Special Tools - Compression Gauge: 57001-221

**Compression Gauge Adapter, M10 × 1.0:
57001-1317**

Cylinder Compression

**Service Range: 450 ~ 750 kPa (4.59 ~ 7.65 kg/cm², 65.2
~ 109 psi) @ 5 kicks**

- Install the spark plug.
 - **Torque - Spark Plug: 13 N·m (1.3 kgf·m, 113 in·lb)**
- Pull the spark plug cap lightly to make sure the installation of the spark plug cap.

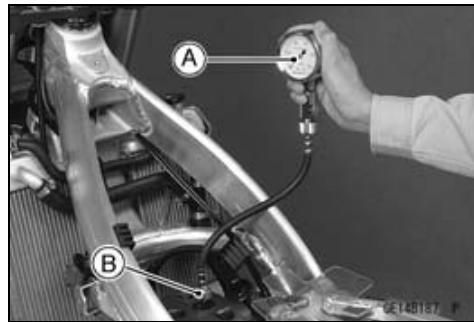
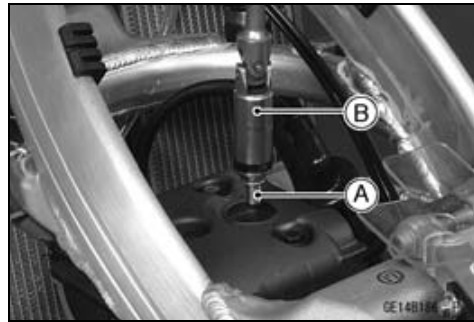

Cylinder Head

Problem	Diagnosis	Remedy (Action)
The cylinder compression is higher than the usable range	Carbon accumulation on piston and in cylinder head (combustion chamber) is suspected due to damaged valve stem or piston oil rings.	Remove the carbon deposits and replace damaged parts if necessary.
	Incorrect cylinder head gasket thickness.	Replace the gasket with a standard one.
	Damaged auto-decompressor spring or decompressor do not move smoothly.	Replace the spring or auto-decompressor.
The cylinder compression is lower than the usable range	Exhaust gas leakage around cylinder head.	Replace the damaged gasket and inspect cylinder head warp.
	Incorrect seating surface of valve.	Repair seating surface if possible.
	Valve clearance is too narrow.	Adjust the valve clearance.
	Piston/cylinder clearance is too wide.	Replace the piston and/or cylinder
	Piston seizure.	Inspect the cylinder and piston; repair or replace them if necessary.
	Bad condition of piston ring and/or piston ring grooves.	Replace the piston and/or the piston rings.
	Auto-decompressor do not move smoothly.	Replace the auto-decompressor.

Cylinder Head Removal

- Remove:
 - Fuel Tank (see Fuel Tank Removal in the Fuel System chapter)
 - Camshaft Chain Tensioner (see Camshaft Chain Tensioner Removal)
 - Cylinder Head Cover (see Cylinder Head Cover Removal)
 - Camshaft (see Camshaft Removal)
 - Carburetor (see Carburetor Removal in the Fuel System chapter)
 - Exhaust Pipe [A] (see Muffler Removal)
 - Clamp Screw [B]
 - Water Hose [C]
 - Engine Bracket Bolts [D]
 - Engine Bracket [E]

- Remove the 6 mm cylinder head bolts [A] and loosen the cylinder bolt [B].
- This prevents the 6 mm bolts from becoming damaged.

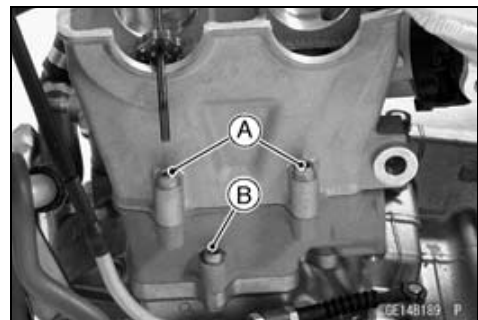
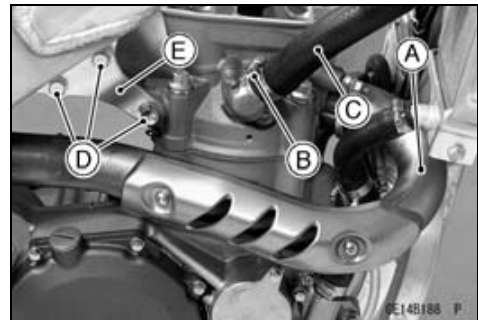

5-22 ENGINE TOP END

Cylinder Head

- Remove the 10 mm cylinder head bolts following the tightening sequence as shown.

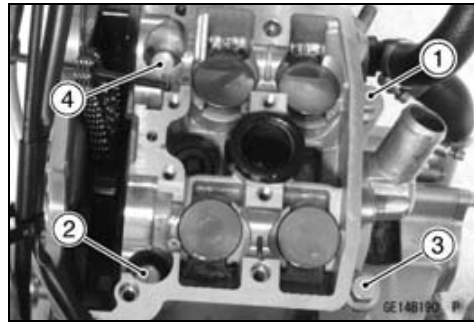

- Tap lightly up with a plastic mallet [A] to separate the cylinder head [B] from the cylinder.
- Remove the cylinder head gasket.

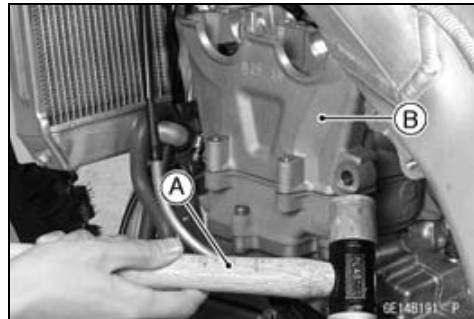

Cylinder Head Installation

- Fit the projection [A] of the front camshaft chain guide [B] in the groove [C] of the cylinder.
- Insert the guide end [D] into the recess [E] of the crankcase securely.

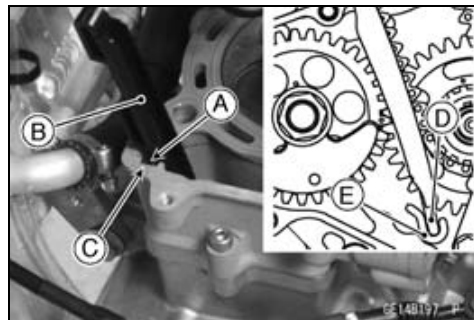

- Install:
 - Dowel Pins [A]
 - New Cylinder Head Gasket [B]
- Install the cylinder head.
- The camshaft caps are machined with the cylinder head; therefore, if a new cylinder head is installed, use the caps that are supplied with the new head.

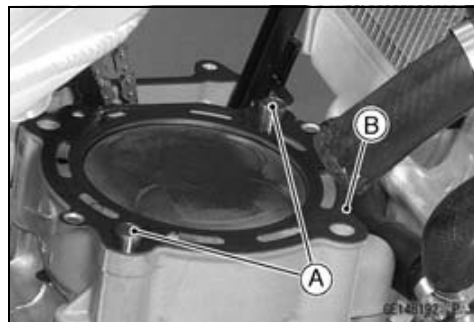

- Replace all the 10 mm cylinder head bolt washers with new ones.
- The 10 mm cylinder head bolt washers are copper-plated, and they could leak oil if reused.
- Apply molybdenum disulfide oil to the both sides [A] of the 10 mm cylinder head bolt washer and thread [B] of the 10 mm cylinder head bolts.

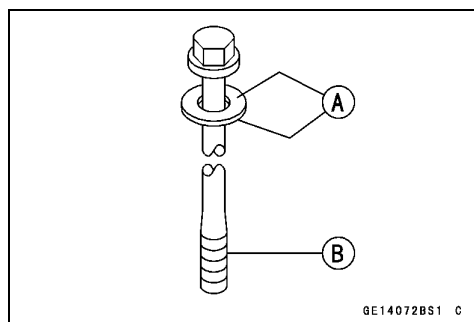

GE14072BS1 C

Cylinder Head

- Tighten the 10 mm cylinder head bolts in the numbered sequence [1 ~ 4].

Torque - Cylinder Head Bolts (M10): 59 N·m (6.0 kgf·m, 44 ft·lb)

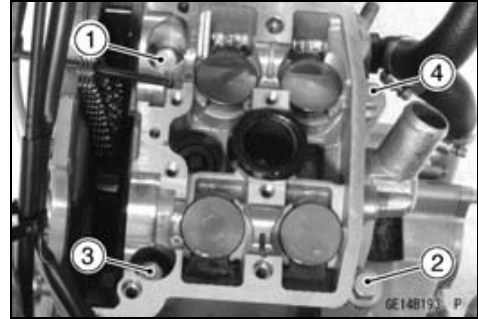

- Tighten:

Torque - Cylinder Bolt [A]: 12 N·m (1.2 kgf·m, 104 in·lb)
Cylinder Head Bolts (M6) [B]: 12 N·m (1.2 kgf·m, 104 in·lb)

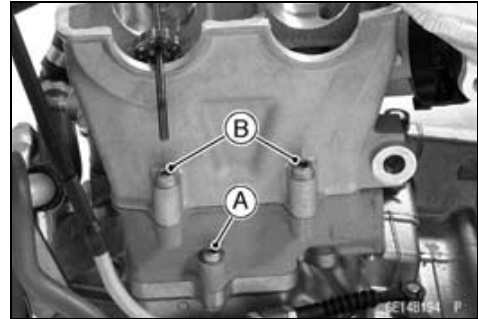

- Install:
 - Camshaft (see Camshaft Installation)
 - Cylinder Head Cover (see Cylinder Head Cover Installation)
 - Engine Bracket (see Engine Installation in the Engine Removal/Installation chapter)
- Connect the water hose, and tighten the hose clamp screw.
- Install:
 - Carburetor (see Carburetor Installation in the Fuel System chapter)
 - Exhaust Pipe (see Muffler Installation)
 - Fuel Tank (see Fuel Tank Installation in the Fuel System chapter)

Cylinder Head Cleaning

- Refer to the Cylinder Head Warp Inspection in the Periodic Maintenance chapter.

Cylinder Head Warp Inspection

- Refer to the Cylinder Head Warp Inspection in the Periodic Maintenance chapter.

5-24 ENGINE TOP END

Valves

Valve Clearance Inspection

- Refer to the Valve Clearance Inspection in the Periodic Maintenance chapter.

Valve Removal

- Remove the cylinder head (see Cylinder Head Removal).
- Remove the valve lifter and the shim from the valve.

NOTE

- Use the valve spring compressor assembly and the adapter to press down the valve spring retainer.

Special Tools - Valve Spring Compressor Assembly: 57001-241 [A]

Valve Spring Compressor Adapter, ϕ 24: 57001-1586 [B]

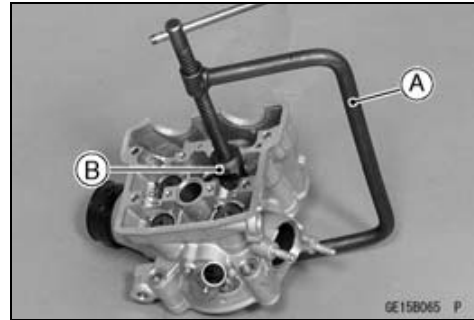

Valve Installation

CAUTION

Do not lap the valve to the valve seat, using the grinding compound. It will come off oxide film treated surface of the valve.

- Visually inspect the valve surface.
- ★ If the surface is damaged, replace it.
- Replace the oil seal [C] with a new part.
- Apply a thin coat of molybdenum disulfide grease to the valve stem [A] before installing the valve.
- Check to make sure that the valve moves up and down smoothly.
- Check to make sure that the valve and the valve seat are making proper contact.
- Install the inner valve spring [D] and outer valve spring [E] so that the closed coil end faces the spring seat [B].
- Compress the valve spring to install the split keepers [G] in order to secure the spring retainer [F] in place.

Special Tools - Valve Spring Compressor Assembly: 57001-241

Valve Spring Compressor Adapter, ϕ 24: 57001-1586

- The shim [H] must be installed with its thickness indication facing up towards the retainer.
- Apply high temperature grease to the shim or to the retainer to prevent the shim from falling off when the camshaft is being installed.
- Apply engine oil to the valve lifter [I] surface; then install the lifter.

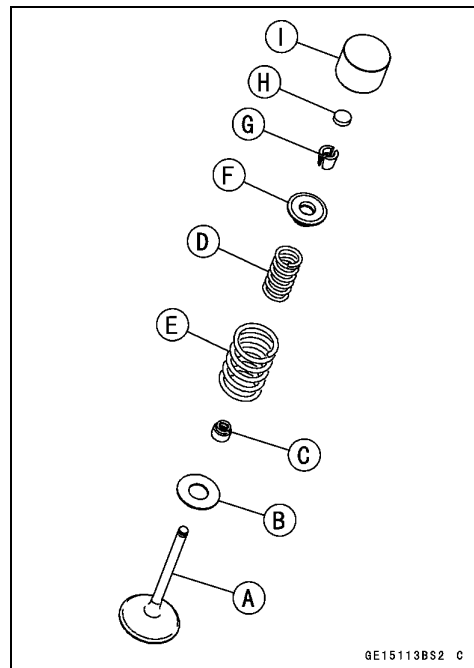

Valves

Valve Guide Removal

- Remove:
 - Valve (see Valve Removal)
 - Oil Seal
 - Spring Seat
- Heat the area around the valve guide up to 120 ~ 150°C (248 ~ 302°F).

CAUTION

Do not heat the cylinder head with a torch. This will warp the cylinder head. Soak the cylinder head and heat the oil.

- Hammer lightly on the valve guide arbor [A] to remove the guide.

Special Tool - Valve Guide Arbor, ϕ 5.5: 57001-1021

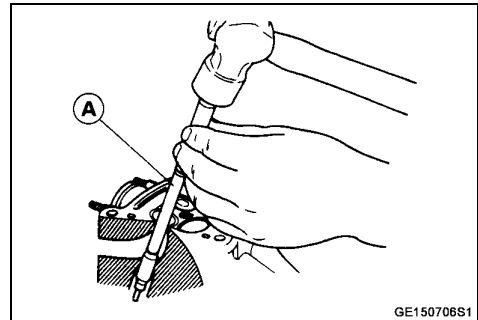

Valve Guide Installation

- Apply a thin coat of oil to the outer surface of the valve guide.
- Heat the area around the valve guide up to 120 ~ 150°C (248 ~ 302°F).

CAUTION

Do not heat the cylinder head with a torch. This will warp the cylinder head. Soak the cylinder head and heat the oil.

- Assemble the valve guide driver [A] and valve guide driver attachment D [B].

Special Tools - Valve Guide Driver, ϕ 4.5: 57001-1564
Valve Guide Driver Attachment D: 57001-1659

- When install the exhaust valve guide, using the attached washer (t = 2.0) [C].
- Using the valve guide driver, press and insert the valve guide in until the valve guide driver surface [D] touches the head surface.

[E] Exhaust 11.1 ~ 11.3 mm (0.437 ~ 0.445 in.)

[F] Inlet 13.1 ~ 13.3 mm (0.516 ~ 0.524 in.)

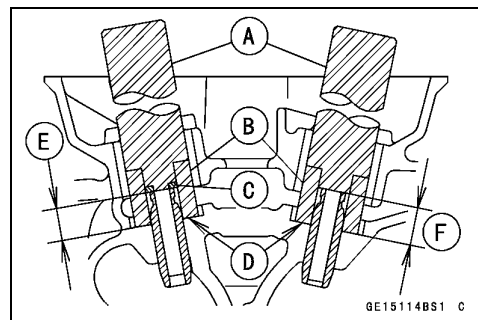

5-26 ENGINE TOP END

Valves

- Ream the valve guide with valve guide reamer [A], even if the old guide is reused.

Special Tool - Valve Guide Reamer, ϕ 5.5: 57001-1079



Valve/Valve Guide Clearance Measurement (Wobble Method)

- If a small bore gauge is not available, inspect the valve guide wear by measuring the valve/valve guide clearance with the wobble method as indicated below.
 - Insert a new valve [A] into the guide [B] and set a dial gauge against the stem perpendicular to it as close as possible to the cylinder head mating surface.
 - Move the stem back and forth [C] to measure the valve wobble.
- Repeat the measurement in a direction at a 90° angle to the first measurement.
 - ★ If the reading exceeds the service limit, replace the guide.

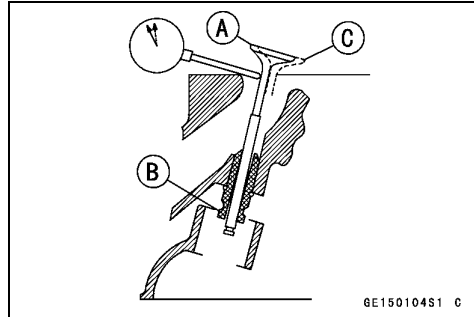

NOTE

- *The reading is greater than the actual valve/valve guide clearance because the measurement is taken outside of the guide.*

Valve/Valve Guide Clearance Measurement (Wobble Method)

Standard:

Exhaust	0.09 ~ 0.16 mm (0.0035 ~ 0.0063 in.)
Inlet	0.06 ~ 0.14 mm (0.0024 ~ 0.0055 in.)

Service Limit:

Exhaust	0.36 mm (0.014 in.)
Inlet	0.33 mm (0.013 in.)

Valves

Valve Seat Inspection

- Remove the valve (see Valve Removal).
- Check the valve seating surface [A] between the valve [B] and valve seat [C].
- Measure the outside diameter [D] of the seating pattern on the valve seat.
- ★ If the outside diameter is too large or too small, repair the seat. (see Seat Repair)

Valve Seating Surface Outside Diameter

Exhaust 30.4 ~ 30.6 mm (1.197 ~ 1.205 in.)

Inlet 35.4 ~ 35.6 mm (1.39 ~ 1.40 in.)

- Check the seating surface width of the valve seat.
- Measure the seat width [E] of the portion where there is no build-up carbon (white portion) of the valve seat with a vernier caliper.
- Good [F]

Valve Seating Surface Width Standard

Exhaust 0.8 ~ 1.2 mm (0.03 ~ 0.047 in.)

Inlet 0.5 ~ 1.0 mm (0.02 ~ 0.039 in.)

- ★ If the width is too wide [G], too narrow [H] or uneven [J], repair the seat (see Valve Seat Repair).

Valve Seat Repair

- For the instructions on how to use the valve seat cutter [A], follow the operation manual provided by the to manufacturer.

Special Tools - Valve Seat Cutter Holder, ϕ 5.5: 57001-1125 [B]

Valve Seat Cutter Holder Bar: 57001-1128

Exhaust: Valve Seat Cutter, 45° - ϕ 35: 57001-1116

Valve Seat Cutter, 32° - ϕ 35: 57001-1121

Valve Seat Cutter, 55° - ϕ 35: 57001-1247

Inlet: Valve Seat Cutter, 45° - ϕ 40: 57001-1496

Valve Seat Cutter, 32° - ϕ 38.5: 57001-1122

Valve Seat Cutter, 55° - ϕ 38.5: 57001-1497

- ★ If the tool manufacturer's instructions are not available, operate in accordance with the following procedure.

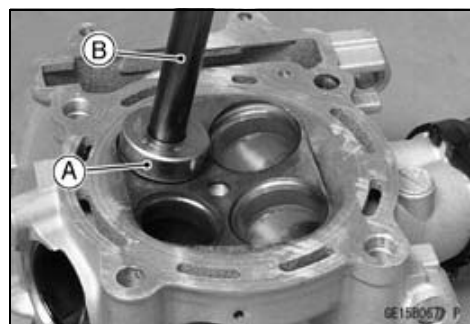
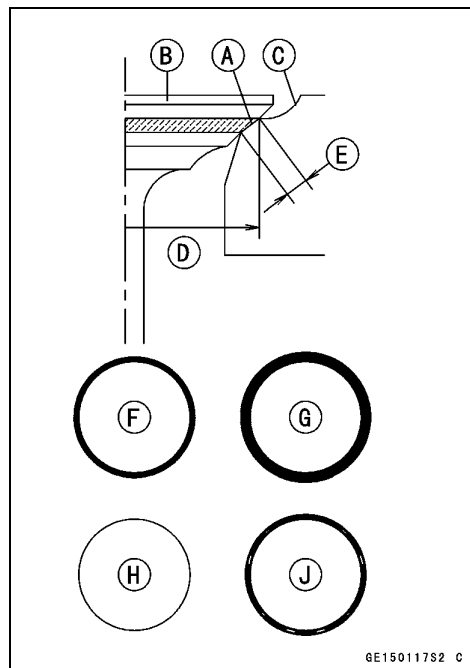

5-28 ENGINE TOP END

Valves

Seat Cutter Operation Care

1. This valve seat cutter is developed to grind the valve for repair. Therefore the cutter must not be used for other purposes than seat repair.
2. Do not drop or shock the valve seat cutter, or the diamond particles may fall off.
3. Do not fail to apply engine oil to the valve seat cutter before grinding the seat surface. Also wash off ground particles sticking to the cutter with washing oil.

NOTE

○Do not use a wire brush to remove the metal particles from the cutter. It will take off the diamond particles.

4. Setting the valve seat cutter holder in position, operate the cutter in one hand. Do not apply too much force to the diamond portion.

NOTE

○Prior to grinding, apply engine oil to the cutter and during the operation, wash off any ground particles sticking to the cutter with washing oil.

5. After use, wash it with washing oil and apply thin layer of engine oil before storing.

Marks Stamped on the Cutter

The marks stamped on the back of the cutter [A] represent the following.

- 60° Cutter Angle [B]
37.5φ Cutter Outer Diameter [C]

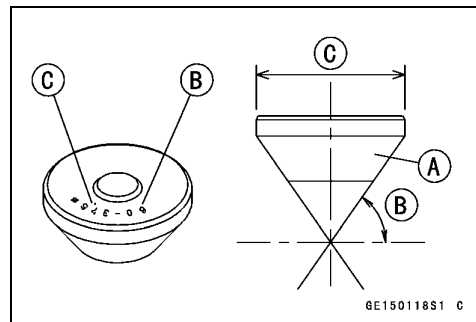

Repair Operating Procedures

- Clean the seat area carefully.
- Coat the seat with machinist's dye.
- Fit a 45° cutter into the holder and slide it into the valve guide.
- Press down lightly on the handle and turn it right or left. Grind the seating surface only until it is smooth.

CAUTION

Do not grind the seat too much. Overgrinding will reduce valve clearance by sinking the valve into the head. If the valve sinks too far into the head, it will be impossible to adjust the clearance, and the cylinder head must be replaced.

- Widened Width [A] of engagement by machining with 45° cutter
Ground Volume [B] by 32° cutter
32° [C]
Correct Width [D]
Ground Volume [E] by 55° cutter
55° [F]

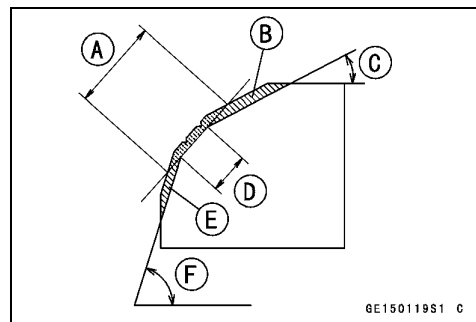

Valves

- Measure the outside diameter [O.D.] of the seating surface with a vernier caliper.
- ★ If the outside diameter of the seating surface is too small, repeat the 45° grind until the diameter is within the specified range.

Original Seating Surface [B]

- Remove all pittings or flaws from 45° ground surface.
- Alter grinding with 45° cutter, apply thin coat of machinist's dye to 45° [A] seating surface. This makes seating surface distinct and 32° and 55° grinding operation easier.
- When the valve guide is replaced, be sure to grind with 45° cutter for centering and good contact.

- ★ If the outside diameter [A] of the seating surface is too large, make the 32° grind described below.

- ★ If the outside diameter of the seating surface is within the specified range, measure the seat width as described below.

- Grind the seat at a 32° angle [B] until the seat O.D. is within the specified range.

- To make the 32° grind, fit a 32° cutter into the holder, and slide it into the valve guide.

- Turn the holder one turn at a time while pressing down very lightly. Check the seat after each turn.

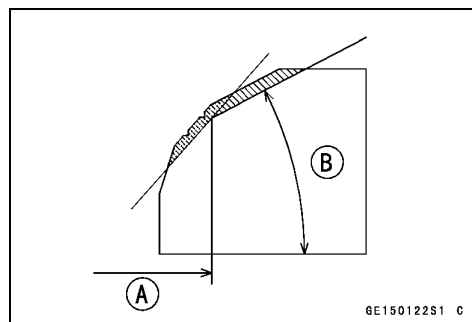
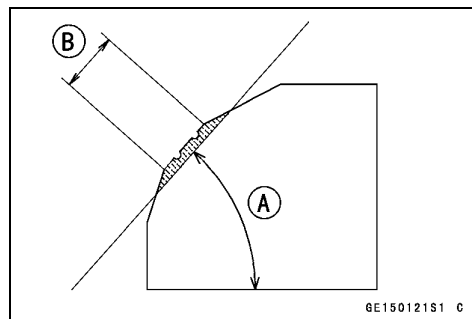

CAUTION

The 32° cutter removes material very quickly. Check the seat outside diameter frequently to prevent overgrinding.

- After making the 32° grind, return to the seat O.D. measurement step above.

- To measure the seat width, use a vernier caliper to measure the width of the 45° angle portion of the seat at several places around the seat.

- ★ If the seat width is too narrow, repeat the 45° grind until the seat is slightly too wide, and then return to the seat O.D. measurement step above.

- ★ If the seat width is too wide, make the 55° [A] grind described below.

- ★ If the seat width is within the specified range, lap the valve to the seat as described below.

- Grind the seat at a 55° angle until the seat width is within the specified range.

- To make the 55° grind, fit a 55° cutter into the holder, and slide it into the valve guide.

- Turn the holder, while pressing down lightly.

- After making the 55° grind, return to the seat width measurement step above.

Correct Width [B]

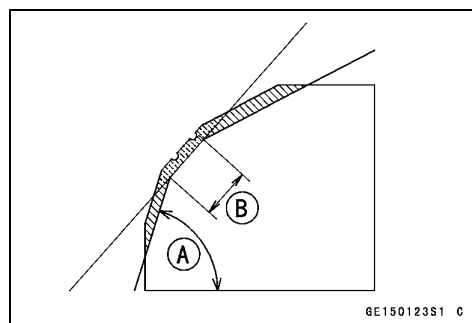

5-30 ENGINE TOP END

Valves

- The seating area should be marked about in the middle of the valve face.
- ★ If the seat area is not in the right place on the valve, check to be sure the valve is the correct part. If it is, it may have been refaced too much; replace it.
- When the engine is assembled, be sure to adjust the valve clearance (see Valve Clearance Adjustment in the Periodic Maintenance chapter).

Valves

Valve Seat Repair

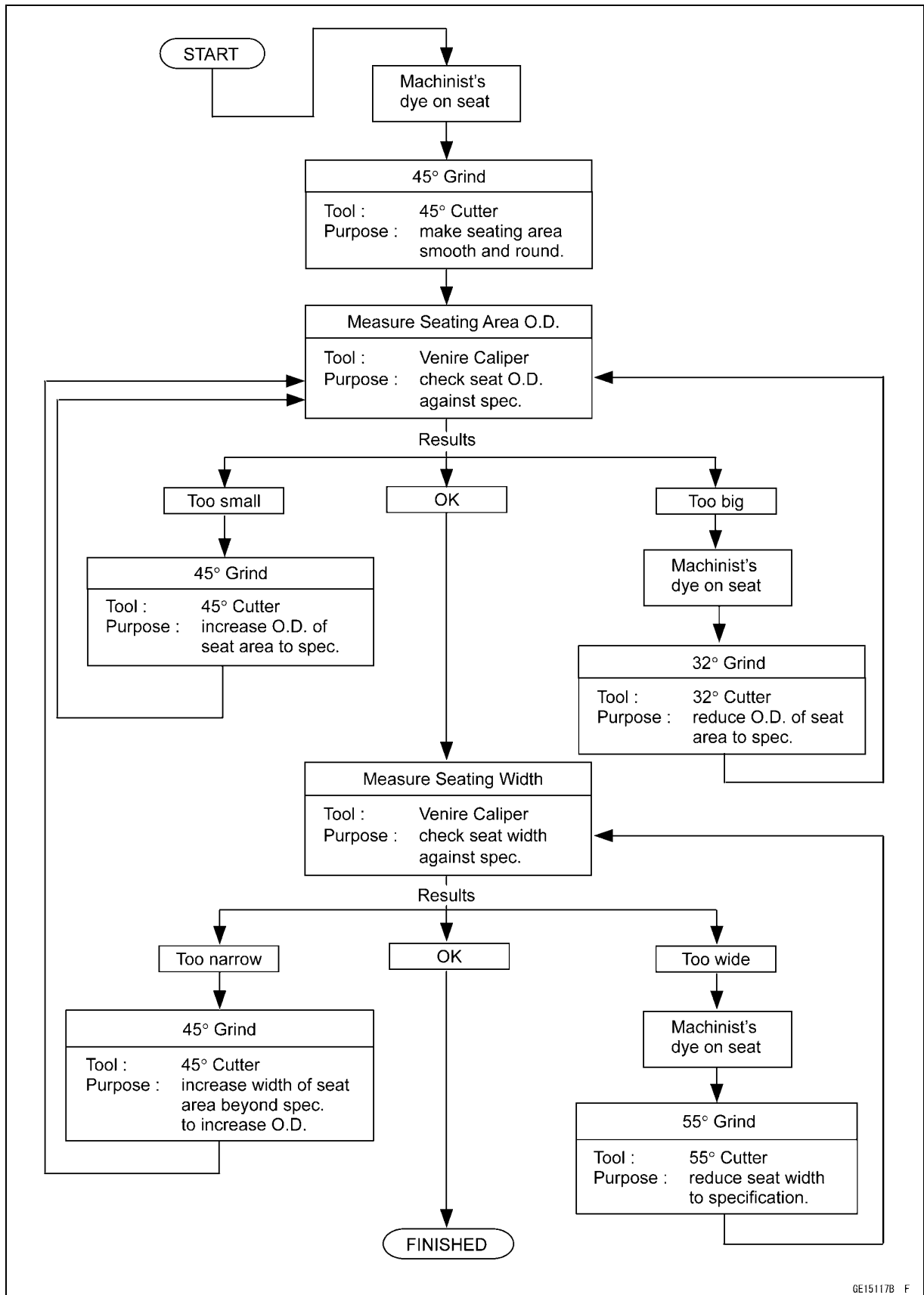

GE15117B F

5-32 ENGINE TOP END

Cylinder and Piston

Cylinder Removal

- Remove:
 - Cylinder Head (see Cylinder Head Removal)
 - Front Camshaft Chain Guide [A]
 - Cylinder Bolt [B]
- Tap lightly up with a plastic mallet to separate the cylinder from the crankcase.
- Remove the cylinder base gasket.

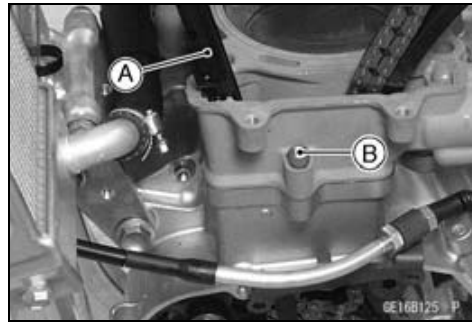

Piston Removal

- Remove the cylinder (see Cylinder Removal).
- Place a clean cloth under the piston and remove the piston snap ring [A] from one end of the piston pin.

CAUTION

Do not reuse snap rings, as removal weakens and deforms them. They could fall out and score the cylinder wall.



- Remove the piston pin, using a piston pin puller.
 - Special Tool - Piston Pin Puller Assembly: 57001-1568 [A]
- Remove the piston.



- Carefully spread the ring opening with your thumbs and then push up on the opposite side of the ring [A] to remove it.
- Remove the oil ring in the same procedure.

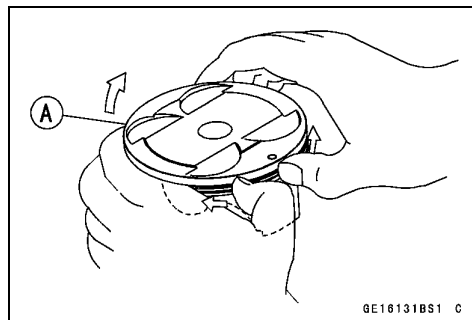

Cylinder and Piston Installation

NOTE

○The oil ring rails have no "top" or "bottom".

- Install the oil ring expander [A] in the bottom piston ring groove so the ends [B] butt together.
- Install the oil ring steel rails, one above the expander and one below it.
- Spread the rail with your thumbs, but only enough to fit the rail over the piston.
- Release the rail into the bottom piston ring groove.

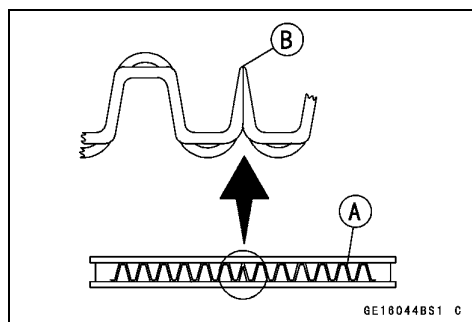

Cylinder and Piston

- Install the top ring [A] so that the "R" mark [B] faces up.

NOTE

○ If a new piston or cylinder is used, check piston to cylinder clearance (see *Piston/Cylinder Clearance*), and use new piston rings.

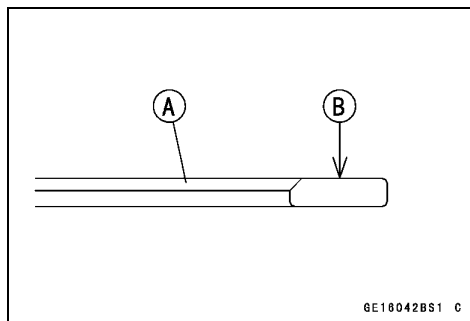

- Apply engine oil to the inside wall of the small end of the connecting rod.
- Face the circle mark [A] on the top of the piston must point toward the front [B] of the engine.

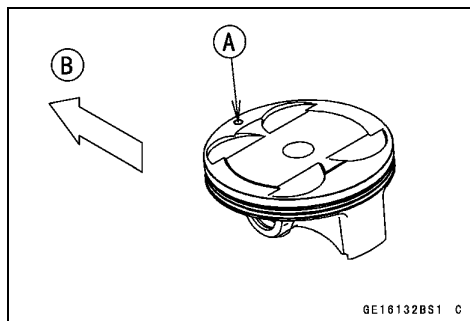

- Fit a new piston pin snap ring into the side of the piston so that the ring opening [A] does not coincide with the slit [B] of the piston pin hole.
- When installing the piston pin snap ring, compress it only enough to install it and no more.

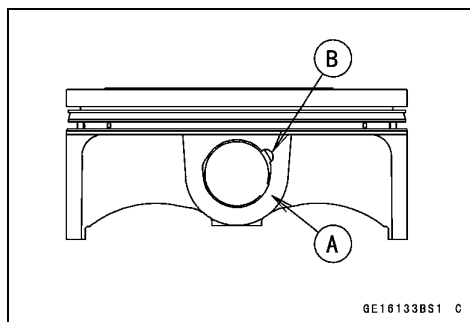

CAUTION

Do not reuse snap rings, as removal weakens and deforms them. They could fall out and score the cylinder wall.

- Install:
Dowel Pins [A]
New Cylinder Base Gasket [B]

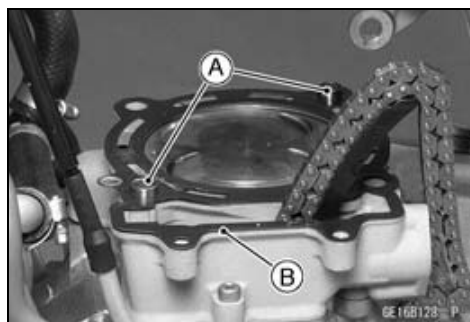

- The piston ring openings must be positioned as shown in the figure. The openings of the oil ring steel rails must be 20° of angle from the opening of the oil ring expander.
- Circle Mark [A]
- Top Ring [B]
- Upper Oil Ring Steel Rails [C]
- Oil Ring Expander [D]
- Lower Oil Ring Steel Rail [E]

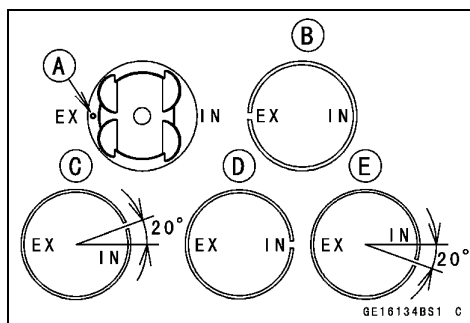

5-34 ENGINE TOP END

Cylinder and Piston

- Apply engine oil to the cylinder bore.
- Determine the position of the piston ring ends.
- Install the cylinder while compressing the piston rings with your fingers or the special tool [A].

Special Tools - Piston Ring Compressor Grip: 57001-1095
Piston Ring Compressor Belt, $\phi 95 \sim \phi 108$: 57001-1358

- Drive the front chain guide in.
- Install the removed parts.

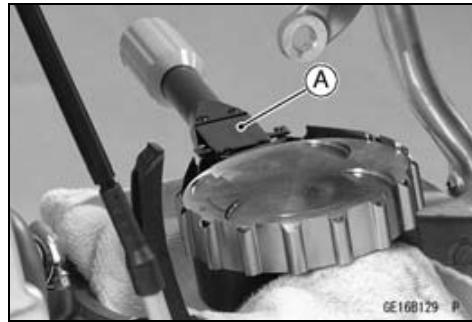

Cylinder Wear Inspection

- Refer to the Cylinder Wear Inspection in the Periodic Maintenance chapter.

Piston Wear Inspection

- Using a micrometer, measure the outside diameter [A] of each piston 8.5 mm (0.33 in.) [B] up from the bottom of the piston at a right angle to the direction of the piston pin.
- ★ If the piston's outside diameter is smaller than the service limit, replace the piston.

Piston Diameter

Standard: 95.970 ~ 95.980 mm (3.7783 ~ 3.7787 in.)

Service Limit: 95.82 mm (3.772 in.)

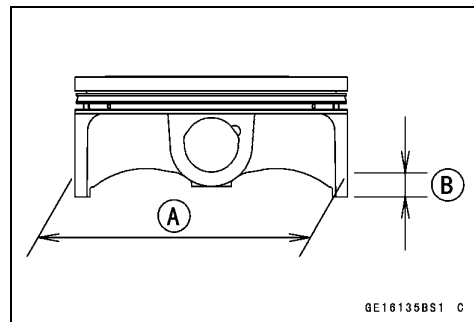

Piston/Cylinder Clearance Inspection

- Refer to the Piston/Cylinder Clearance Inspection in the Periodic Maintenance chapter.

Piston Ring/Ring Groove Clearance Inspection

- Check for uneven groove wear by inspecting the ring seating.
- ★ The rings should fit perfectly parallel to groove surfaces. If not, replace the piston and all the piston rings.
- With the piston rings in their grooves, make several measurements with a thickness gauge [A] to determine piston ring/groove clearance.

Piston Ring/Ring Groove Clearance

Standard:

Top 0.04 ~ 0.07 mm (0.002 ~ 0.003 in.)

Service Limit:

Top 0.17 mm (0.0067 in.)

- ★ If the piston ring groove clearance is greater than the service limit, measure the ring thickness and groove width as follows to decide whether to replace the rings, the piston or both.

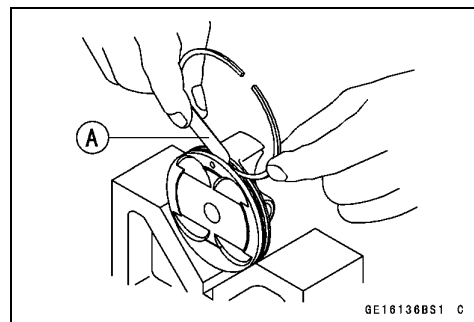

Cylinder and Piston

Piston Ring Groove Width Inspection

- Measure the groove width at several points around the piston with a vernier caliper.

Piston Ring Groove Width

Standard:

Top 1.03 ~ 1.05 mm (0.0406 ~ 0.0413 in.)

Service Limit:

Top 1.1 mm (0.043 in.)

- ★ If any of the groove widths exceeds the service limit, replace the piston.

Piston Ring Thickness Inspection

- Measure the thickness at several points around ring with a micrometer.

Piston Ring Thickness

Standard:

Top 0.970 ~ 0.990 mm (0.0381 ~ 0.0390 in.)

Service Limit:

Top 0.90 mm (0.035 in.)

- ★ If any of the measurements is less than the service limit on either of the rings, replace the rings as a set.

NOTE

○ When using new rings in a used piston, check for uneven groove wear. The rings should fit perfectly parallel to the groove sides. If not, replace the piston.

Piston Ring End Gap Measurement

- Place the piston ring [A] inside the cylinder, using the piston to locate the ring squarely in place. Place the piston ring close to the bottom of the cylinder, where cylinder wear is minimal
- Measure the gap [B] between the ends of the ring using a thickness gauge.
- ★ If the ring end gap exceeds the service limit, replace the ring.

Piston Ring End Gap

Standard:

Top 0.25 ~ 0.35 mm (0.0098 ~ 0.014 in.)

Oil 0.15 ~ 0.50 mm (0.0059 ~ 0.020 in.)

Service Limit:

Top 0.6 mm (0.02 in.)

Oil 0.8 mm (0.03 in.)

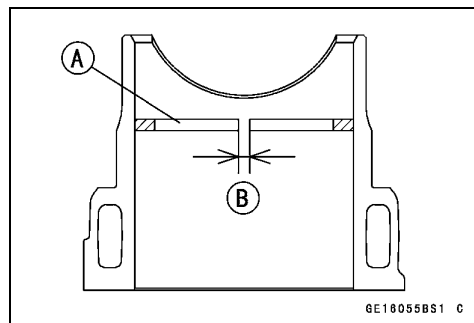

5-36 ENGINE TOP END

Cylinder and Piston

Piston, Piston Pin, Connecting Rod Wear Inspection

- Visually inspect the snap ring [A] still fitted in place.
- ★ If the ring shows weakness or deformation, replace the ring. Also if the pin hole groove shows excessive wear, replace the piston.
- Measure the diameter of the piston pin [B] with a micrometer.
- ★ If the piston pin diameter is less than the service limit at any point, replace the piston pin.
- Using a cylinder gauge, measure the diameter of both of piston pin holes [C] in the piston and the inside diameter of the connecting rod small end [D].
- ★ If either piston pin hole diameter exceeds the service limit, replace the piston.
- ★ If the connecting rod small end inside diameter exceeds the service limit, replace the connecting rod.

Piston Pin Diameter

Standard: 18.991 ~19.000 mm (0.74768 ~ 0.74803 in.)

Service Limit: 18.95 mm (0.7461 in.)

Piston Pin Hole Diameter

Standard: 19.004 ~ 19.010 mm (0.74819 ~ 0.74842 in.)

Service Limit: 19.08 mm (0.7512 in.)

Connecting Rod Small End Inside Diameter

Standard: 19.019 ~ 19.030 mm (0.74878 ~ 0.74921 in.)

Service Limit: 19.07 mm (0.7508 in.)

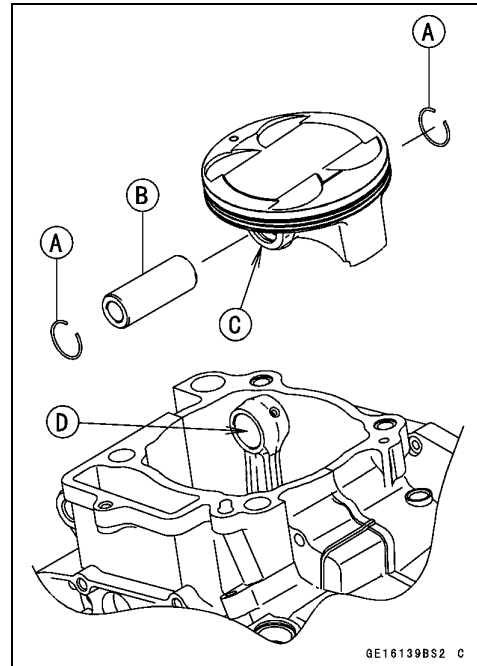

Carburetor Holder

Carburetor Holder Installation

- Fit the recess [A] of the holder on the projection [B] of the cylinder head.

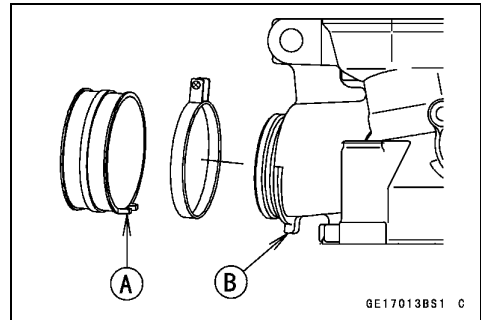

- The marked side [A] of the carburetor holder [B] face to the carburetor.

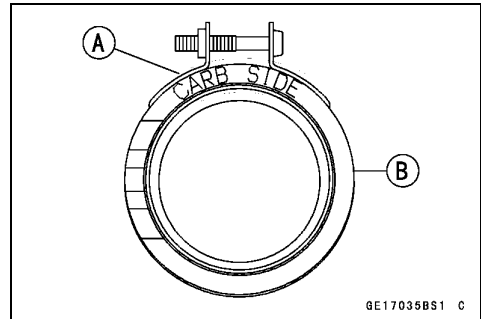

- When installing the clamp screws refer to the Cable, Wire, and Hose Routing in the Appendix chapter.

Torque - Carburetor Holder Clamp Screw: 2.0 N·m (0.20 kgf·m, 17 in·lb)

5-38 ENGINE TOP END

Muffler

⚠ WARNING

To avoid a serious burn, do not remove the muffler when the engine is still hot. Wait until the muffler cools down.

Muffler Removal

- Loosen the muffler clamp bolt [A].
- Remove the exhaust pipe holder nut [B].
- Remove the exhaust pipe [C].

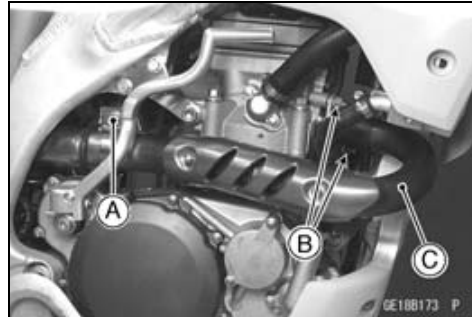

- Remove
Seat (see Seat Removal in the Frame chapter)
Right Side Cover (see Side Cover Removal in the Frame chapter)
- Remove the muffler mounting bolts [A].
- Remove the muffler [B] from the back.

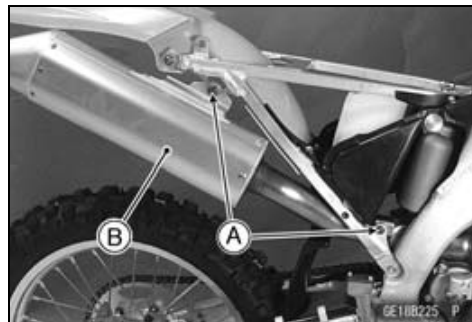

Muffler Installation

- Replace the holder gasket [A] with a new one.
- Check the gasket [B] at the clamp and replace it if it is damaged. Make sure that the gasket is placed securely outside the exhaust pipe.

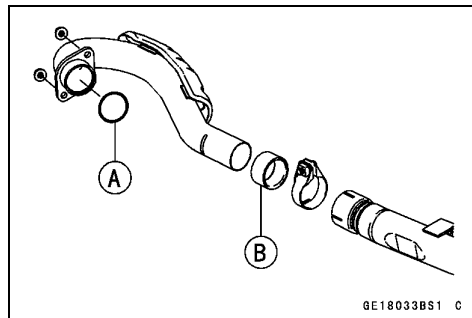

- Tighten the following bolts and nut according to the specific tightening sequence.

1. Exhaust Pipe Holder Nuts [A] (Temporary)
2. Muffler Mounting Bolts [B] (Temporary)
3. Muffler Mounting Bolts [C]

Torque - Muffler Mounting Bolts: 21 N·m (2.1 kgf·m, 15 ft·lb)

4. Muffler Mounting Bolts [B]

Torque - Muffler Mounting Bolts: 21 N·m (2.1 kgf·m, 15 ft·lb)

5. Exhaust Pipe Holder Nuts [A]

Torque - Exhaust Pipe Holder Nuts: 21 N·m (2.1 kgf·m, 15 ft·lb)

6. Muffler Clamp Bolt [D]

- Thoroughly warm up the engine, wait until the engine cools down, and then retighten the exhaust pipe holder nuts, and the clamp bolt securely.

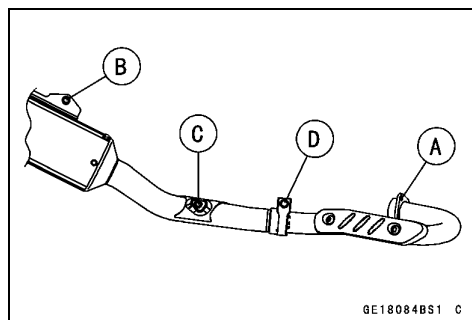

Muffler Baffle Replacement

- Refer to the Muffler Baffle Change in the Periodic Maintenance chapter.

Engine Right Side

Table of Contents

Exploded View	6-2
Specifications	6-6
Special Tools	6-7
Clutch Lever and Cable	6-8
Clutch Lever (Clutch Cable) Free Play Inspection	6-8
Clutch Lever (Clutch Cable) Free Play Adjustment	6-8
Clutch Lever Installation	6-8
Clutch Cable Removal	6-8
Clutch Cable Installation	6-9
Clutch Cable Inspection and Lubrication	6-9
Clutch Cover and Right Engine Cover	6-10
Clutch Cover Removal	6-10
Clutch Cover Installation	6-10
Right Engine Cover Removal	6-10
Right Engine Cover Installation	6-10
Release Shaft Removal	6-11
Release Shaft Installation	6-11
Clutch	6-12
Clutch Removal	6-12
Clutch Installation	6-12
Clutch Plate Assembly Free Play Inspection/Adjustment	6-15
Friction and Steel Plates Wear, Damage Inspection	6-15
Friction and Steel Plate Warp Inspection	6-15
Clutch Spring Free Length Inspection	6-15
Clutch Housing Finger Damage Inspection	6-16
Friction Plate/Clutch Housing Clearance Inspection	6-16
Clutch Hub Spline Damage Inspection	6-16
Primary Gear	6-17
Primary Gear Removal	6-17
Primary Gear Installation	6-17
External Shift Mechanism	6-18
External Shift Mechanism Removal	6-18
External Shift Mechanism Installation	6-18
External Shift Mechanism Inspection	6-20
Kickstarter	6-21
Kick Pedal Assy Removal	6-21
Kick Pedal Assy Installation	6-21
Kick Pedal Assy Disassembly	6-21
Kick Pedal Assy Assembly	6-21
Idle Gear Removal	6-21
Idle Gear Installation	6-22
Kickshaft Removal	6-22
Kickshaft Installation	6-22
Kick Shaft Assembly Disassembly/Assembly	6-23

6-2 ENGINE RIGHT SIDE

Exploded View

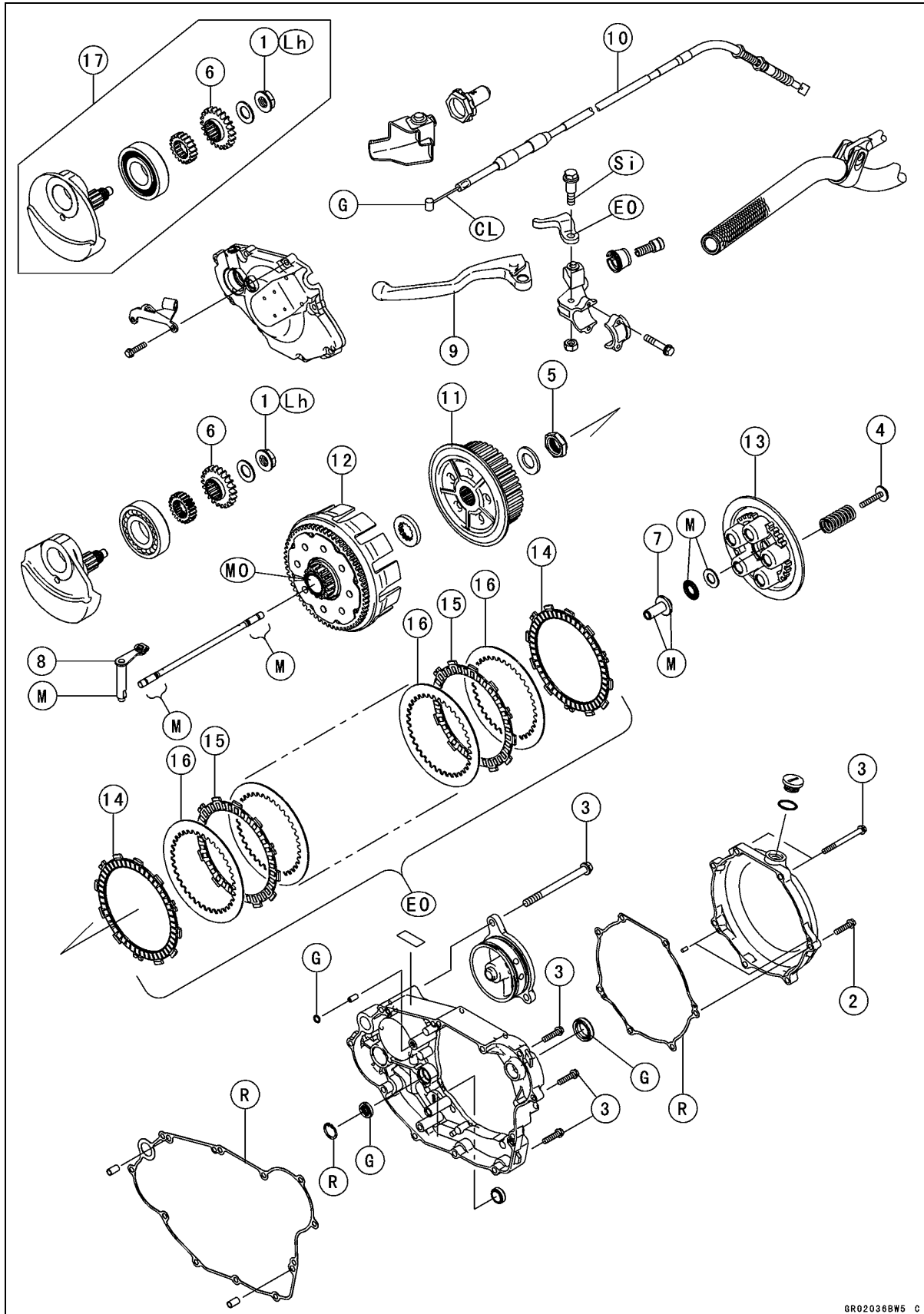

GR02036BWS C

Exploded View

No.	Fastener	Torque			Remarks
		N·m	kgf·m	ft·lb	
1	Primary Gear Nut	98	10	72	Lh
2	Clutch Cover Bolts	9.8	1.0	87 in·lb	
3	Right Engine Cover Bolts	9.8	1.0	87 in·lb	
4	Clutch Spring Bolts	8.8	0.90	78 in·lb	
5	Clutch Hub Nut	98	10	72	

- 6. Primary Gear
- 7. Push Rod Holder
- 8. Release Lever Shaft
- 9. Clutch Lever
- 10. Clutch Cable
- 11. Clutch Hub
- 12. Clutch Housing
- 13. Clutch Pressure Plate
- 14. Friction Plates (Number of the lining blocks are many.)
- 15. Friction Plates (Number of the lining blocks are little.)
- 16. Steel Plates
- 17. KX450D6F ~ D7F
- CL: Apply cable lubricant.
- EO: Apply engine oil.
- G: Apply grease.
- Lh: Left-hand threads
- M: Apply molybdenum disulfide grease.
- MO: Apply molybdenum disulfide oil.
- R: Replacement Parts
- Si: Apply silicone grease.

Exploded View

No.	Fastener	Torque			Remarks
		N·m	kgf·m	ft·lb	
1	Ratchet Guide Bolt	8.8	0.90	78 in·lb	L
2	Kick Pedal Bolt	25	2.5	18	L
3	Shift Pedal Bolt	9.8	1.0	87 in·lb	
4	Ratchet Plate Mounting Bolt	9.8	1.0	87 in·lb	S
5	Ratchet Plate Mounting Screw (KX450D6F)	6.4	0.65	56 in·lb	L, S
	Ratchet Plate Mounting Bolt (KX450D7F ~)	15	1.5	11	L, S
6	Gear Set Lever Nut	8.8	0.90	78 in·lb	
7	Shift Drum Cam Bolt	24	2.4	17	L

- 8. Kick Pedal
 - 9. Kickshaft Idle Gear
 - 10. Ratchet Gear
 - 11. Kick Gear
 - 12. Shift Pedal
 - 13. Ratchet Plate
 - 14. Ratchet Assembly
 - 15. Gear Set Lever
 - 16. Shift Drum Cam
 - 17. Shift Shaft
 - 18. KX450D6F
- EO: Apply engine oil.
G: Apply grease.
L: Apply a non-permanent locking agent.
M: Apply molybdenum disulfide grease.
R: Replacement Parts
St: Stake the fasteners.

6-6 ENGINE RIGHT SIDE

Specifications

Item	Standard	Service Limit
Clutch Lever		
Clutch Lever Free Play	8 ~ 13 mm (0.3 ~ 0.5 in.)	— — —
Clutch		
Friction Plate Thickness	2.92 ~ 3.08 mm (0.115 ~ 0.121 in.)	2.6 mm (0.10 in.)
Friction Plate Warp	0.15 mm (0.0059 in.) or less	0.3 mm (0.01 in.)
Steel Plate Warp	0.2 mm (0.008 in.) or less	0.3 mm (0.01 in.)
Clutch Spring Free Length	49.2 mm (1.94 in.)	46.7 mm (1.84 in.)
Friction Plate/Clutch Housing Clearance	0.20 ~ 0.60 mm (0.0079 ~ 0.024 in.)	0.8 mm (0.03 in.)
Clutch Plate Assembly Length	34.9 ~ 35.5 mm (1.37 ~ 1.40 in.)	— — —

Special Tools

Outside Circlip Pliers:
57001-144

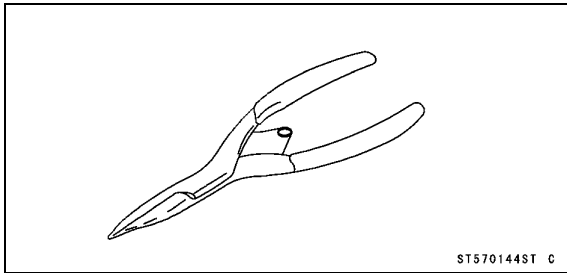

Gear Holder, m2.0:
57001-1557

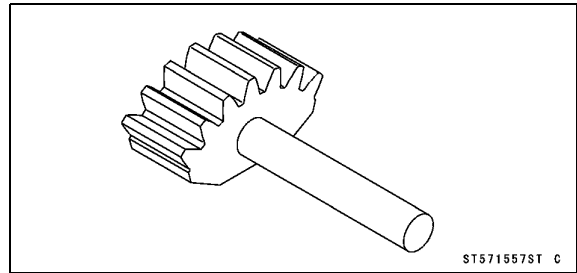

Clutch Holder:
57001-1243

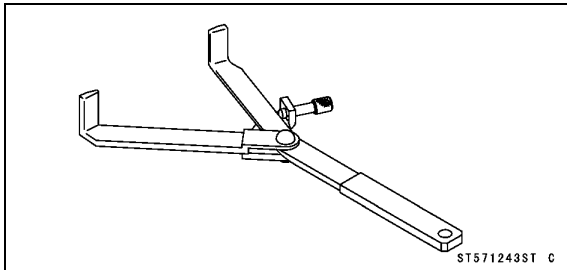

6-8 ENGINE RIGHT SIDE

Clutch Lever and Cable

Due to friction plate wear and clutch cable stretch over a long period of use, the clutch must be adjusted in accordance with the Periodic Maintenance Chart.

⚠ WARNING

To avoid a serious burn, never touch the hot engine or exhaust chamber during clutch adjustment.

Clutch Lever (Clutch Cable) Free Play Inspection

- Refer to the Clutch Lever (Clutch Cable) Free Play Check in the Periodic Maintenance chapter.

Clutch Lever (Clutch Cable) Free Play Adjustment

- Refer to the Clutch Lever Free (Clutch Cable) Play Adjustment in the Periodic Maintenance chapter.

Clutch Lever Installation

- Install the clutch lever [A] so that it incline $20^{\circ} \pm 5^{\circ}$ [B] more than the horizontal line [C], and position it from the edge of the grip to 170 mm (6.69 in.) [D].

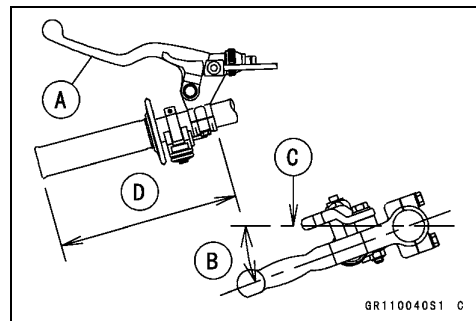

Clutch Cable Removal

- Turn in the adjuster fully [A].
- Slide the dust cover [A] out of place.
- Screw the adjuster [B] at the clutch lever fully.
- Line up the slots [C] in the clutch lever and adjuster and then free the cable from the lever.

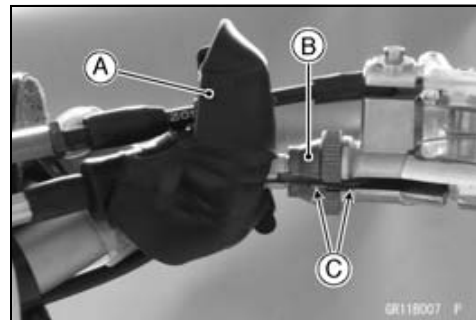

Clutch Lever and Cable

- Loosen the adjusting nuts [A] fully.
- Free the clutch inner cable tip [B] from the clutch release lever [C].

CAUTION

Do not remove the clutch release shaft unless it is absolutely necessary. If removed, release shaft oil seal must be replaced with a new one.

- Pull the clutch cable out of the frame.

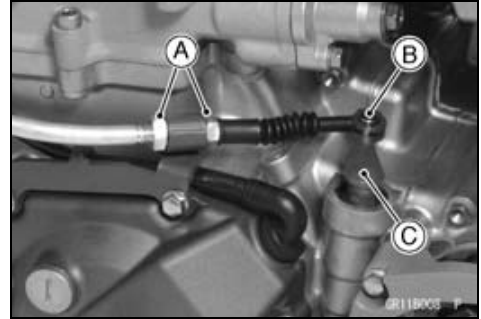

Clutch Cable Installation

- Run the clutch cable correctly (see Cable, Wire, and Hose Routing section in the Appendix chapter).
- Adjust the clutch cable (see Clutch Lever (Clutch Cable) Free Play Adjustment in the Periodic Maintenance chapter).

Clutch Cable Inspection and Lubrication

- During a periodic inspection or when the cable has been removed, inspect and lubricate the cable (see General Lubrication and Cable Inspection in the Periodic Maintenance chapter).

6-10 ENGINE RIGHT SIDE

Clutch Cover and Right Engine Cover

Clutch Cover Removal

- Drain the engine oil (see Engine Oil Change in the Periodic Maintenance chapter).
- Remove the brake pedal (see Brake Pedal Removal in the Brakes chapter).
- Remove the clutch cover bolts [A] and remove the clutch cover [B].

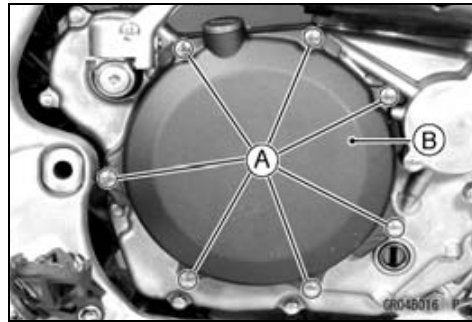

Clutch Cover Installation

- Replace the clutch cover gasket with a new one.
- Be sure to install the dowel pins.
- Apply a non-permanent locking agent to the brake pedal bolt.
- Install the clutch cover [A].

Torque - Clutch Cover Bolts [B]: 9.8 N·m (1.0 kgf·m, 87 ft·lb)

Right Engine Cover Bolts [C]: 9.8 N·m (1.0 kgf·m, 87 in·lb)

Brake Pedal Bolt: 25 N·m (2.5 kgf·m, 18 ft·lb)

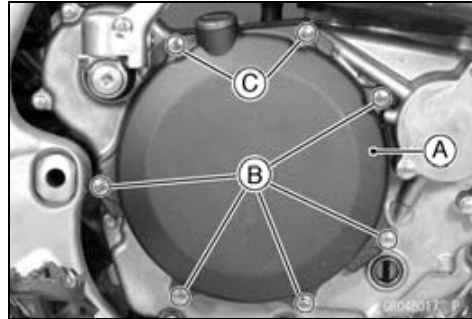

Right Engine Cover Removal

- Drain:
 - Engine Oil (see Engine Oil Change in the Periodic Maintenance chapter)
 - Coolant (see Coolant Draining in the Cooling System chapter)
- Remove:
 - Kick Pedal [A] (see Kick Pedal Removal)
 - Brake Pedal [B] (see Brake Pedal Removal in the Brakes chapter)
- Remove:
 - Engine Guard
 - Water Hose [A]
 - Right Engine Cover Bolts [B]
 - Right Engine Cover [C]

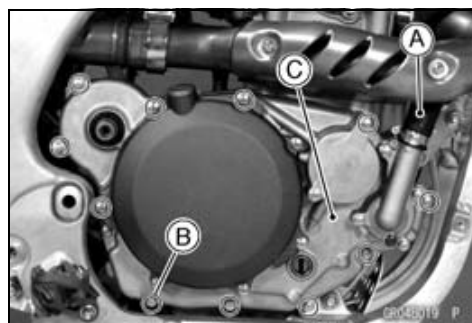
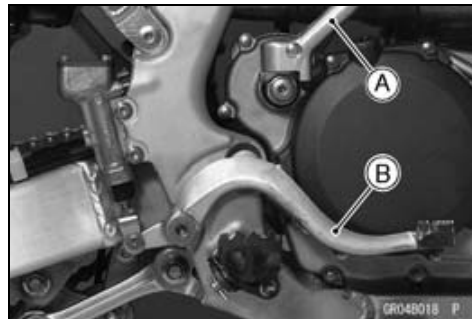

Right Engine Cover Installation

- Three dowel pins [A] are installed at the mating surface between the crankcase and the right engine cover.
- Apply grease to the O-rings [B], and install them to the crankcase.
- Install the lower O-ring so that the tapered side facing outside.
- Replace the engine cover gasket with a new one.
- Apply a high-temperature grease to the kick shaft oil seal lips and kick shaft spline.

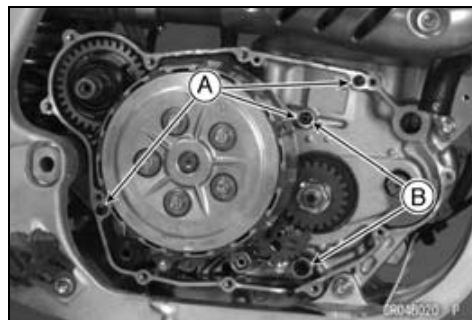

Clutch Cover and Right Engine Cover

- When installing the cover doesn't go well, the cover is installed according to the following procedures.
- Fit the water pump shaft [A] and groove [B] of the balancer shaft while turning the water pump shaft.

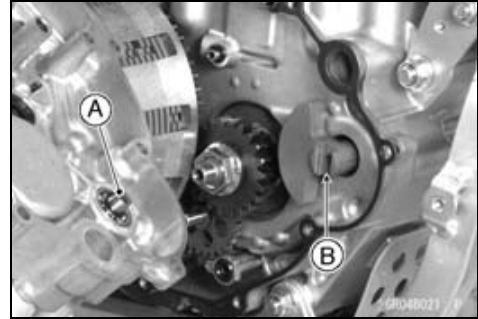

- Tighten:
 - Torque - Right Engine Cover Bolts: 9.8 N·m (1.0 kgf·m, 87 in·lb)**
- Insert the water hose [A] into the water pump cover [B], and tighten it with the clamp [C].
 - Torque - Water Hose Clamp Screw: 1.5 N·m (0.15 kgf·m,)**
- Install the kick pedal (see Kick Pedal Installation in the Periodic Maintenance chapter).
- Install the engine oil drain bolts surely (see Periodic Maintenance chapter).
- Pour in the specified type and amount of oil (see Engine Oil Change in the Periodic Maintenance chapter).
- Pour in the specified type and amount of coolant (see Coolant Filling in the Cooling System chapter).
- Check the rear brake for good braking power and no brake drag.

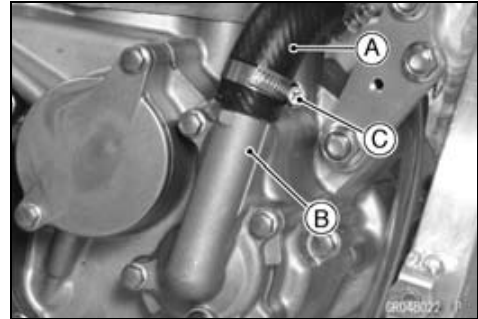

Release Shaft Removal

- Remove the clutch (see Clutch Removal).
- Remove the clutch cable upper end (see Clutch Cable Removal).
- Remove the tips [A] of the clutch cable (see Clutch Cable Removal).
- Pull the lever and shaft assembly [B] out of the crankcase.

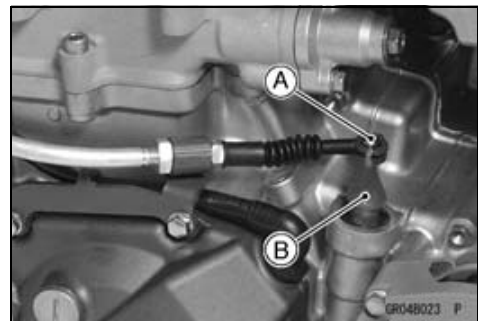

Release Shaft Installation

- Apply high-temperature grease to the oil seal lips.
- Apply engine oil to the bearing in the hole of the crankcase.
- Apply grease to the part where the push rod comes in contact.
- Insert the release shaft straight into the upper hole of the crankcase.

CAUTION

When inserting the release shaft, be careful not to remove the spring of the oil seal.

- Install the clutch cable (see Clutch Cable Installation).

6-12 ENGINE RIGHT SIDE

Clutch

Clutch Removal

- Drain the engine oil (see Engine Oil Change in the Periodic Maintenance chapter).
- Remove the clutch cover (see Clutch Cover Removal).
- Remove:
 - Clutch Spring Bolts [A]
 - Clutch Spring
 - Clutch Pressure Plate [B]

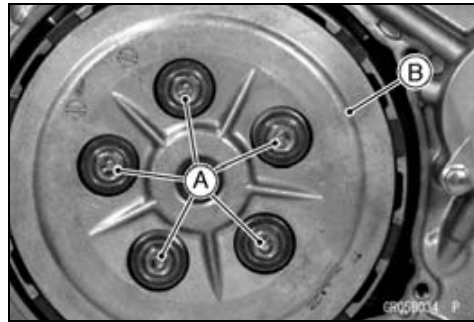

- Remove:
 - Washer [A]
 - Needle Bearing [B]
 - Push Rod Holder [C]
 - Push Rod
 - Friction Plates [D]
 - Steel Plates [E]

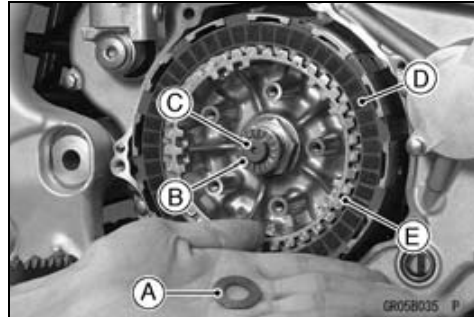

- Fix the clutch hub [A] with the clutch holder [B].
Special Tool - Clutch Holder: 57001-1243
- Loosen the clutch hub nut [C] counterclockwise.



- Remove:
 - Washer
 - Clutch Hub
 - Toothed Washer [A]
 - Clutch Housing [B]

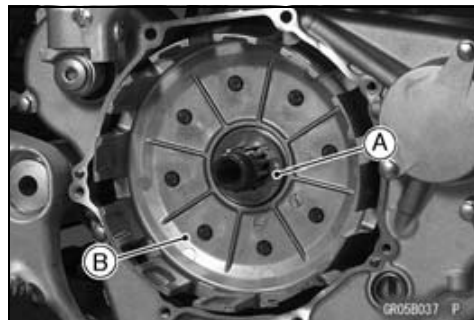

Clutch Installation

- Check the clutch plate assembly free play (see Clutch Plate Assembly Free Play Inspection/Adjustment).
- Apply molybdenum disulfide oil to the inside of the clutch housing gear.
- Install the clutch housing [A].
- Do not forget to install the toothed washer [B] before installing the clutch hub [C].

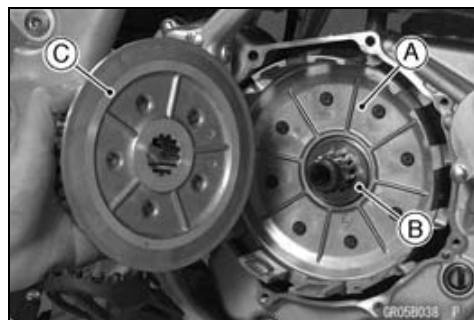

Clutch

- Install the washer so that stamp mark [A] facing the outside.



- Tighten the clutch hub nut [A] using the clutch holder [B].

Special Tool - Clutch Holder: 57001-1243

Torque - Clutch Hub Nut: 98 N·m (10 kgf·m, 72 ft·lb)

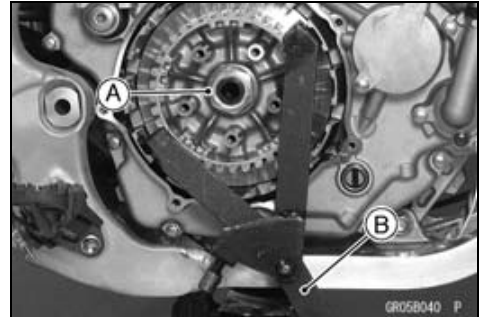

- Install the friction plates and steel plates, starting with a friction plate [A] and alternating them. Finishing with a friction plate.
- Install the friction plates which the lining blocks [B] on the plates installed to both end are more than the one of the other plates.
- Apply engine oil to the new friction plates when it shall be installed.

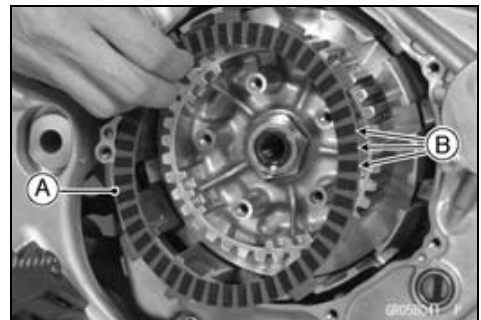

CAUTION

If dry steel plates and friction plates are installed, apply engine oil to the surfaces of each plate to avoid clutch plate seizure.

- Apply molybdenum disulfide grease to the rubbing portion [A] of the push rod holder.
- Install the push rod [B] and push rod holder.
- Apply molybdenum disulfide grease to the needle bearing [C] and washer [D], and install them.

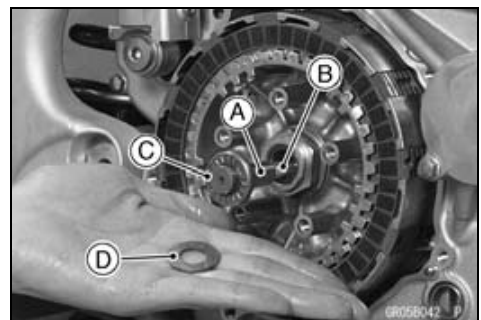

6-14 ENGINE RIGHT SIDE

Clutch

- Tighten:
Torque - Clutch Spring Bolts [A]: 8.8 N·m (0.90 kgf·m, 78 in·lb)
- Install the clutch cover (see Clutch Cover Installation).

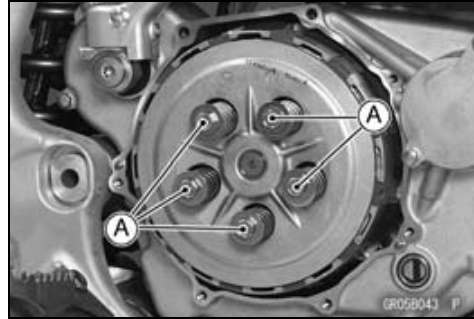

- Check the release shaft lever positions.
 ○Pushing [B] the release shaft lever [C] lightly frontward measure the distance [A] between the lever and cable bracket [D].

Release Shaft Lever Position

Standard: 68.6 ~ 76.4 mm (2.70 ~ 3.01 in.)

- ★If the lever position is not within the standard, select the correct thickness of adjusting washer(s) according to the tables shown.

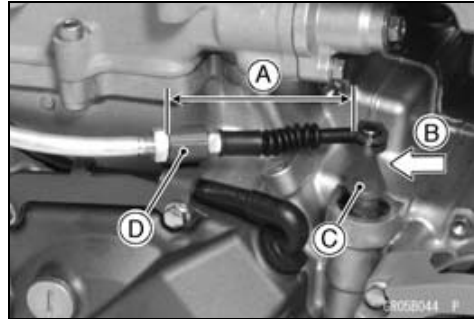

Adjusting Washers

Thickness	Part Number
1.5 mm	92200-1548
1.0 mm	92200-0045

Release Shaft Lever Position and Adjusting Washer Selection

Position Distance	Judgment	Washers Thickness	Qty
68.6 mm to 76.4 mm	Standard	1.5 mm	1
More than 76.4 mm	Too big	1.0 mm	1
Less than 68.6 mm	Too small	1.0 mm	2

- ★Remove the push rod holder assy as necessary and re-install the clutch.

Clutch

Clutch Plate Assembly Free Play Inspection/Adjustment

- Assemble the following parts.

- Clutch Hub [A]
- Friction Plates [B]
- Steel Plates [C]
- Friction Plates [D]
- Spring Plates [E]
- Spring [F]
- Bolts [G]

- The friction plates [B] have many lining blocks than other plates [D]. These plates are installed to both end of the all plates.

Torque - Clutch Spring Bolts: 8.8 N·m (0.90 kgf·m, 78 in·lb)

- Measure the clutch plate assembly [H].

Clutch Plate Length

Standard: 34.9 ~ 35.5 mm (1.37 ~ 1.40 in.)

- ★ If clutch plate length is not within the standard, select the correct length of steel plates according to the table shown.

Thickness	Part Number
1.2 mm (0.047 in.)	13089-1010
1.6 mm (0.063 in.) (STD)	13089-1095
2.0 mm (0.079 in.)	13089-1005

- Do not use the steel plate of 1.2 mm (0.047 in.) and 2.0 mm (0.079 in.) thickness at the same time.

Friction and Steel Plates Wear, Damage Inspection

- Refer to the Friction and Steel Plates Inspection in the Periodic Maintenance chapter.

Friction and Steel Plate Warp Inspection

- Refer to the Friction and Steel Plate Inspection in the Periodic Maintenance chapter.

Clutch Spring Free Length Inspection

- Measure the free length [A] of the clutch springs.
- ★ If any clutch spring is shorter than the service limit, it must be replaced.

Clutch Spring Free Length

Standard: 49.2 mm (1.94 in.)

Service Limit: 46.7 mm (1.84 in.)

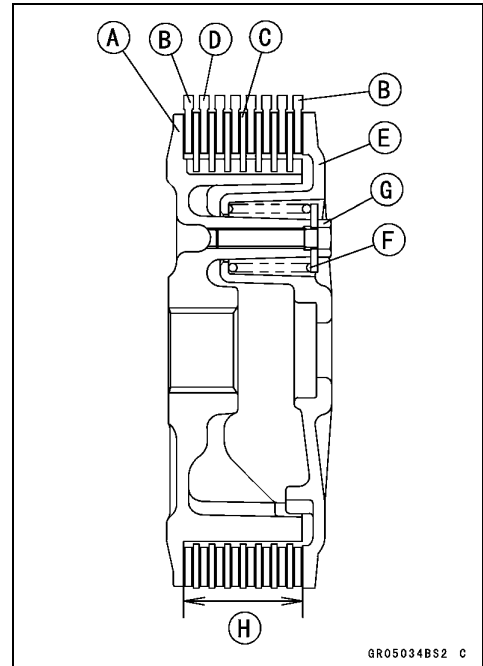

GR05034BS2 C

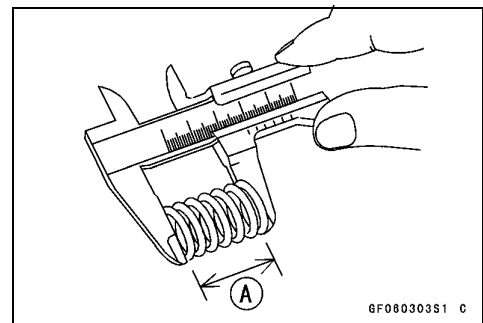

GF080303S1 C

6-16 ENGINE RIGHT SIDE

Clutch

Clutch Housing Finger Damage Inspection

- Visually inspect the clutch housing fingers [A] that come in contact with the friction plate tangs.
- ★ If they are damaged or if there are groove cuts in the areas that come in contact with the tangs, replace the housing. Replace the friction plates if their tangs are damaged as well.

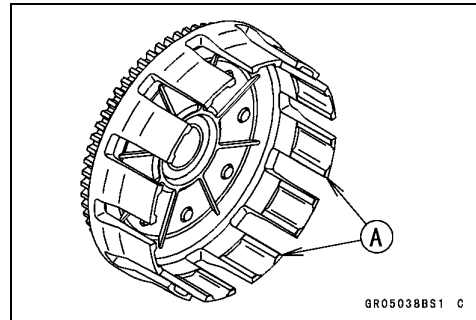

Friction Plate/Clutch Housing Clearance Inspection

- Measure the clearance between the tangs [A] on the friction plate and the fingers [B] of the clutch housing.
- ★ If this clearance is excessive, the clutch will be noisy.
- ★ If the clearance exceeds the service limit, replace the friction plates.

Friction Plate/Clutch Housing Clearance

Standard: 0.20 ~ 0.60 mm (0.0079 ~ 0.024 in.)

Service Limit: 0.8 mm (0.03 in.)

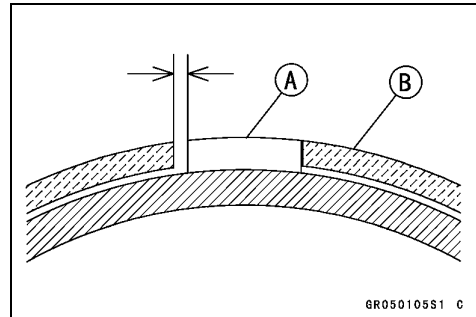

Clutch Hub Spline Damage Inspection

- Visually inspect the areas of the clutch hub splines that come in contact with the teeth of the steel plates.
- ★ If there are notches worn into the clutch hub splines [A], replace the clutch hub. Replace the steel plates if their teeth are damaged as well.

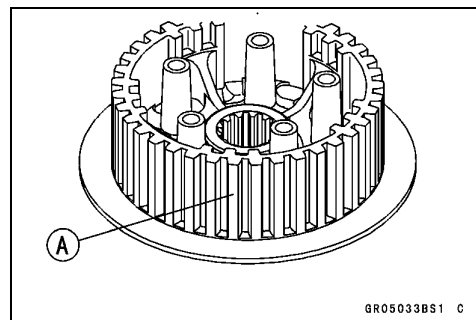

Primary Gear

Primary Gear Removal

- Remove:
 - Right Engine Cover
 - Clutch (see Clutch Removal)
- Temporarily install the clutch housing [A].
- Using the gear holder [B], secure the primary gear.
 - Special Tool - Gear Holder, m2.0: 57001-1557**
- Remove the clutch housing.
- Remove the primary gear nut [C], washer, primary gear [D] and oil pump drive gear.
- Primary gear nut is left-hand threads.

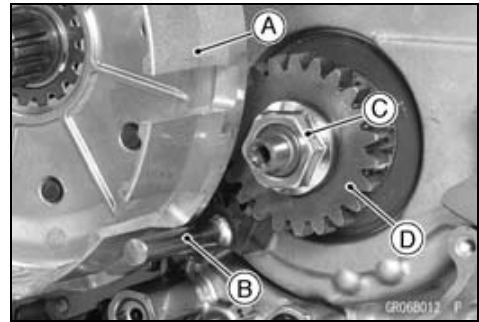

Primary Gear Installation

- Apply high-temperature grease to the oil seal lip.
- Insert the oil pump drive gear [A] and primary gear [B] to the crankshaft.
- Install the washer [C] as shown.

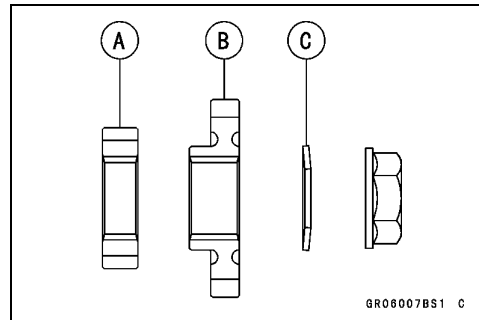

- Temporarily install the clutch housing.
- Using the gear holder [A], secure the clutch gear and the bottom of the primary gear; then, tighten the primary gear nut [B].
- Primary gear nut is left-hand threads.

Torque - Primary Gear Nut: 98 N·m (10 kgf·m, 72 ft·lb)

Special Tool - Gear Holder, m2.0: 57001-1557

- Install:
 - Clutch (see Clutch Installation)
 - Right Engine Cover (see Right Engine Cover Installation)

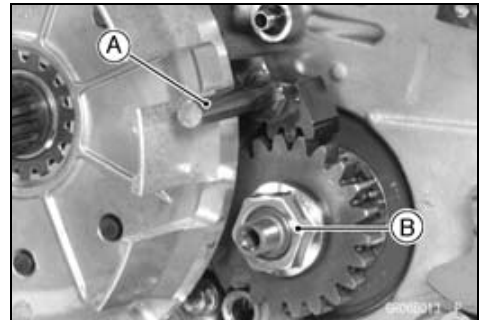

6-18 ENGINE RIGHT SIDE

External Shift Mechanism

External Shift Mechanism Removal

- Remove:
 - Shift Pedal Bolt [A]
 - Shift Pedal [B]

- Remove:
 - Right Engine Cover (see Right Engine Cover Removal)
 - Clutch Housing (see Clutch Removal)
 - Circlip [A]
 - Oil Pump Driven Gear [B]
- Pull out the shift shaft [C].
- Remove the bolt [D] and screw [E], take off the shift ratchet assembly [F] with ratchet plate [G].

- Remove the bolt [A] and shift dram cam [B].
- Remove the nut [C], and take off the gear set lever [D].

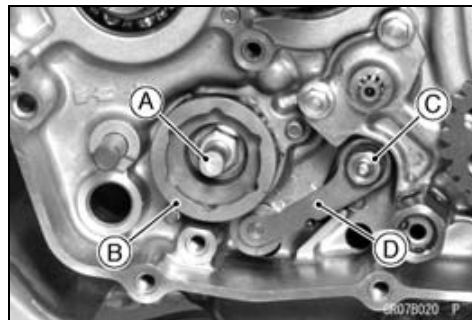
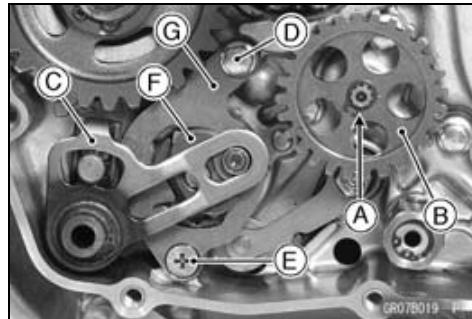
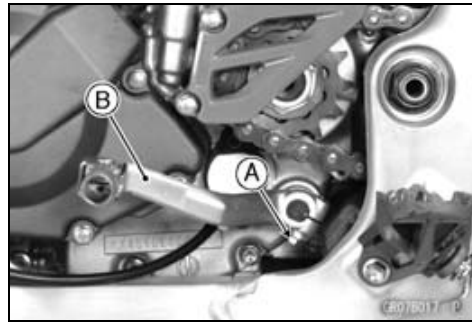

External Shift Mechanism Installation

- Install the gear set lever [A].
 - Fit each end of the spring [B] or original positions.
 - Do not forget to install the color and washer [C].
- Tighten the gear set lever nut [D].
 - Torque - Gear Set Lever Nut: 8.8 N·m (0.90 kgf·m, 78 in·lb)**

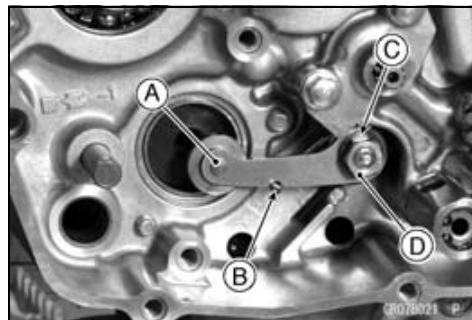

- Holding the gear set lever [A] with the (-) driver [B] and install the shift dram cam [C].
- Apply a non-permanent locking agent to the shift dram cam bolt.
- Fit the groove [D] on the pin [E].
- Align the roller of the gear set lever with the slot of the shift dram cam.

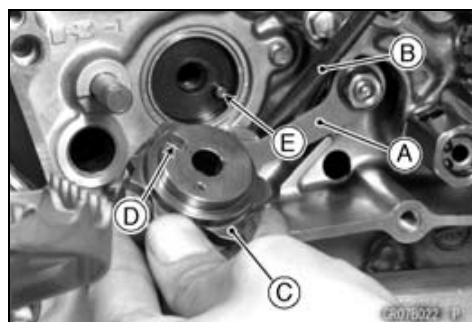

External Shift Mechanism

- Set up the shift ratchet assembly as shown in the figure.
 - Ratchet [A]
 - Pawls [B]
 - Pins [C]
 - Springs [D]
- Assembly the shift ratchet so that groove [E] of the pawl faces the crankcase side [F].

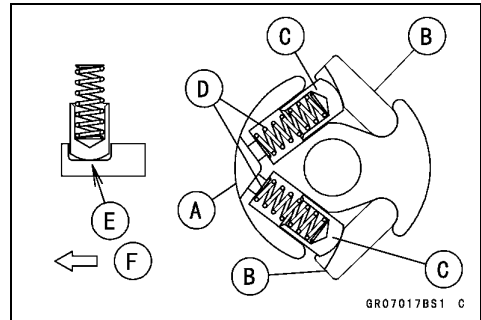

- Then install the ratchet assembly [A] to the ratchet plate [B] as shown in the figure.
- Install the ratchet assembly to the shift drum cam.
- Apply a non-permanent locking agent to the ratchet plate mounting screw.
- Tighten the screw first, and tighten the bolt.
- Tighten:

Torque - Ratchet Plate Mounting Screw: 6.4 N·m (0.65 kgf·m, 56 in·lb) (KX450D6F)
Ratchet Plate Mounting Bolt: 15 N·m (1.5 kgf·m, 11 ft·lb) (KX450D7F ~)
Ratchet Plate Mounting Bolt: 9.8 N·m (1.0 kgf·m, 87 in·lb)

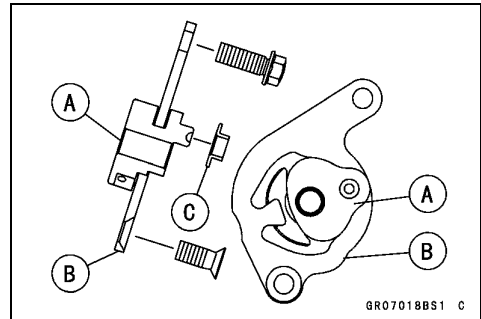

- Install the collar [C].
- Before installing the shift shaft, apply high temperature grease to the oil seal lips and shift shaft splines.
- Insert the shift shaft [A].
- Replace the circlip [B] with a new one.
- Install:
 - Oil Pump Driven Gear [C]
 - Circlip
 - Clutch (see Clutch Installation)
 - Right Engine Cover (see Right Engine Cover Installation)

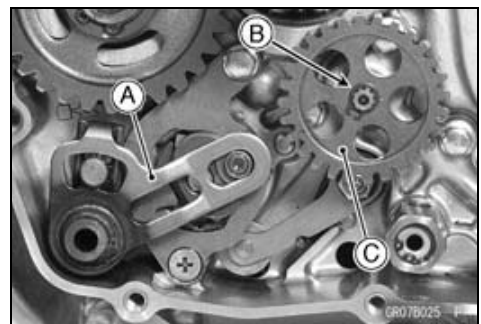

- Install the shift pedal so that the split portion [A] on the pedal align with the punch mark [B] on the shift shaft.
- Tighten:
 - Torque - Shift Pedal Bolt: 9.8 N·m (1.0 kgf·m, 87 in·lb)**

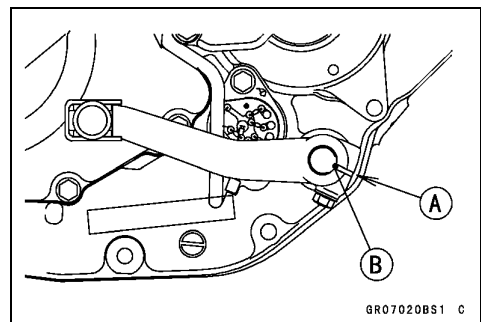

6-20 ENGINE RIGHT SIDE

External Shift Mechanism

External Shift Mechanism Inspection

- Check the shift shaft [A] for bending or damage to the splines.
 - ★ If the shaft is bent, straighten or replace it. If the splines are damaged, replace the shift mechanism.
 - Check the return spring [B] for cracks or distortion.
 - ★ If the spring is damaged in any way, replace it.
 - Check the shift lever [C] for distortion.
 - ★ If the shift lever is damaged in any way, replace the shift shaft.
-
- Check the ratchet assembly for damage.
 - ★ If ratchet [A], pawls [B], pins [C] or springs [D] are damaged in any way, replace them.
-
- Check the gear set lever [A] and its spring [B] for cracks or distortion.
 - ★ If the lever or spring is damaged in any way, replace them.
-
- Visually inspect the shift drum cam [A].
 - ★ If it is badly worn or if it shows any damage, replace it.

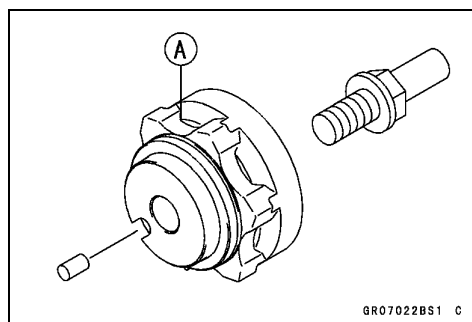
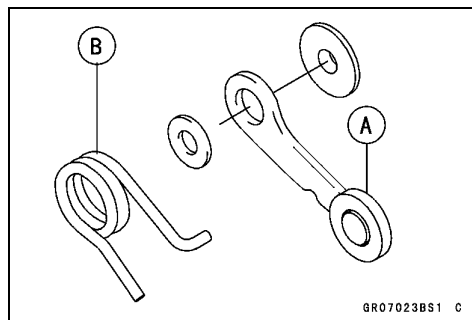
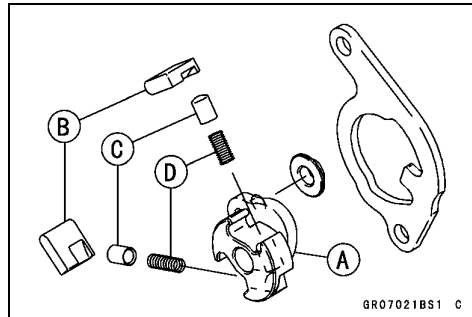
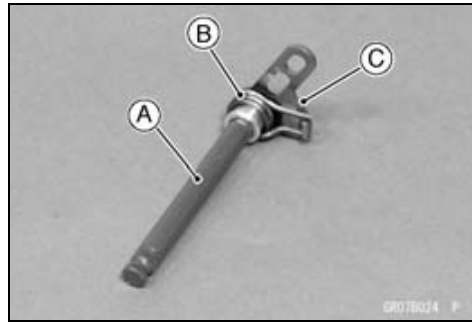

Kickstarter

Kick Pedal Assy Removal

- Remove:
 - Mounting Bolt [A]
 - Kick Pedal Assy [B]

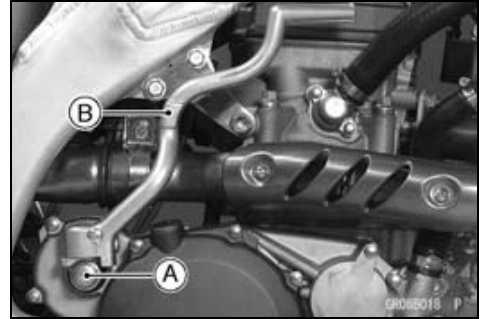

Kick Pedal Assy Installation

- Install the kick pedal assy [A] at the angle shown.
 - 17 ~ 27 mm (0.67 ~ 1.1 in.) [B]
- Apply a non-permanent locking agent to the kick pedal bolt.
- Tighten:
 - Torque - Kick Pedal Bolt: 25 N·m (2.5 kgf·m, 18 ft·lb)**

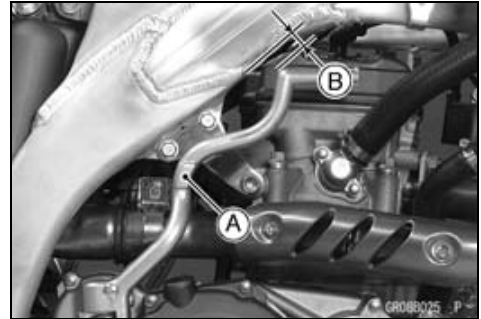

Kick Pedal Assy Disassembly

- Remove the kick pedal assy.
- Remove:
 - Plug Screw [A]
 - Spring [B]
 - Steel Ball [C]
 - Detent Screw [D]
 - Oil Seal [E]

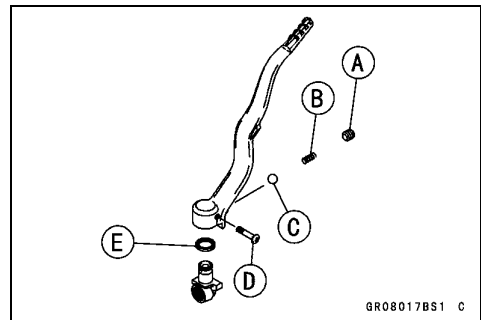

Kick Pedal Assy Assembly

- Apply high-temperature grease to the steel ball, oil seal lip, spring, and the sliding portion of the lever.
- After tightening the screws stake it with a punch.

Idle Gear Removal

- Remove:
 - Right Engine Cover (see Right Engine Cover Removal)
 - Clutch Housing (see Clutch Removal)
 - Circlip [A]
 - Idle Gear [B]

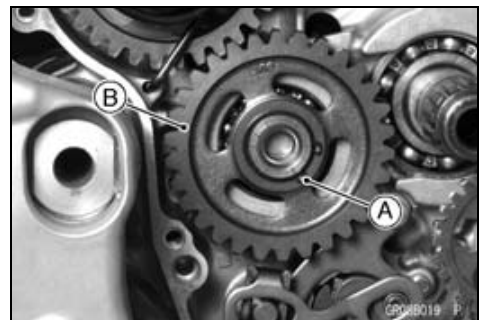

6-22 ENGINE RIGHT SIDE

Kickstarter

Idle Gear Installation

- Apply engine oil to the inside of the idle gear.
- Replace the circlip [A] with a new one.
- Install the idle gear [C] facing embossed letter [B] to the outside.
- Install the circlip.

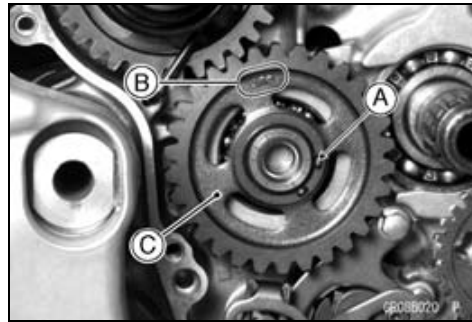

Kickshaft Removal

- Remove:
 - Right Engine Cover (see Right Engine Cover Removal)
 - Clutch Housing (see Clutch Removal)
- Pull the end [A] of the kick spring [B] out of the hole in the crankcase.
- Turn the kickshaft counterclockwise [C] and pull out the kickstarter assembly [D].

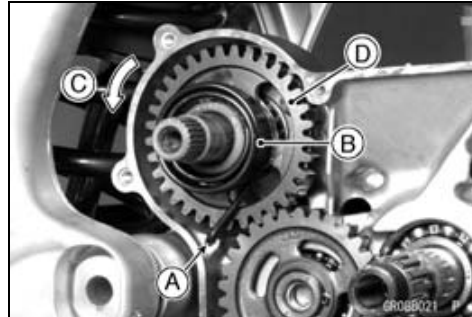

- Remove the bolt [A], and take off the ratchet guide [B].

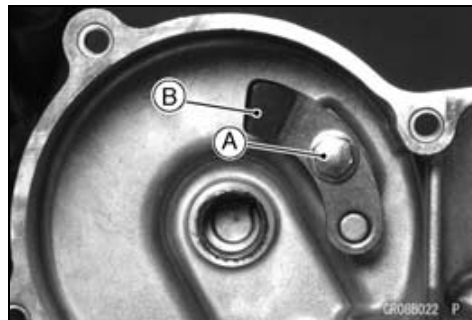

Kickshaft Installation

- Apply a non-permanent locking agent to the ratchet guide bolt.
- Install the ratchet guide [A].
 - Torque - Ratchet Guide Bolt: 8.8 N·m (0.90 kgf·m, 78 in·lb)**
- Apply molybdenum disulfide grease to the end of the kickshaft.
- Insert the kick shaft assembly [B] into the crankcase.
- Securely engage the stopper portion [C] of the ratchet gear with the guide.
- Insert the spring end [D] into the hole [E].
- Install:
 - Idle Gear (see Idle Gear Installation)
 - Clutch Housing (see Clutch Installation)
 - Right Engine Cover (see Right Engine Cover Installation)

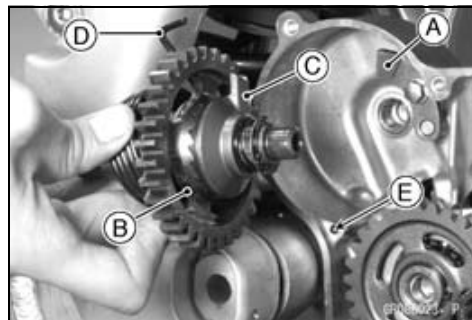

Kickstarter

Kick Shaft Assembly Disassembly/Assembly

- The kick shaft assembly consists of the following parts.

[A] Kick Gear	[E] Ratchet Gear
[B] Circlip	[F] Kick Shaft
[C] Washer	[G] Kick Spring
[D] Spring	[H] Spring Guide

- Check the kick shaft assembly parts for damage.
- ★ Any damaged parts should be replaced with new ones.

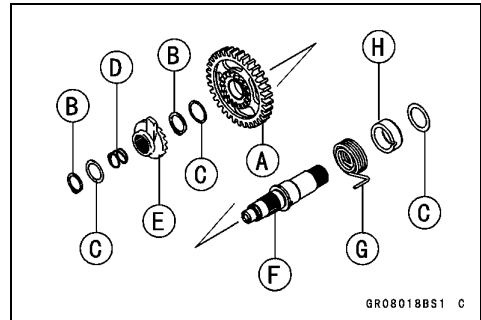

- Apply molybdenum disulfide grease to the inside of the kick gear and ratchet gear.
- Apply grease to the inside of the spring guide.
- When assembling the ratchet gear [A] onto the kick shaft [B], align the punch mark [C] on the ratchet gear with the punch mark [C] on the kick shaft.
- Replace the circlips that were removed with new ones.

Special Tool - Outside Circlip Pliers: 57001-144

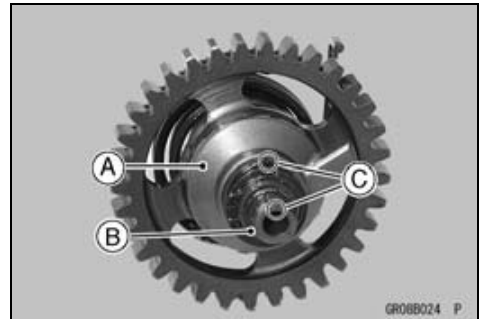

Engine Lubrication System

Table of Contents

Exploded View	7-2
Lubrication System Chart	7-4
Specifications	7-6
Special Tools	7-7
Engine Oil and Oil Filter.....	7-8
Engine Oil Level Inspection	7-8
Engine Oil Change	7-8
Oil Filter Change	7-9
Oil Screen (Scavenge) Removal.....	7-9
Oil Screen (Scavenge) Installation.....	7-9
Oil Screen (Feed) Removal	7-10
Oil Screen (Feed) Installation	7-10
Oil Screen (Scavenge) Cleaning.....	7-10
Oil Screen (Feed) Cleaning	7-11
Oil Pressure Relief Valve.....	7-12
Oil Pressure Relief Valve Removal	7-12
Oil Pressure Relief Valve Installation	7-12
Oil Pressure Relief Valve Inspection.....	7-12
Oil Pump.....	7-13
Oil Pump (Scavenge) Removal.....	7-13
Oil Pump (Scavenge) Installation.....	7-13
Oil Pump (Feed) Removal	7-14
Oil Pump (Feed) Installation	7-14
Oil Pump Inspection.....	7-15
Oil Pressure.....	7-16
Oil Pressure Measurement	7-16

7-2 ENGINE LUBRICATION SYSTEM

Exploded View

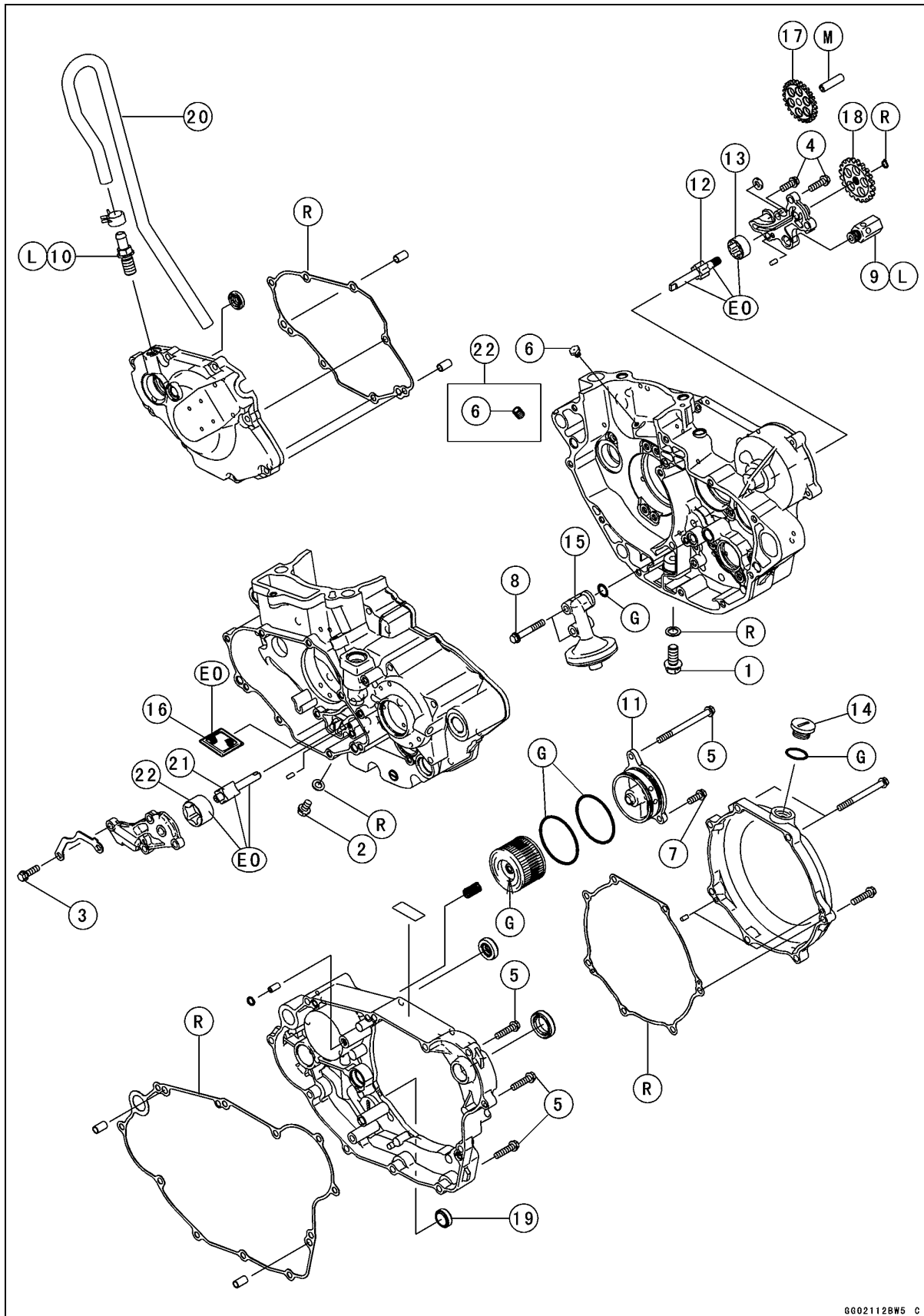

6G02112BWS C

ENGINE LUBRICATION SYSTEM 7-3

Exploded View

No.	Fastener	Torque			Remarks
		N·m	kgf·m	ft·lb	
1	Engine Oil Drain Bolt M10 (for transmission room oil sump)	20	2.0	15	
2	Engine Oil Drain Bolt M6 (for crank room oil sump)	7.0	0.71	62 in·lb	
3	Oil Pump (Scavenge) Cover Bolts	9.8	1.0	87 in·lb	S
4	Oil Pump (Feed) Cover Bolts	9.8	1.0	87 in·lb	S
5	Right Engine Cover Bolts	9.8	1.0	87 in·lb	
6	Piston Oil Nozzle (KX450D6F ~ D7F)	2.9	0.30	26 in·lb	
	Piston Oil Nozzle (KX450D8F)	4.0	0.41	35 in·lb	
7	Oil Filter Cover Bolt	9.8	1.0	87 in·lb	
8	Oil Screen (Feed) Mounting Bolts	9.8	1.0	87 in·lb	
9	Oil Pressure Relief Valve	15	1.5	11	L
10	Breather Fitting	15	1.5	11	L

- 11. Oil Filter Cover
- 12. Inner Rotor (feed)
- 13. Outer Rotor (feed)
- 14. Oil Filler Plug
- 15. Oil Screen (Feed)
- 16. Oil Screen (Scavenge)
- 17. Oil Pump Idle Gear
- 18. Oil Pump Gear
- 19. Oil Level Gauge
- 20. Breather Hose
- 21. Inner Rotor (Scavenge)
- 22. Outer Rotor (Scavenge)

EO: Apply engine oil.

G: Apply high-temperature grease.

L: Apply a non-permanent locking agent.

M: Apply molybdenum disulfide grease.

R: Replacement Parts

7-4 ENGINE LUBRICATION SYSTEM

Lubrication System Chart

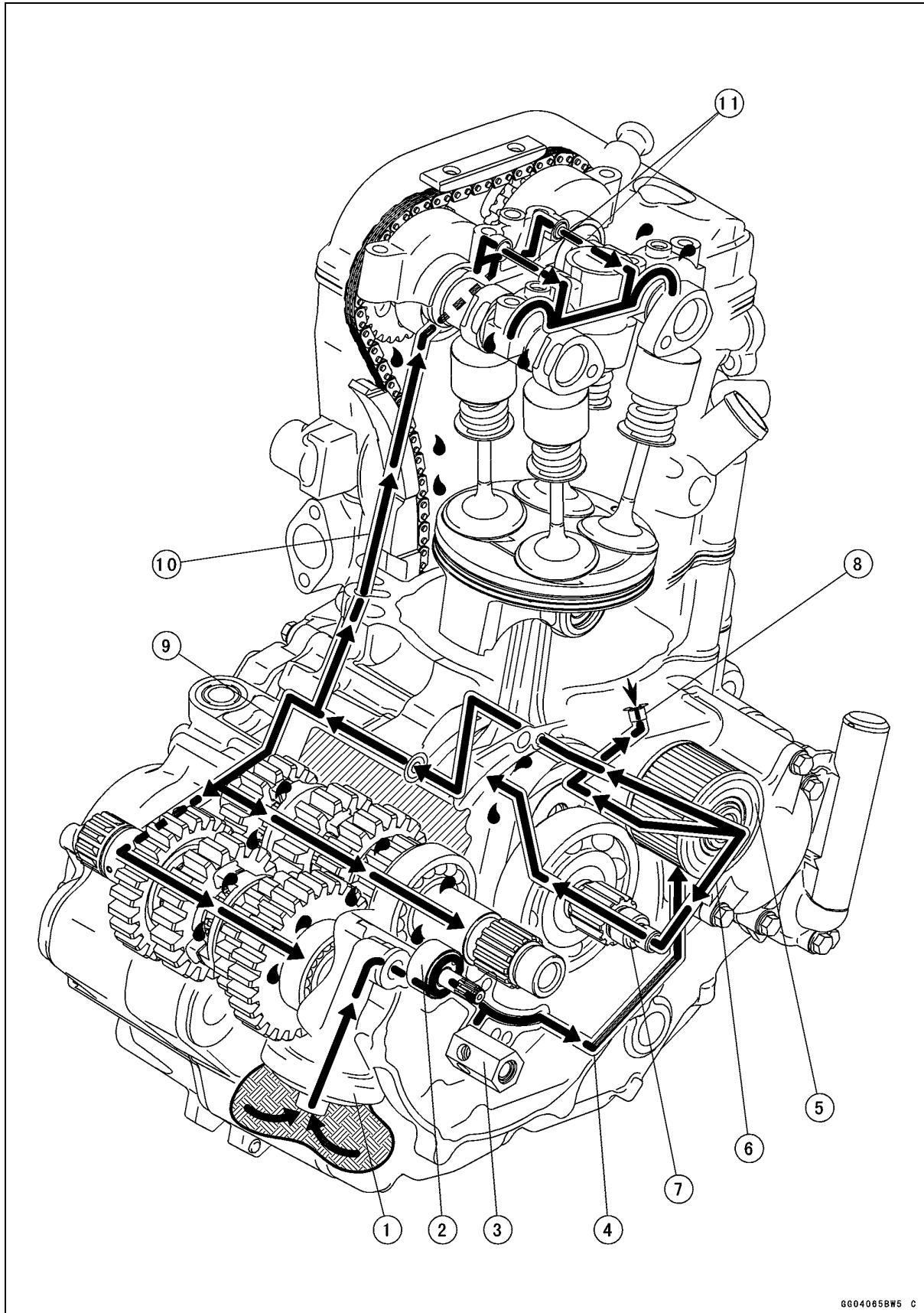

0004065BWS C

Lubrication System Chart

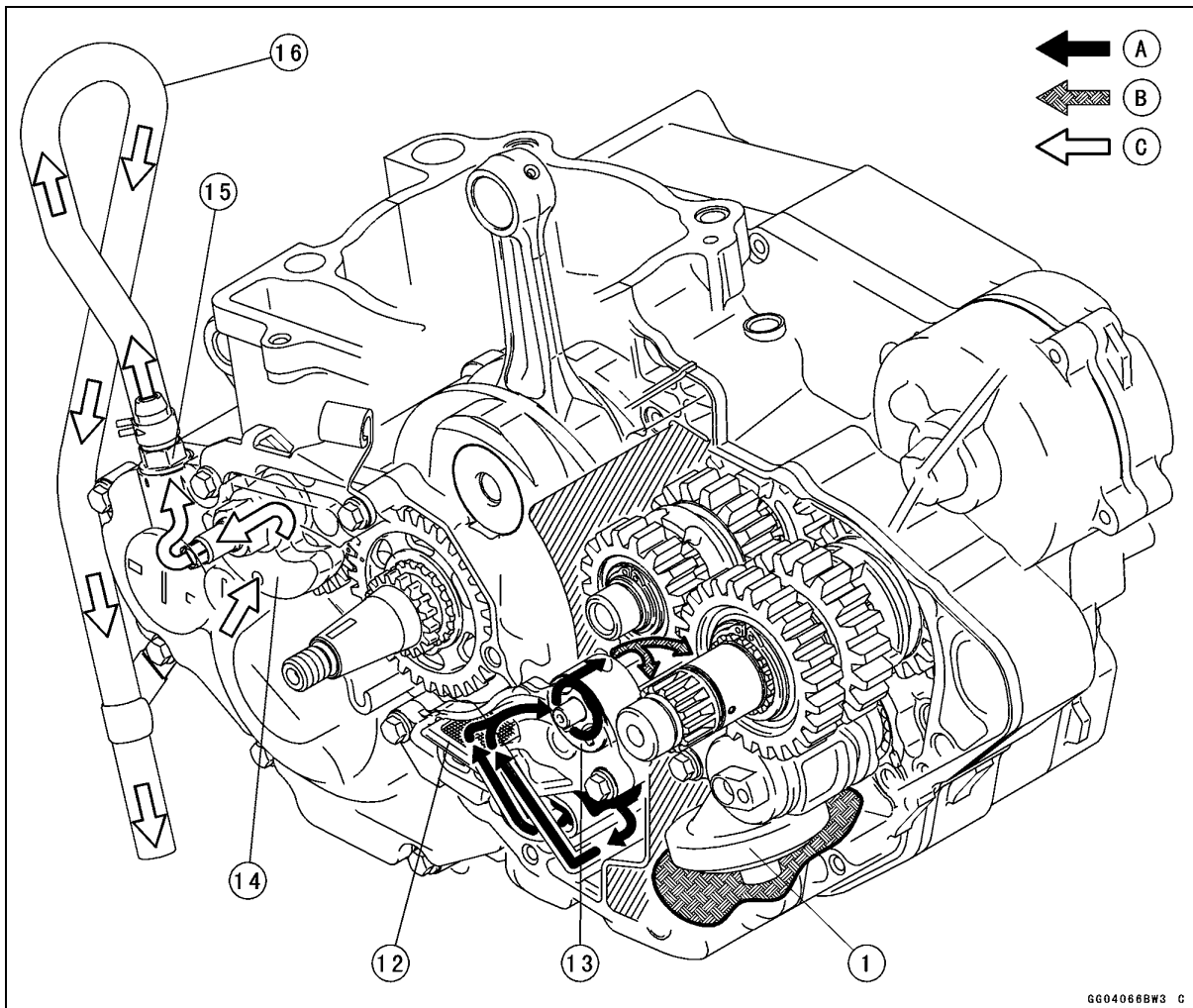

1. Oil Screen (feed)
 2. Oil Pump (feed)
 3. Oil Pressure Relief Valve
 4. Right Engine Cover Oil Passage (from Feed Oil Pump to Oil filter)
 5. Oil Filter
 6. Right Engine Cover Oil Passage (from Oil filter to Crankshaft)
 7. Crankshaft
 8. Piston Oil Nozzle
 9. Left Crankcase Oil Passage (from Oil filter to Transmission Oil Passage)
 10. Cylinder Oil Passage (from Crankcase Oil Passage to Cylinder Head Oil Passage)
 11. Oil Pipes
 12. Oil Screen (scavenge)
 13. Oil Pump (scavenge)
 14. Balancer Weight
 15. Fitting
 16. Breather Hose
- A: Crank Room Oil
 B: Transmission Room Oil
 C: Blowby Gas

7-6 ENGINE LUBRICATION SYSTEM

Specifications

Item	Standard
Engine Oil Grade Viscosity Capacity Oil Change - when filter is not removed Oil Change - when filter is removed when engine is completely dry Oil Level (after warm-up or driving)	Castrol "R4 Superbike" 5W-40 (KX450D6F ~ D7F), Castrol "POWER1 R4 Racing" 5W-40 (KX450D8F) or API SG, SH, SJ or SL with JASO MA SAE 10W-30, 10W-40, or 10W-50 0.96 L (1.01 US qt) 0.98 L (1.03 US qt) 1.2 L (1.3 US qt) Upper level
Oil Pressure Measurement (oil temperature 90°C, engine speed 4 000 rpm)	39 ~ 98 kPa (0.4 ~ 1.0 kgf/cm ² , 5.6 ~ 14 psi)

Special Tools

Oil Pressure Gauge, 5 kgf/cm²:
57001-125

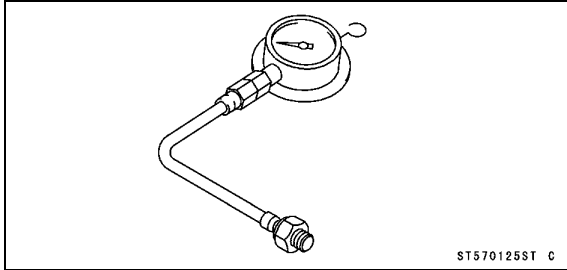

Oil Pressure Gauge Adapter, M10 × 1.25:
57001-1182

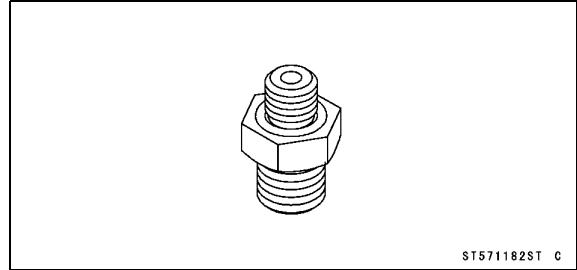

Outside Circlip Pliers:
57001-144

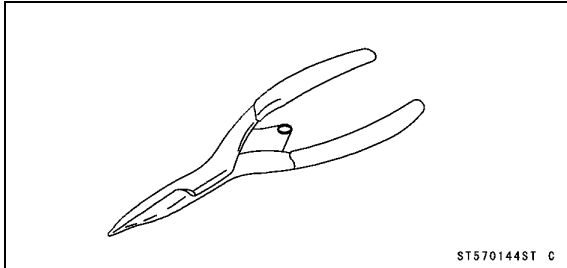

Oil Pressure Cap:
57001-1656

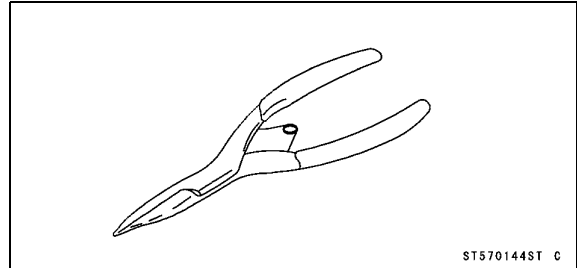

7-8 ENGINE LUBRICATION SYSTEM

Engine Oil and Oil Filter

⚠ WARNING

Motorcycle operation with insufficient, deteriorated, or contaminated engine oil will cause accelerated wear and may result in engine or transmission seizure, accident, and injury.

The engine oil level indicated in the right engine cover oil level gauge is very sensitive to the motorcycle's position and engine rpm at time of shut down. Because of the semi-dry sump lubrication system with separate oil chambers in the crank room and transmission room, under certain conditions oil can accumulate in the crank room and give a false low reading at the oil level gauge, which indicates oil volume in the transmission room.

Engine Oil Level Inspection

- Situate the motorcycle so that it is vertical.
- Check that the engine oil level is between the upper [A] and lower levels [B] in the gauge.

NOTE

- Situate the motorcycle so that it is perpendicular to the ground.
- If no oil appears in the gauge, tip the motorcycle slightly to the right until oil is visible then return to an upright position. If no oil appears even when tipped at an extreme angle, remove both drain bolts to empty any oil that may be in the transmission and crankcase, reinstall the drain bolts and refill with the specified amount of oil.
- If the motorcycle has just been used, wait several minutes for all the oil to drain down.
- If the oil has just been changed, start the engine and run it for several minutes **at idle speed**. This fills the oil filter with oil.
- **Do not run the engine at high engine speed.** Stop the engine, then wait several minutes until the oil settles.

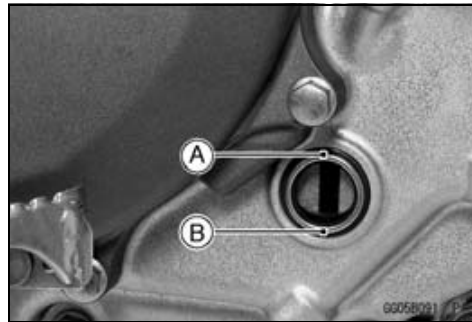

CAUTION

Racing the engine before the oil reaches every part can cause engine seizure.

- ★ If the oil level is too high, remove the excess oil through the filler opening, using a syringe or some other suitable device.
- ★ If the oil level is too low, add the correct amount of oil through the oil filler opening. Use the same type and make of oil that is already in the engine.

NOTE

- If the engine oil type and make are unknown, use any brand of the specified oil to top off the level rather than running the engine with the oil level low. Then at your earliest convenience, change the oil completely.

Engine Oil Change

- Refer to the Engine Oil Change in the Periodic Maintenance chapter.

Engine Oil and Oil Filter

Oil Filter Change

- Refer to the Oil Filter Change in the Periodic Maintenance chapter.

Oil Screen (Scavenge) Removal

- Remove the oil pump (scavenge) cover (see Oil Pump (Scavenge) Cover Removal).
- Pull out the oil screen [A] from the crankcase.

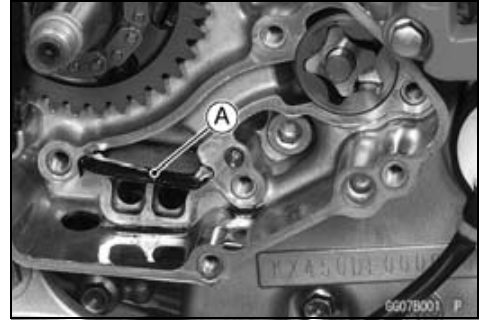

Oil Screen (Scavenge) Installation

- Clean the oil screens thoroughly whenever it is removed for any reason.
- Clean the oil screens with a high-flash point solvent and remove any particles stuck to them.

⚠ WARNING

Clean the screen in a well-ventilated area, and take care that there is no spark or flame anywhere near the working area. Because of the danger of highly flammable liquids, do not use gasoline or low-flash point solvents.

NOTE

○ While cleaning the screens, check for any metal particles that might indicate internal engine damage.

- Check the screens [A] carefully for any damage, holes, broken wires, gasket pulling off.
- ★ If the screen is damaged, replace it.

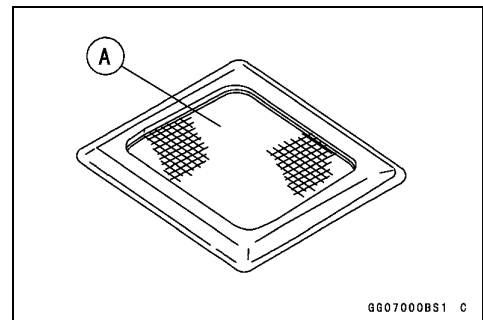

- Apply engine oil to the rubber portion [A] on the oil screen.
- Install the oil screen facing the carved line [B] to the outside.
- Install the oil pump (scavenge) cover.

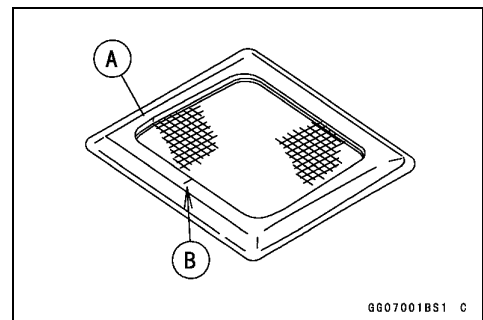

7-10 ENGINE LUBRICATION SYSTEM

Engine Oil and Oil Filter

Oil Screen (Feed) Removal

- Split the crankcase (see Crankcase Disassembly in the Crankshaft/Transmission chapter).
- Remove:
 - Bolts [A]
 - Oil Screen [B]

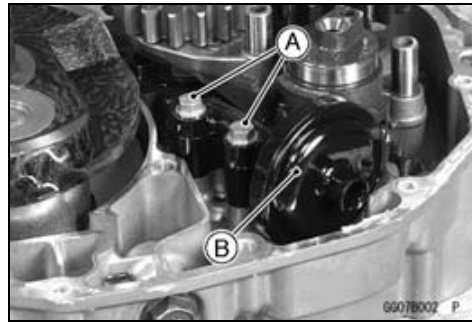

Oil Screen (Feed) Installation

- Replace the O-ring [A] with a new one.
- Apply grease to the O-ring, and install it.



- Install the oil screen [A], and tighten the bolts [B].
Torque - Oil Screen (Feed) Mounting Bolts: 9.8 N·m (1.0 kgf·m, 87 in·lb)

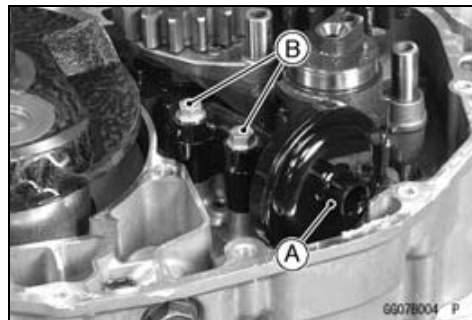

Oil Screen (Scavenge) Cleaning

- Remove the oil screen (see Oil Screen (Scavenge) Removal).
- Clean the oil screens with a high-flash point solvent and remove any particles stuck to them.

⚠ WARNING

Clean the screen in a well-ventilated area, and take care that there is no spark or flame anywhere near the working area. Because of the danger of highly flammable liquids, do not use gasoline or low-flash point solvent.

Engine Oil and Oil Filter

- Check the screen [A] carefully for any damage, holes, broken wires gasket pulling off.
- ★ If the screen is damaged, replace it.
- Install the oil screen (see Oil Screen (Scavenge) Installation).

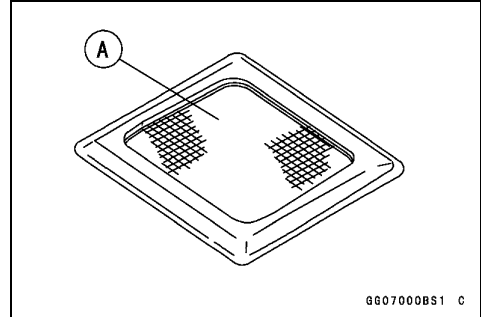

Oil Screen (Feed) Cleaning

- Remove the oil screen (see Oil Screen (Feed) Removal)
- Clean the oil screen with a high-flash point solvent and remove the particles stuck.
- Blow away the particles by applying compressed air [A] from the inside to the outside (from the clean side to the dirty side).

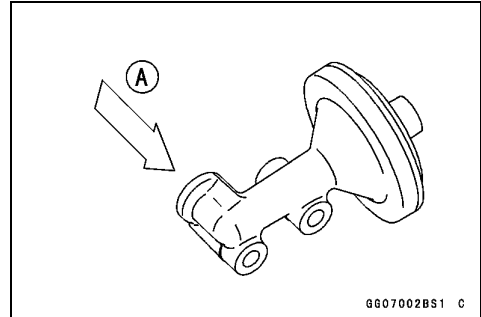

⚠ WARNING

Clean the screen in a well-ventilated area, and take care that there is no spark or flame anywhere near the working area. Because of the danger of highly flammable liquids, do not use gasoline or low-flash point solvents.

NOTE

- *While cleaning the screens, check for any metal particles that might indicate internal engine damage.*
- Check the screens carefully for any damage: holes and broken wires.
- ★ If the screen is damaged, replace the oil screen.

7-12 ENGINE LUBRICATION SYSTEM

Oil Pressure Relief Valve

Oil Pressure Relief Valve Removal

- Remove:
 - Clutch (see Clutch Removal in the Engine Right Side chapter)
 - Right Engine cover (see Right Engine Cover Removal in the Engine Right Side chapter)
- Remove the oil pressure relief valve [A].



Oil Pressure Relief Valve Installation

- Apply a non-permanent locking agent to the threads of oil pressure relief valve, and tighten it.
- Torque - Oil Pressure Relief Valve: 15 N·m (1.5 kgf·m, 11 ft·lb)**

Oil Pressure Relief Valve Inspection

- Remove the relief valve (see Oil Pressure Relief Valve Removal).
- Using a wooden stick, push the inner valve to make sure that the valve [A] moves smoothly and that it returns to its original position by the force of the spring [B].

NOTE

- The relief valve cannot be disassembled and it must be inspected in the assembled state.

- ★ If the valve movement is not smooth, wash the relief valve with high-flash point solvent, and use compressed air to remove any foreign particles from it.

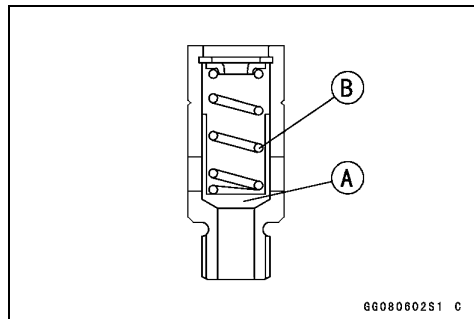

⚠ WARNING

Clean the oil pressure relief valve in a well-ventilated area, and take care that there is no spark or flame anywhere near the working area. Because of the danger of highly flammable liquids, do not use gasoline or low-flash point solvents.

- ★ If the valve does not move smoothly even after washing it, replace the relief valve. The oil pressure relief valve is precision made with no allowance for replacement of individual parts.

Oil Pump

Oil Pump (Scavenge) Removal

- Drain:
 - Engine Oil (see Engine Oil Change in the Periodic Maintenance chapter)
 - Coolant (see Coolant Draining in the Coolant System chapter)
- Remove:
 - Shift Pedal (see External Shift Mechanism in the Engine Right Side chapter)
 - Flywheel (see Flywheel Removal in the Electrical System chapter)
- Remove:
 - Oil Pump Cover Bolts [A]
 - Lower Camshaft Chain Guide [B]
 - Oil Pump Cover [C]

- Remove:
 - Inner Rotor [A]
 - Outer Rotor [B]

Oil Pump (Scavenge) Installation

- Install the dowel pin [A] to the crankcase.
- Apply engine oil to the each oil pump rotor and sliding surface of the oil pump shaft.
- Install:
 - Outer Rotor [B]
 - Inner Rotor [C]
- While turn the oil pump shaft, install the oil pump so that the left and right oil pump shaft may mesh in the crankcase.
- Install:
 - Oil Pump Cover [A]
 - Lower Camshaft Chain Guide [B]
- While pushing the oil pump cover, tighten the oil pump cover bolts following the sequence number as shown.
 - Torque - Oil Pump (Scavenge) Cover Bolts: 9.8 N·m (1.0 kgf·m, 87 in·lb)**

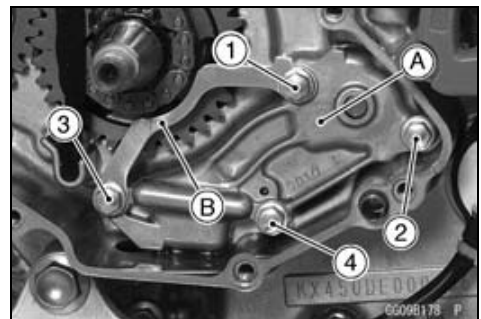
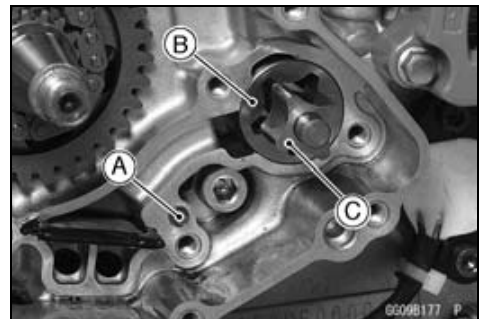
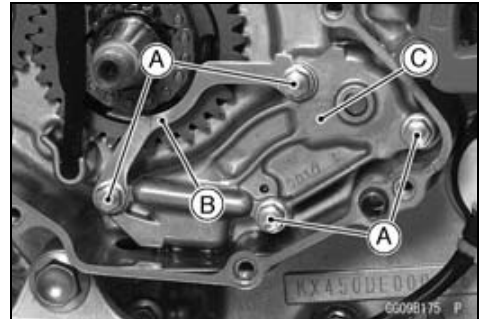

7-14 ENGINE LUBRICATION SYSTEM

Oil Pump

Oil Pump (Feed) Removal

- Remove:
 - Clutch (Clutch Removal in the Engine Right Side chapter)
 - Circlip [A]
 - Oil Pump Driven Gear [B]
 - Shaft [C]
 - Oil Pump Idle Gear [D]

Special Tool - Outside Circlip Pliers: 57001-144

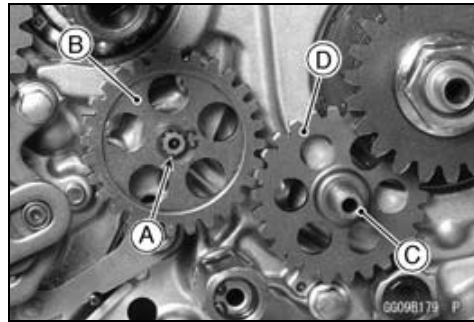

- Remove:
 - Oil Pump Cover Bolts [A]
 - Oil Pump Cover [B]
 - [C] KX450D6F ~ D7F
 - [D] KX450D8F

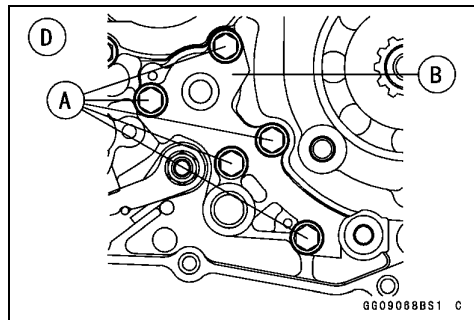
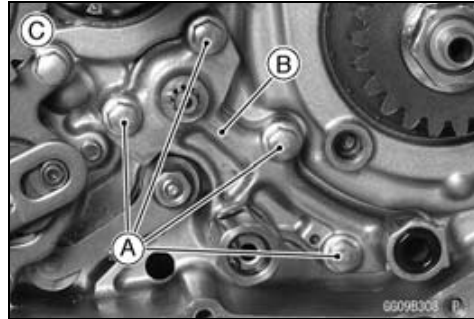

- Remove:
 - Inner Rotor [A]
 - Outer Rotor [B]

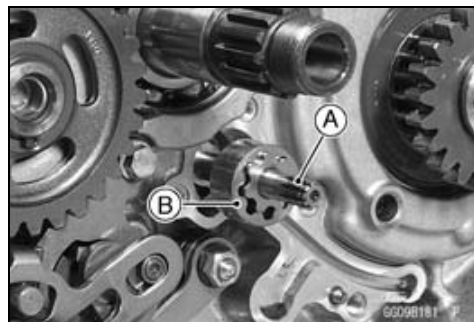

Oil Pump (Feed) Installation

- Install the dowel pins [A] to the crankcase.
- Apply engine oil to the each oil pump rotor and sliding surface of the oil pump shaft.
- Install:
 - Outer Rotor [B]
 - Inner Rotor [C]
- While turn the oil pump shaft, install the oil pump so that the left and right oil pump shaft may mesh in the crankcase.

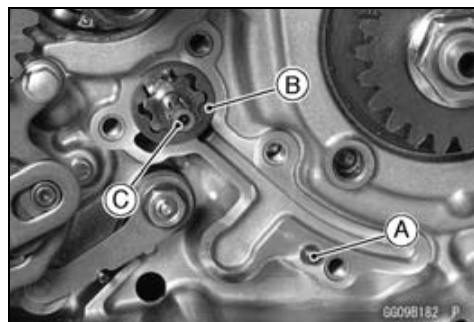

Oil Pump

- Install the oil pump cover [A].
- While pushing the oil pump cover, tighten the oil pump cover bolts following the sequence number as shown.
- Thread length of the bolt is 16 mm (0.63 in.) only in the bolt installed thirdly. (KX450D6F ~ D7F)
- Thread length of the bolts is 16 mm (0.63 in.) in the bolts installed thirdly and fifthly. (KX450D8F)
- [B] KX450D6F ~ D7F
- [C] KX450D8F

Torque - Oil Pump (Feed) Cover Bolts: 9.8 N·m (1.0 kgf·m, 87 in·lb)

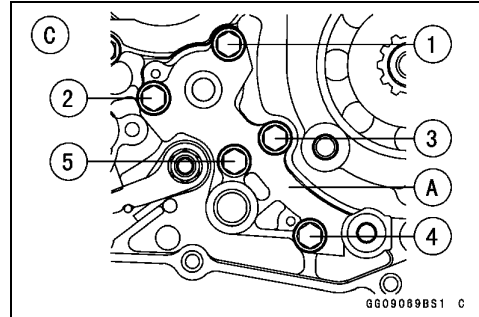
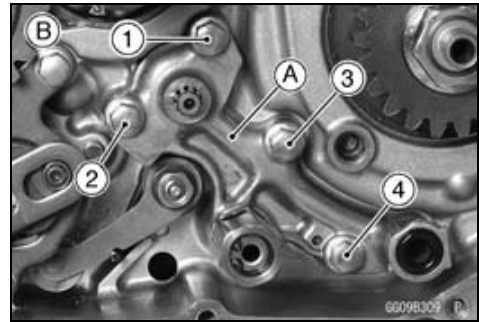

- Install the oil pump idle gear [A] facing the stepped side [B] to the outside.
- Replace the circlip [C] with a new one.
- Install the oil pump driven gear [D] and circlip.

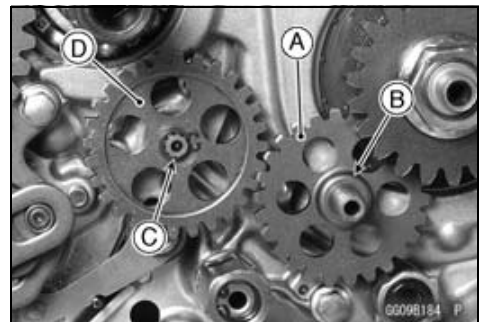

Oil Pump Inspection

- Remove the oil pump.
- Visually inspect the oil pump body, outer rotors and the inner rotors.
- ★ If the oil pump is any damaged or unevenly worn, replace the rotors, cover, or body, or the crankcase.

7-16 ENGINE LUBRICATION SYSTEM

Oil Pressure

Oil Pressure Measurement

- Remove the oil filter cover [A].
- Install the O-rings to the oil pressure cap.
Special Tool - Oil Pressure Cap: 57001-1656
- Install the oil pressure cap.

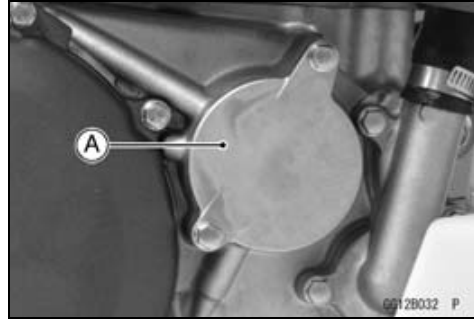

- Attach the oil pressure gauge adapter [A] and oil pressure gauge [B].

Special Tools - Oil Pressure Gauge Adapter, M10 × 1.0: 57001-1182

Oil Pressure Gauge, 5 kgf/cm²: 57001-125

- Start the engine and warm up the engine thoroughly.
- Run the engine at the specified speed, and read the oil pressure gauge.
- ★ If the oil pressure is much lower than the standard, check the feed oil pump.
- ★ If the reading is much higher than the standard, check the oil filter first, and oil passages for dirt or clogging.

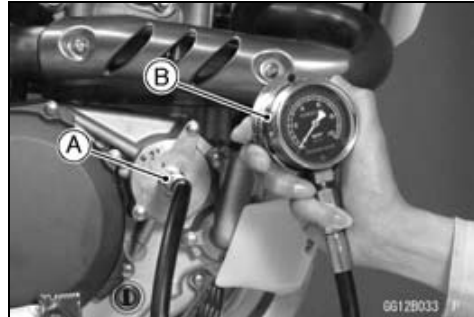

Oil Pump Pressure (oil temperature 90°C, @4 000 rpm)
Standard: 39 ~ 98 kPa (0.4 ~ 1.0 kgf/cm², 5.6 ~ 14 psi)

NOTE

- Warm up the engine thoroughly before measuring the oil pressure.
- Stop the engine and remove the oil pressure cap, oil pressure gauge adapter and gauge.

⚠ WARNING

Take care against burns from hot engine oil that will drain through the oil passage when the oil pressure gauge adapter is removed.

- Install the oil filter cover.
Torque - Oil Filter Cover Bolts: 9.8 N·m (1.0 kgf·m, 87 in·lb)

Engine Removal/Installation

Table of Contents

Exploded View	8-2
Special Tool	8-4
Engine Removal/Installation	8-5
Engine Removal.....	8-5
Engine Installation.....	8-7

8-2 ENGINE REMOVAL/INSTALLATION

Exploded View

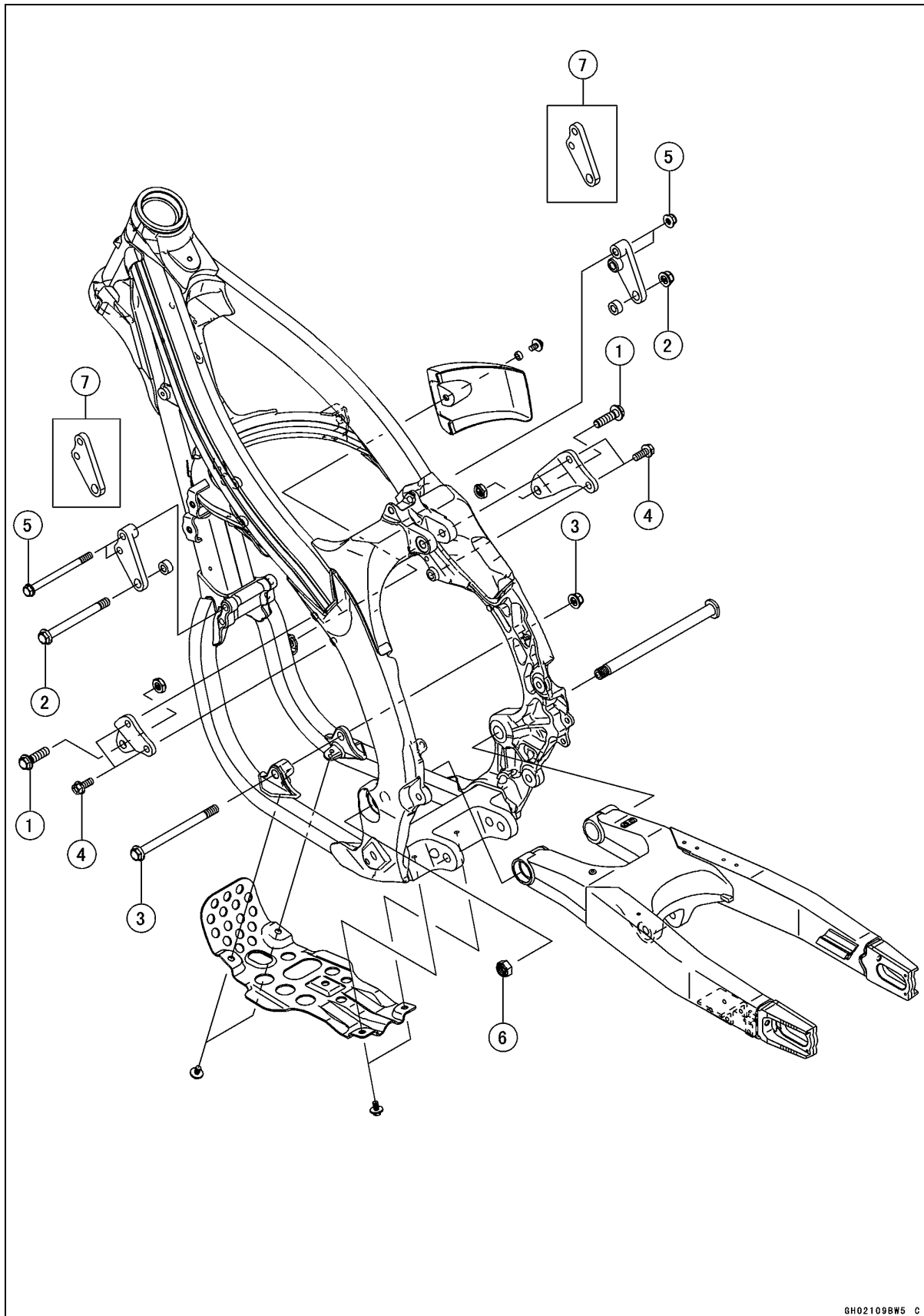

GH02109BWS C

ENGINE REMOVAL/INSTALLATION 8-3

Exploded View

No.	Fastener	Torque			Remarks
		N·m	kgf·m	ft·lb	
1	Upper Engine Mounting Bolts (M10)	49	5.0	36	
2	Middle Engine Mounting Bolt, Nut (M10)	49	5.0	36	
3	Lower Engine Mounting Bolt, Nut (M10)	49	5.0	36	
4	Upper Engine Bracket Bolts (M8)	29	3.0	21	
5	Middle Engine Bracket Bolts, Nuts (M8)	29	3.0	21	
6	Swingarm Pivot Shaft Nut	98	10	72	

7. KX450D6F ~ D7F

8-4 ENGINE REMOVAL/INSTALLATION

Special Tool

Jack:
57001-1238

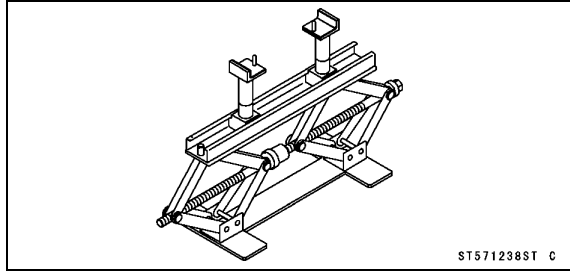

Engine Removal/Installation

Engine Removal

- Place the jack [A] under the frame to support the motorcycle.

Special Tool - Jack: 57001-1238

⚠ WARNING

For engine removal, the swingarm pivot shaft must be pulled out, causing the swingarm and rear wheel assembly to become detached. To prevent the motorcycle from falling, make sure to support the frame with a jack.

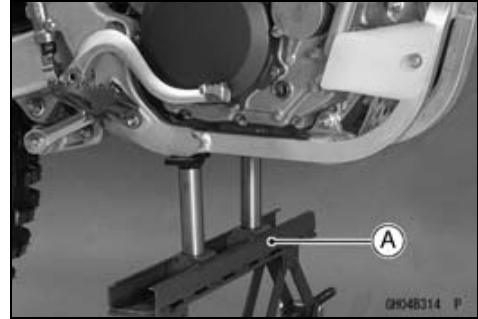

- Squeeze the brake lever slowly and hold it with a band [A].

⚠ WARNING

Be sure to hold the front brake when removing the engine, or the motorcycle may fall over. It could cause an accident and injury.

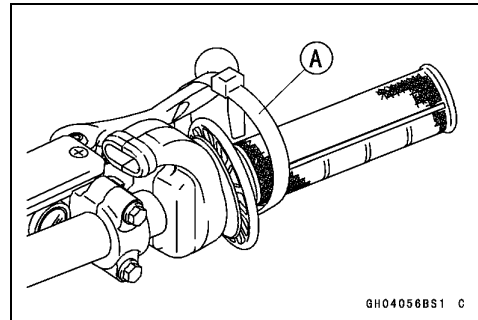

CAUTION

Be sure to hold the front brake when removing the engine, or the motorcycle may fall over. The engine or the motorcycle could be damaged.

- Drain:
 - Engine Oil (see Engine Oil Change in the Periodic Maintenance chapter)
 - Coolant (see Coolant Draining in the Cooling system chapter)
- Remove the mounting bolt [A] and remove the engine guard [B].

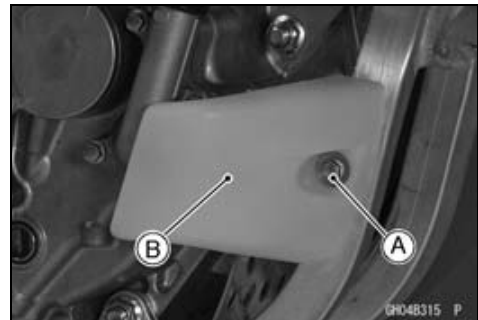

- Remove:
 - Seat (see Seat Removal in the Frame chapter)
 - Side Covers (see Side Cover Removal in the Frame chapter)
 - Fuel Tank (see Fuel Tank Removal in the Fuel System chapter)

- Remove:
 - Water Hoses [A]
 - Bolt [B]
 - Radiator Screen [C]

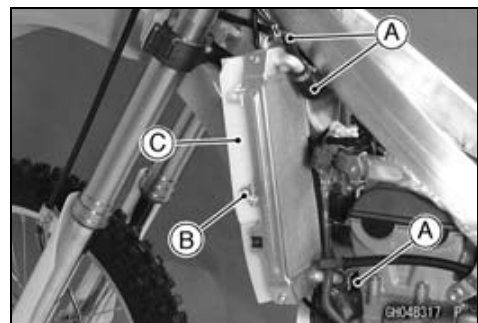

8-6 ENGINE REMOVAL/INSTALLATION

Engine Removal/Installation

- Remove:
Radiator Mounting Bolts [A]
Radiator [B]

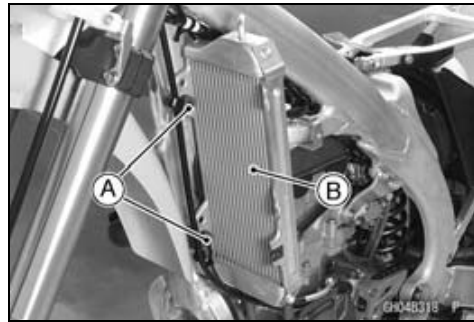

- Remove:
Muffler (see Muffler Removal in the Engine Top End chapter)
Water Hoses [B]
Bolt [C]
Radiator Screen [D]

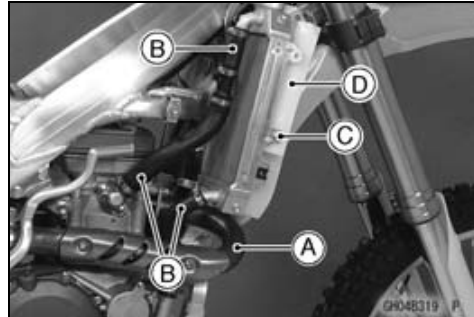

- Remove:
Radiator Mounting Bolts [A]
Radiator [B]

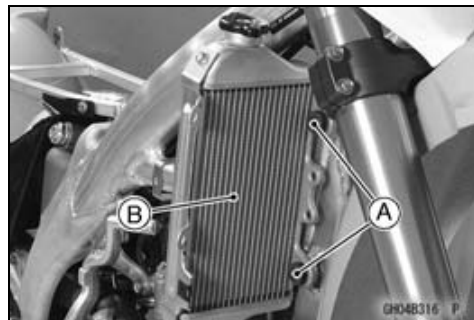

- Loosen:
Carburetor Clamp Bolts [A]
- Remove:
Air Cleaner Duct [B] with Rear Frame (see Rear Frame Removal in the Frame chapter)
Carburetor [C] (see Carburetor Removal in the Fuel System chapter)
Clutch Cable Lower End [D] (see Engine Right Side chapter)
Drive Chain [E] (cut out)

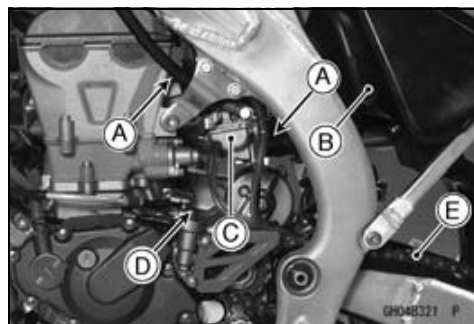

- Remove:
Bolts [A]
Rear Brake Pedal [B]
Master Cylinder [C]

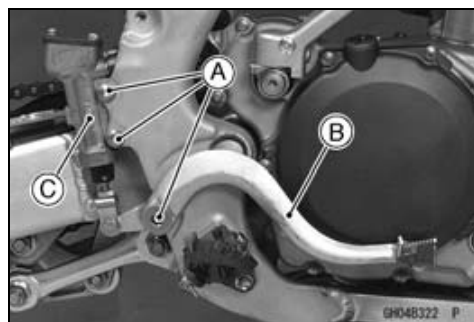

Engine Removal/Installation

- Pry open the clamps [A].
- Disconnect:
 - Magnet Lead Connector [B]
 - Gear Position Switch Connector [C]
 - Ignition Coil Lead Connector [D]
 - Spark Plug Cap

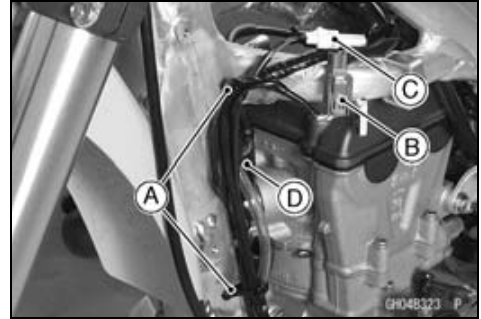

- Remove:
 - Ignition Coil [A]
 - Upper Engine Bracket Bolts (Left and Right) [B]
 - Upper Engine Mounting Bolt and Nut (Left and Right) [C]
 - Upper Engine Brackets (Left and Right) [D]
 - Engine Guard [E]
 - Middle Engine Bracket Bolts and Nuts [F]
 - Middle Engine Mounting Bolt and Nut [G]
 - Middle Engine Brackets (Left and Right) [H]
 - Collars (Left and Right) (KX450D8F)
 - Lower Engine Mounting Bolts and Nuts [I]

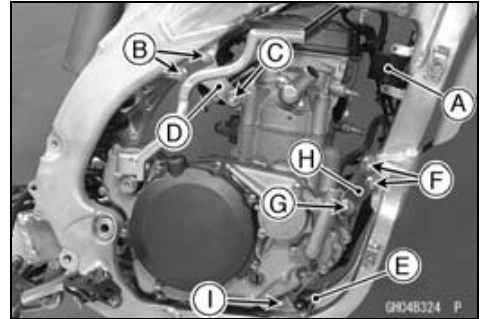

- Remove the swingarm pivot shaft nut [A] to pull out the swingarm pivot shaft [B].
- Pull out the swingarm pivot shaft half way from right side to free the engine.
- Remove the engine from the vehicle to right side.
- Clear the engine rear portion from the swingarm and then remove the engine.

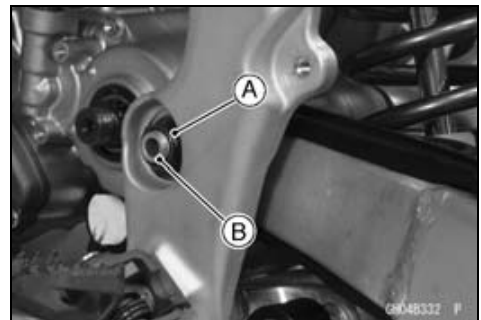

Engine Installation

- Install the engine.
 - First, insert the front portion of the engine, and then install the rear portion.
 - Install the swingarm pivot shaft, all engine bracket and mounting bolts temporarily.
 - Install the collars at the left and right brackets. (KX450D8F)
 - Swingarm pivot shaft insert from the right side.
 - Insert the middle and lower engine mounting bolts from the left side.
 - Tighten the pivot shaft, engine mounting bolts and engine bracket bolts.

Torque - Swingarm Pivot Shaft Nut: 98 N·m (10 kgf·m, 72 ft·lb)

Engine Mounting Bolts: 49 N·m (5.0 kgf·m, 36 ft·lb)

Engine Bracket Bolt: 29 N·m (3.0 kgf·m, 21 ft·lb)

8-8 ENGINE REMOVAL/INSTALLATION

Engine Removal/Installation

- Install the removed parts (see Appropriate chapter).
- Run the cables, hoses, and leads according to the Cable, Wire and Hose Routing section in the Appendix chapter.
- Fill:
 - Engine Oil (see Engine Oil Change in the Periodic Maintenance chapter)
 - Coolant (see Coolant Draining in the Cooling System chapter)
- Adjust:
 - Throttle Cable (see Throttle Grip (Throttle Cable) Free Play Adjustment in the Periodic Maintenance chapter)
 - Clutch Cable (see Clutch Lever (Clutch Cable) Free Play Adjustment in the Periodic Maintenance chapter)
 - Drive Chain (see Drive Chain Slack Adjustment in the Periodic Maintenance chapter)
- Adjust the idling (see Idle Speed Adjustment in the Periodic Maintenance chapter).
- Check the operation of the clutch lever.
- Check the brake effectiveness.

WARNING

Do no attempt to drive the motorcycle until you pump the brake pedal until the pads are against the disc. The brake will not function on the first application of the pedal if this is not done.

Crankshaft/Transmission

Table of Contents

Exploded View	9-2
Specifications	9-4
Special Tools and Sealant	9-5
Crankcase	9-6
Crankcase Disassembly	9-6
Crankcase Assembly	9-8
Crankshaft	9-14
Crankshaft Removal	9-14
Crankshaft Installation	9-14
Crankshaft Disassembly	9-14
Crankshaft Assembly	9-14
Crankshaft Inspection	9-15
Connecting Rod Bend Inspection	9-16
Connecting Rod Twist Inspection.....	9-17
Transmission	9-18
Transmission Shaft Removal	9-18
Transmission Shaft Installation	9-18
Transmission Shaft Disassembly.....	9-18
Transmission Shaft Assembly.....	9-19
Shift Fork Bending Inspection	9-22
Shift Fork/Gear Groove Wear Inspection.....	9-22
Shift Fork Guide Pin/Shift Drum Groove Wear Inspection	9-22
Gear Damage Inspection	9-22
Balancer	9-23
Balancer Removal.....	9-23
Balancer Installation.....	9-23
Bearings/Oil Seals	9-24
Bearing Replacement	9-24
Bearing Inspection	9-24
Oil Seal Inspection	9-25

9-2 CRANKSHAFT/TRANSMISSION

Exploded View

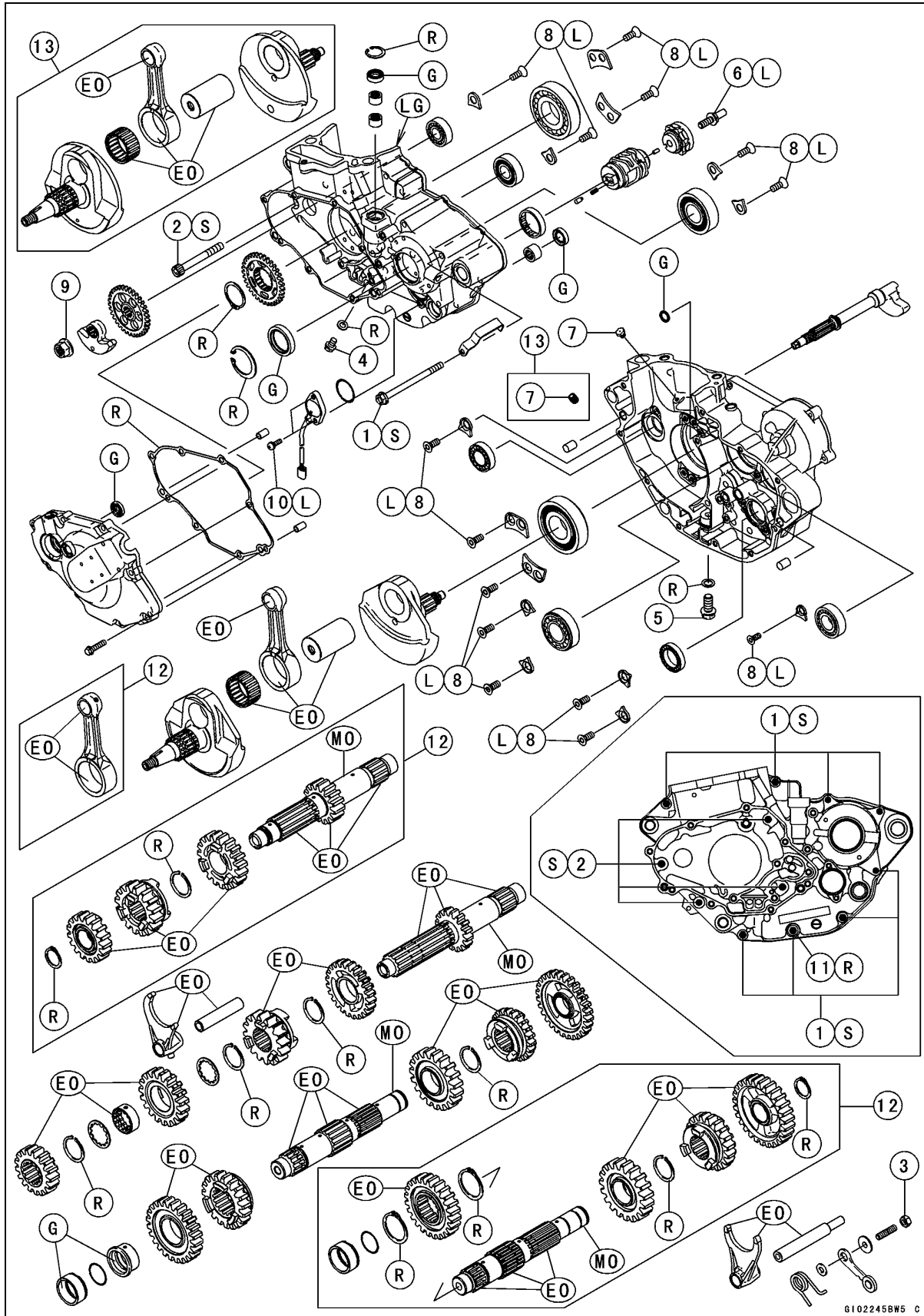

CRANKSHAFT/TRANSMISSION 9-3

Exploded View

No.	Fastener	Torque			Re- marks
		N·m	kgf·m	ft·lb	
1	Crankcase Bolts (M6)	12	1.2	104 in·lb	S
2	Crankcase Bolts (M7)	15	1.5	11	S
3	Gear Set Lever Nut	8.8	0.90	78 in·lb	
4	Engine Oil Drain Bolt (M10)(For Transmission Room Oil Sump)	20	2.0	15	
5	Engine Oil Drain Bolt (M6)(For Crank Room Oil Sump)	7.0	0.71	62 in·lb	
6	Shift Drum Cam Bolt	24	2.4	17	L
7	Piston Oil Nozzle (KX450D6F ~ D7F)	2.9	0.30	26 in·lb	
	Piston Oil Nozzle (KX450D8F)	4.0	0.41	35 in·lb	
8	Bearing Retaining Screws	15	1.5	11	L
9	Balancer Weight Mounting Nut	52	5.3	38	
10	Gear Position Switch Screws	2.9	0.30	26 in·lb	L

11. Copper Washer

12. KX450D6F

13. KX450D6F ~ D7F

EO: Apply engine oil.

G: Apply grease.

L: Apply a non-permanent locking agent.

MO: Apply molybdenum disulfide oil.

LG: Apply liquid gasket.

R: Replacement parts

S: Tighten the fasteners following the specified sequence.

9-4 CRANKSHAFT/TRANSMISSION

Specifications

Item	Standard	Service Limit
Connecting Rods		
Connecting Rod Big End Radial Clearance	0.002 ~ 0.014 mm (0.00008 ~ 0.0006 in.)	0.06 mm (0.002 in.)
Connecting Rod Big End Side Clearance	0.25 ~ 0.35 mm (0.0098 ~ 0.014 in.)	0.6 mm (0.02 in.)
Crankshaft Runout	TIR 0.03 mm (0.0012 in.) or less	TIR 0.08 mm (0.0031 in.)
Connecting Rod Bend	---	TIR 0.2 mm (0.08 in.)/100 mm (3.94 in.)
Connecting Rod Twist	---	TIR 0.2 mm (0.08 in.)/100 mm (3.94 in.)
Transmission		
Shift Fork Ear Thickness	4.9 ~ 5.0 mm (0.193 ~ 0.197 in.)	4.8 mm (0.19 in.)
Gear Shift Fork Groove Width	5.05 ~ 5.15 mm (0.199 ~ 0.203 in.)	5.25 mm (0.207 in.)
Shift Fork Guide Pin Diameter	5.9 ~ 6.0 mm (0.232 ~ 0.236 in.)	5.8 mm (0.228 in.)
Shift Drum Groove Width	6.05 ~ 6.20 mm (0.238 ~ 0.244 in.)	6.3 mm (0.25 in.)

TIR: Total Indicator Readings

Special Tools and Sealant

Outside Circlip Pliers:
57001-144

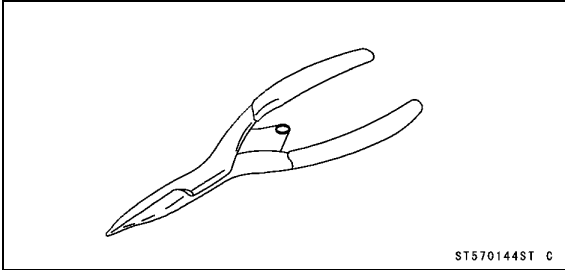

Crankcase Splitting Tool Assembly:
57001-1362

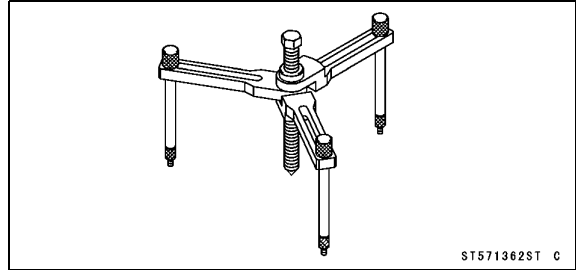

Bearing Driver Set:
57001-1129

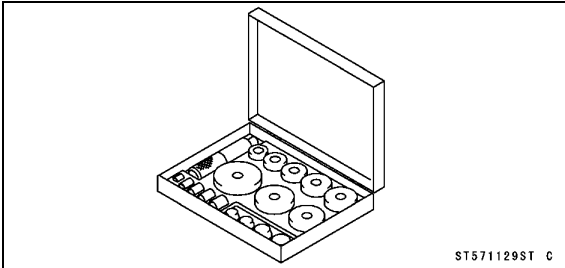

Kawasaki Bond (Liquid Gasket - Gray):
92104-1063

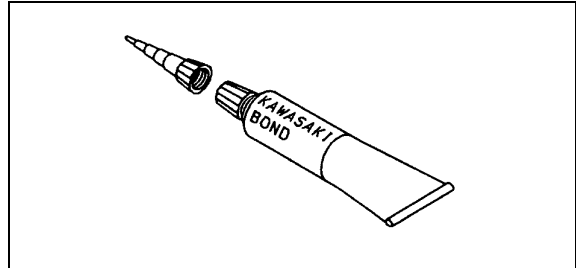

Crankshaft Jig:
57001-1174

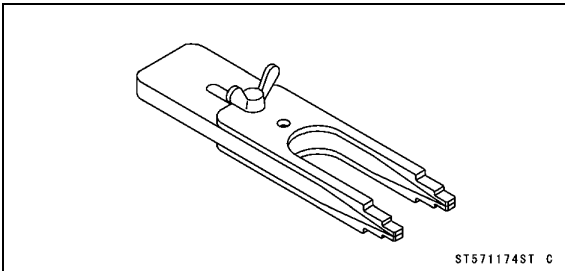

9-6 CRANKSHAFT/TRANSMISSION

Crankcase

Crankcase Disassembly

- Remove the engine from the frame (see Engine Removal in the Engine Removal/Installation chapter).
- Set the engine on clean surface while parts are being removed.
- Remove:
 - Magneto Cover (see Magneto Cover Removal in the Electrical System chapter)
 - Cylinder Head Cover (see Cylinder Head Cover Removal in the Engine Top End chapter)
 - Cylinder Head (see Cylinder Head Removal in the Engine Top End chapter)
 - Cylinder (see Cylinder Removal in the Engine Top end chapter)
 - Piston (see Piston Removal in the Engine Top End chapter)
 - Right Engine Cover (see Right Engine Cover Removal in the Engine Right Side chapter)
 - Clutch (see Clutch Removal in the Engine Right Side chapter)
 - Primary Gear (see Primary Gear Removal in the Engine Right Side chapter)
 - Balancer (see Balancer Removal)
 - Oil Pumps (see Oil Pump (Scavenge) (Feed) Removal in the Engine Lubrication System chapter)
 - Kick Shaft Assembly (see Kick Shaft Removal in the Engine Right Side chapter)
 - Kick Shaft Idle Gear (see Idle Gear Removal in the Engine Right Side chapter)
 - External Shift Mechanism (see External Shift Mechanism Removal in the Engine Right Side chapter)
 - Flywheel (see Flywheel Removal in the Electrical System chapter)
- Remove the output shaft sleeve [A] and the O-rings [B].
- Do not reuse the O-rings.

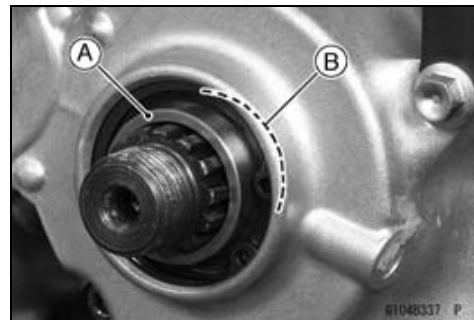

- Remove:
 - Gear Position Switch Screws [A]
 - Gear Position Switch [B]

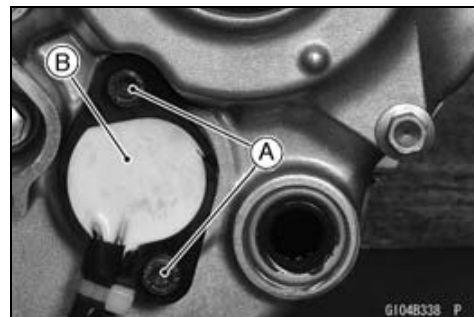

Crankcase

- Remove:
Gear Position Switch Finger Spring [A]



- Remove:
Circlip [A]
Special Tool - Outside Circlip Pliers: 57001-144

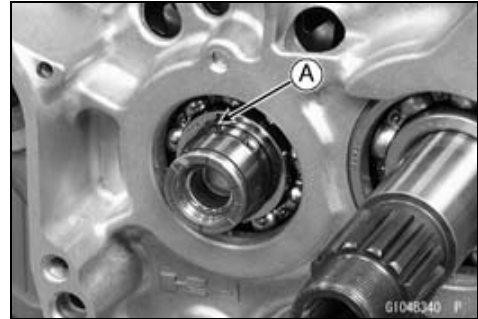

- Remove the crankcase bolts [A].

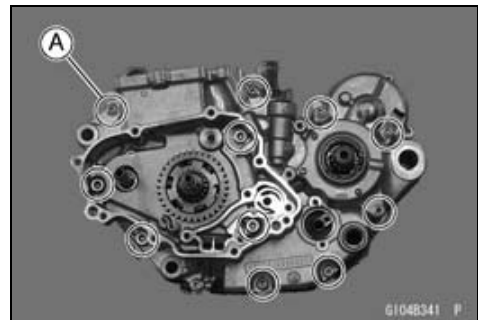

- Install the jig [A] between the crankshaft flywheels.
Special Tool - Crankshaft Jig: 57001-1174

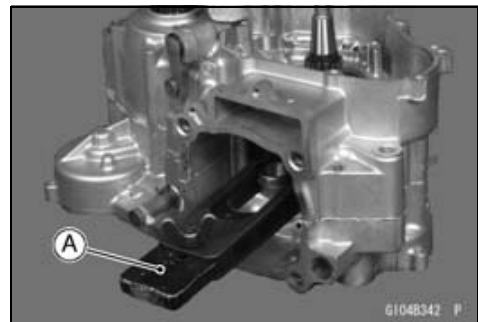

- Attach the crankcase splitting tool [A] to the left crankcase half.
Special Tool - Crankcase Splitting Tool Assembly: 57001-1362
- Tighten the center bolt of the crankcase splitting tool to split the crankcase halves.
- Remove the left crankcase half.

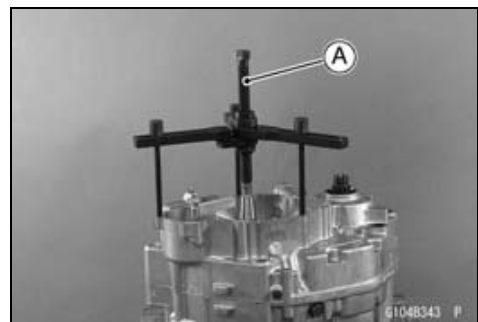

9-8 CRANKSHAFT/TRANSMISSION

Crankcase

- Remove:
 - Oil Screen (Feed) [A] (see Oil Screen (Feed) Removal in the Engine Lubrication System chapter)
 - Shift rods [B] (see Transmission Shaft Removal)
 - 2 shift forks [C] (see Transmission Shaft Removal)
 - Shift drum [D] (see Transmission Shaft Removal)
 - Transmission [E] (see Transmission Shaft Removal)
- Remove the crankshaft from the right crankcase half (see Crankshaft Removal).

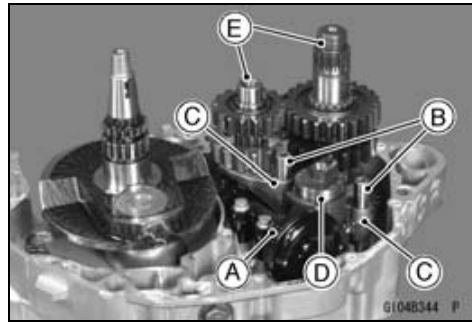

CAUTION

**Do not remove the bearings and the oil seals unless it is necessary.
Removal may damage them.**

Crankcase Assembly

CAUTION

Right and left crankcase halves are machined at the factory in the assembled state, so if replaced, they must be replaced as a set.

- Remove the old gasket from the mating surfaces of the crankcase halves and clean them off with a high-flash point solvent.
- Using compressed air, blow out the oil passages in the crankcase halves.

⚠ WARNING

Clean the engine parts in a well-ventilated area, and take care that there are no sparks or flame anywhere near the working area; this includes any appliance with a pilot light. Do not use gasoline or a low-flash point solvent to clean parts. A fire or explosions could result.

- Support the crankcase bearing boss with a suitable retainer [A].
- Using a press and the bearing driver set [C], install a new bearing [B] until it bottoms out.

Special Tool - Bearing Driver Set: 57001-1129

CAUTION

Support the crankcase bearing boss when the bearing is pressed, or the crankcase could be damaged.

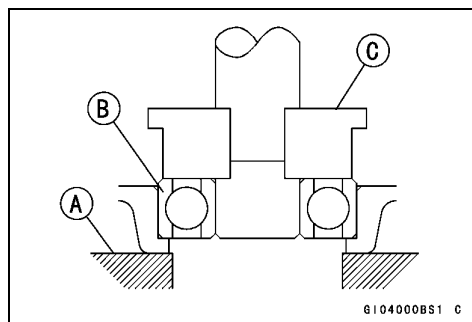

Crankcase

- Press the new transmission shaft bearing [A] in the left crankcase half, so that the sealed side [B] faces outside of the engine.

Special Tool - Bearing Driver Set: 57001-1129

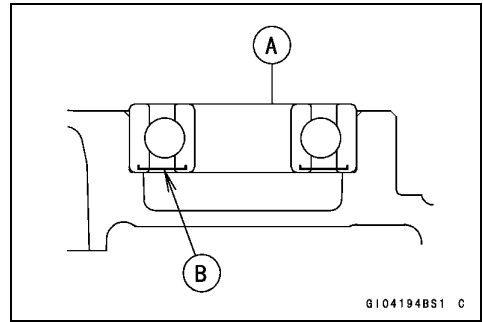

- Press the new drive shaft bearing [A] in the right crankcase [B] half, so that the stepped side [C] faces inside of the engine.

Special Tool - Bearing Driver Set: 57001-1129

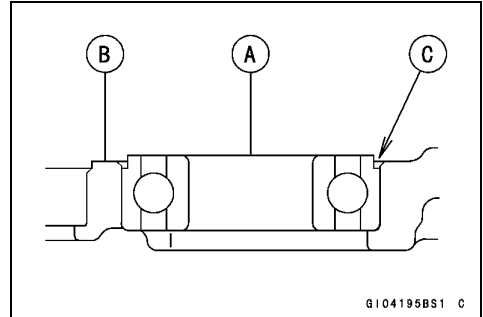

- Press the new crankshaft bearings [A] in the left and right crankcase halves [B], so that the stepped side [C] faces inside of the engine.

Special Tool - Bearing Driver Set: 57001-1129

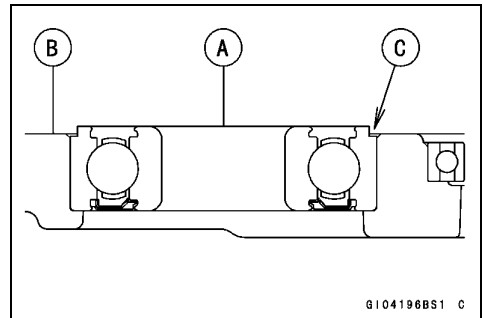

- Press the shift drum needle bearing [A] and shift shaft needle [B] bearing in the left crankcase half, so that bearing surface flush with the crankcase surface [C].

Special Tool - Bearing driver Set: 57001-1129

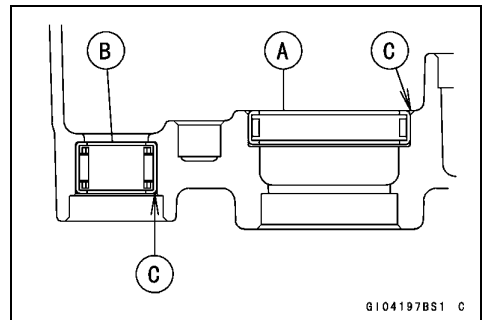

- First, press the inside release shaft needle bearing [A] until it bottom out with the bearing driver set [B].

Special Tool - Bearing driver Set: 57001-1129

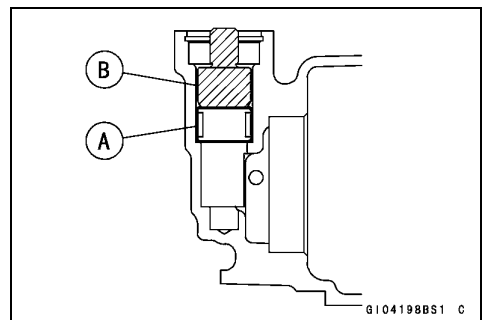

9-10 CRANKSHAFT/TRANSMISSION

Crankcase

- Next, press the outside release shaft needle bearing [A] until the surface of the bearing is even with the crankcase surface [B].

Special Tool - Bearing driver Set: 57001-1129

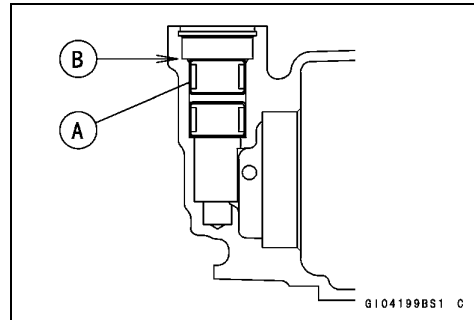

- Replace the oil seals, if removed.
- Press the output shaft and release shaft oil seals [C] so that oil seal lip [A] face to the engine outside and oil seal surface flush with the left crankcase surface [B].
- Press the shift shaft oil seal until it bottom out so that oil seal lip face the engine outside.
- Apply high-temperature grease to the oil seal lip.
- Install the new circlip [D] to the output shaft and release shaft oil seal.

Special Tool - Bearing driver Set: 57001-1129

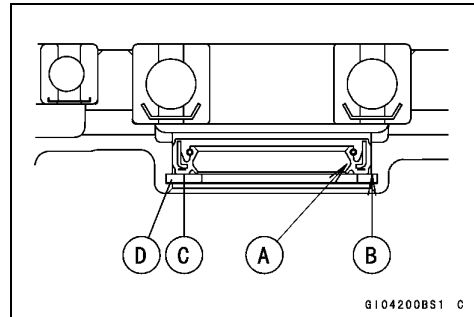

- Apply a non-permanent locking agent to the bearing retaining screw.
- Tighten the bearing retaining screws [A].

Torque - Bearing Retaining Screws: 15 N·m (1.5 kgf·m, 11 ft·lb)

Piston Oil Nozzle [B]: 2.9 N·m (0.30 kgf·m, 26 in·lb)

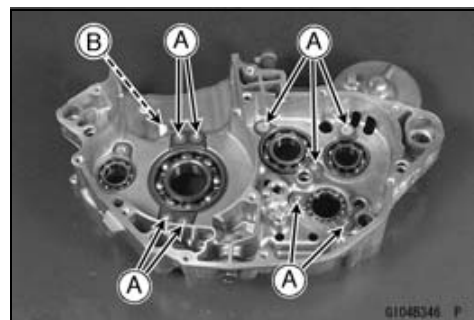
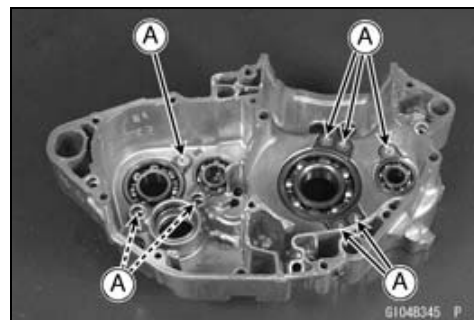

- Apply engine oil to the transmission gears, bearings, shift forks, shift drum and crankshaft bearing.
- Install the drive shaft [A] and output shaft [B] in the right crankcase half [C] as a set.

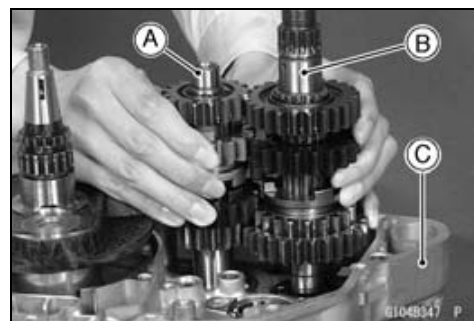

Crankcase

- Install:
 - Shift Drum [A] (see Transmission Installation)
 - Shift Rods [B] (see Transmission Installation)
 - Shift Forks [C] (see Transmission Installation)

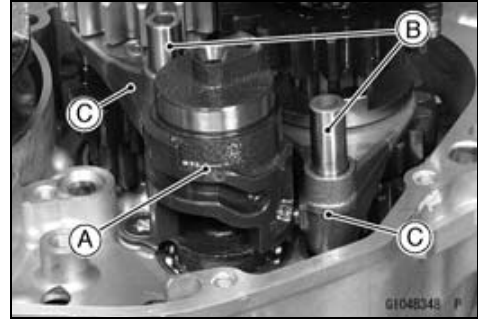

- Install:
 - Crankshaft [A]
 - Dowel Pins [B]

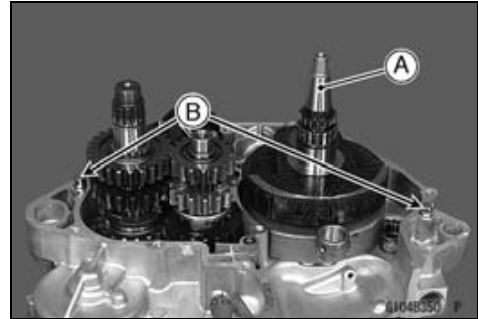

- Replace the O-ring [A] with a new one.
 - Install the Oil Screen (Feed).
- Torque - Oil Screen (Feed) Mounting Bolts: 9.8 N·m (1.0 kgf·m, 87 in·lb)**



- With the connecting rod positioned at the bottom-dead-center, install the crankshaft jig [A].
- Special Tool - Crankshaft Jig: 57001-1174**

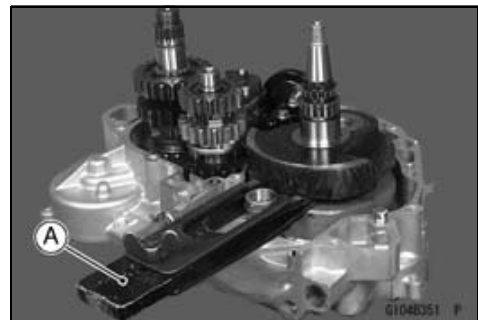

- Apply liquid gasket to the mating surface [A] of the left crankshaft half.
- Sealant - Kawasaki Bond (Liquid Gasket - Gray): 92104-1063**

NOTE

- Make the application finish within 30 minutes when the liquid gasket to the mating surface of the left crankcase half is applied.
- Moreover fit the case and tighten the case bolts just after finishing the application of the liquid gasket.

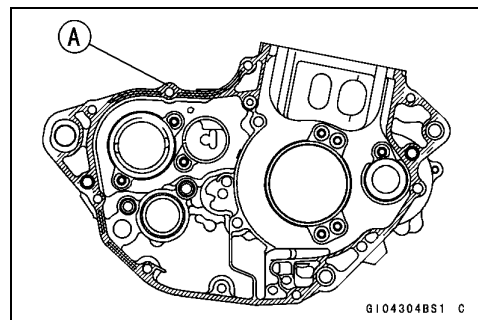

9-12 CRANKSHAFT/TRANSMISSION

Crankcase

- Using a plastic hammer [A], press [B] the rear portion of the crankcase, and tap the area around the crankshaft of the left crankcase half. While maintaining the mating surfaces of the right and left crankcase halves constantly parallel, mate the crankcase halves evenly.

NOTE

○Constantly check the alignment of the two crankcase halves, and the position of the transmission shafts, and shift drum. The front and rear of the crankcase must be pushed together evenly.

- Remove the crankshaft jig [C].
- Tighten the crankcase bolts, starting with the periphery of the crankshaft, then outward.
- Replace the copper washer installed to the bolt [B] with a new one.
- Tighten the bolt [A] with the clamp, and the bolt [B] with the copper washer.

Torque - Crankcase Bolts (M6): 12 N·m (1.2 kgf·m, 104 in·lb)

Crankcase Bolts (M7): 15 N·m (1.5 kgf·m, 11 ft·lb)

NOTE

○After tightening the crankcase bolts, wipe up the liquid gasket seeping out around the mating surface, especially around the area.

- Make sure that the crankshaft, driveshaft, and the output shaft, rotate smoothly (in the neutral position).
- ★If the crankshaft will not turn, probably the crankshaft is not centered; tap the appropriate end of the crankshaft with a mallet [A] to reposition it.

- Install the gear set lever [A].
- Fit each end [B] of the spring to original positions.
- Do not forget to install the collar and washer [C].
- Tighten the gear set lever nut [D].

Torque - Gear Set Lever Nut: 8.8 N·m (0.90 kgf·m, 78 in·lb)

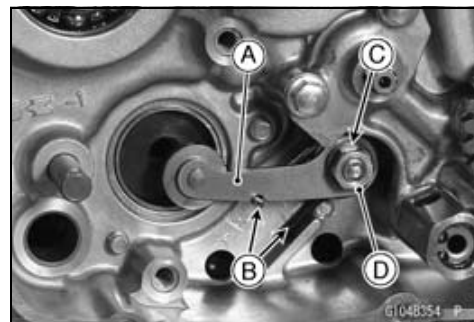
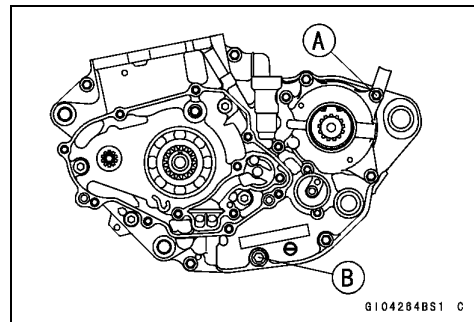
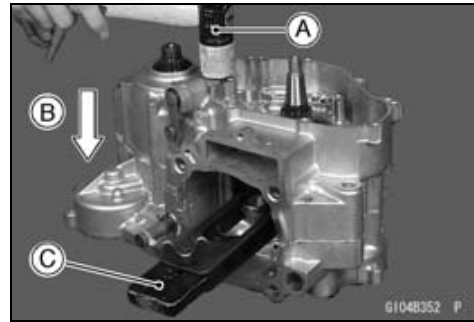

Crankcase

- To install the shift drum cam [A], use the driver [B] to bring the gear set lever [C] to the bottom of the crankcase.
- Mate the shift drum pin [D] into the shift drum hole.
- Fit the groove [E] of the shift drum cam on the shift drum pin.
- Apply non-permanent locking agent to the shift drum cam bolt and tighten it.

Torque - Shift Drum Cam Bolt: 24 N·m (2.4 kgf·m, 17 ft·lb)

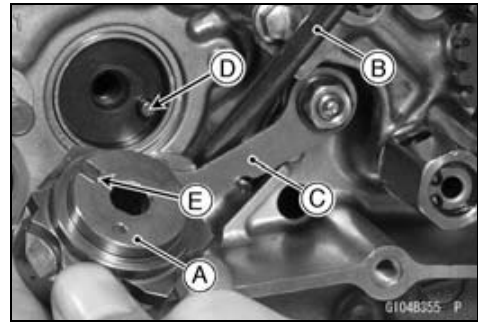

- Check to see that gears shift smoothly from 1st to 5th gear, and 5th to 1st while spinning the output shaft.
- Set the shift drum in the neutral position.

- Replace the O-rings [A] on the output shaft with new ones.
- Install two O-rings on the grinding faces of the output shaft while expanding the O-ring by the hand.
- Apply grease to the inside of the output shaft collar [B].
- Insert the collar with the oil groove end facing [C] in.

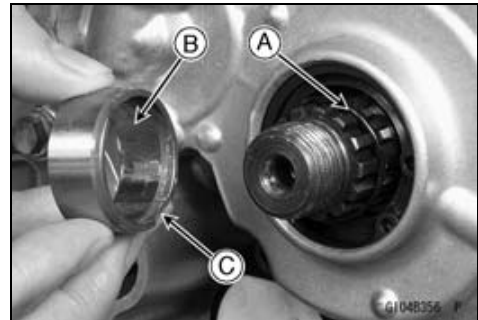

- Install the balancer drive gear [C] so that the punch mark [A] of the balancer drive gear and groove [B] of the crankshaft align.
- Replace the circlip with a new one, and install it.

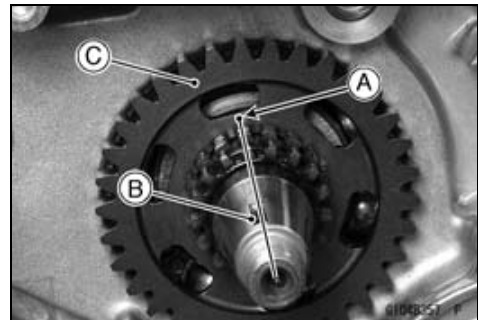

- Replace the circlip [A] with a new one, and install it to the output shaft.

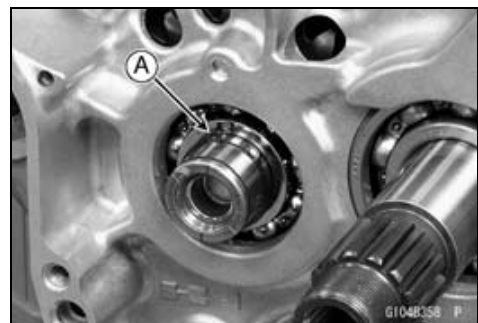

9-14 CRANKSHAFT/TRANSMISSION

Crankshaft

Crankshaft Removal

- Disassemble the crankcase (see Crankcase Disassembly).
- Using the hand pull out the crankshaft [A] from the right crankcase half [B].

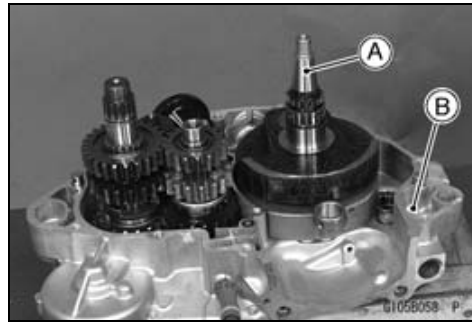

Crankshaft Installation

- Apply high-temperature grease to the outer side of the crankshaft bearings and use the bearing driver set [C] to face the stepped side [A] to the engine inside and drive the bearing to the bottom of the crankcase [B]. While driving the bearing in, make sure to use a holder to support the boss area.

Special Tool - Bearing Driver Set: 57001-1129

- Install the crankshaft to the right crankcase half.
- Apply engine oil to the connecting rod big end bearing.

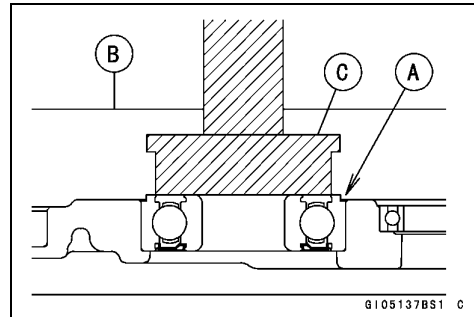

Crankshaft Disassembly

Since assembly of the crankshaft demands exacting tolerances, the disassembly and reassembly of the crankshaft can only be done by a shop having the necessary tools and equipment.

- If it should be necessary to disassemble the crankshaft, use a press to remove the crankpin.

Crankshaft Assembly

Since the assembly of the crankshaft demands exacting tolerances, the disassembly and reassembly of the crankshaft can only be done by a shop having the necessary tools and equipment.

- Carefully align the oil passage hole in the right flywheel [A] with the one in the crankpin [B] at rebuilding of the crankshaft as shown.

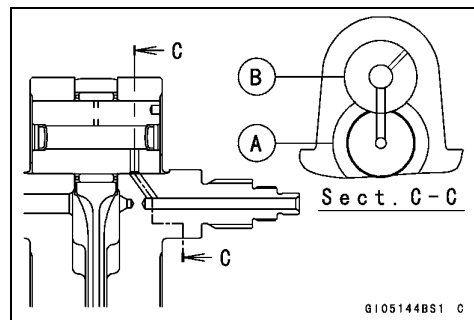

- Reassemble the crankshaft according to the standard tolerances in Specifications.
 - Connecting rod bend, twist.
 - Connecting rod big end radial clearance.
 - Cold-fitting tolerance between crankpin and flywheels.
 - Side clearance between the connecting rod big end and one of flywheels.
 - Crankshaft runout.

Crankshaft

Crankshaft Inspection

Connecting Rod Big End Radial Clearance Inspection

- Set the crankshaft on V blocks, and place a dial gauge [A] against the connecting rod big end.
- Push [B] the connecting rod first towards the gauge and then in the opposite direction. The difference between two gauge readings is the radial clearance.

Connecting Rod Big End Radial Clearance

Standard: 0.002 mm ~ 0.014 mm (0.00008 ~ 0.0006 in.)

Service Limit: 0.06 mm (0.002 in.)

- ★ If the radial clearance exceeds the service limit, crankshaft should be either replaced or disassembled and crankpin, needle bearing, and connecting rod big end should be examined for wear.

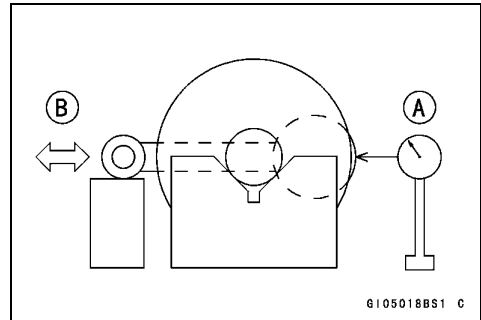

Connecting Rod Big End Side Clearance Inspection

- Measure the connecting rod big end side clearance [A].

Connecting Rod Big End Side Clearance

Standard: 0.25 ~ 0.35 mm (0.0098 ~ 0.014 in.)

Service Limit: 0.6 mm (0.02 in.)

- ★ If the clearance exceeds the service limit, replace the crankshaft assembly.

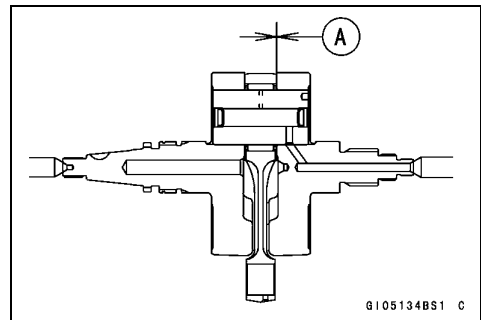

Crankshaft Runout Inspection

- Set the crankshaft in a flywheel alignment jig or on V blocks, and place a dial gauge as shown and turn the crankshaft slowly. The maximum difference in gauge reading is the crankshaft runout.

Standard: TIR 0.03 mm (0.0012 in.) or less

Service Limit: TIR 0.08 mm (0.0031 in.)

- ★ If the runout at either point exceeds the service limit, replace the crankshaft assembly with a new one or align the crankshaft so that the runout falls within the service limit. 8.5 mm (0.33 in.) [A]

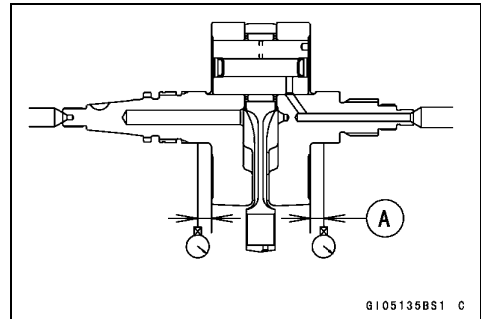

- First correct the horizontal misalignment by striking the projecting crank half [A] with a plastic, soft lead, or brass hammer as shown.
- Recheck the runout with a dial gauge and repeat the process until the runout falls within the service limit.

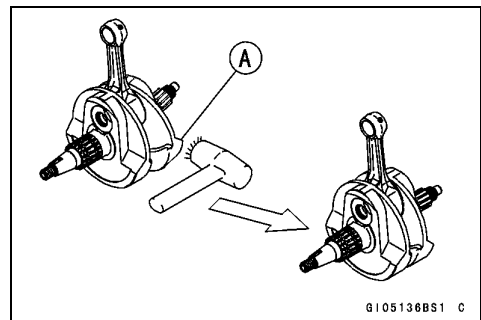

9-16 CRANKSHAFT/TRANSMISSION

Crankshaft

- Next, correct the vertical misalignment by either driving a wedge [A] in between the crank halves or by squeezing them in a vice, depending on the nature of the misalignment.

CAUTION

Do not hammer the crank half at the point [B].

- ★ If flywheel misalignment cannot be corrected by the above method, replace the crank pin or the crankshaft itself.

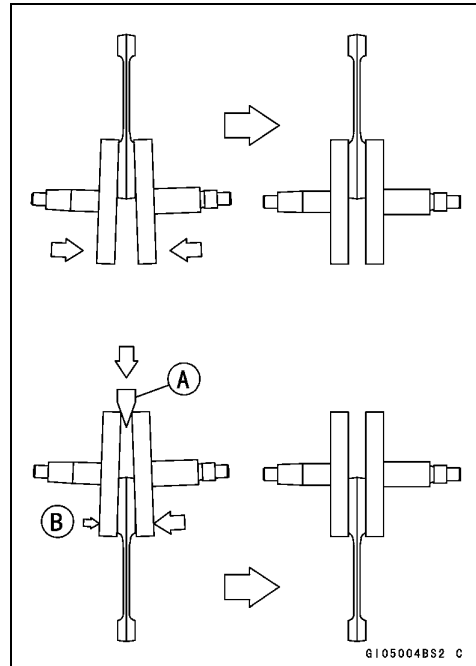

Connecting Rod Big End Seizure Inspection

- ★ In case of serious seizure with damaged flywheels, the crankshaft must be replaced.
- ★ In case of less serious damage, disassemble the crankshaft and replace the crankpin, needle bearing, and connecting rod.

Connecting Rod Bend Inspection

- Remove the connecting rod.
- Select an arbor [A] of the same diameter as the connecting rod big end, and insert the arbor through the connecting rod big end.
- Select an arbor of the same diameter as the piston pin and more than 105 mm long, and insert the arbor [B] through the connecting rod small end.
- On a surface plate, set the big-end arbor on a V block [C].

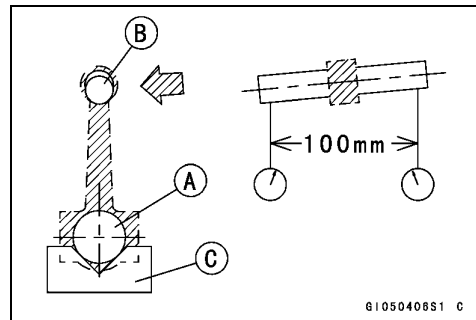

- With the connecting rod held vertically, use a height gauge to measure the difference in the height of the arbor above the surface plate over a 100 mm length to determine the amount of connecting rod bend.
- ★ If connecting rod bend exceeds the service limit, the connecting rod must be replaced.

Connecting Rod Bend

Service Limit: TIR 0.2/100 mm (0.08/3.94 in.)

Crankshaft

Connecting Rod Twist Inspection

- With the big-end arbor [A] still on the V block [C], hold the connecting rod horizontally and measure the amount that the arbor [B] varies from being parallel with the surface plate over a 100 mm length of the arbor to determine the amount of connecting rod twist.
- ★ If connecting rod twist exceeds the service limit, the connecting rod must be replaced.

Connecting Rod Twist

Service Limit: TIR 0.2/100 mm (0.08/3.94 in.)

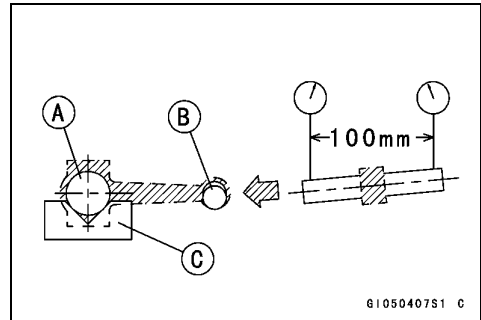

9-18 CRANKSHAFT/TRANSMISSION

Transmission

Transmission Shaft Removal

- Disassemble the crankcase (see Crankcase Disassembly).
- Pull out the shift rods [A] allowing the shift fork guide pins to free from the shift drum [B].
- Remove the shift fork [C].
- Remove the shift drum.

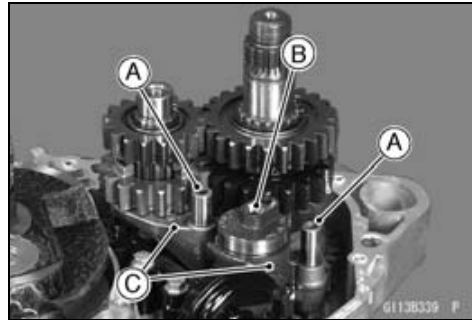

- Pull out the drive shaft [A] and output shaft [B] together with their gears meshed.

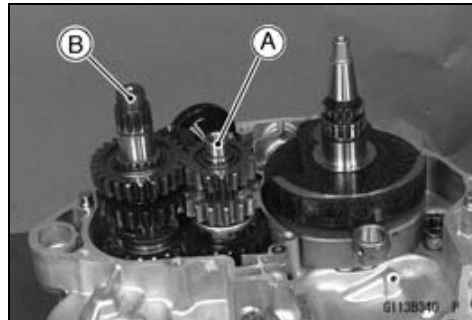

Transmission Shaft Installation

- Apply engine oil to the sliding portion of the transmission shaft, gears, and ball bearings.
- Install the drive shaft [A] and output shaft [B] in the right crankcase half [C] with their gears meshed.
- Install the shift drum.

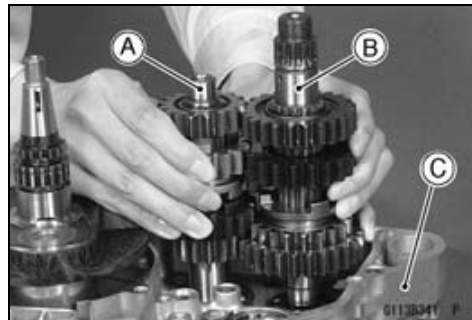

- Apply a small amount of engine oil to the shift fork fingers and fit each shift fork into the groove of the proper gear.
- The shift forks can be identified by their shape or mark. Install them noting the direction shown.
- Install each shift forks with its mark [A] facing the engine left side.

Marks: 020 (Drive shaft)
 021 (Output shaft)

- Assembly the crankcase (see Crankcase Assembly).
- Fit each shift fork guide pin into the corresponding groove in the shift drum.
- Apply a small amount of engine oil to the shift rods and slide them into the shift forks.
- Assembly the crankcase (see Crankcase Assembly).

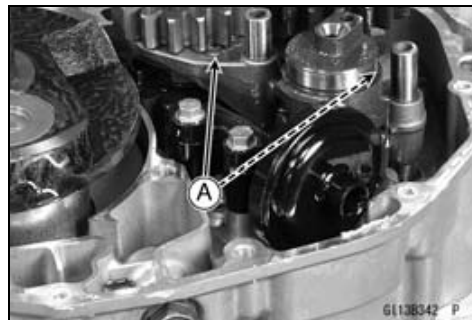

Transmission Shaft Disassembly

- Remove the transmission shafts.
- Remove the circlips, washers, then gears.

Special Tool - Outside Circlip Pliers: 57001-144

- Do not reuse the removed circlips.

Transmission

Transmission Shaft Assembly

- Apply engine oil liberally to the transmission shaft, gears and bearings.
- Replace any circlips that were removed with new ones.
- Always install the circlips [A] so that the opening [B] is aligned with a spline groove [C], and install toothed washers. To install a circlip without damage, first fit the circlip onto the shaft expanding it just enough to install it, and then use a suitable gear to push the circlip into place.

Special Tool - Outside Circlip Pliers: 57001-144

- The drive shaft gears can be identified by size; the smallest diameter gear is 1st gear, and the largest is 4th. Be sure that all parts are put back in the correct sequence, facing the proper direction, and that all circlips and the washers are properly in place.
- The output shaft gears can be identified by size; the largest diameter gear is 1st gear, and the smallest is 5th. Be sure that all parts are put back in the correct sequence, facing the proper direction, and that all circlips and washers are properly in place.

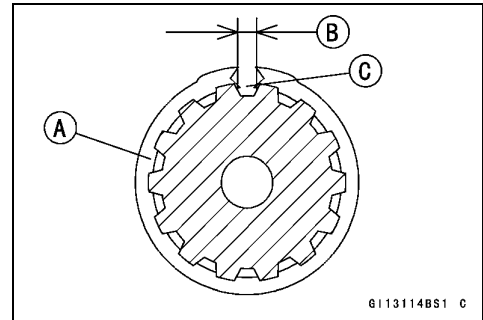

9-20 CRANKSHAFT/TRANSMISSION

Transmission

KX450D6F

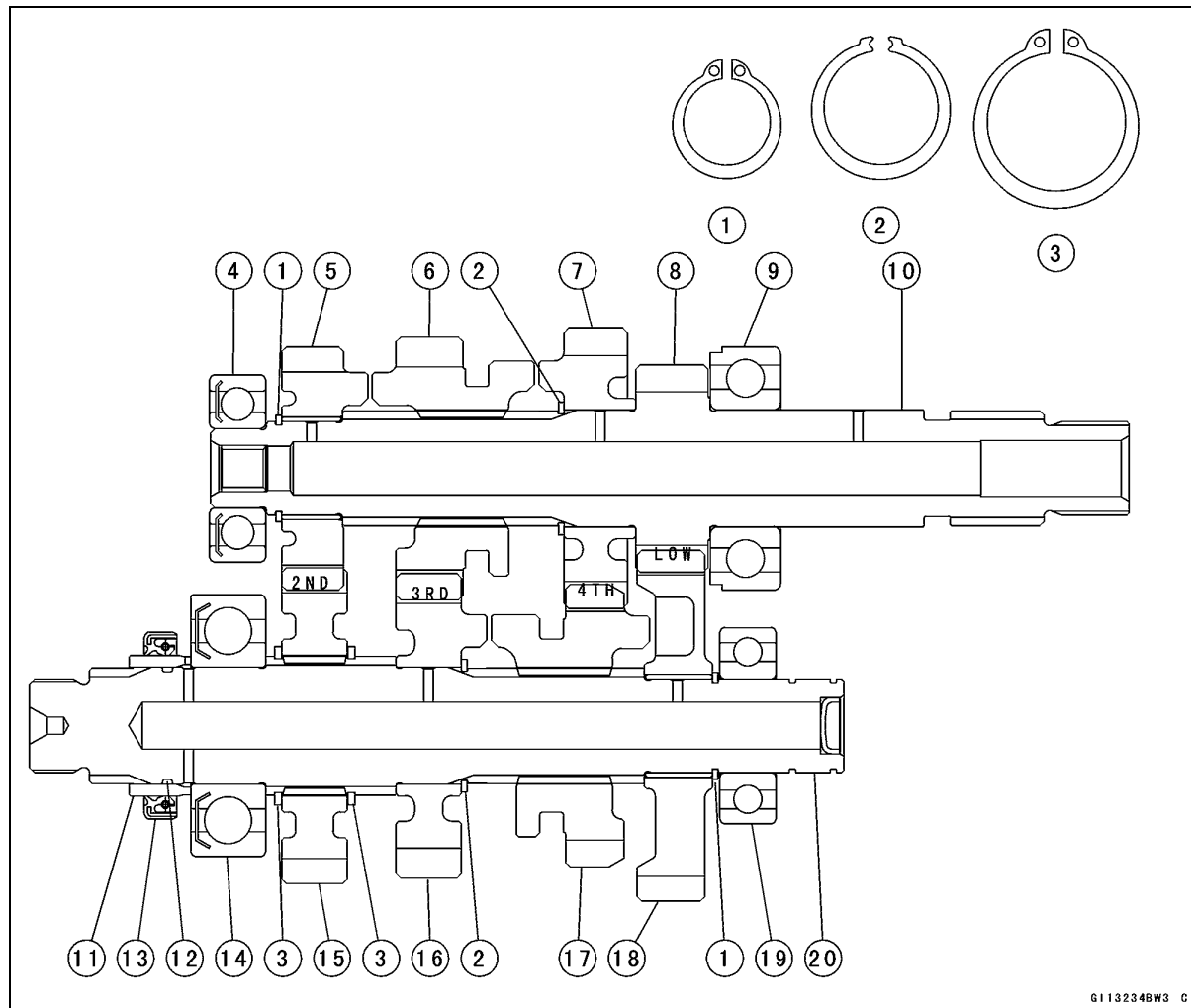

- | | |
|-----------------------------------|------------------------------------|
| 1. Circlip (small) | 11. Collar |
| 2. Circlip (middle) | 12. O-rings (2) |
| 3. Circlip (large) | 13. Oil Seal |
| 4. Ball Bearing (one side sealed) | 14. Ball Bearing (one side sealed) |
| 5. 2nd Gear (17T) | 15. 2nd Gear (24T) |
| 6. 3rd Gear (16T) | 16. 3rd Gear (19T) |
| 7. 4th Gear (19T) | 17. 4th Gear (19T) |
| 8. 1st Gear (15T) | 18. 1st Gear (27T) |
| 9. Ball Bearing | 19. Ball Bearing |
| 10. Drive Shaft | 20. Output Shaft |

- Check each gear spins or slides freely on the transmission shaft without binding after assembly.

Transmission

KX450D7F ~

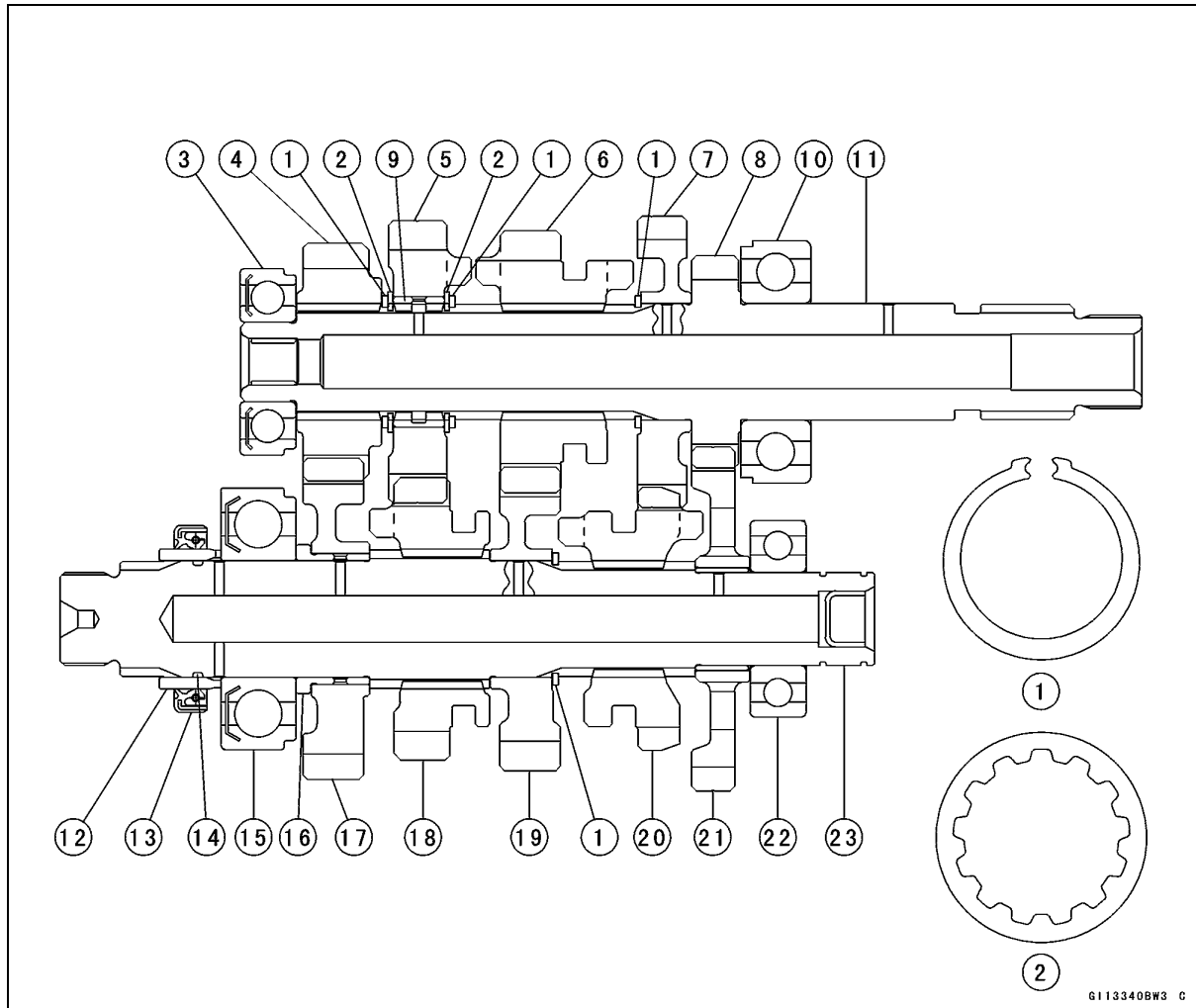

G113340BWS C

- | | |
|-----------------------------------|------------------------------------|
| 1. Circlip | 13. Oil Seal |
| 2. Toothed Washer | 14. O-rings |
| 3. Ball Bearing (one side sealed) | 15. Ball Bearing (one side sealed) |
| 4. 2nd Gear (17T) | 16. Collar |
| 5. 4th Gear (19T) | 17. 2nd Gear (24T) |
| 6. 3rd Gear (16T) | 18. 4th Gear (19T) |
| 7. 5th Gear (24T) | 19. 3rd Gear (19T) |
| 8. 1st Gear (16T) | 20. 5th Gear (21T) |
| 9. Bushing | 21. 1st Gear (28T) |
| 10. Ball Bearing | 22. Ball Bearing |
| 11. Drive Shaft | 23. Output Shaft |
| 12. Collar | |

- Check each gear spins or slides freely on the transmission shaft without binding after assembly.

9-22 CRANKSHAFT/TRANSMISSION

Transmission

Shift Fork Bending Inspection

- Visually inspect the shift forks, and replace any fork that is bent. A bent fork may cause difficulty in shifting, or allow the transmission to jump out of gear when under power.
90° [A]

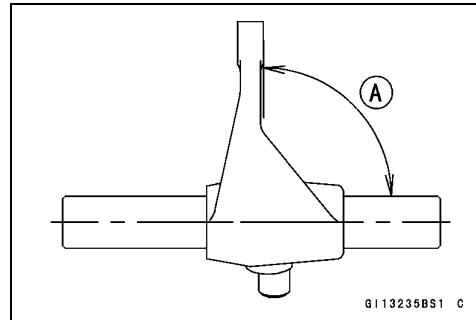

Shift Fork/Gear Groove Wear Inspection

- Measure the thickness [A] of the shift fork ears, and measure the width [B] of the gear grooves (with which the fork engages).

Shift Fork Ear Thickness

Standard: 4.9 ~ 5.0 mm (0.193 ~ 0.197 in.)

Service Limit: 4.8 mm (0.19 in.)

Gear Groove Width

Standard: 5.05 ~ 5.15 mm (0.199 ~ 0.203 in.)

Service Limit: 5.25 mm (0.207 in.)

- ★ If the thickness of a shift fork ear is less than the service limit, the shift fork must be replaced.
- ★ If the gear groove is worn exceeding the service limit, the gear must be replaced.

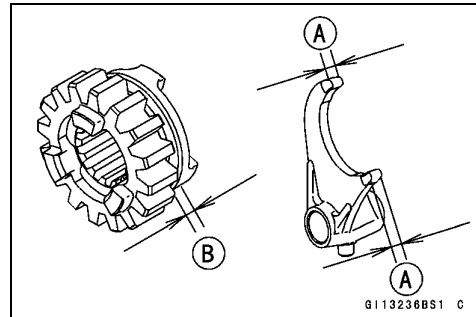

Shift Fork Guide Pin/Shift Drum Groove Wear Inspection

- Measure the diameter of each shift fork guide pin [A], and measure the width [B] of each shift drum groove.

Shift Fork Guide Pin Diameter

Standard: 5.9 ~ 6.0 mm (0.232 ~ 0.236 in.)

Service Limit: 5.8 mm (0.228 in.)

Shift Drum Groove Width

Standard: 6.05 ~ 6.20 mm (0.238 ~ 0.244 in.)

Service Limit: 6.3 mm (0.25 in.)

- ★ If the guide pin on any shift fork is less than the service limit, the fork must be replaced.
- ★ If any shift drum groove is worn exceeding the service limit, the drum must be replaced.

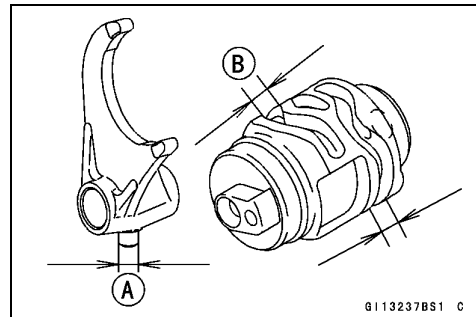

Gear Damage Inspection

- Visually inspect the gear dogs [A] and gear dog holes [B].
- ★ Replace any damaged gears or gears with excessively worn dogs or dog holes.
- Visually inspect the gear teeth [C] on the transmission gears.
- ★ Replace lightly damaged gear teeth with an oilstone. The gear must be replaced if the teeth are badly damaged.
- ★ When gear is repaired or replaced, the driving gear should also be inspected and repaired or replaced if necessary.

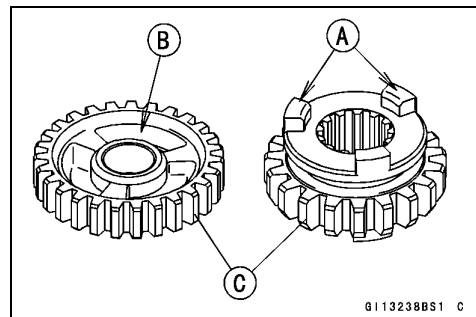

Balancer

Balancer Removal

- Remove:
 - Right Engine Cover (see Right Engine Cover Removal in the Engine Right Side chapter)
 - Magneto Cover (see Magneto Cover Removal in the Electrical System chapter)
 - Flywheel (see Flywheel Removal in the Electrical System chapter)
 - Balancer Weight Mounting Nut [A]
 - Balancer Weight [B]
 - Balancer Gear [C]
- Pull out the balancer shaft from the right crankcase half.

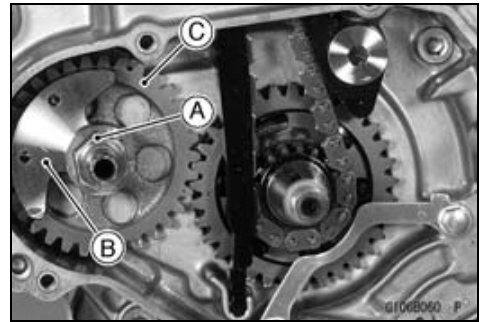

Balancer Installation

- Insert the balancer shaft from the right crankcase half.
- Install the balancer gear so that the stepped portion [A] on the balancer shaft and punch mark [B] on the balancer gear align.
- Align the punch mark [A] on the balancer drive gear and punch mark [B] on the balancer gear.

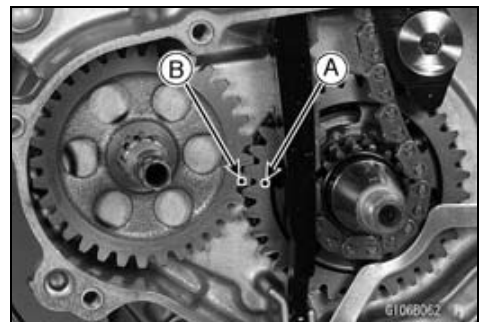
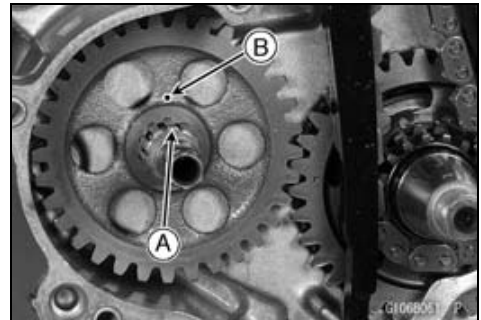

- Install the balancer weight so that the punch mark [A] on the balancer and punch mark [B] on the balancer gear.
- Tighten:
 - Torque - Balancer Weight Mounting Nut: 52 N·m (5.3 kgf·m, 38 ft·lb)**

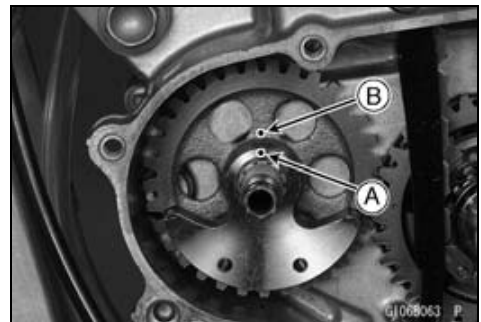

9-24 CRANKSHAFT/TRANSMISSION

Bearings/Oil Seals

Bearing Replacement

CAUTION

Do not remove the ball bearings unless it is necessary. Removal may damaged them.

- Remove the ball bearing and/or needle bearing outer race using a press or puller.

NOTE

○ *In the absence of the above mentioned tools, satisfactory results may be obtained by heating the case to approximately 93°C (200°F) max, and tapping the bearing in or out.*

CAUTION

Do not heat the case with a torch. This will warp the case. Soak the case in oil and heat the oil.

- Install the new bearing until its outer race stops at the bottom of the case using a press and the bearing driver set [A].

Special Tool - Bearing Driver Set: 57001-1129

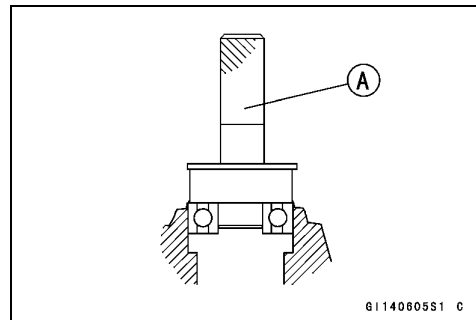

Bearing Inspection

CAUTION

Do not remove the bearings for inspection. Removal may damage them.

- Inspect the ball bearings.
- Since the ball bearings are made to extremely close tolerances, the wear must be judged by feel rather than measurement. Clean each bearing in a high-flash point solvent, dry it (do not spin the bearing while it is dry), and oil it with engine oil to it.
- Spin [A] the bearing by hand to check its condition.
- ★ If the bearing is noisy, does not spin smoothly, or has any rough spots, replace it.

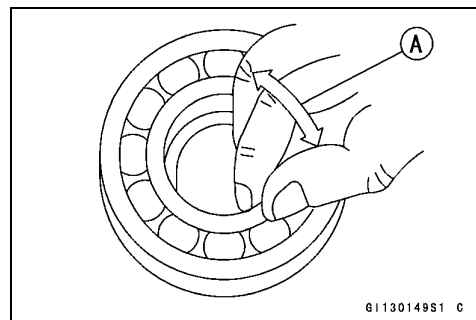

Bearings/Oil Seals

- Check the needle bearing.
- The rollers in a needle bearing normally wear very little, and wear is difficult to measure. Instead of measuring, inspect the bearing for abrasion, color change, or other damage.
- ★ If there is any doubt as to the condition of a needle bearing, replace it.

Oil Seal Inspection

- Inspect the oil seal.
- ★ Replace the oil seal if the lips are deformed, discolored (indicating that the rubber has deteriorated), hardened or otherwise damaged.

Wheels/Tires

Table of Contents

Exploded View	10-2
Specifications	10-4
Special Tools	10-5
Wheels (Rims)	10-6
Front Wheel Removal	10-6
Front Wheel Installation	10-6
Rear Wheel Removal	10-7
Rear Wheel Installation	10-8
Wheels Inspection	10-9
Spoke Tightness Inspection	10-9
Rim Runout Inspection	10-9
Axle Inspection	10-10
Tires	10-11
Tire Removal	10-11
Tire Installation	10-12
Air Pressure Inspection/Adjustment	10-13
Hub Bearings	10-14
Hub Bearing Removal	10-14
Hub Bearing Installation	10-14
Hub Bearing Inspection	10-14

10-2 WHEELS/TIRES

Exploded View

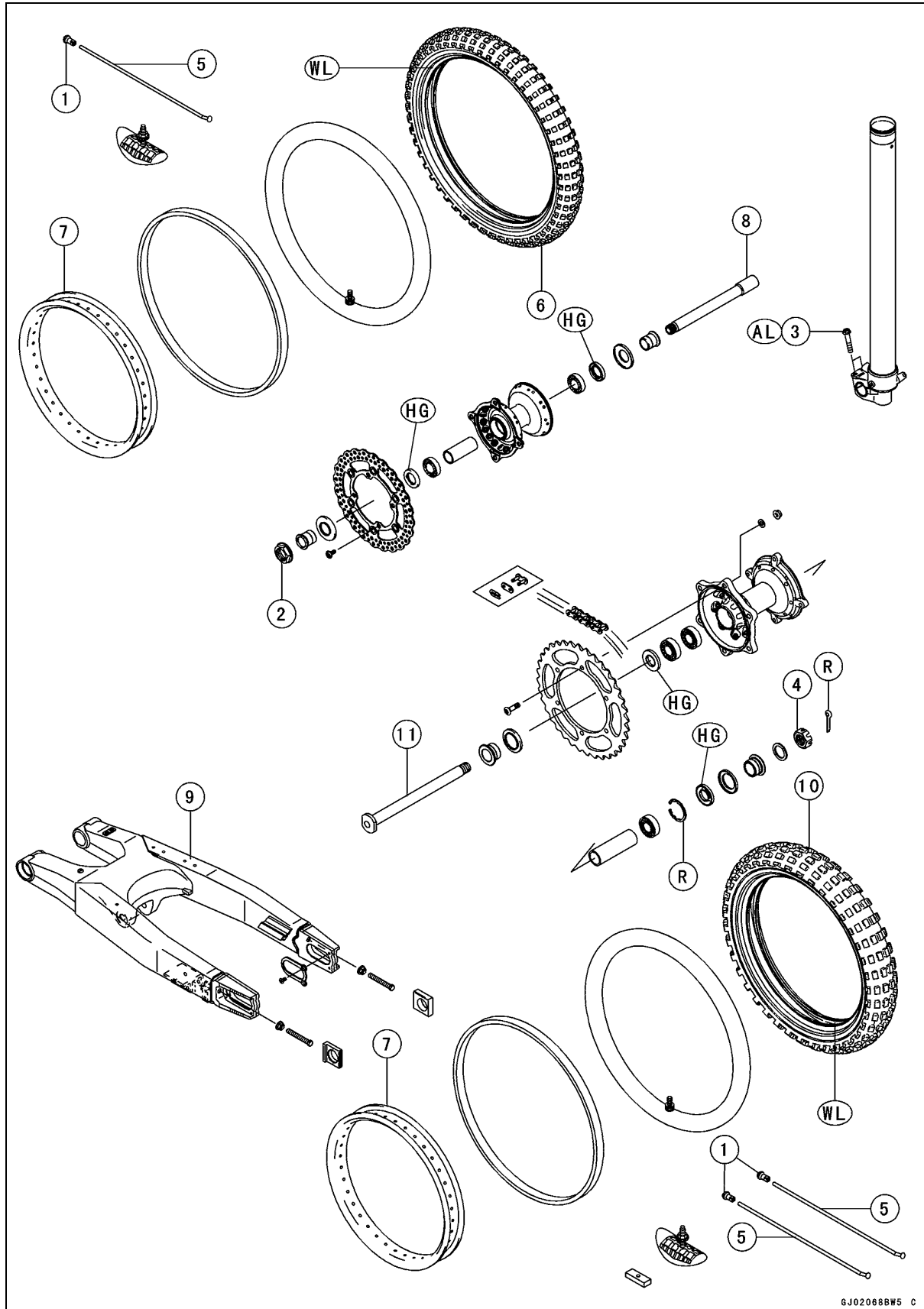

Exploded View

No.	Fastener	Torque			Remarks
		N·m	kgf·m	ft·lb	
1	Spoke Nipples	Not less than 2.2	Not less than 0.22	Not less than 19 in·lb	
2	Front Axle Nut	78	8.0	58	
3	Front Axle Clamp Bolts	20	2.0	15	AL
4	Rear Axle Nut	108	11	80	

5. Spokes

6. Front Tire

7. Rims

8. Front Axle

9. Swingarm

10. Rear Tire

11. Rear Axle

AL: Tighten the two clamp bolts alternately two times to ensure even tightening torque.

HG: Apply high temperature grease.

WL: Apply soap and water solution, or rubber lubricant.

10-4 WHEELS/TIRES

Specifications

Item	Standard	Service Limit
Wheels (Rims)		
Rim Runout (with tire installed):		
Axial	TIR 1.0 mm (0.039 in.) or less	TIR 2 mm (0.08 in.)
Radial	TIR 1.0 mm (0.039 in.) or less	TIR 2 mm (0.08 in.)
Axle Runout/100 mm (3.94 in.)	TIR 0.1 mm (0.004 in.) or less	TIR 0.2 mm (0.008 in.)
Rim Size:		
Front	21 × 1.60	— — —
Rear	19 × 2.15	— — —
Tires Air Pressure		
Front and Rear	100 kPa (1.0 kgf/cm ² , 14 psi)	— — —
Tires		
Standard Tire:		
Front:		
Size	90/100-21 57M	— — —
Make	DUNLOP	
Type	D742F, Tube	
Rear:		
Size	120/80-19 63M	— — —
Make	DUNLOP	
Type	D756, Tube	

Special Tools

Inside Circlip Pliers:
57001-143

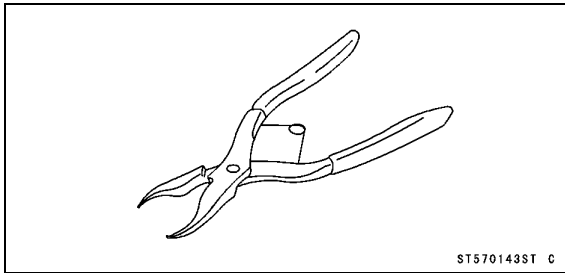

Bearing Driver Set:
57001-1129

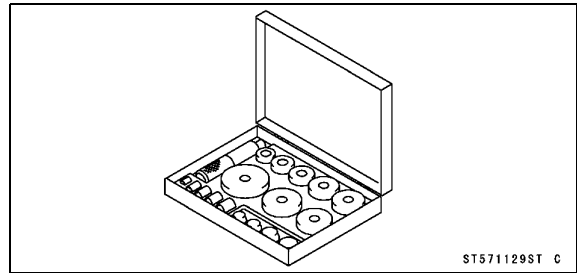

Rim Protector:
57001-1063

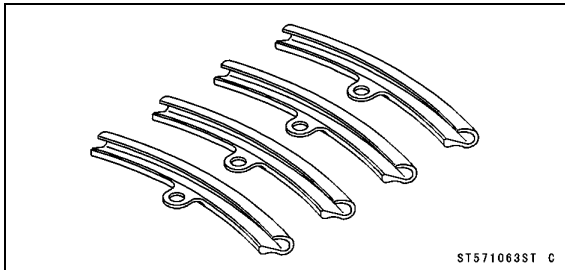

Jack:
57001-1238

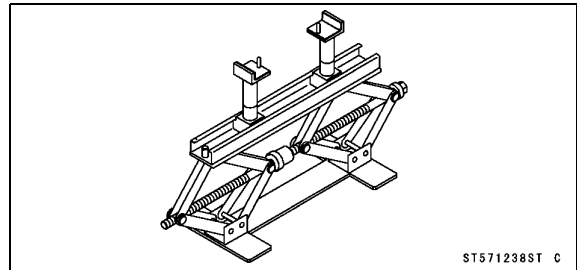

Bead Breaker Assembly:
57001-1072

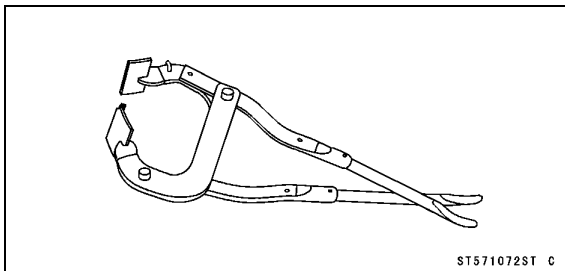

10-6 WHEELS/TIRES

Wheels (Rims)

Front Wheel Removal

- Using the jack [A] under the frame, and stabilize the motorcycle.

Special Tool - Jack: 57001-1238

- Apply the rear brake to rear wheel so that it does not turn.

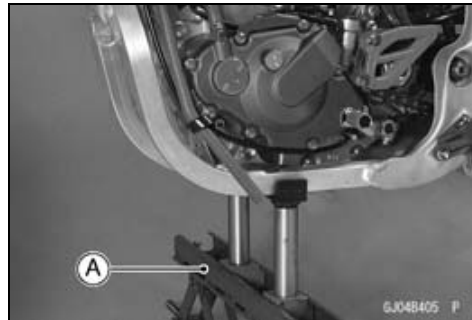

- Unscrew the axle nut [A].
- Loosen the left and right axle clamp bolts [B].
- Place a commercially available jack under the engine to raise the front wheel off the ground.
- Remove the axle [C], and pull out the wheel. Take off the collars and caps [D] from each side of the front hub.

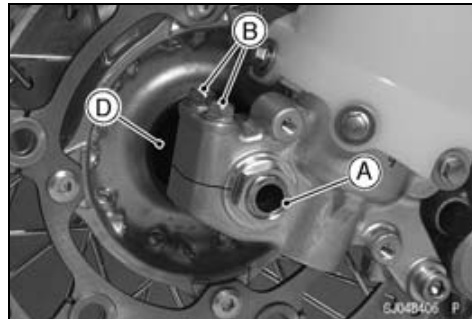

CAUTION

Do not lay the wheel on the ground with the disc facing down. This can damage or warp the disc. Place blocks under the wheel so the disc does not touch the ground.

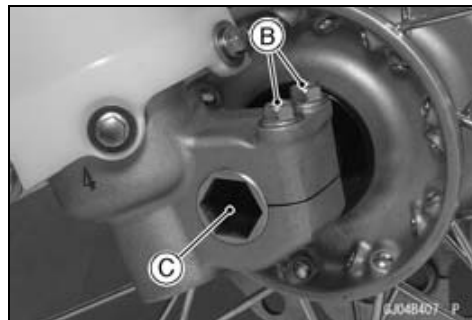

- Insert a wood wedge between the disc brake pads this prevents them from being moved out of their proper position, should the brake lever be squeezed accidentally.

Front Wheel Installation

- Apply grease to the seals.
- Fit the projection [A] on the cap to the groove [B] on the collar.
- Install the caps and collars on the left and right side of the hub.

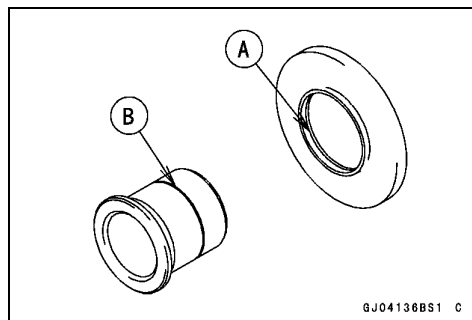

Wheels (Rims)

- Insert the axle [A] from right side.
- Tighten the right [B] axle clamp bolts temporarily.
- Tighten the axle nuts [C].
- Tighten the left axle clamp bolts [D].

Torque - Front Axle: 78 N·m (8.0 kgf·m, 58 ft·lb)

Left Axle Clamp Bolts: 20 N·m (2.0 kgf·m, 15 ft·lb)

NOTE

- Tighten the two clamp bolts alternately two times to ensure even tightening torque.

- Remove the jack.
- Before tightening the right clamp bolts on the right fork leg, pump the forks up and down [A] 4 or 5 times to allow the right fork leg to find a neutral position on the front axle.

NOTE

- Do not apply the front brake during this process to stop the motorcycle from rolling forward. Put a block [B] in front of the wheel to stop it from moving.

- Tighten the right axle clamp bolts.

Torque - Right Axle Clamp Bolts: 20 N·m (2.0 kgf·m, 15 ft·lb)

NOTE

- Tighten the two clamp bolts alternately two times to ensure even tightening torque.

- Check the front brake for good braking power and no brake drag.

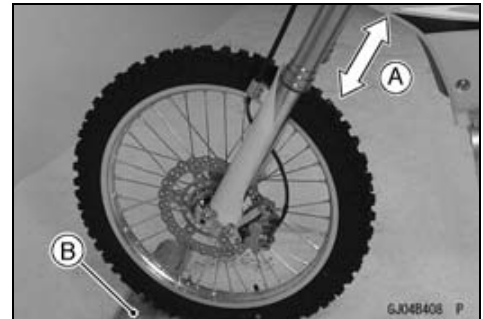
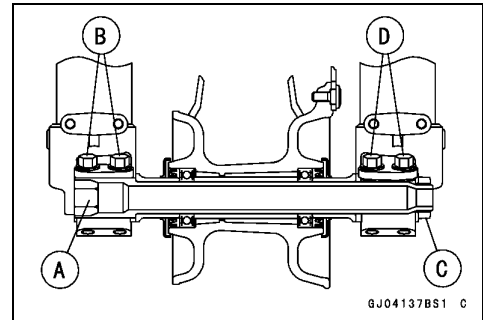

⚠ WARNING

Do not attempt to drive the motorcycle until a full brake lever is obtained by pumping the brake lever until the pads are against the disc. The brake will not function on the first application of the lever if this is not done.

Rear Wheel Removal

- Using the jack under the frame so that the rear wheel is raised off the ground.

Special Tool - Jack: 57001-1238

- Remove the clip [A] from the master link using pliers, and free the drive chain [B] from the rear sprocket.

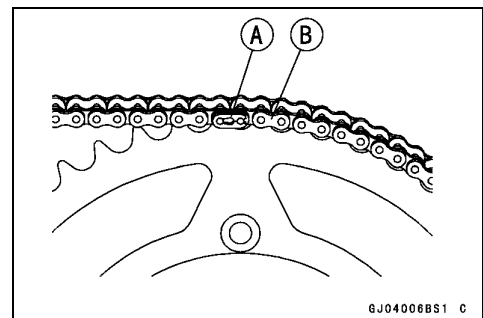

10-8 WHEELS/TIRES

Wheels (Rims)

- Remove
 - Cotter Pin [A]
 - Axle Nut [B]
- Pull out the axle [C].
- Move the rear wheel back with the rear caliper installed.
- Take off the collar and cap from the each side of the rear hub.

CAUTION

Do not lay the wheel on the ground with the disc facing down. This can damage or warp the disc. Place blocks under the wheel so the disc does not touch the ground.

- Insert a wood wedge between the brake pads. This prevents them from being moved out of their proper position, should the brake pedal be squeezed accidentally.

Rear Wheel Installation

- Fit the brake holder stop [A] with the stop grooves [B] against the swingarm stop space [C] with the stop projection [D].

- Fit the projection on the cap to the groove on the collar.
- Install the collars [A] on the left and right side of the hub.
 - The collars are identical.

- Install the drive chain. Install the master link clip [A] so that the closed end [B] of the "U" points in the direction of chain rotation [C].

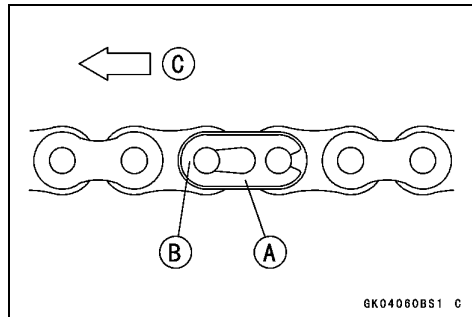
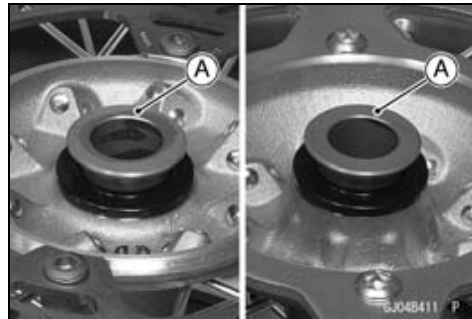
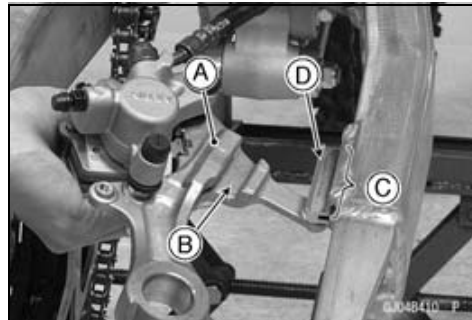
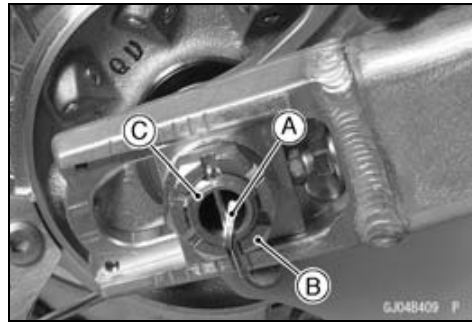

Wheels (Rims)

- Check the drive chain slack (see Drive Chain Slack Inspection in the Periodic Maintenance chapter).
- Tighten the axle nut.
 - Torque - Rear Axle Nut: 108 N·m (11 kg·m, 80 ft·lb)**
- Install the new cotter pin [A] and spread its end.

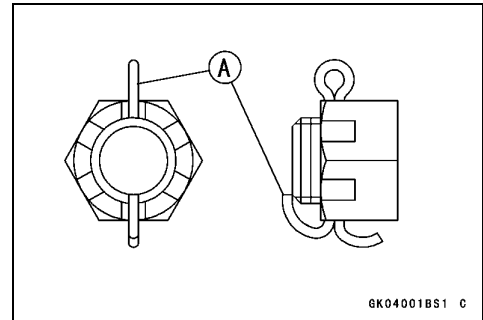

NOTE

- When inserting the cotter pin, if the slots in the nut do not align with the cotter pin hole in the axle shaft, tighten the nut clockwise [A] up to next alignment.
- It should be within 30 degree.
- Loosen one and tighten again when the slot goes past the nearest hole.

⚠ WARNING

If the axle nut is not securely tightened, or the cotter pin is not installed, an unsafe riding condition may result.

- Install the disc cover.
- Check the rear brake for good braking power and no brake drag.

⚠ WARNING

Do not attempt to drive the motorcycle until a full brake pedal is obtained by pumping the brake pedal until the pads are against the disc. The brake will not function on the first application of the pedal if this is not done.

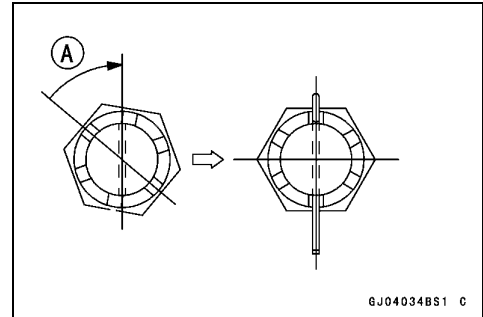

Wheels Inspection

- Place the jack under the frame so that the front/rear wheel is raised off the ground.

Special Tool - Jack: 57001-1238

- Spin the wheel lightly, and check for roughness or binding.
- ★ If the roughness or binding is found, replace the hub bearings.
- Visually inspect the front and rear axles for damage.
- ★ If the axle is damaged or bent, replace it.

Spoke Tightness Inspection

- Refer to the Spoke Tightness Inspection in the Periodic Maintenance chapter.

Rim Runout Inspection

- Refer to the Rim Runout Inspection in the Periodic Maintenance chapter.

10-10 WHEELS/TIRES

Wheels (Rims)

Axle Inspection

- Visually inspect the front and rear axle for damages.
- ★ If the axle is damaged or bent, replace it.
- Place the axle in V blocks that are 100 mm (3.937 in.) [A] apart, and set a dial gauge on the axle at a point halfway between the blocks. Turn the axle to measure the runout. The difference between the highest and lowest dial readings is the amount of runout.
- ★ If the runout exceeds the service limit, replace the axle.

Axle Runout/100 mm (3.94 in.)

Standard: TIR 0.1 mm (0.004 in.) or less

Service Limit: TIR 0.2 mm (0.008 in.)

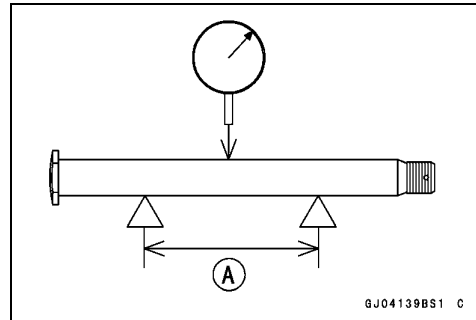

Tires

Tire Removal

CAUTION
<p>Do not lay the wheel on the ground with the disc facing down. This can damage or warp the disc. Place blocks under the wheel so the disc does not touch the ground.</p>

- Remove the wheel from the motorcycle (see Wheels Removal).
- To maintain front wheel balance, mark [A] the valve stem position on the tire with chalk so that the tire can be reinstalled in the same position.
- Remove the valve cap [B].
- Take out the valve core [A] to let out the air.
- Remove the valve stem nut [B].
- When handling the rim, be careful not to damage the rim flanges.

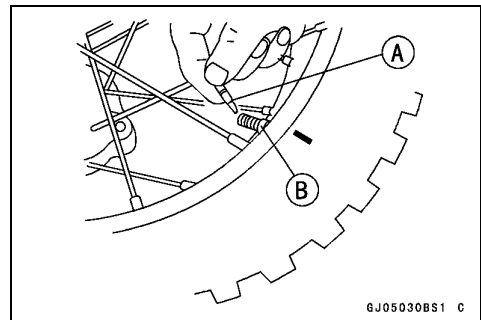
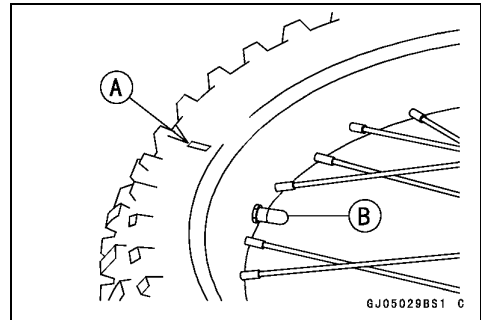

- Loosen the bead protector nut [A].
- Lubricate the tire beads and rim flanges on both sides with a soap and water solution or rubber lubricant. This helps the tire beads slip off the rim flanges.

CAUTION
<p>Never lubricate with mineral oil (engine oil) or gasoline because they will cause deterioration of the tire.</p>

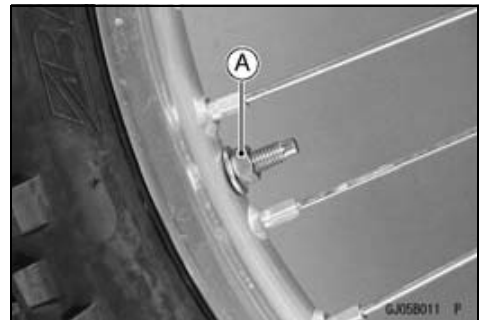

- Break the beads away from both sides of the rim with the bead breaker [A].

Special Tool - Bead Breaker Assembly: 57001-1072

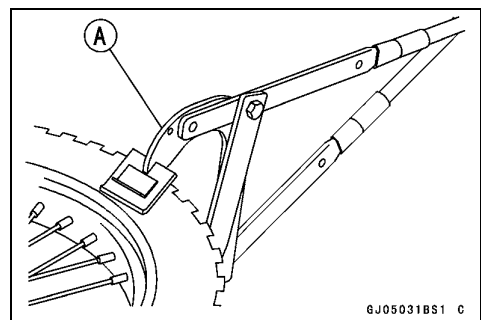

10-12 WHEELS/TIRES

Tires

- Step on the side of the tire opposite valve stem, pry the tire off the rim with the tire iron [A] of the bead breaker protecting the rim with rim protectors [B].

Special Tools - Rim Protector: 57001-1063

Bead Breaker Assembly: 57001-1072

CAUTION

Take care not to inset the tire irons so deeply that the tube gets damaged.

- Remove the bead protector and tube when one side of the tire is pried off.
- Pry the tire off the rim.

Tire Installation

NOTE

○ *The Tires should be installed so that the ID serial NO. [A] faces to left side.*

- Inspect the rim and tire, and replace them if necessary.
 - Install the tube band and tube.
 - Apply a soap and water solution, or rubber lubricant to the rim flange and tire beads.
-
- Position the front tire on the rim so that the valve [A] is at the tire balance mark [B] (the chalk mark made during removal, or the white paint mark on a new tire. see Removal).
 - Insert the valve stem into the rim, and screw the nut on loosely.
 - Fit the rim protectors and use tire irons to install the tire bead.

NOTE

○ *To prevent rim damage, be sure to place the rim protectors at any place the tire irons are applied.*

- Pry one side of the tire back onto the rim. Fit the bead protector into the tire.
- Pry the other side of the tire onto the rim, starting at the side opposite the valve.
- Take care not to insert the tire irons so deeply that the tube is damaged.
- Install the other side of the tire bead onto the rim in the same manner.
- Check that the tube is not pinched between the tire and rim.

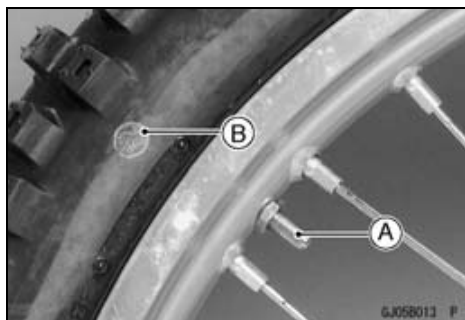
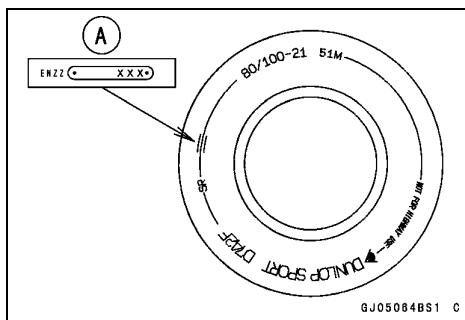
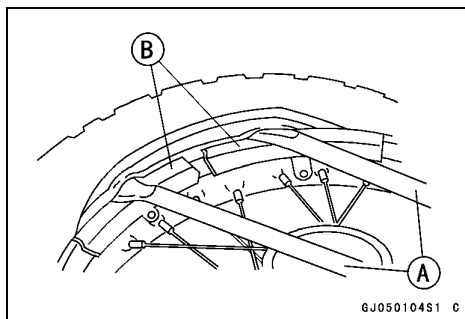

Tires

- Tighten the bead protector nut [A] and valve stem nut [B], and put on the valve cap [C].
- Check and adjust the air pressure after installing.

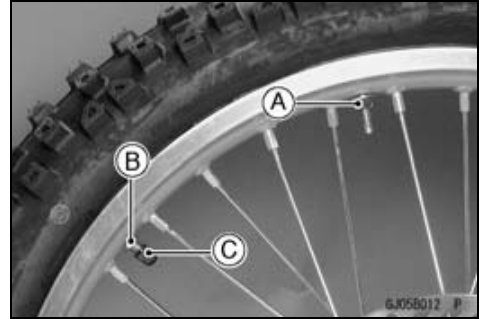
*Air Pressure Inspection/Adjustment*

- Refer to the Air Pressure Inspection/Adjustment in the Periodic Maintenance chapter.

10-14 WHEELS/TIRES

Hub Bearings

Hub Bearing Removal

- Remove the wheel (see Wheel Removal).

CAUTION

Do not lay the wheel on the ground with the disc facing down. This can damage or warp the disc. Place blocks under the wheel so that the disc does not touch the ground.

- Remove the oil seals and circlips.

Special Tool - Inside Circlip Pliers: 57001-143

- Remove the hub bearing by tapping evenly around the bearing inner race as shown.

[A] Bar

[B] Distance Collar

[C] Hub Bearing

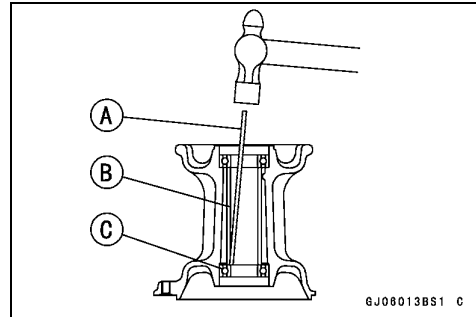

Hub Bearing Installation

- Before installing the wheel bearings, blow any dirt or foreign particles out of the hub [A] with compressed air to prevent contamination of the bearings.
- Replace the bearings with new ones.
- Lubricate them and install them using the bearing driver set [B] so that the marked or shielded sides face out.
- Press in the bearings until they are bottomed.

Special Tool - Bearing Driver Set: 57001-1129

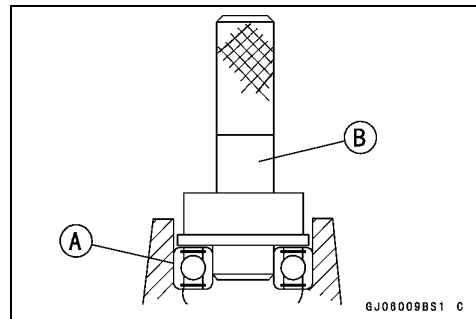

- Replace the circlips and oil seals with new ones.
- Press in the oil seals [A] so that the seal surface is flush [B] with the end of the hole.
- Apply high temperature grease to the oil seal lips.

Special Tool - Bearing Driver set: 57001-1129 [C]

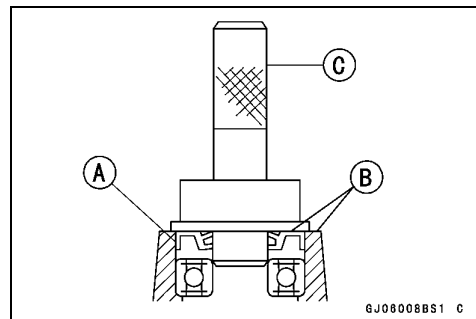

Hub Bearing Inspection

NOTE

○ It is not necessary to remove any bearings for inspection. If any bearings are removed, they will need to be replaced with new ones.

- Spin [A] it by hand to check its condition.
- ★ If it is noisy, does not spin smoothly, or has any rough spots, it must be replaced.
- Examine the bearing seal [B] for tears or leakage.
- ★ If the seal is torn or is leaking, replace the bearing.

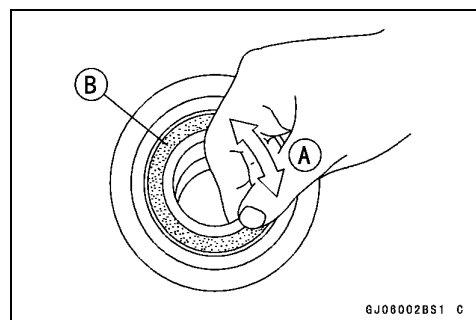

Final Drive

Table of Contents

Exploded View	11-2
Specifications	11-4
Drive Chain	11-5
Drive Chain Slack Inspection	11-5
Drive Chain Slack Adjustment	11-5
Wheel Alignment Inspection	11-5
Wheel Alignment Adjustment	11-5
Drive Chain Wear Inspection	11-5
Drive Chain Lubrication	11-5
Drive Chain Removal	11-5
Drive Chain Installation	11-5
Sprockets	11-7
Engine Sprocket Removal	11-7
Engine Sprocket Installation	11-7
Rear Sprocket Removal	11-7
Rear Sprocket Installation	11-8
Sprocket Wear Inspection	11-8
Rear Sprocket Warp Inspection	11-8

11-2 FINAL DRIVE

Exploded View

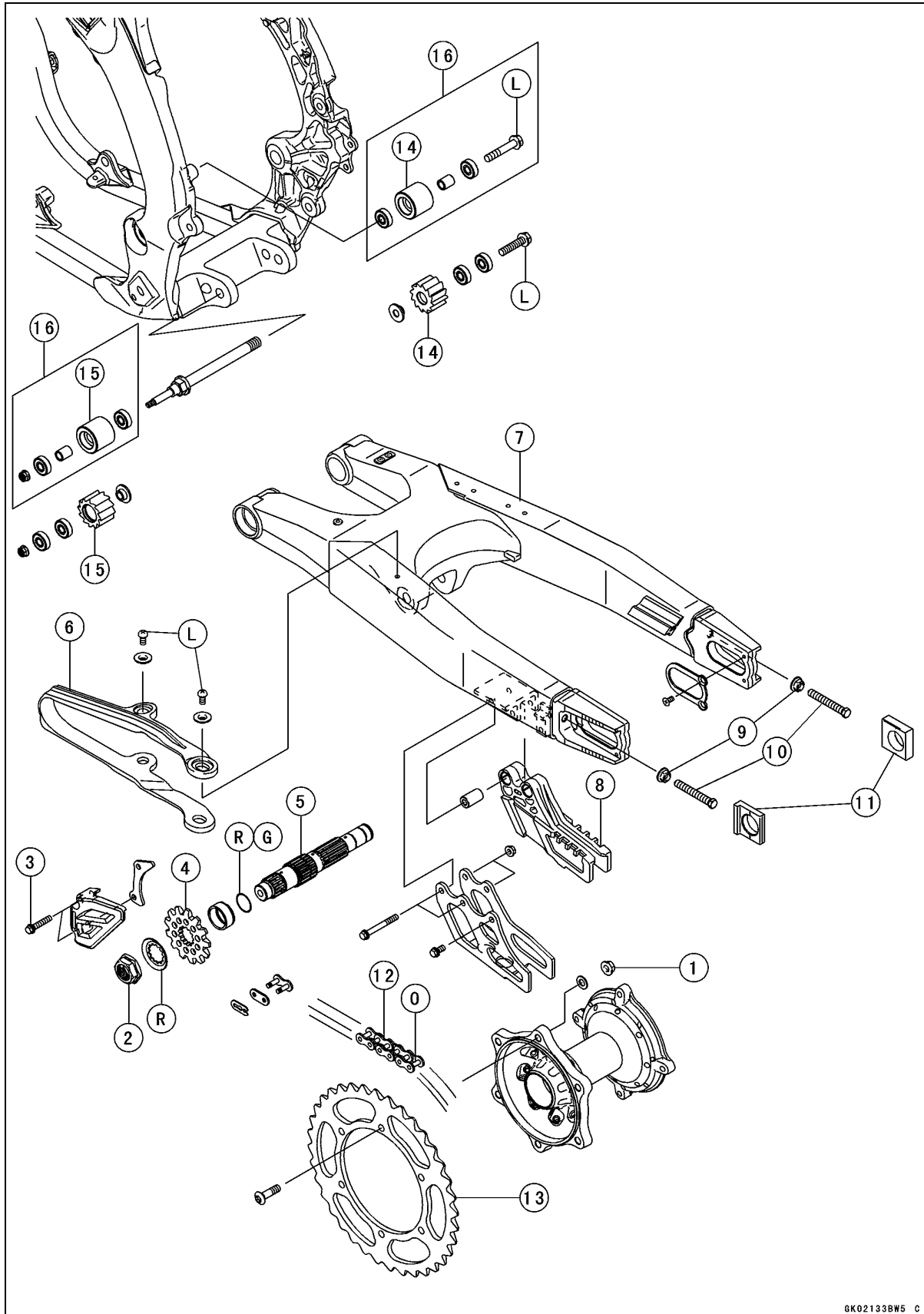

GK02133BWS C

Exploded View

No	Fastener	Torque			Remarks
		N·m	kgf·m	ft·lb	
1	Rear Sprocket Nuts	34	3.5	25	
2	Engine Sprocket Nut	127	13	94	
3	Engine Sprocket Cover Bolts	9.8	1.0	87 in·lb	

- 4. Engine Sprocket
- 5. Output Shaft
- 6. Chain Slipper
- 7. Swingarm
- 8. Chain Guide
- 9. Locknut
- 10. Adjusting Bolt
- 11. Chain Adjuster
- 12. Drive Chain
- 13. Rear Sprocket
- 14. Upper Chain Guide Roller
- 15. Lower Chain Guide Roller
- 16. KX450D6F
- G: Apply grease.
- L: Apply a non-permanent locking agent.
- O: Apply oil.
- R: Replacement Parts

11-4 FINAL DRIVE

Specifications

Item	Standard	Service Limit
Drive Chain		
Chain Slack	52 ~ 58 mm (2.0 ~ 2.3 in.)	---
Chain 20-link Length	317.5 ~ 318.2 mm (12.50 ~ 12.53 in.)	323 mm (12.7 in.)
Standard Chain:		
Make	DAIDO	---
Type	D.I.D 520DMA2	---
Length	114 Links	---
Sprocket		
Rear Sprocket Warp	Under 0.4 mm (0.016 in.)	0.5 mm (0.020 in.)

Drive Chain

Drive Chain Slack Inspection

- Refer to the Drive Chain Slack Inspection in the Periodic Maintenance chapter.

Drive Chain Slack Adjustment

- Refer to the Drive Chain Slack Adjustment in the Periodic Maintenance chapter.

Wheel Alignment Inspection

- Check that the rear end [A] of the left chain adjuster aligns with the same swing arm mark [B] as the right chain adjuster.

⚠ WARNING

Misalignment of the wheel will result in abnormal wear, and may result in an unsafe riding condition.

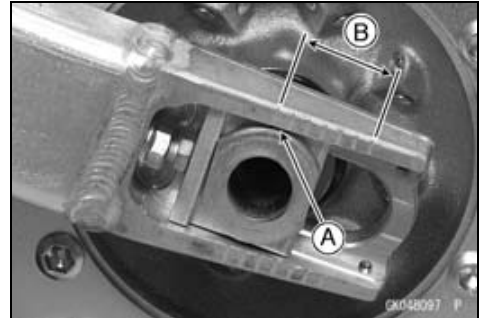

Wheel Alignment Adjustment

This procedure is the same as Drive Chain Slack Adjustment (see Drive Chain Slack Adjustment in the Periodic Maintenance chapter).

Drive Chain Wear Inspection

- Refer to the Drive Chain Wear Inspection in the Periodic Maintenance chapter.

Drive Chain Lubrication

- Refer to the Drive Chain Lubrication in the Periodic Maintenance chapter.

Drive Chain Removal

- Remove the engine sprocket cover (see Engine Sprocket Removal).
- Remove the clip [A] from the master link using pliers, and free the drive chain from the rear sprocket.
- Remove the drive chain from the chassis.

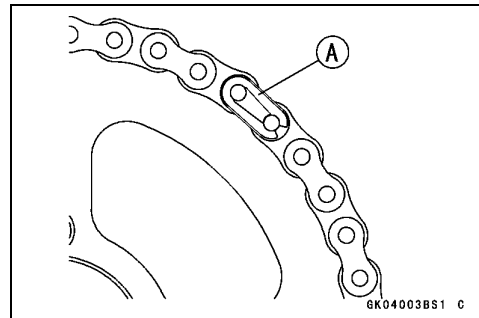

Drive Chain Installation

- Fit the drive chain back onto the sprockets with the ends at the rear sprocket.
- Install the master link [A] from the frame side.
- Install the link plate [B] so that the mark faces out.
Clip [C]

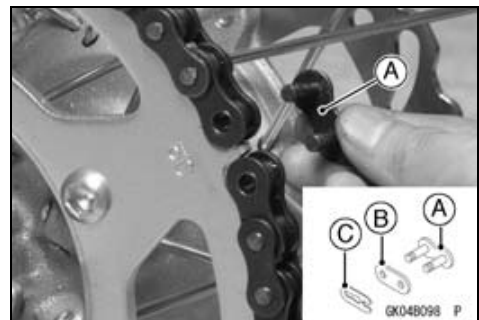

11-6 FINAL DRIVE

Drive Chain

- Install the clip [A] so that the closed end [B] of the "U" pointed in the direction of chain rotation [C].
- Adjust the drive chain slack (see Drive Chain Slack Adjustment).
- Check the rear brake.

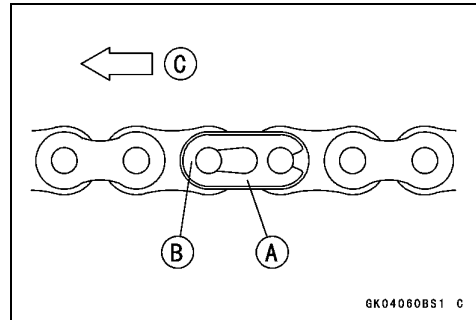

Sprockets

Engine Sprocket Removal

- Remove:
 - Engine Sprocket Cover Bolts [A]
 - Engine Sprocket Cover [B]
 - Drive Chain Guide [C]

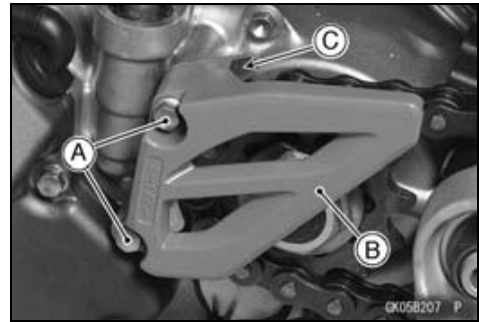

- Remove:
 - Drive Chain [B] (free of engine sprocket)
- Flatten the bended sprocket washer [A].
- Remove the engine sprocket nut [C] and sprocket washer, and pull off the engine sprocket [D].

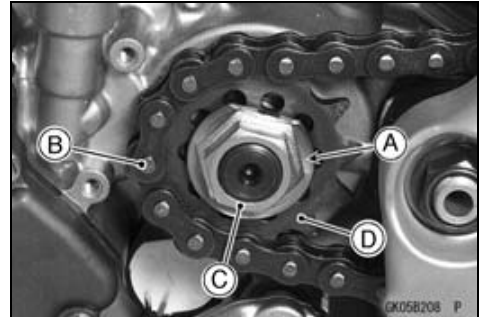

Engine Sprocket Installation

- Install the engine sprocket so that the flatten side faces [A] inside.
- Replace the sprocket washer with a new one.
- Install the sprocket washer and sprocket nut.

Torque - Engine Sprocket Nut: 127 N·m (13 kgf·m, 94 ft·lb)

- Bend the one side of the sprocket washer on the nut.
- Install the engine sprocket cover.

Torque - Engine Sprocket Cover Bolts : 9.8 N·m (1.0 kgf·m, 87 in·lb)

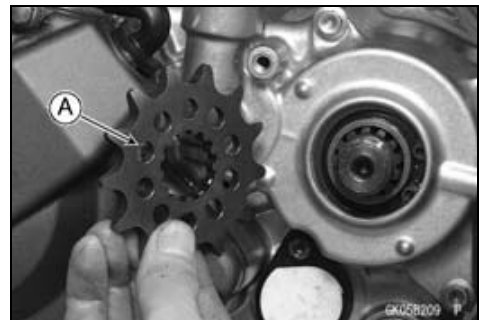

Rear Sprocket Removal

- Remove the rear wheel (see Rear wheel Removal in the Wheels/Tires chapter).

CAUTION

Do not lay the wheel on the ground with the disc facing down. This can damage or warp the disc. Place blocks under the wheel so that the disc does not touch the ground.

- Unscrew the rear sprocket bolts [A], and remove the rear sprocket [B].

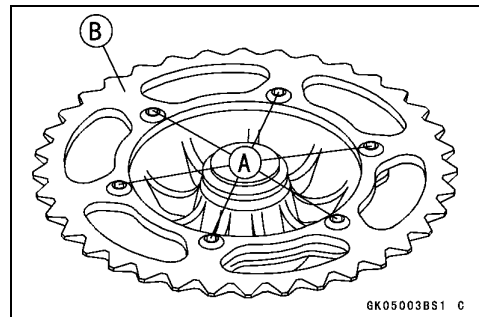

11-8 FINAL DRIVE

Sprockets

Rear Sprocket Installation

- Install the rear sprocket [A] so that the marked side [B] faces out.
- Install the rear sprocket bolts and tighten the nuts.

Torque - Rear Sprocket Nuts: 34 N·m (3.5 kgf·m, 25 ft·lb)

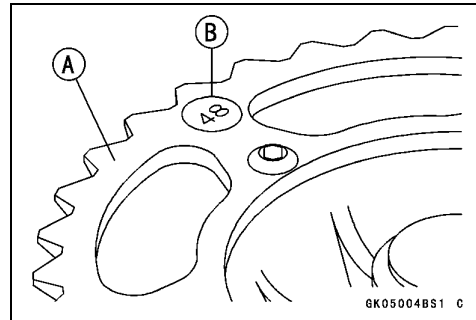

Sprocket Wear Inspection

- Refer to the Sprocket Wear Inspection in the Periodic Maintenance chapter.

Rear Sprocket Warp Inspection

- Refer to the Rear Sprocket Warp Inspection in the Periodic Maintenance chapter.

Brakes

Table of Contents

Exploded View	12-2
Specifications	12-6
Special Tools	12-7
Brake Lever, Brake Pedal	12-8
Brake Lever Adjustment	12-8
Brake Pedal Position Adjustment	12-8
Brake Pedal Removal	12-8
Brake Pedal Installation	12-8
Brake Fluid	12-9
Fluid Level Inspection	12-9
Fluid Change	12-9
Bleeding the Brake Line	12-10
Caliper	12-12
Caliper Removal	12-12
Caliper Installation	12-13
Caliper Disassembly	12-13
Fluid Seal Damage Inspection	12-13
Dust Seal and Cover Damage Inspection	12-13
Piston Cylinder Damage Inspection	12-13
Caliper Holder Shaft Wear Inspection	12-14
Brake Pad	12-15
Brake Pad Removal	12-15
Brake Pad Installation	12-15
Brake Pad Inspection	12-15
Master Cylinder	12-16
Front Master Cylinder Removal	12-16
Front Master Cylinder Installation	12-16
Rear Master Cylinder Removal	12-17
Rear Master Cylinder Installation	12-17
Front Master Cylinder Disassembly	12-17
Rear Master Cylinder Disassembly	12-17
Master Cylinder Assembly	12-17
Master Cylinder Inspection (Visual Inspection)	12-18
Brake Disk	12-19
Brake Disc Inspection	12-19
Brake Hose	12-20
Brake Hose Removal/Installation	12-20
Brake Hose Inspection	12-20

12-2 BRAKES

Exploded View

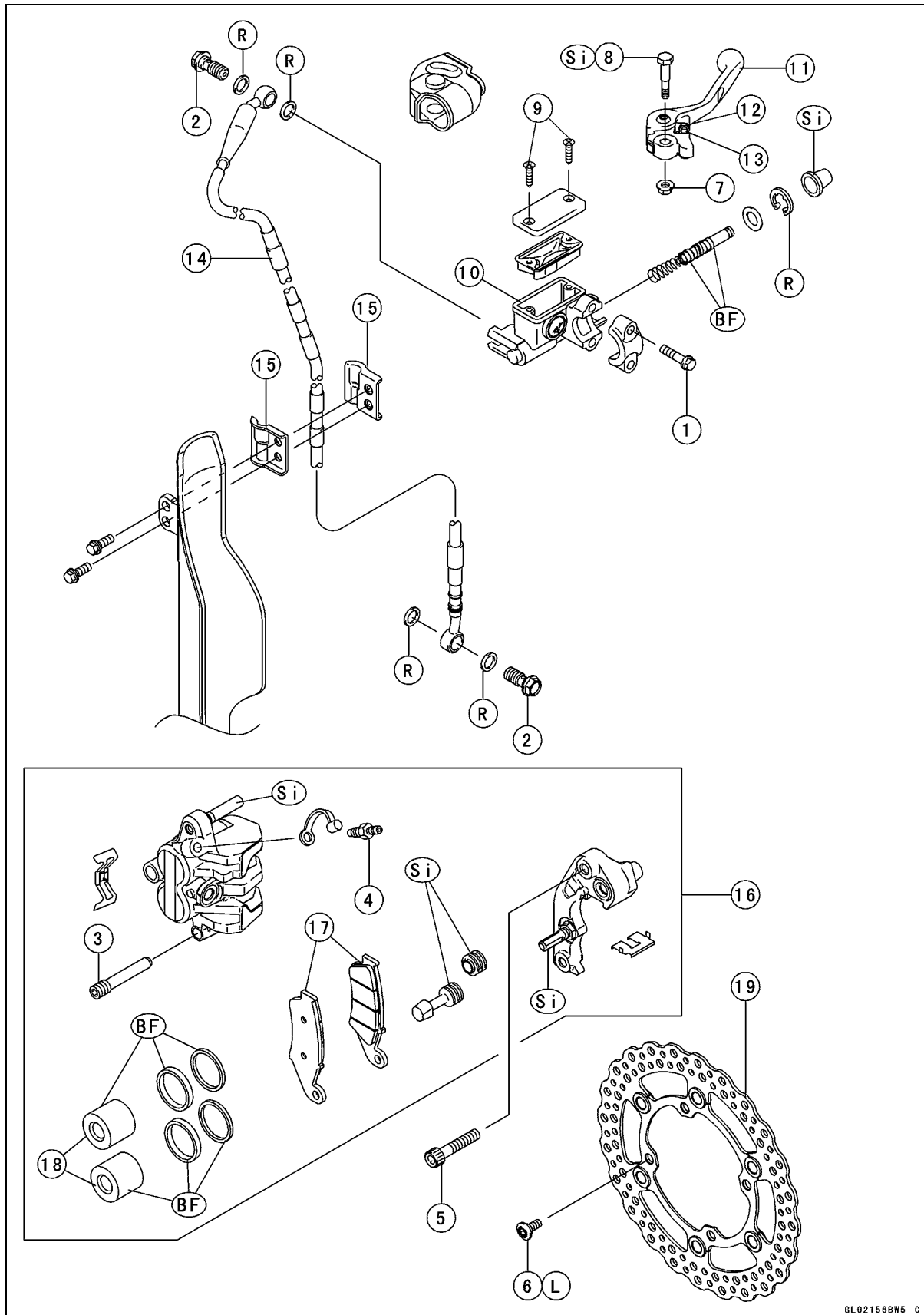

GL02156BWS C

Exploded View

No.	Fastener	Torque			Remarks
		N·m	kgf·m	ft·lb	
1	Front Master Cylinder Clamp Bolts	8.8	0.90	78 in·lb	S
2	Brake Hose Banjo Bolts	25	2.5	18	
3	Brake Pad Bolt	17	1.7	13	
4	Caliper Bleed Valve	7.8	0.80	69 in·lb	
5	Caliper Mounting Bolts (Front)	25	2.5	18	
6	Brake Disc Mounting Bolts (Front)	9.8	1.0	87 in·lb	L
7	Brake Lever Pivot Bolt Locknut	5.9	0.60	52 in·lb	
8	Brake Lever Pivot Bolt	5.9	0.60	52 in·lb	
9	Brake Reservoir Cap Screws (Front)	1.5	0.15	13 in·lb	

10. Front Brake Reservoir

11. Brake Lever

12. Brake Lever Adjuster

13. Locknut

14. Brake Hose

15. Clamps

16. Front Caliper

17. Brake Pad

18. Piston

19. Front Disc

BF: Apply brake fluid.

L: Apply a non-permanent locking agent.

R: Replacement Parts.

Si: Apply Silicone grease.

Exploded View

No.	Fastener	Torque			Re- marks
		N·m	kgf·m	ft·lb	
1	Brake Hose Banjo Bolts	25	2.5	18	
2	Rear Master Cylinder Mounting Bolts	9.8	1.0	87 in·lb	
3	Rear Master Cylinder Push Rod Locknut	17	1.7	13	
4	Caliper Bleed Valve	7.8	0.80	69 in·lb	
5	Brake Pad Bolt	17	1.7	13	
6	Rear Brake Pad Bolt Plug	2.5	0.25	22 in·lb	
7	Caliper Holder Shaft (Rear)	27	2.8	20	
8	Brake Pedal Mounting Bolt	25	2.5	18	L,G
9	Brake Disc Mounting Bolts (Rear)	23	2.3	17	L
10	Brake Reservoir Cap Bolts (Rear)	1.5	0.15	13 in·lb	

11. Brake Hose

12. Rear Master Cylinder

13. Brake Pedal

14. Rear Caliper Cover

15. Rear Caliper

16. Piston

17. Brake Pads

18. Rear Disc

BF: Apply brake fluid.

G: Apply high temperature grease.

L: Apply a non-permanent locking agent.

R: Replacement Parts

Si: Apply Silicone grease.

12-6 BRAKES

Specifications

Item	Standard	Service Limit
Brake adjustment Lever Play	Adjustable (to suit rider)	---
Brake Fluid Recommended Disc Brake Fluid: Type Front Rear	DOT3 or DOT4 DOT4	--- ---
Brake Pads Lining thickness: Front Rear	3.8 mm (0.15 in.) 6.4 mm (0.25 in.)	1 mm (0.04 in.) 1 mm (0.04 in.)
Brake Disc Thickness: Front Rear Runout	2.85 ~ 3.15 mm (0.112 ~ 0.124 in.) 3.85 ~ 4.15 mm (0.152 ~ 0.163 in.) TIR 0.25 mm (0.0098 in.) or less	2.5 mm (0.10 in.) 3.5 mm (0.14 in.) TIR 0.3 mm (0.01 in.)

Special Tools

Inside Circlip Pliers:
57001-143

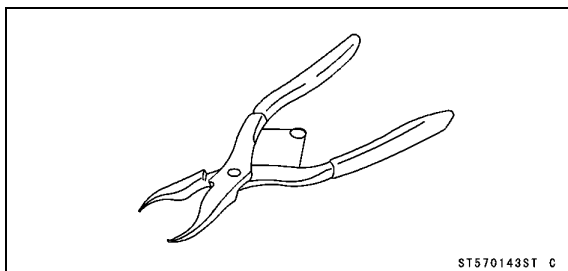

Jack:
57001-1238

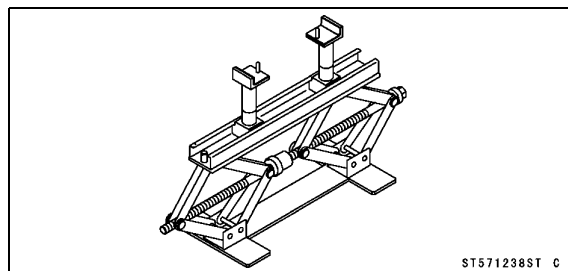

12-8 BRAKES

Brake Lever, Brake Pedal

Brake Lever Adjustment

- Refer to the Brake Lever and Pedal Position Adjustment in the Periodic Maintenance chapter.

Brake Pedal Position Adjustment

- Refer to the Brake Lever and Pedal Position Adjustment in the Periodic Maintenance chapter.

Brake Pedal Removal

- Remove:
 - Cotter Pin [A]
 - Joint Pin [B]
 - Washer [C]
- Remove the mounting bolt [D] and take off the brake pedal [E] and return spring.

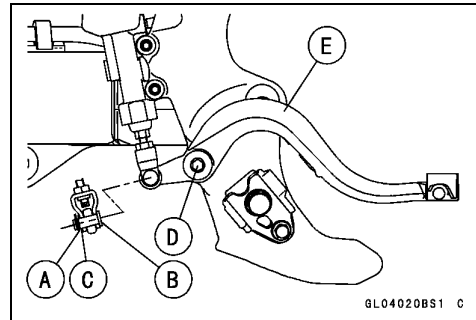

Brake Pedal Installation

- Replace the O-rings with new one and apply high temperature grease to the O-rings.
- Apply high temperature grease to the shaft portion and a non-permanent locking agent to the thread of the brake pedal mounting bolt, and install the pedal with return spring onto the frame.
- Install the return spring direction [A] as shown.

Torque - Brake Pedal Mounting Bolt: 25 N·m (2.5 kgf·m, 18 ft·lb)

- Check the brake pedal position.
- Install the joint pin, washer and a new cotter pin.
- Bend the ends [A] of the cotter pin.

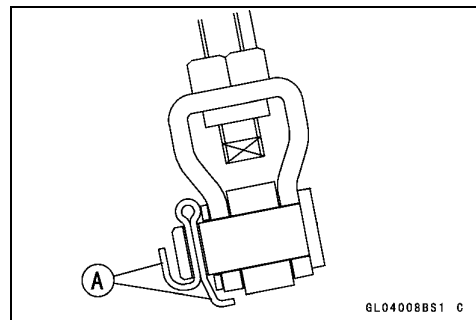
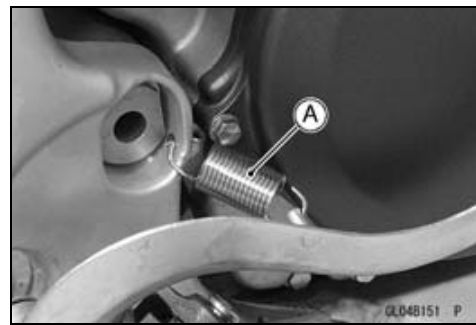

Brake Fluid

WARNING

When working with the disc brake, observe the precautions listed below.

1. Never reuse old brake fluid.
2. Do not use fluid from a container that has been left unsealed or that has been open for a long time.
3. Do not mix two types and brands of fluid for use in the brake. This lowers the brake fluid boiling point and could cause the brake to be ineffective. It may also cause the rubber brake parts to deteriorate.
4. Don't leave the reservoir cap off for any length of time to avoid moisture contamination of the fluid.
5. Don't change the fluid in the rain or when a strong wind is blowing.
6. Except for the disc pads and disc, use only disc brake fluid, isopropyl alcohol, or ethyl alcohol for cleaning of the brake parts. Do not use any other fluid for cleaning these parts. Gasoline, engine oil, or any other petroleum distillate will cause deterioration of the rubber parts. Oil spilled on any part will be difficult to wash off completely and will eventually deteriorate the rubber used in the disc brake.
7. When handling the disc pads or disc, be careful that no disc brake fluid or any oil gets on them. Clean off any fluid or oil that inadvertently gets on the pads or disc with a high-flash point solvent. Do not use one which will leave an oily residue. Replace the pads with new ones if they cannot be cleaned satisfactorily.
8. Brake fluid quickly ruins painted surfaces; any spilled fluid should be completely wiped up immediately.
9. If any of the brake line fittings or the bleed valve is opened at any time, the **AIR MUST BE BLED FROM THE BRAKE LINE.**

Fluid Level Inspection

- Refer to the Brake Fluid Level Inspection in the Periodic Maintenance chapter.

Fluid Change

- Refer to the Brake Fluid Change in the Periodic Maintenance chapter.

12-10 BRAKES

Brake Fluid

Bleeding the Brake Line

The brake fluid has a very low compression coefficient so that almost all the movement of the brake lever or pedal is transmitted directly to the caliper for braking action. Air, however, is easily compressed. When air enters the brake lines, brake lever or pedal movement will be partially used in compressing the air. This will make the lever or pedal feel spongy, and there will be a loss in braking power.

▲ WARNING

Be sure to bleed the air from the brake whenever brake lever or pedal action feels soft or spongy, after the brake fluid is changed, or whenever a brake line fitting has been loosened for any reason.

NOTE

○ *The procedure to bleed the front brake line is as follows. Bleeding the rear brake line is the same as for the front brake.*

- Remove the reservoir cap, and check that there is plenty of fluid in the reservoir.
- With the reservoir cap off, slowly pump the brake lever several times until no air bubbles can be seen rising up through the fluid from the holes at the bottom of the reservoir.
- Bleed the air completely from the master cylinder by this operation.
- Install the reservoir cap.
- Attach a clear plastic hose to the bleed valve on the caliper, and run the other end of the hose into a container.
- Bleed the brake line and the caliper as follows:
 - Repeat this operation until no more air can be seen coming out into the plastic hose.
 1. Pump the brake lever until it becomes hard, and apply the brake and hold it [A].
 2. Quickly open and close the bleed valve while holding the brake applied [B].
 3. Release the brake [C].

NOTE

○ *The fluid level must be checked often during the bleeding operation and replenished with fresh brake fluid as necessary. If the fluid in the reservoir runs almost out any time during bleeding operation, the bleeding operation must be done over again from the beginning since air will have entered the line.*

○ *Tap the brake hose lightly from the caliper to the reservoir for easier bleeding.*

- Remove the clear plastic hose.
- Tighten the bleed valves, and install the rubber caps.

Torque - Caliper Bleed Valve: 7.8 N·m (0.80 kgf·m, 69 in·lb)

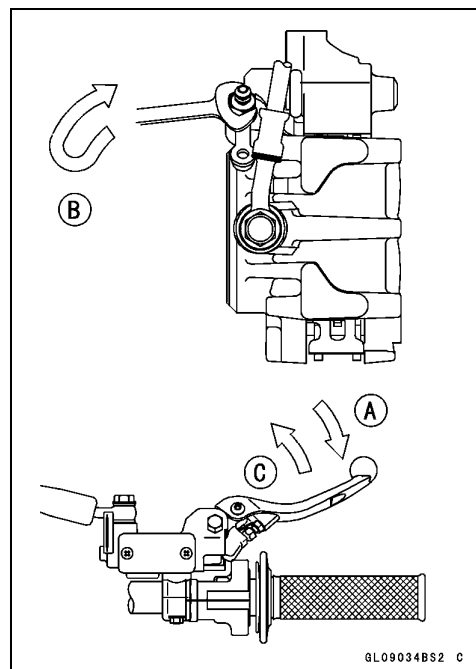

Brake Fluid

- Check the fluid level.
- After bleeding is done, check the brake for good braking power, no brake drag, and no fluid leakage.

⚠ WARNING

Do not attempt to drive the motorcycle until a full brake lever or pedal is obtained by pumping the brake lever or pedal until the pads are against the disc. The brake will not function on the first application of the lever or pedal if this is not done.

12-12 BRAKES

Caliper

Caliper Removal

Front Brake:

- Loosen the banjo bolt [A] so as not to spill brake fluid.
- Remove the caliper mounting bolts [B].
- Remove the banjo bolt and take off the brake hose from the caliper [C].
- If the caliper is to be disassembled after removal and if compressed air is not available, remove the piston using the following steps before disconnecting the brake hose from the caliper.
 - Remove the pads.
 - Pump the brake lever to remove the piston.

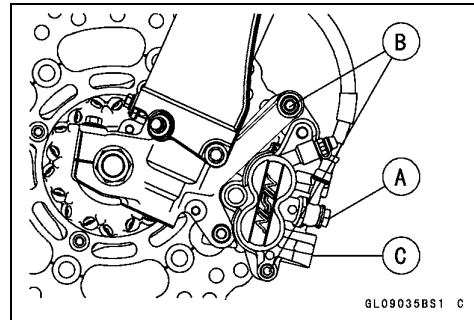

Rear Brake:

- Unbolt the caliper guard bolts [A] and remove the caliper guard [B].
- Unbolt the disc guard bolts [C] and remove the disc guard [D].

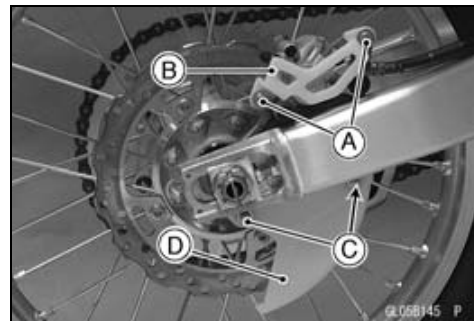

- Loosen the banjo bolt [A] so as not to spill brake fluid.
- Loosen the brake pad bolt plug [B], and pad bolt [C] before the caliper removal if the caliper is to be disassembled.

NOTE

○ If the caliper is to be disassembled after removal and compressed air is not available, disassemble the caliper before brake hose removal (see *Caliper Disassembly*).

- Remove the rear wheel. (see *Rear Wheel Removal* in the *Wheels/Tires* chapter)
- Unscrew the banjo bolt and remove the brake hose [D] from the caliper (see *Brake Hose Replacement* in the *Periodic Maintenance* chapter).

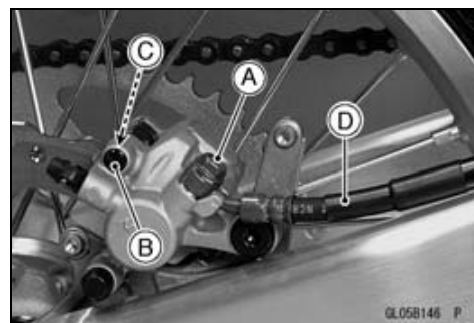

CAUTION

Immediately wipe up any brake fluid that is spilled.

Caliper

Caliper Installation

- Tighten the brake pad bolts if it was removed.

Torque - Brake Pad Bolts: 17 N·m (1.7 kgf·m, 13 ft·lb)

Front Brake:

- Install the caliper and tighten the bolts.

Torque - Caliper Mounting Bolts (Front): 25 N·m (2.5 kgf·m, 18 ft·lb)

Rear Brake:

- Before install the caliper, install the rear wheel (see Rear Wheel Installation in the Wheels/Tires chapter).
- Install the caliper.

Torque - Caliper Holder Shaft (Rear): 27 N·m (2.8 kgf·m, 20 ft·lb)

- Install the brake hose lower end.
- Replace the washers that are on each side of hose fitting with new ones.

Torque - Brake Hose Banjo Bolt: 25 N·m (2.5 kgf·m, 18 ft·lb)

- Bleed the brake line (see Bleeding the Brake Line).
- Check the brake for good braking power, no brake drag, and no fluid leakage.

⚠ WARNING

Do not attempt to drive the motorcycle until a full brake lever or pedal is obtained by pumping the brake lever or pedal until the pads are against the disc. The brakes will not function on the first application of the lever or pedal if this is not done.

Caliper Disassembly

- Refer to the Caliper Piston Seal and Dust Seal Replacement in the Periodic Maintenance chapter.

Fluid Seal Damage Inspection

The fluid seal around the piston maintains the proper pad/disc clearance. If this seal is not in good condition, pad wear will increase, and constant pad drag on the disc will raise brake and brake fluid temperature.

- Replace the fluid seals under any of the following conditions: (a) fluid leakage around the pad; (b) brakes overheat; (c) there is a large difference in left and right pad wear; (d) the seal is stuck to the piston. If the fluid seal is replaced, replace the dust seal as well. Also, replace all seals every other time the pads are changed.

Dust Seal and Cover Damage Inspection

- Check that the dust seals and covers are not cracked, worn, swollen, or otherwise damaged.
- ★ If they show any damage, replace them.

Piston Cylinder Damage Inspection

- Visually inspect the piston and cylinder surfaces.
- ★ Replace the cylinder and piston if they are badly scored or rusty.

12-14 BRAKES

Caliper

Caliper Holder Shaft Wear Inspection

The caliper body must slide smoothly on the caliper holder shafts. If the body does not slide smoothly, one pad will wear more than the other, pad wear will increase, and constant drag on the disc will raise brake and brake fluid temperature.

- Check to see if the caliper holder shafts are not badly worn or stepped, or the rubber boot is not damaged.
- ★ If the shafts or rubber boot are damaged, replace the shafts, rubber boot, and the caliper holder.

Brake Pad

Brake Pad Removal

For Front Brake Pad

- Unscrew the pad bolt [A].
- Take the piston side pad [B].
- Push the caliper holder toward the piston, and then remove another pad [C] from the caliper holder.

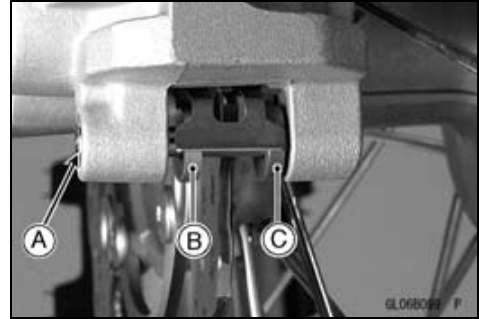

For Rear Brake Pad

- Remove:
Plug [A]

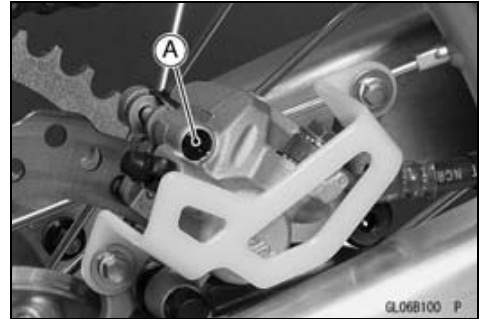

- Unscrew the pad bolt [A].
- Take the piston side pad [B].
- Push the caliper hold toward the piston, and then remove another pad [C] from the caliper holder.

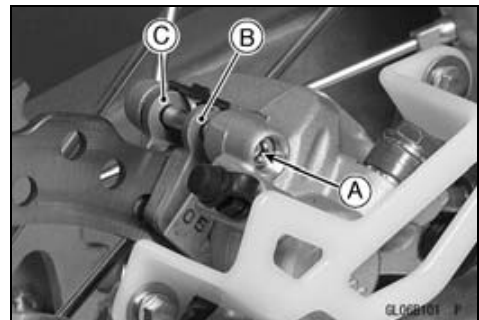

Brake Pad Installation

- Push the caliper pistons in by hand as far as they will go.
- Install the piston side pad first, and then another pad.
- Fit the pad end [A] into the groove [B] of the anti-rattle spring securely.
- Tighten the brake pad bolt.

Torque - Brake Pad Bolt: 17 N·m (1.7 kgf·m, 13 ft·lb)

Rear Brake Pad Bolt Plug: 2.5 N·m (0.25 kgf·m, 22 in·lb)

- Check the brake for good braking power, no brake drag, and no fluid leakage.

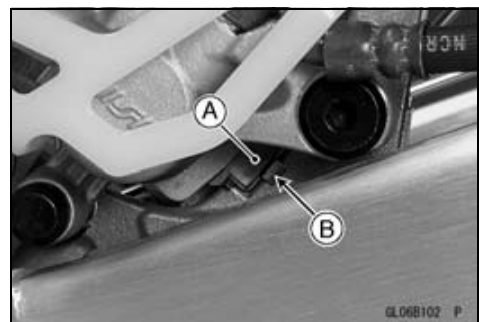

⚠ WARNING

Do not attempt to drive the motorcycle until a full brake lever or pedal is obtained by pumping the brake lever or pedal until the pads are against the disc. The brake will not function on the first application of the lever or pedal if this is not done.

Brake Pad Inspection

- Refer to the Brake Pad Wear Inspection in the Periodic Maintenance chapter.

12-16 BRAKES

Master Cylinder

CAUTION

Brake fluid quickly ruins painted or plastic surfaces; any spilled fluid should be completely wiped up immediately.

Front Master Cylinder Removal

- Remove the banjo bolt [A] to disconnect the upper brake hose [B] from the master cylinder [C].
- When removing the brake hose, temporarily secure the end of the brake hose to some high place to keep fluid loss to a minimum.

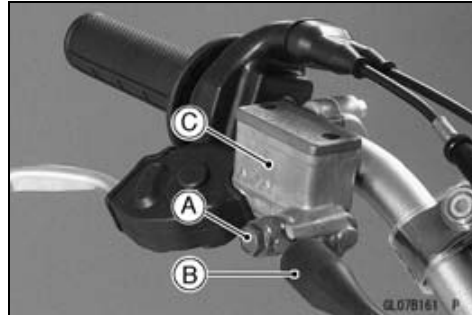

- Unscrew the clamp bolts [A], and take off the master cylinder [B] as an assembly with the reservoir and brake lever.

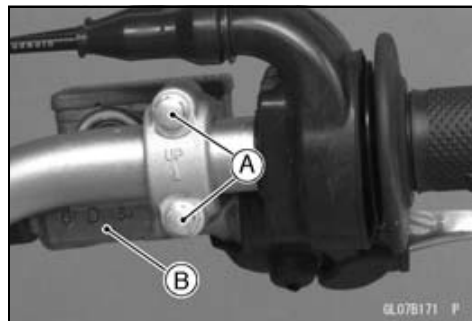

Front Master Cylinder Installation

- Install the master cylinder so that the reservoir cap [B] is horizontally and position it from edge of the grip to 185 mm (7.28 in.) [A].

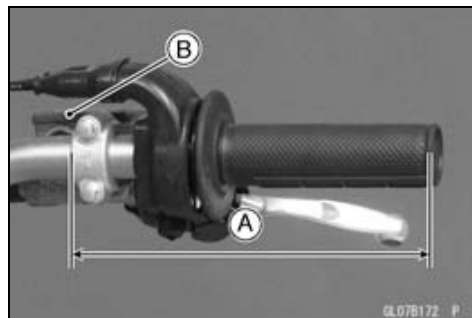

- The master cylinder clamp must be installed with the arrow mark [A] upward.
- Tighten the upper clamp bolt [B] first, and then the lower clamp bolt [C]. There will be a gap at the lower part of the clamp after tightening.

Torque - Master Cylinder Clamp Bolts: 8.8 N·m (0.90 kgf·m, 78 in·lb)

- Replace the washers that are on each side of hose fitting with new ones.
- Tighten the brake hose banjo bolt.

Torque - Brake Hose Banjo Bolt: 25 N·m (2.5 kgf·m, 18 ft·lb)

- Bleed the brake line (see Bleeding the Brake Line).
- Check the brake for good braking power, no brake drag, and no fluid leakage.

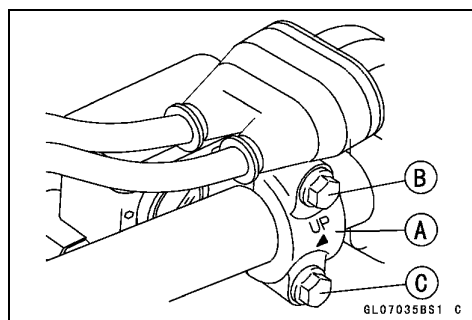

Master Cylinder

Rear Master Cylinder Removal

- Remove the cotter pin [A].
- Pull off the joint pin [B] with washer.

NOTE

○ Pull off the joint pin while pressing down the brake pedal.

- Unscrew the master cylinder mounting bolts [C], and remove the master cylinder [D].
- Unscrew the brake hose banjo bolt [E].
- When removing the brake hose, temporarily secure the end of the brake hose to some high place to keep fluid loss to a minimum.

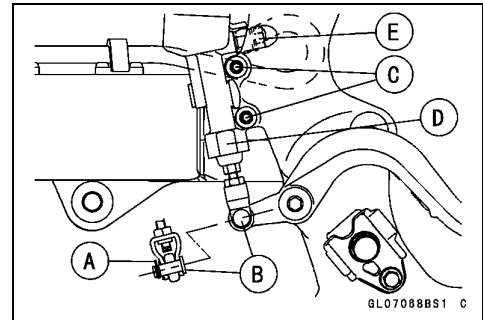

Rear Master Cylinder Installation

- Replace the cotter pin with a new one.
- Replace the washers are on each side of hose fitting with new ones.
- Tighten the following:

Torque - Brake Hose Banjo Bolt: 25 N·m (2.5 kgf·m, 18 ft·lb)

Rear Master Cylinder Mounting Bolts: 9.8 N·m (1.0 kgf·m, 87 in·lb)

Rear Master Cylinder Push Rod Locknut: 17 N·m (1.7 kgf·m, 13 ft·lb)

- Bleed the brake line (see Bleeding the Brake Line).
- Check the brake for good braking power, no brake drag, and no fluid leakage.
- Check the brake pedal position (see Brake Lever and Pedal Position Adjustment in the Periodic Maintenance chapter).

Front Master Cylinder Disassembly

- Refer to the Brake Master Cylinder Cup and Dust Cover Replacement in the Periodic Maintenance chapter.

Rear Master Cylinder Disassembly

- Refer to the Brake Master Cylinder Cup and Dust Cover Replacement in the Periodic Maintenance chapter.

Master Cylinder Assembly

- Refer to the Brake Master Cylinder Cup and Dust Cover Replacement in the Periodic Maintenance chapter.

12-18 BRAKES

Master Cylinder

Master Cylinder Inspection (Visual Inspection)

- Disassemble the front and rear master cylinders.
 - Check that there are no scratches, rust or pitting on the inner wall of each master cylinder [A] and on the outside of each piston [B].
 - ★ If a master cylinder or piston shows any damage, replace them.
 - Inspect the primary [C] and secondary [D] cups.
 - ★ If a cup is worn, damaged, softened (rotted), or swollen, the piston assembly should be replaced to renew the cups.
 - ★ If fluid leakage is noted at the brake lever, the piston assembly should be replaced to renew the cup.
 - Check the dust covers [E] for damage.
 - ★ If they are damaged, replace them.
 - Check that the relief [F] and supply [G] ports are not plugged.
 - ★ If the small relief port becomes plugged, the brake pads will drag on the disc. Blow the ports clean with compressed air.
 - Check the piston return springs [H] for any damage.
 - ★ If a spring is damaged, replace it.
- [J] Front Master Cylinder
[K] Rear Master Cylinder

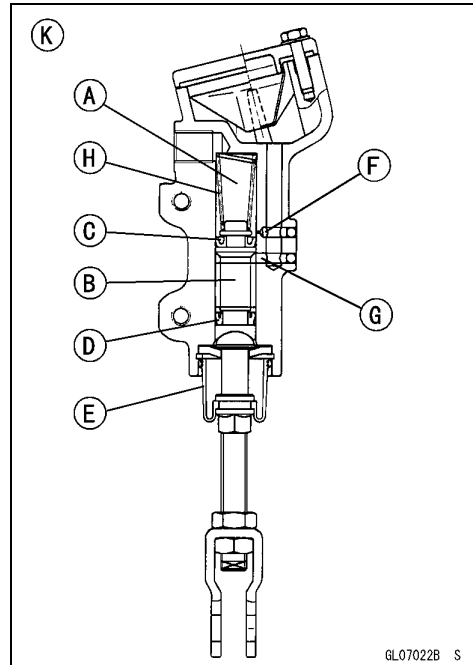
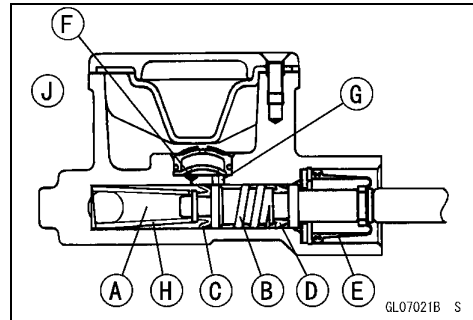

Brake Disk

Brake Disc Inspection

- Visually inspect the disc [A].
- ★ If it is scratched or damaged, replace the disc.
- Measure the thickness of each disc at the point [B] where it has worn the most.
- ★ Replace the disc if it has worn past the service limit.

Thickness

Standard:

Front 2.85 ~ 3.15 mm (0.112 ~ 0.124 in.)

Rear 3.85 ~ 4.15 mm (0.152 ~ 0.163 in.)

Service Limit:

Front 2.5 mm (0.10 in.)

Rear 3.5 mm (0.14 in.)

Torque - Brake Disc Mounting Bolts (Front): 9.8 N·m (1.0 kgf·m, 87 in·lb)

Brake Disc Mounting Bolts (Rear): 23 N·m (2.3 kgf·m, 17 ft·lb)

- Place a jack under the motorcycle so that the front/rear wheel is raised off the ground.

Special Tool - Jack: 57001-1238

- Set up a dial gauge against the disc [A] as illustrated.
- For the front disc, turn the handlebar fully to one side.
- Measure the disc runout while rotating the wheel slowly [B].
- ★ If the runout exceeds the service limit, replace the disc.

Runout

Standard: TIR 0.25 mm (0.098 in.) or less

Service Limit: TIR 0.3 mm (0.01 in.)

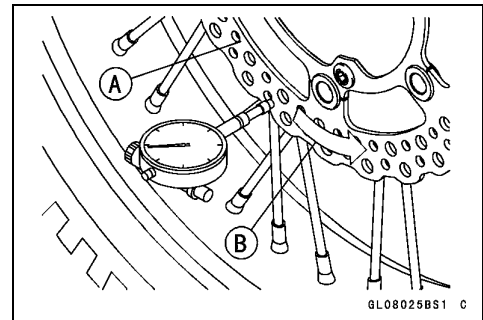
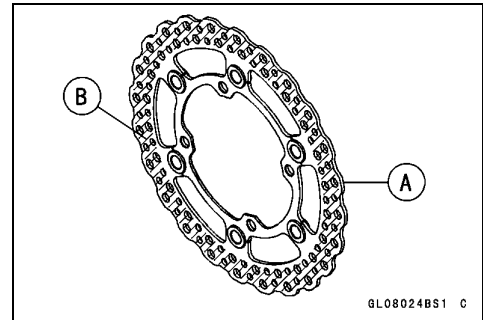

12-20 BRAKES

Brake Hose

Brake Hose Removal/Installation

- Refer to the Brake Hose Replacement in the Periodic Maintenance chapter.

Brake Hose Inspection

- Refer to the Brake Hoses and Connections Inspection in the Periodic Maintenance chapter.

Suspension

Table of Contents

Exploded View	13-2	Rear Shock Absorber	13-41
Specifications	13-8	Rebound Damping Adjustment....	13-41
Special Tools	13-10	Compression Damping	
Front Fork (KX450D6F ~ D7F)	13-11	Adjustment	13-41
Air Pressure	13-11	Spring Preload Adjustment	13-42
Rebound Damping Adjustment....	13-11	Spring Tension Inspection.....	13-43
Compression Damping		Rear Shock Absorber Removal ...	13-44
Adjustment	13-12	Rear Shock Absorber Installation	13-44
Oil Change (each fork leg).....	13-12	Spring Replacement	13-44
Front Fork Removal	13-12	Rear Shock Absorber	
Front Fork Installation	13-13	Disassembly (Oil Change)	13-45
Front Fork Disassembly (each		Rear Shock Absorber Assembly ..	13-45
fork leg)	13-14	Rear Shock Absorber Scrapping .	13-45
Front Fork Assembly.....	13-18	Swingarm.....	13-46
Adjuster Assembly Inspection.....	13-23	Swingarm Removal.....	13-46
Base Valve Assembly Inspection .	13-23	Swingarm Installation.....	13-47
Cylinder Unit Inspection.....	13-24	Swingarm Bearing Removal	13-47
Inner Tube Inspection	13-24	Swingarm Bearing Installation	13-47
Guide Bush Inspection.....	13-24	Swingarm Bearing, Sleeve	
Dust Seal/Oil Seal Inspection	13-24	Inspection.....	13-48
Spring Tension Inspection.....	13-25	Drive Chain Guide, Guide Roller,	
Front Fork (KX450D8F).....	13-26	Chain Slipper Wear Inspection..	13-48
Air Pressure	13-26	Tie-Rod, Rocker Arm	13-49
Rebound Damping Adjustment....	13-26	Tie-Rod Removal	13-49
Compression Damping		Tie-Rod Installation	13-49
Adjustment	13-27	Rocker Arm Removal.....	13-49
Oil Change (each fork leg).....	13-27	Rocker Arm Installation.....	13-50
Front Fork Removal	13-27	Tie-Rod and Rocker Arm Bearing	
Front Fork Installation	13-28	Removal	13-50
Front Fork Disassembly (each		Tie-Rod and Rocker Arm Bearing	
fork leg)	13-29	Installation	13-51
Front Fork Assembly.....	13-33	Needle Bearing Inspection.....	13-51
Adjuster Assembly Inspection.....	13-38	Uni-Trak Maintenance	13-52
Base Valve Assembly Inspection .	13-38	Uni-Trak Linkage Inspection	13-52
Cylinder Unit Inspection.....	13-39	Tie-Rod and Rocker Arm Sleeve	
Inner Tube Inspection	13-39	Wear Inspection	13-52
Guide Bush Inspection.....	13-39	Tie-Rod and Rocker Arm	
Dust Seal/Oil Seal Inspection	13-39	Mounting Bolt Bend Inspection .	13-52
Spring Tension Inspection.....	13-40		

Exploded View

No.	Fastener	Torque			Remarks
		N·m	kgf·m	ft·lb	
1	Base Valve Assembly	28	2.9	21	
2	Front Fork Top Plug	30	3.1	22	
3	Front Fork Clamp Bolts (Upper)	20	2.0	15	AL
4	Front Fork Clamp Bolts (Lower)	20	2.0	15	AL
5	Steering Stem Head Nut	98	10	72	
6	Locknut/Adjuster Assembly	29	3.0	21	
7	Adjuster Assembly	58	5.9	43	L
8	Front Axle Clamp Bolts	20	2.0	15	AL

- 9. Screw
- 10. O-ring
- 11. Piston Rod
- 12. Rebound Damping Adjuster Rod
- 13. Subtank
- 14. Cylinder Unit
- 15. Outer Tube
- 16. Washer
- 17. Spacer
- 18. Spring Seat
- 19. Fork Spring
- 20. Bushings
- 21. Washer
- 22. Oil Seal
- 23. Retaining Ring
- 24. Dust Seal
- 25. Inner Tube
- 26. O-ring
- 27. Gasket
- 28. Steering Stem Head
- 29. Steering Stem

AL: Tighten the two clamp bolts alternately two times to ensure even tightening torque.

L: Apply a non-permanent locking agent to the threads.

R: Replacement Parts

13-4 SUSPENSION

Exploded View

KX450D7F ~ D8F

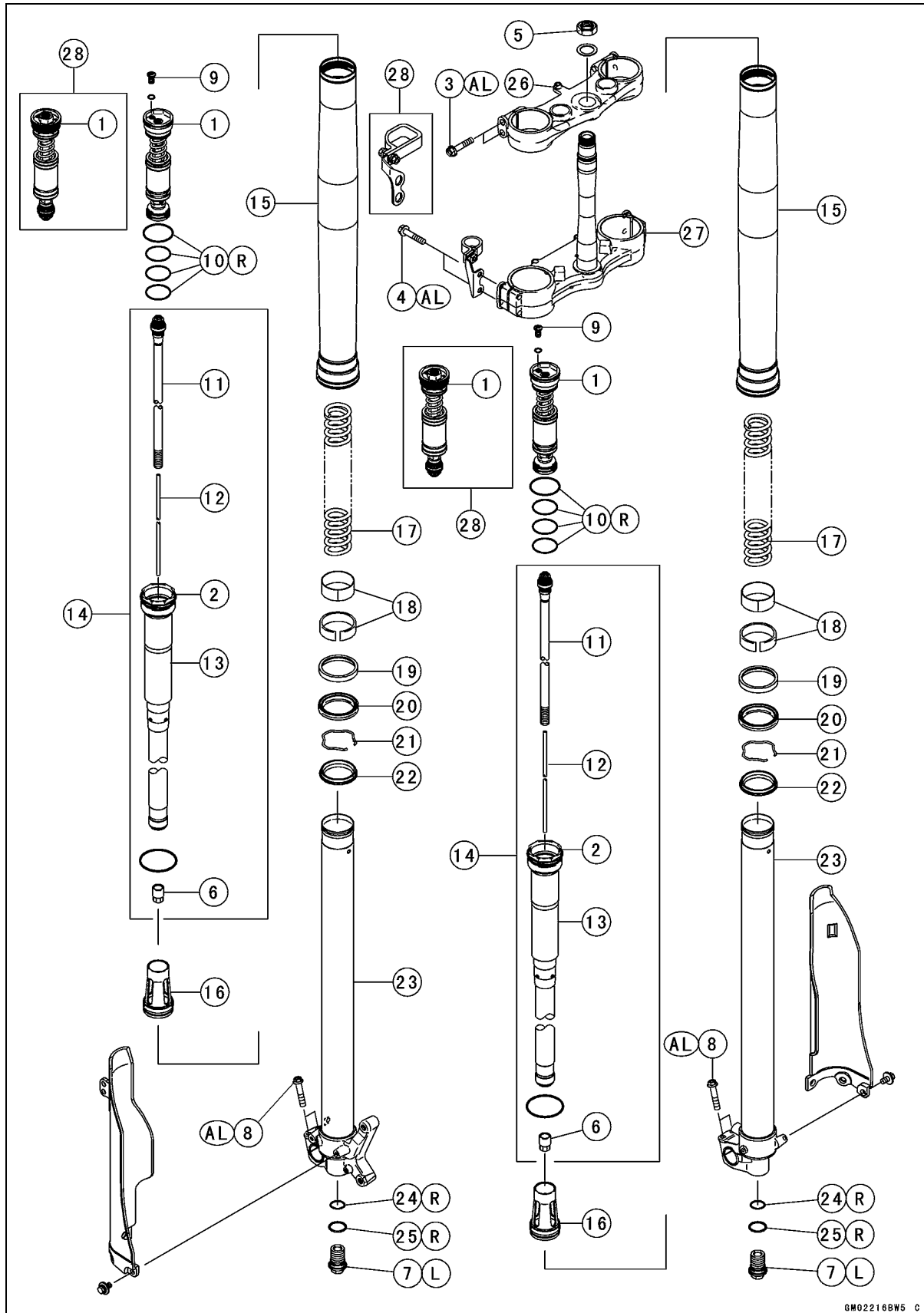

Exploded View

No.	Fastener	Torque			Remarks
		N·m	kgf·m	ft·lb	
1	Base Valve Assembly	28	2.9	21	
2	Front Fork Top Plug	30	3.1	22	
3	Front Fork Clamp Bolts (Upper)	20	2.0	15	AL
4	Front Fork Clamp Bolts (Lower)	20	2.0	15	AL
5	Steering Stem Head Nut	98	10	72	
6	Locknut/Adjuster Assembly	29	3.0	21	
7	Adjuster Assembly	58	5.9	43	L
8	Front Axle Clamp Bolts	20	2.0	15	AL

- 9. Screw
- 10. O-ring
- 11. Piston Rod
- 12. Rebound Damping Adjuster Rod
- 13. Subtank
- 14. Cylinder Unit
- 15. Outer Tube
- 16. Spacer
- 17. Fork Spring
- 18. Bushings
- 19. Washer
- 20. Oil Seal
- 21. Retaining Ring
- 22. Dust Seal
- 23. Inner Tube
- 24. O-ring
- 25. Gasket
- 26. Steering Stem Head
- 27. Steering Stem
- 28. KX450D7F

AL: Tighten the two clamp bolts alternately two times to ensure even tightening torque.

L: Apply a non-permanent locking agent to the threads.

R: Replacement Parts

13-6 SUSPENSION

Exploded View

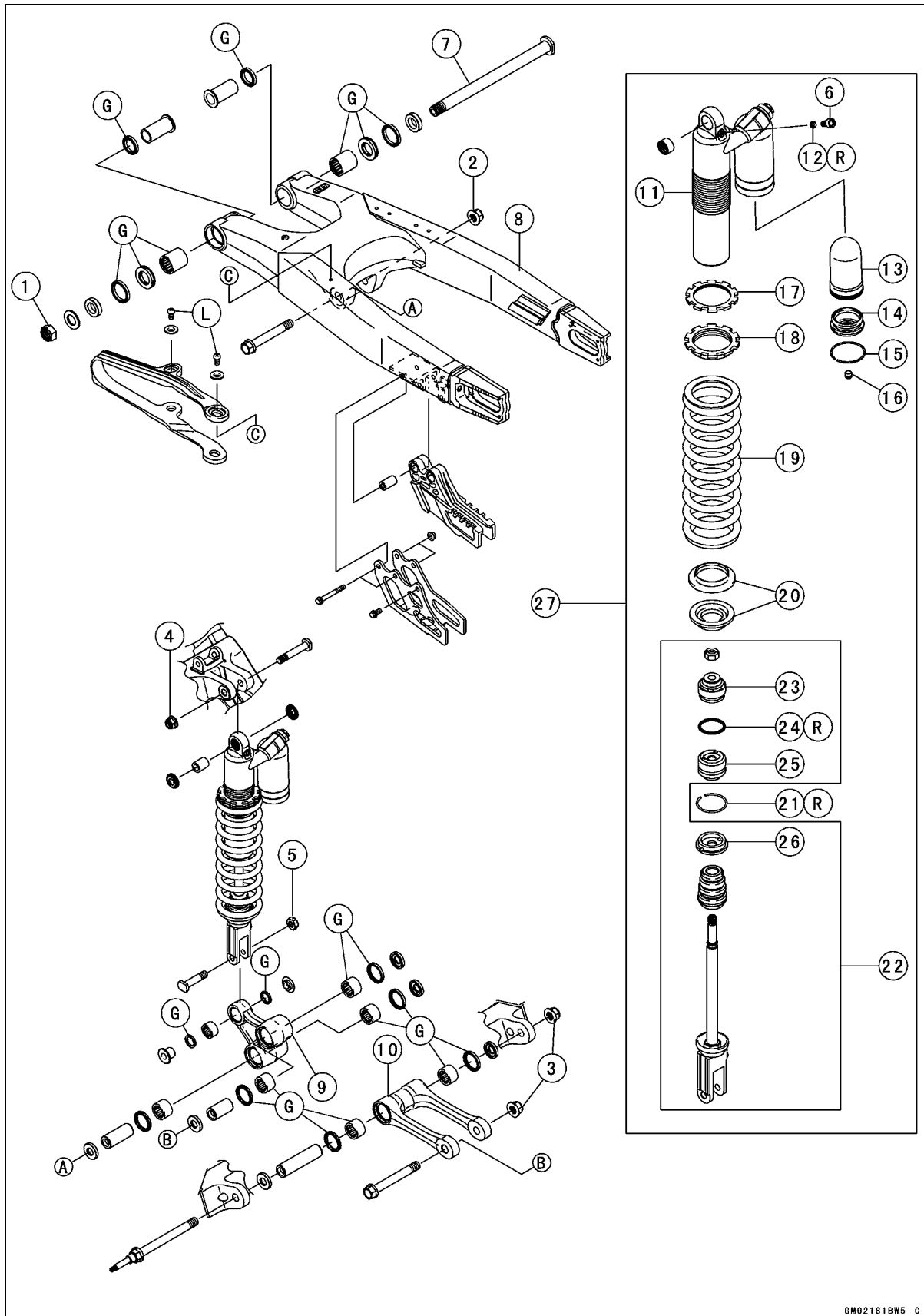

GM02181BWS C

Exploded View

No.	Fastener	Torque			Remarks
		N·m	kgf·m	ft·lb	
1	Swingarm Pivot Shaft Nut	98	10	72	
2	Rocker Arm Pivot Nut (KX450D6F)	83	8.5	61	
	Rocker Arm Pivot Nut (KX450D7F ~)	59	6.0	43	
3	Tie-rod Mounting Nut (Front, Rear) (KX450D6F)	83	8.5	61	
	Tie-rod Mounting Nut (Front, Rear) (KX450D7F ~)	59	6.0	43	
4	Rear Shock Absorber Mounting Nut (Upper)	39	4.0	29	
5	Rear Shock Absorber Mounting Nut (Lower)	34	3.5	25	
6	Air Bleed Bolt	6.4	0.65	56 in·lb	

- 7. Swingarm Pivot Shaft
- 8. Swingarm
- 9. Rocker Arm
- 10. Tie-Rod
- 11. Rear Shock Absorber Cylinder
- 12. O-ring
- 13. Bladder
- 14. Cap
- 15. Circlip
- 16. Valve Cap
- 17. Locknut
- 18. Adjusting Nut
- 19. Spring
- 20. Spring Guides
- 21. Circlip
- 22. Piston Rod Assembly
- 23. Piston
- 24. O-ring
- 25. Oil Seal
- 26. Stopper
- 27. Rear Shock Absorber
- G: Apply grease
- L: Apply a non-permanent locking agent.
- R: Replacement Parts

13-8 SUSPENSION

Specifications

Item	Standard	Service Limit
Front Fork		
Air Pressure	Atmospheric pressure	--- (Adjustable Range)
Rebound Damping Adjustment (from the seated position adjuster turned fully clockwise)	13 clicks counterclockwise (KX450D6F) 9 clicks counterclockwise, (EUR) 10 clicks conterclockwise (KX450D7F) 10 clicks counterclockwise (KX450D8F)	16 clicks (KX450D6F) 20 clicks (KX450D7F ~)
Compression Damping Adjustment (from the seated position adjuster turned fully clockwise)	12 clicks counterclockwise (KX450D6F) 9 clicks counterclockwise, (EUR) 10 clicks conterclockwise (KX450D7F) 10 clicks counterclockwise (KX450D8F)	(Adjustable Range) 16 clicks (KX450D6F) 22 clicks (KX450D7F ~)
Oil Viscosity	KHL15-10 (KAYABA 01) or equivalent	---
Oil Quantity:		---
Outer (Outer/Inner Tubes)	345 mL (11.7 US oz) (KX450D6F) 355 mL (12.00 US oz) (KX450D7F) 350 mL (11.8 US oz) (KX450D8F) (EUR) 350 mL (11.8 US oz) (KX450D6F)	(Adjustable Range) 325 ~ 365 mL (11.0 ~ 12.3 US oz) (KX450D6F) 330 ~ 380 mL (11.2 ~ 12.8 US oz) (KX450D7F ~) 330 ~ 370 mL (11.2 ~ 12.5 US oz) (KX450D6F)
Inner (subtank)	170 mL (5.75 US oz) (KX450D6F) 191 mL (6.46 US oz) (KX450D7F ~)	---
Fork Spring Free Length	480 mm (18.9 in.) (KX450D6F) 470 mm (18.5 in.) (KX450D7F ~)	470 mm (18.5 in.) (KX450D6F) 461 mm (18.1 in.) (KX450D7F ~)
Rear Shock Absorber		
Rebound Damping Adjustment (from the seated position adjuster turned fully clockwise)	11 clicks counterclockwise (KX450D6F) 8 clicks counterclockwise, (EUR) 10 clicks counterclockwise (KX450D7F ~)	(Adjustable Range) 16 clicks (KX450D6F) 22 clicks (KX450D7F ~)

Specifications

Item	Standard	Service Limit
Spring Preload Adjustment (Adjusting nut position from the center of the mounting hole upper)	127.5 mm (5.020 in.) (KX450D6F ~ D7F) 128.5 mm (5.059 in.) (KX450D8F)	(Adjustable Range) 121.5 ~ 138.5 mm (4.783 ~ 5.453 in.) (KX450D6F, D8F) 122.1 ~ 131.6 mm (4.8075 ~ 5.181 in.) (KX450D7F)
Rear Shock Spring Free Length	260 mm (10.2 in.)	255 mm (10.0 in.) (Adjustable Range)
High Speed Compression Damping Adjustment	1-1/6 turns out (KX450D6F) 1-1/2 turns out (KX450D7F) 1 turn out, (EUR) 1-1/2 turns out (KX450D8F)	2 ±0.5 turns out (KX450D6F) 4 turns out (KX450D7F ~) (Adjustable Range)
Low Compression Damping Adjustment (from the seated position adjuster turned fully clockwise)	11 clicks counterclockwise (KX450D6F) 10 clicks counterclockwise (KX450D7F) 8 clicks counterclockwise, (EUR) 10 clicks counterclockwise (KX450D8F)	16 clicks (KX450D6F) 19 clicks (KX450D7F) 22 clicks (KX450D8F)
Gas Pressure	980 kPa (10 kgf/cm ² , 142 psi)	- - -
Tie-Rod, Rocker Arm		
Sleeve Outside Diameter: Tie-rod	19.987 ~ 20.000 mm (0.78688 ~ 0.78740 in.)	19.85 mm (0.781 in.)
Rocker Arm Large	19.987 ~ 20.000 mm 0.78688 ~ 0.78740 in.)	19.85 mm (0.781 in.)
Small	15.950 ~ 16.000 mm (0.62795 ~ 0.62992 in.)	15.92 mm (0.627 in.)
Rocker Arm Mounting Bolt Runout	TIR 0.1 mm (0.004 in.) or less	TIR 0.2 mm (0.008 in.)

EUR: Europe Model

TIR : Total Indicator Reading

13-10 SUSPENSION

Special Tools

Oil Seal & Bearing Remover:
57001-1058

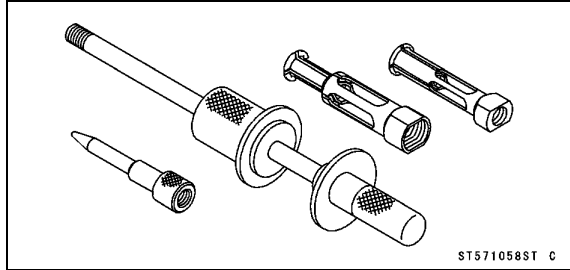

Bearing Remover Shaft, $\phi 9$:
57001-1265

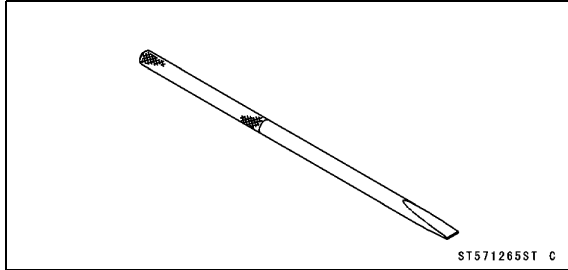

Steering Stem Nut Wrench:
57001-1100

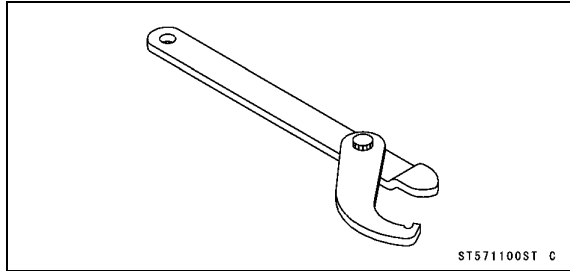

Bearing Remover Head, $\phi 15 \times \phi 17$:
57001-1267

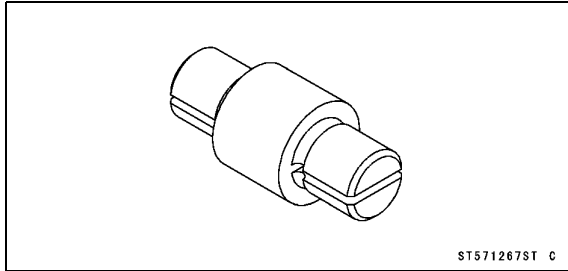

Hook Wrench R37.5, R42:
57001-1101

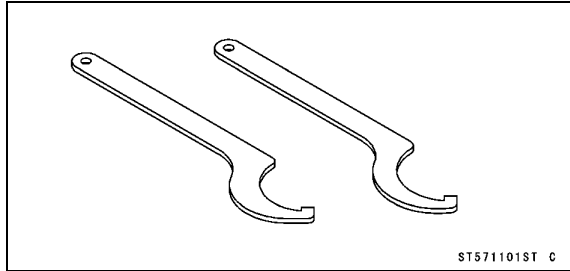

Fork Oil Seal Driver, $\phi 48$:
57001-1509

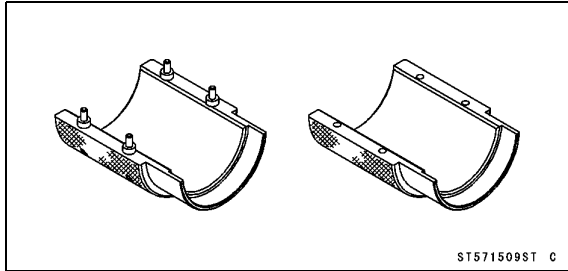

Bearing Driver Set:
57001-1129

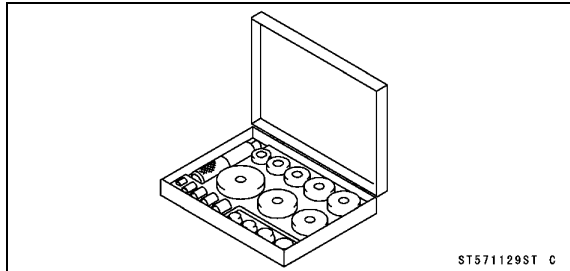

Top Plug Wrench, 49 mm:
57001-1653

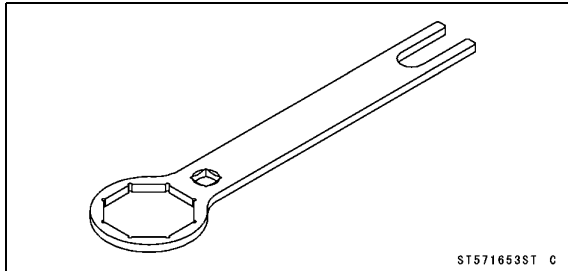

Jack:
57001-1238

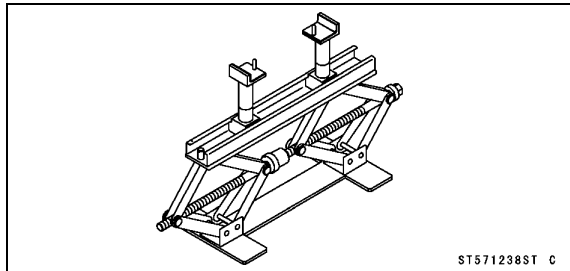

Top Plug Wrench, 36 mm:
57001-1705

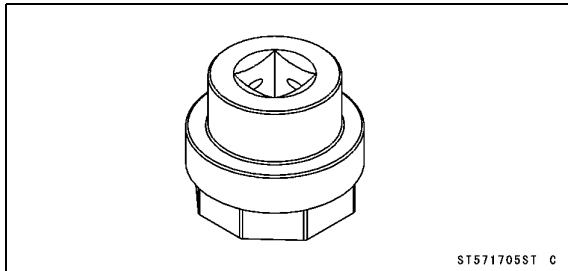

Front Fork (KX450D6F ~ D7F)

Air Pressure

The standard air pressure in the front fork legs is atmospheric pressure. Air pressure in the fork legs increase with normal use, so the fork action stiffens during operation. Release air pressure from the fork legs prior to each race through the pressure relief screw located in each front fork cap.

- Place the jack under the frame so that the front wheel off the ground.

Special Tool - Jack: 57001-1238

- Remove the screws [A] at the top of the front fork top plugs to let the air pressure equalize.

NOTE

- Do not use the sidestand when adjusting the air pressure.
- Adjust the air pressure when the front forks are cold.

- Replace the O-ring with a new one.
- Install the screw.

Rebound Damping Adjustment

- Place the jack under the frame so that the front wheel off the ground.

Special Tool - Jack: 57001-1238

- Clean the bottom of the fork tubes.
- Remove the caps on the bottom of the fork tubes.
- To adjust rebound damping, turn the adjuster [A] on the front fork cylinder valve with the blade of a screwdriver until you feel a click. Adjust the rebound damping to suit your preference under special condition.

NOTE

- The left and right fork legs must have the same shock damping.

Seated positions adjuster turned fully clockwise [A].

Rebound Damping Adjuster Setting

Standard: 13 clicks [B] (KX450D6F)

9 clicks, (EUR) 10 clicks (KX450D7F)

Softer (Counterclockwise) [C]

Harder (Clockwise) [D]

*: Number of turns counterclockwise usable range;

- 16 clicks or more (KX450D6F)

- 20 clicks or more (KX450D7F)

Counterclockwise from the fully seated position

- Put the caps into the bottom of the fork tubes.

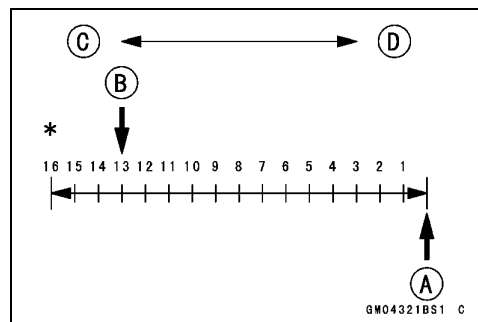
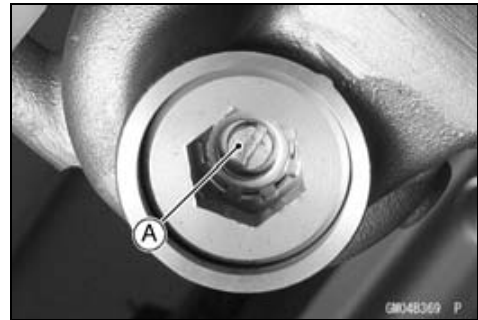
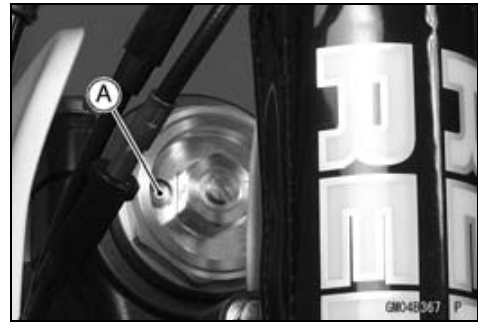

13-12 SUSPENSION

Front Fork (KX450D6F ~ D7F)

Compression Damping Adjustment

- Place the jack under the frame so that the front wheel off the ground.

Special Tool - Jack: 57001-1238

- To adjust compression damping, turn the adjuster [A] on the front fork top plugs with the blade of a screwdriver until you feel a click. Adjust the compression damping to suit your preference under special condition.

NOTE

- The left and right fork legs must have the same shock damping.

Seated positions: adjuster turned fully clockwise [A].

Compression Damping Adjuster Setting

Standard: 12 clicks [B] (KX450D6F)
9 clicks, (EUR) 10 clicks (KX450D7F)
Softer (Counterclockwise) [C]
Harder (Clockwise) [D]

- *: Number of turns counterclockwise usable range;
 - 16 clicks or more (KX450D6F)
 - 22 clicks or more (KX450D7F)Counterclockwise from the fully seated position

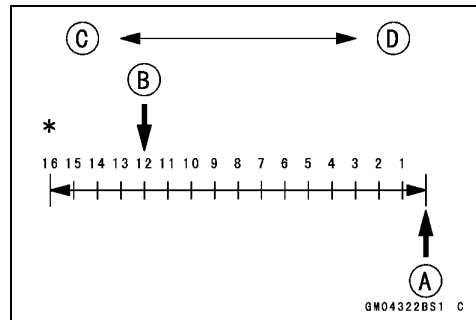
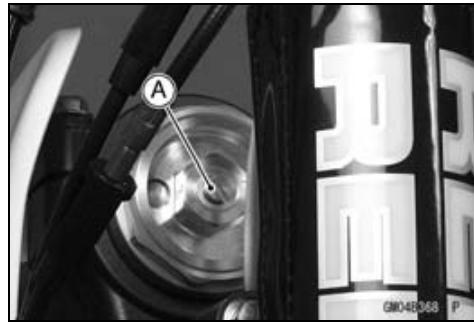

Oil Change (each fork leg)

- Refer to Front Fork Oil Change in the Periodic Maintenance chapter.

Front Fork Removal

- Unscrew the bolts [A], and remove the front brake hose clamps [B].

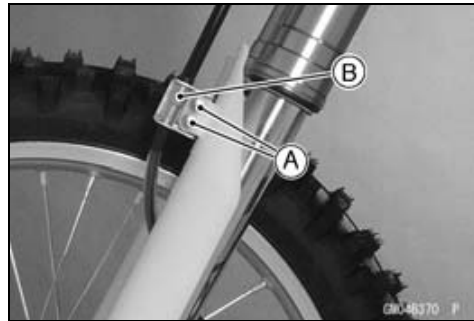

- Remove:
 - Front wheel (see Front Wheel Removal in the Wheels/Tires chapter)
 - Bolts [A]
- Remove the caliper [B] from the fork leg to be removed, and rest the caliper on some kind of stand so that it doesn't dangle.
- Remove:
 - Bolts [C]
 - Fork Protector [D]

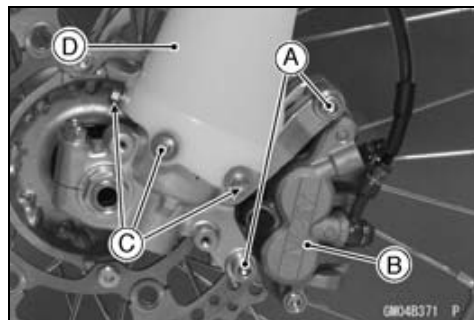

Front Fork (KX450D6F ~ D7F)

- Loosen the upper [A], and lower [B] fork clamp bolts.

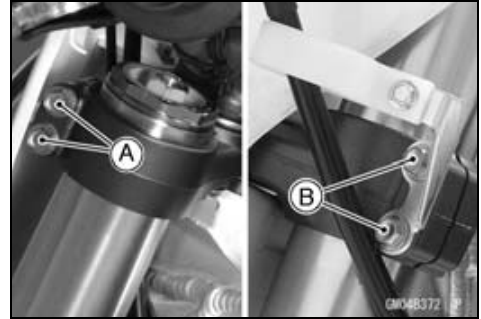

- Remove the front fork.
 - With a twisting motion [A], work the fork leg [B] down and out.

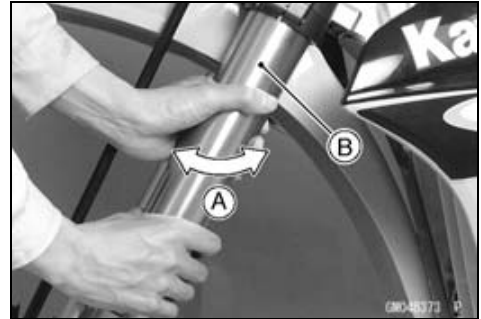

Front Fork Installation

- Install the fork so that the distance between the top end of the outer tube and the upper surface of the steering stem head is specified dimension.
 - [A] 7 mm (0.28 in.) (KX450D6F)
 - 8 mm (0.31 in.) (KX450D7F)
- Route the cables and hose according to the Cable, Wire, and , Hose Routing section in the Appendix chapter.
- Install the front wheel (see Front Wheel Installation in the Wheels/Tires chapter).
- Tighten the fork clamp bolts.



Torque - Front Fork Clamp Bolts (Upper): 20 N·m (2.0 kgf·m, 15 ft·lb)

Front Fork Clamp Bolts (Lower): 20 N·m (2.0 kgf·m, 15 ft·lb)

NOTE

- Tighten the two clamp bolts alternately two times to ensure even tightening torque.
- Tighten:
 - Torque - Front Caliper Mounting Bolts: 25 N·m (2.5 kgf·m, 18 ft·lb)**
- Check the front brake operation after installation.

13-14 SUSPENSION

Front Fork (KX450D6F ~ D7F)

Front Fork Disassembly (each fork leg)

- Loosen the front fork upper clamp bolts [A].



- Loosen the fork top plug (subtank) [A] with the top plug wrench [B].

Special Tool - Top Plug Wrench, 49 mm: 57001-1653 [B]

- Remove the front fork (see Front Fork Removal).

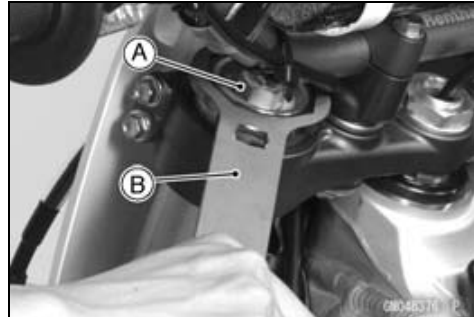

NOTE

○Set rebound and compression damping setting to the softest settings before disassembling to prevent the needle of adjusters from damaging. Record the setting before turning the adjuster.

- Thoroughly clean the fork before disassembly.

CAUTION

Be careful not scratch the inner tube and not to damage the dust seal.

Avoid scratching or damaging the inner tube or the dust seal. Use a mild detergent and sponge out dirt with plenty of water.

- Using the top plug wrench [A], remove the fork top plug [B] (subtank) from the outer tube and slowly slide down the outer tube [C].

Special Tool - Top Plug Wrench, 49 mm: 57001-1653

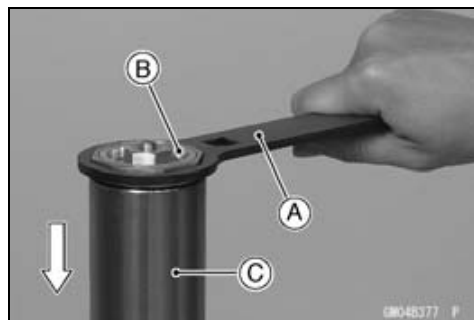

Front Fork (KX450D6F ~ D7F)

- Place a drain pan under the front fork and drain fork oil [A].

NOTE

○ Pump the fork tube several times to discharge the fork oil.



- Raise the outer tube and temporarily install the fork top plug [A] (subtank) to the outer tube [B] with the top plug wrench [C].

Special Tool - Top Plug Wrench, 49 mm: 57001-1653

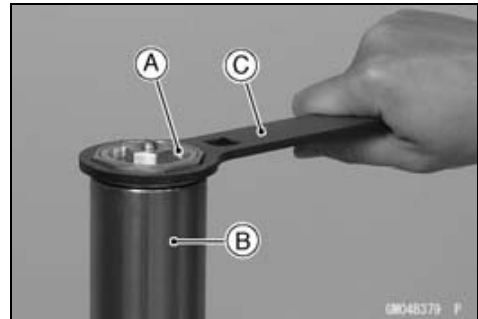

- Hold the axle holder [A] with a vise.
- Protect the axle holder with a rag when using a vise.
- Loosen the adjuster assembly [B] completely.

⚠ WARNING

Clamping the axle holder too tight can damage it which will affect riding stability. Do not clamp the axle holder too tight.

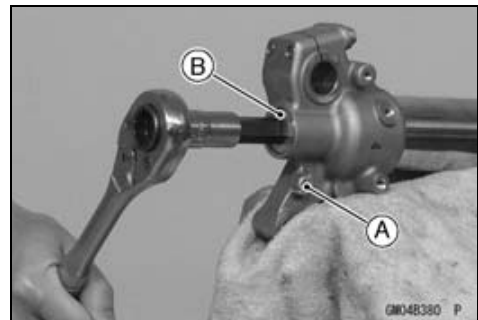

- Compress the outer tube by hands and install the top plug wrench [A] between the axle holder bottom [B] and locknut [C].

Special Tool - Top Plug Wrench, 49 mm: 57001-1653

⚠ WARNING

Be careful of reaction force in spring and fix surely so that the special tool should not come off. Do not place the finger etc. while servicing.

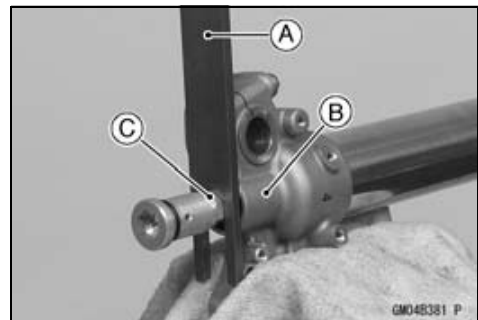

- Hold the locknut [A] with a wrench [B] and remove the adjuster assembly [C].

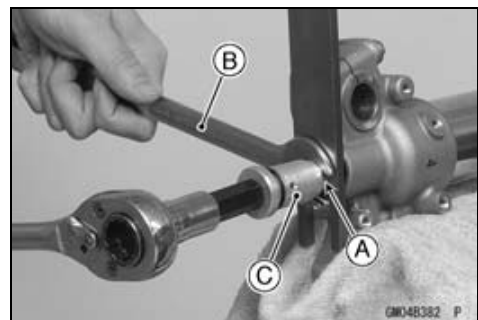

13-16 SUSPENSION

Front Fork (KX450D6F ~ D7F)

- Remove the push rod [A].

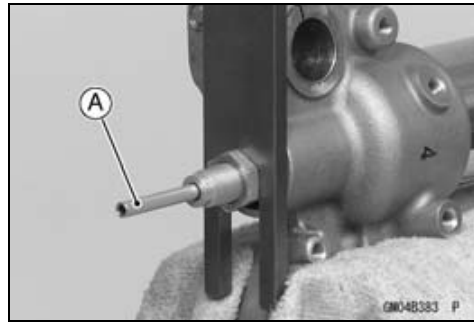

- With the outer tube compressed by hands, remove the top plug wrench [A].

CAUTION

Removing the locknut and pushing the piston rod thread into the cylinder unit will damage the oil seal. Do not remove the locknut from the piston rod.

- Remove the fork leg from the vise.
- Loosen the fork top plug (subtank) [A] with the top plug wrench [B].
Special Tool - Top Plug Wrench, 49 mm: 57001-1653 [B]

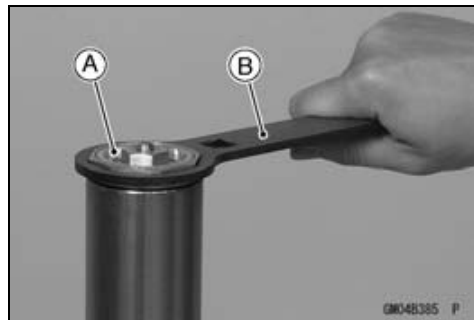
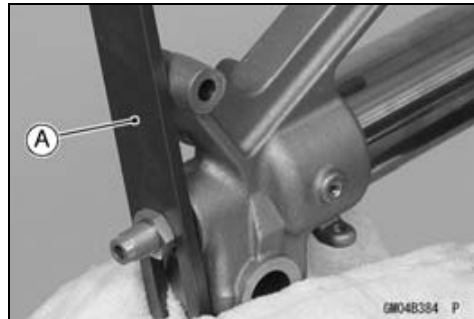

- Remove:
 - Cylinder Unit [A]
 - Spring Seat [B]
 - Spacer [C]
 - Washer [D]
 - Fork Spring [E]

CAUTION

Disassembling the cylinder unit can lead to trouble. Do not disassemble the cylinder unit.

- Remove the dust seal [A] and the retaining ring [B].

CAUTION

Be careful not to scratch the inner tube.

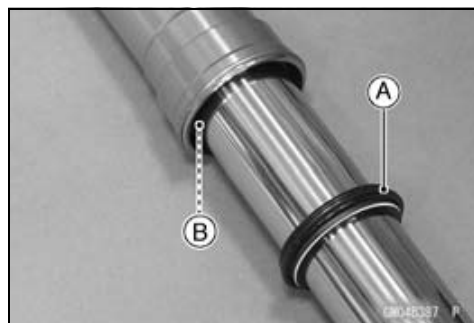
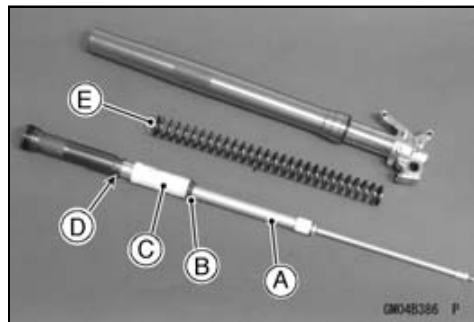

Front Fork (KX450D6F ~ D7F)

- Grasp the outer tube and stroke [A] the inner tube several times. The shock to fork seal separates the inner tube from the outer tube.

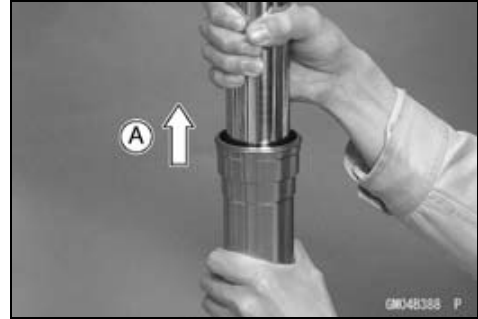

- Remove the following parts from the inner tube.
 - [A] Guide Bushes
 - [B] Washer
 - [C] Oil Seal
 - [D] Retaining Ring
 - [E] Dust Seal

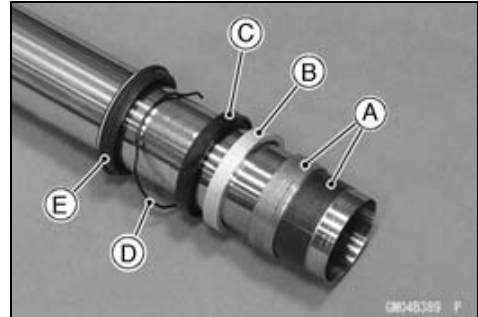

- Holding the top plug wrench [A] with a vise, loosen the base assembly [B] on the subtank [C].

Special Tool - Top Plug Wrench, 49 mm: 57001-1653

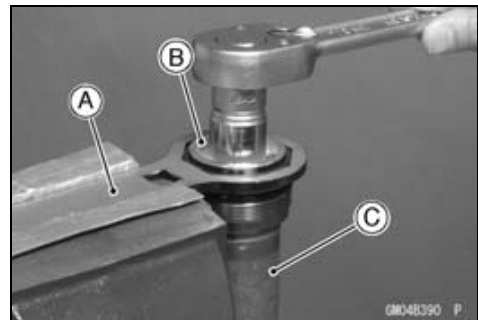

- Remove the base valve assembly [A] from the subtank [B].

NOTE

○ Slowly compress the piston rod until it stops so that the base valve assembly can be removed easily.

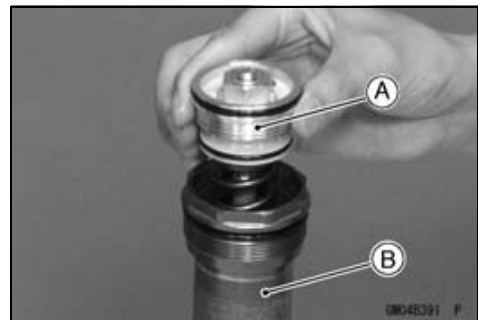

CAUTION

**Disassembling the base valve assembly can lead to trouble.
Do not disassemble the base valve assembly.**

- Drain the fork oil [A] from the cylinder unit [B] by pumping the piston rod several times

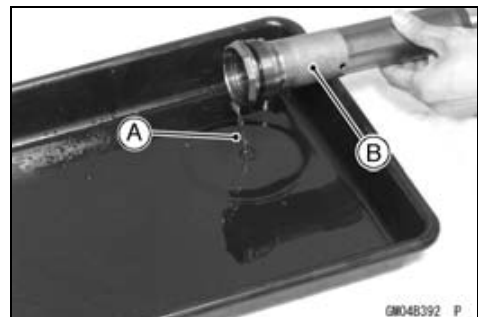

13-18 SUSPENSION

Front Fork (KX450D6F ~ D7F)

Front Fork Assembly

- When the fork tubes are not disassembled, hold the fork inverted position for more than 20 minutes to allow the fork oil to fully drain.

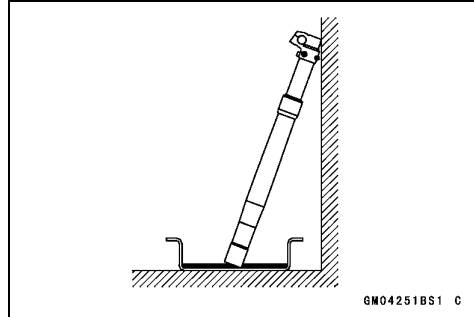

- Replace the following with new ones:
 - Dust Seal [A]
 - Retaining Ring [B]
 - Oil Seal [C]
 - Guide Bushes [D]
- Place an oil coated plastic bag [E] over the end of the inner tube to protect the oil seals.
- The inner tube guide bush groove has a sharp edge [F] that cut out the sealing lip of the seals as they are pushed down over the inner tube.
- Install in order these parts on the inner tube.

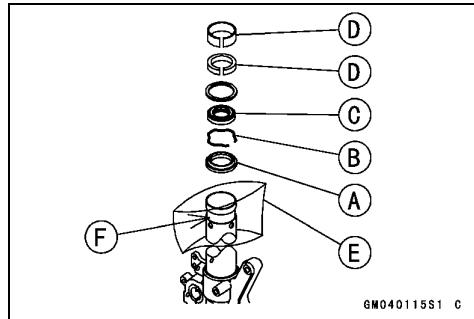

- When assembling the new outer tube guide bush [A], hold the used guide bush [B] against the new one, and tap the used guide bush with the fork oil seal driver [C] until it stops.

Special Tool - Fork Oil Seal Driver, ϕ 48: 57001-1509

- After installing the washer, install the oil seal by using the fork oil seal driver.

Special Tool - Fork Oil Seal Driver, ϕ 48: 57001-1509

- Install the retaining ring to the outer tube.
- Push the dust seal into the outer tube, and put the spring band on the dust seal.
- Clean the threads [A] of subtank and base valve assembly.

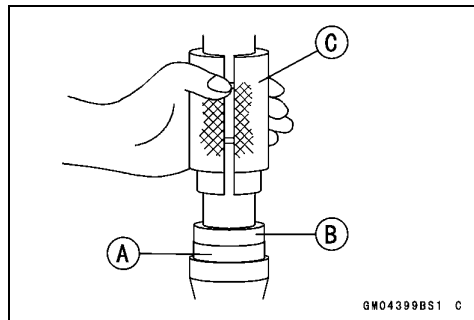

Front Fork (KX450D6F ~ D7F)

- With the piston rod in fully compressed position, pour the specified amount of fork oil [A].

Recommended Oil: KHL15-10 (KAYABA01) or equivalent

Recommended Quantity: 170 ml (5.75 US oz) (KX450D6F)
191 ml (6.46 US oz) (KX450D7F)

NOTE

○ Plug the two oil holes on the subtank [B] with fingers.

- Pump [A] the piston rod [B] slowly several times to expel air.

- Replace the O-rings [A] on the base valve assembly with new ones.
- Apply specified fork oil to the O-rings [A] [B] and bushings [C] on the base valve assembly.

- With the piston rod held immovable in fully compressed position [A], gently install the base valve assembly [B] to the subtank.
- Screw in the base valve assembly in the subtank when the piston rod extends.

NOTE

○ When it is hard to screw in the base valve assembly, pull down the piston rod a little.

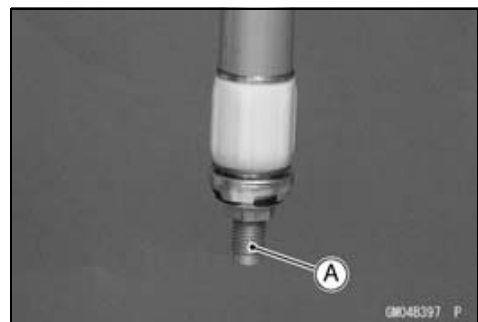
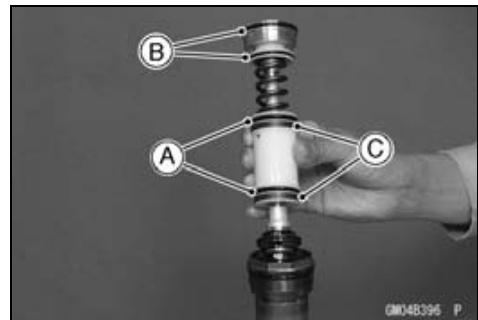
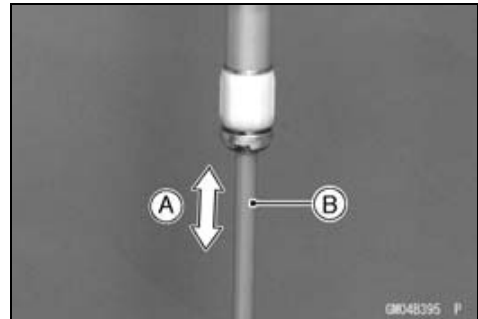

13-20 SUSPENSION

Front Fork (KX450D6F ~ D7F)

- Holding the top plug wrench [A] with a vise.
- Holding the subtank [B] with the top plug wrench, torque the base valve assembly [C].

Special Tool - Top Plug Wrench, 49 mm: 57001-1653

Torque - Base Valve Assembly: 28 N·m (2.9 kgf·m, 21 ft·lb)

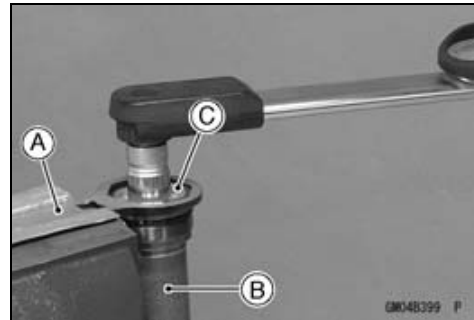

- Protect the piston rod end [A] with a rag [B] to prevent fork damage.
- Discharge the extra oil off the cylinder unit by pumping [C] the piston rod to full stroke.

CAUTION

Be careful not to bend or damage the piston rod when the piston rod is stroked. Service carefully because oil flies out from the oil hole of the cylinder unit.

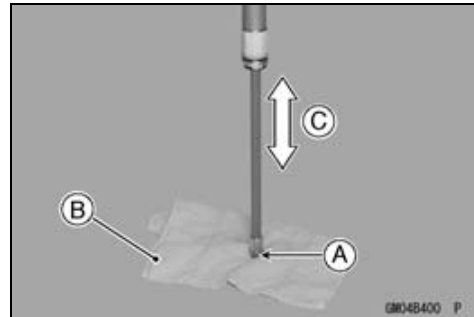

NOTE

- Set the compression damper setting to the softest.
 - Check the piston rod sliding surface for damage.
 - Apply fork oil to the piston rod sliding surface.
- Drain the extra oil from the subtank oil hole [A].

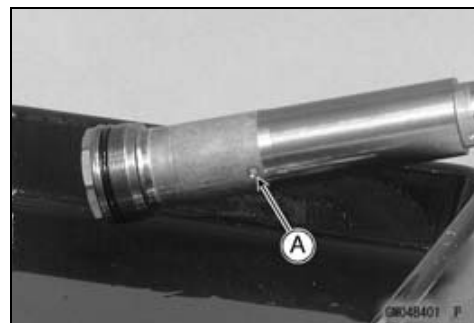

- With the cylinder unit in horizontal position, move [A] the piston rod [B] by hand to inspect it if operating smoothly.
- If the piston rod is not extend, remove the base valve assembly and perform the air bleeding (pour the specified amount fork oil and discharge an excess of oil).

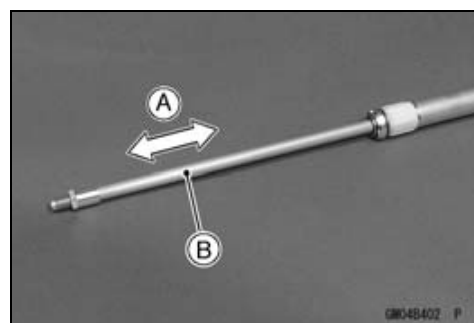

Front Fork (KX450D6F ~ D7F)

- Make sure about 16 mm (0.63 in.) [A] of push rod thread is exposed from the locknut [B].

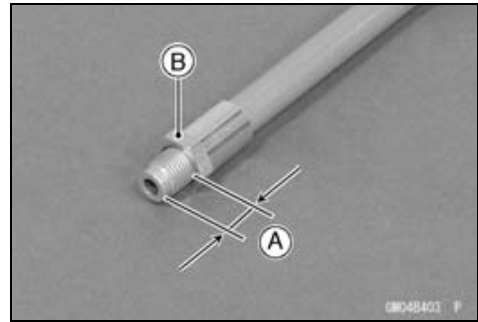

- Completely wipe off the fork oil from the spring [A], collar [B] and cylinder unit [C].
- Insert above-mentioned parts into the fork.

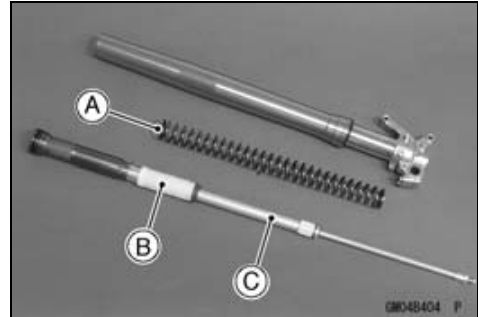

- Temporarily tighten the fork top plug [A] (subtank) using the top plug wrench.

Special Tool - Top Plug Wrench, 49 mm: 57001-1653 [B]

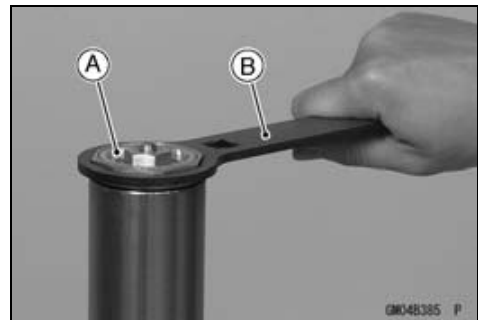

- Clamp the axle holder with a vise.
- Protect the axle holder with a rag when using a vise.

⚠ WARNING

Clamping the axle holder too tight can damage it which will affect riding stability.
Do not clamp the axle holder too tight.

- Compress the outer tube by hands and install the top plug wrench [A] between the axle holder bottom and locknut.
- Special Tool - Top Plug Wrench, 49 mm: 57001-1653**

⚠ WARNING

Be careful of reaction force in spring and fix surely so that special tool should not come off.
Do not place the fingers etc. while serving.

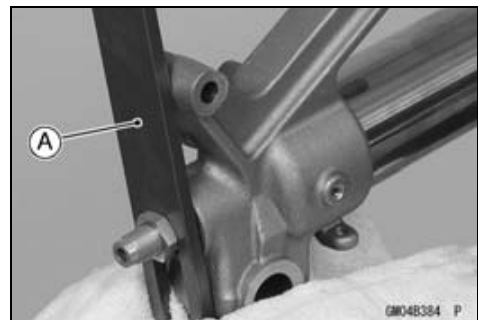

13-22 SUSPENSION

Front Fork (KX450D6F ~ D7F)

- Insert the push rod [A] into the piston rod.

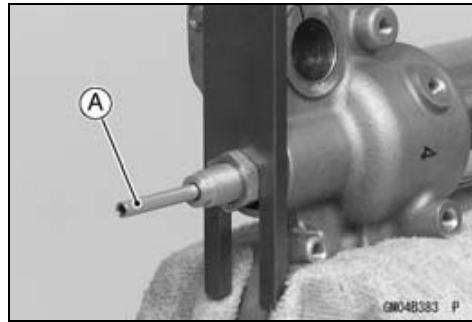

- Replace the O-ring and gasket on the adjuster assembly with new ones and apply specified fork oil to the O-ring.
- Slowly turn the adjuster assembly [A] clockwise until resistance is felt and check the clearance between the locknut [B] and adjuster assembly [A] to provide more than 1 mm (0.04 in.) [C].

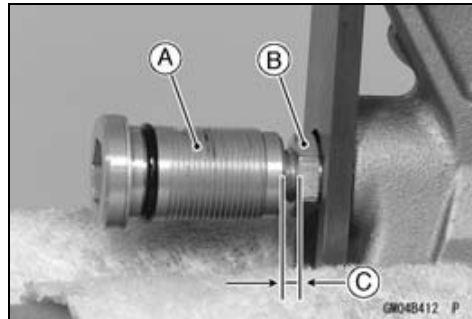

- Turn the locknut [A] counterclockwise until it contacts with the adjuster assembly [B].
- With the locknut held immovable using a wrench, tighten the adjuster assembly to the specified torque.

Torque - Locknut/Adjuster Assembly: 29 N·m (3.0 kgf·m, 21 ft·lb)

- With the outer tube compressed by hands, remove the top plug wrench.

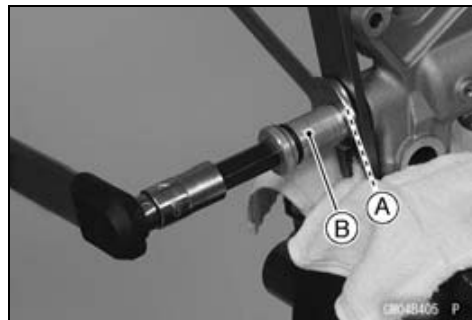

- Apply a non-permanent locking agent to the threads of adjuster assembly.
- Torque the adjuster assembly [A].

Torque - Adjuster Assembly: 58 N·m (5.9 kgf·m, 43 ft·lb)



- Loosen and remove the fork top plug (subtank) from the outer tube and slowly slide down the outer tube.

Special Tool - Top Plug Wrench, 49 mm: 57001-1653

- Pour [A] the specified amount of fork oil into the outer tube.

Recommended Oil: KHL15-10 (KAYABA01) or equivalent

Recommended Quantity:
345 mL (11.7 US oz) (KX450D6F)
(Europe Model) 350 mL (11.8 US oz) (KX450D6F)
355 ml (12.00 US oz) (KX450D7F)



Front Fork (KX450D6F ~ D7F)

- Raise the outer tube and temporarily tighten the fork top plug (subtank).
Special Tool - Top Plug Wrench, 49 mm: 57001-1653
- After installing the front fork, torque the top plug [A].
Special Tool - Top Plug Wrench, 49 mm: 57001-1653 [B]

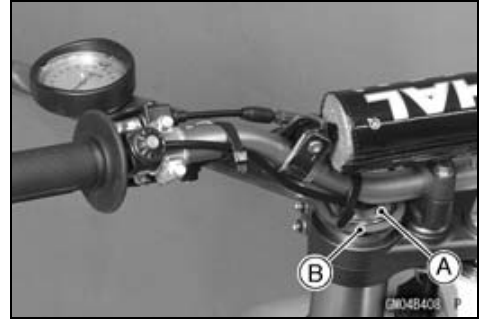

The torque of fork top plug is specified to **30 N·m (3.1 kgf·m, 22 ft·lb)**, however, when you use the top plug wrench (special tool) [A] reduce the torque to 90% of the specified value [**27 N·m (2.8 kgf·m, 20 ft·lb)**] due to the distance [B] between the center of the square hole, where the torque wrench is fitted, and that of the octagonal hole of the wrench.

This torque value [**27 N·m (2.8 kgf·m, 20 ft·lb)**] is applicable when you use a torque wrench whose length gives leverage of approximately 310 mm between the grip point to the center of the coupling square.

Torque - Front Fork Top Plug: 30 N·m (3.1 kgf·m, 22 ft·lb)

Adjuster Assembly Inspection

- Inspect the adjuster assembly [A] and push rod [B] for damage.
- ★ If they are damaged, replace them with new ones.
- Replace the gasket [C] and O-ring [D] on the adjuster assembly with new ones.

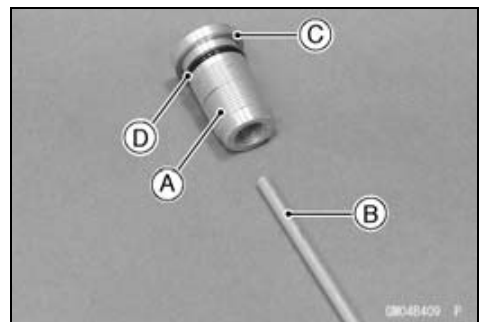
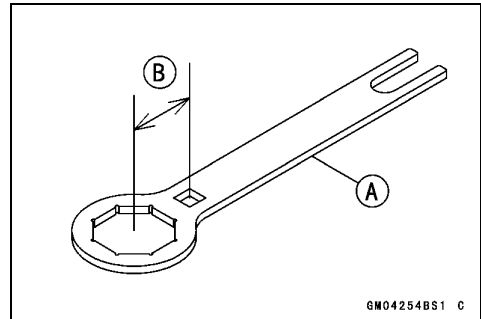

Base Valve Assembly Inspection

- Inspect the threads portion [A], bushing [B] and spring [C] of base valve assembly [D] for damage.
- ★ If they are damaged, replace base valve assembly with new one.
- Replace the O-rings [E] with new ones.

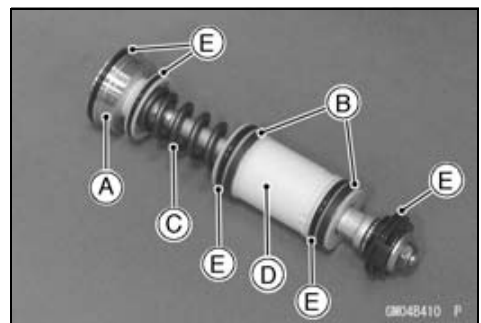

13-24 SUSPENSION

Front Fork (KX450D6F ~ D7F)

Cylinder Unit Inspection

- Inspect the piston rod [B] of cylinder unit [A] for scratches or bending.
- ★ If it has scratches or is bent, replace cylinder unit with a new one.

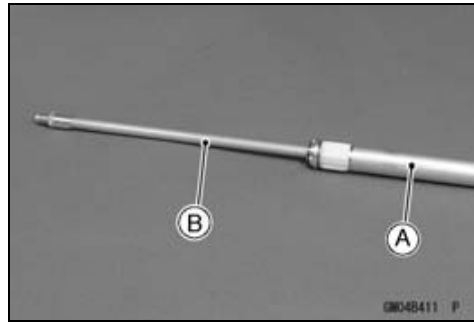

Inner Tube Inspection

- Visually inspect the inner tube [A], repair any damage.
- Nick or rust damage can sometimes be repaired by using a wet-stone to remove sharp edges or raised areas which cause seal damage.
- ★ If the damage is not repairable, replace the inner tube. Since damage to the inner tube damages the oil seal, replace the oil seal whenever the inner tube is repaired or replaced.

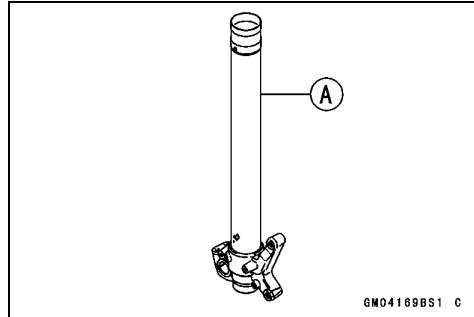

- Temporarily assemble the inner [A] and outer tubes [B], and pump them back and forth manually to check for smooth operation.

CAUTION

If the inner tube is badly bent or creased, replace it. Excessive bending, followed by subsequent straightening, can weaken the inner tube.

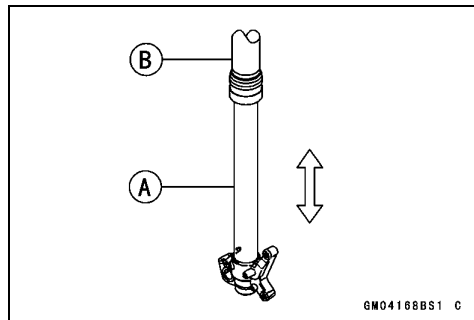

Guide Bush Inspection

- Visually inspect the guide bushes [A], and replace them if necessary.

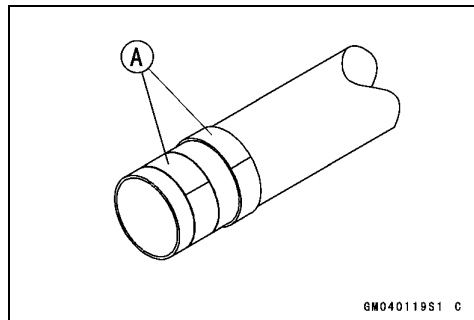

Dust Seal/Oil Seal Inspection

- Inspect the dust seal [A] for any signs of deterioration or damage.
- ★ Replace it if necessary.
- Replace the oil seal [B] with a new one whenever it has been removed.

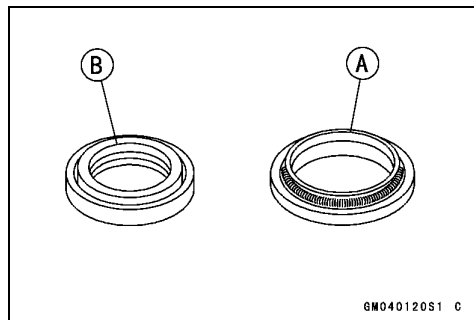

Front Fork (KX450D6F ~ D7F)*Spring Tension Inspection*

- Since a spring becomes shorter as it weakens, check its free length [A] to determine its condition.
- ★ If the spring of either fork leg is shorter than the service limit, it must be replaced. If the length of a replacement spring and that of the remaining spring vary greatly, the remaining spring should also be replaced in order to keep the fork legs balanced from motorcycle stability.

Fork Spring Free Length

Standard:	480 mm (18.9 in.) (KX450D6F)
	470 mm (18.5 in.) (KX450D7F)
Service Limit:	470 mm (18.5 in.) (KX450D6F)
	461 mm (18.1 in.) (KX450D7F)

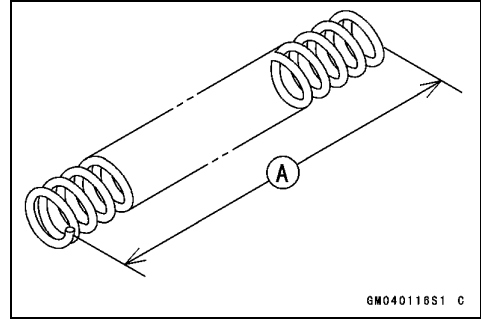

13-26 SUSPENSION

Front Fork (KX450D8F)

Air Pressure

The standard air pressure in the front fork legs is atmospheric pressure. Air pressure in the fork legs increase with normal use, so the fork action stiffens during operation. Release air pressure from the fork legs prior to each race through the pressure relief screw located in each front fork cap.

- Place the jack under the frame so that the front wheel off the ground.

Special Tool - Jack: 57001-1238

- Remove the screws [A] at the top of the front fork top plugs to let the air pressure equalize.

NOTE

○Do not use the sidestand when adjusting the air pressure.

○Adjust the air pressure when the front forks are cold.

- Replace the O-ring with a new one.
- Install the screw.

Rebound Damping Adjustment

- Place the jack under the frame so that the front wheel off the ground.

Special Tool - Jack: 57001-1238

- Clean the bottom of the fork tubes.
- Remove the caps on the bottom of the fork tubes.
- To adjust rebound damping, turn the adjuster [A] on the front fork cylinder valve with the blade of a screwdriver until you feel a click. Adjust the rebound damping to suit your preference under special condition.

NOTE

○The left and right fork legs must have the same shock damping.

Seated positions adjuster turned fully clockwise [A].

Rebound Damping Adjuster Setting

Standard: 10 clicks [B]

Softer (Counterclockwise) [C]

Harder (Clockwise) [D]

*: Number of turns counterclockwise usable range - 20 clicks or more

Counterclockwise from the fully seated position

- Put the caps into the bottom of the fork tubes.

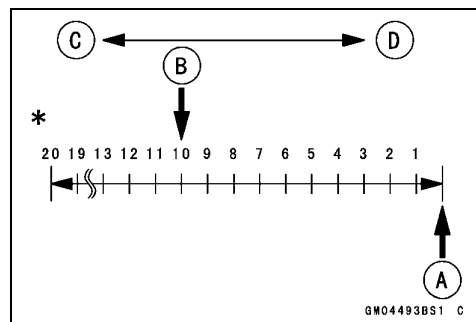
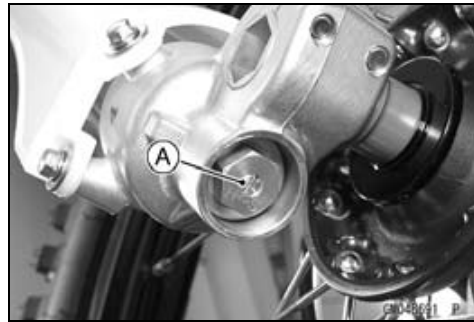

Front Fork (KX450D8F)

Compression Damping Adjustment

- Place the jack under the frame so that the front wheel off the ground.

Special Tool - Jack: 57001-1238

- To adjust compression damping, turn the adjuster [A] on the front fork top plugs with the blade of a screwdriver until you feel a click. Adjust the compression damping to suit your preference under special condition.

NOTE

- The left and right fork legs must have the same shock damping.

Seated positions: adjuster turned fully clockwise [A].

Compression Damping Adjuster Setting

- Standard:** 10 clicks [B]
- Softer (Counterclockwise) [C]**
- Harder (Clockwise) [D]**

- *: Number of turns counterclockwise usable range - 22 clicks or more Counterclockwise from the fully seated position

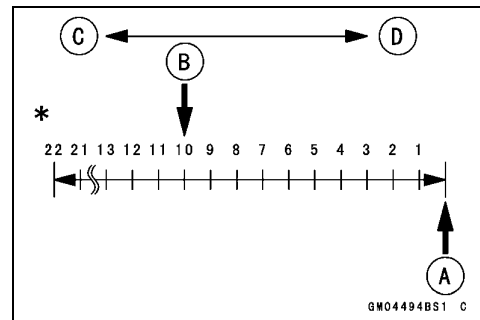

Oil Change (each fork leg)

- Refer to Front Fork Oil Change in the Periodic Maintenance chapter.

Front Fork Removal

- Remove:
 - Number Plate
- Unscrew the bolts [A], and remove the front brake hose clamps [B].

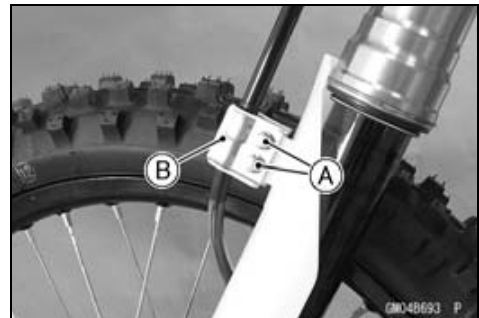

- Remove:
 - Front wheel (see Front Wheel Removal in the Wheels/Tires chapter)
 - Bolts [A]
- Remove the caliper [B] from the fork leg to be removed, and rest the caliper on some kind of stand so that it doesn't dangle.
- Remove:
 - Bolts [C]
 - Fork Protector [D]

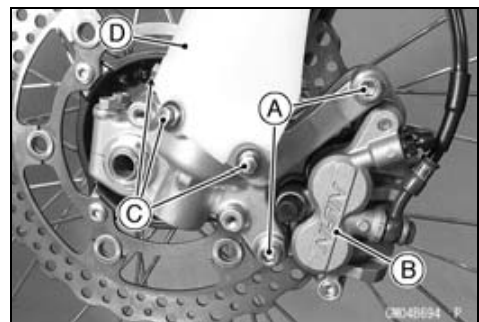

13-28 SUSPENSION

Front Fork (KX450D8F)

- Loosen the upper [A], and lower [B] fork clamp bolts.

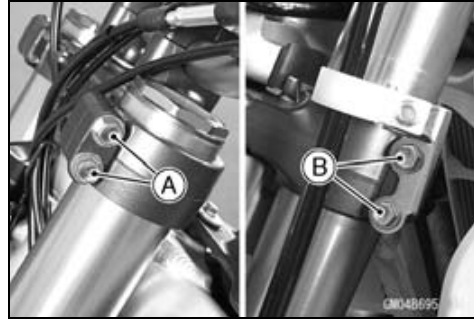

- Remove the front fork.
 - With a twisting motion [A], work the fork leg [B] down and out.

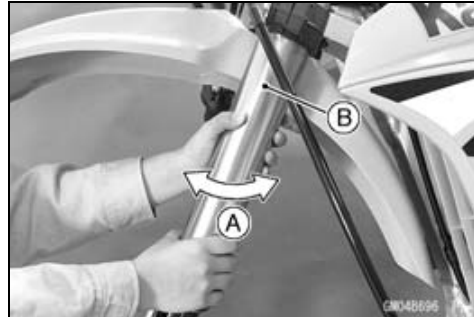

Front Fork Installation

- Install the fork so that the distance between the top end of the outer tube and the upper surface of the steering stem head is specified dimension.
[A] 8 mm (0.31 in.)
- Route the cables and hose according to the Cable, Wire, and , Hose Routing section in the Appendix chapter.
- Install the front wheel (see Front Wheel Installation in the Wheels/Tires chapter).
- Tighten the fork clamp bolts.

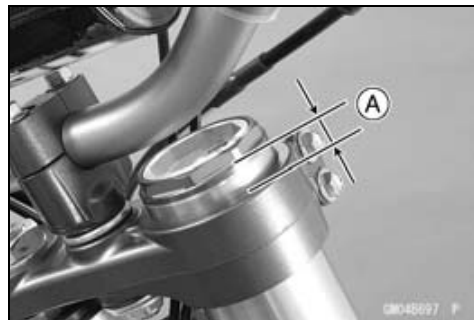

Torque - Front Fork Clamp Bolts (Upper): 20 N·m (2.0 kgf·m, 15 ft·lb)

Front Fork Clamp Bolts (Lower): 20 N·m (2.0 kgf·m, 15 ft·lb)

NOTE

○ Tighten the two clamp bolts alternately two times to ensure even tightening torque.

- Tighten:
Torque - Front Caliper Mounting Bolts: 25 N·m (2.5 kgf·m, 18 ft·lb)
- Check the front brake operation after installation.

Front Fork (KX450D8F)

Front Fork Disassembly (each fork leg)

- Loosen the front fork upper clamp bolts [A].
- Loosen the fork top plug (subtank) [A] with the top plug wrench [B].
- **Special Tool - Top Plug Wrench, 49 mm: 57001-1653 [B]**
- Remove the front fork (see Front Fork Removal).

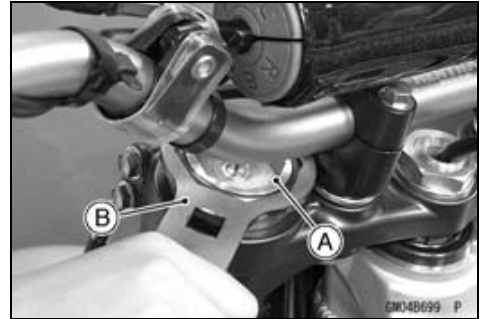

NOTE

- *Set rebound and compression damping setting to the softest settings before disassembling to prevent the needle of adjusters from damaging. Record the setting before turning the adjuster.*
- Thoroughly clean the fork before disassembly.

CAUTION

**Be careful not scratch the inner tube and not to damage the dust seal.
Avoid scratching or damaging the inner tube or the dust seal. Use a mild detergent and sponge out dirt with plenty of water.**

- Using the top plug wrench [A], remove the fork top plug [B] (subtank) from the outer tube and slowly slide down the outer tube [C].
- **Special Tool - Top Plug Wrench, 49 mm: 57001-1653**

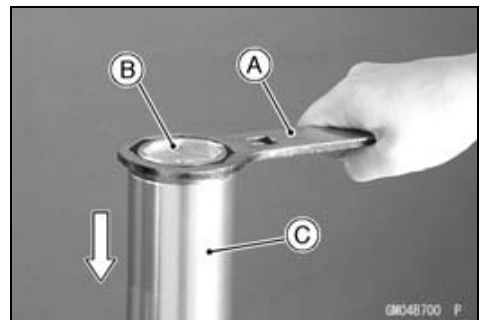

13-30 SUSPENSION

Front Fork (KX450D8F)

- Place a drain pan under the front fork and drain fork oil [A].

NOTE

○ Pump the fork tube several times to discharge the fork oil.

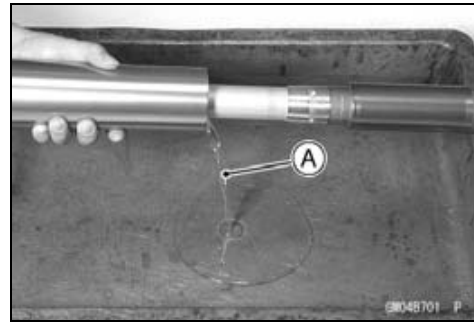

- Raise the outer tube and temporarily install the fork top plug [A] (subtank) to the outer tube [B] with the top plug wrench [C].

Special Tool - Top Plug Wrench, 49 mm: 57001-1653

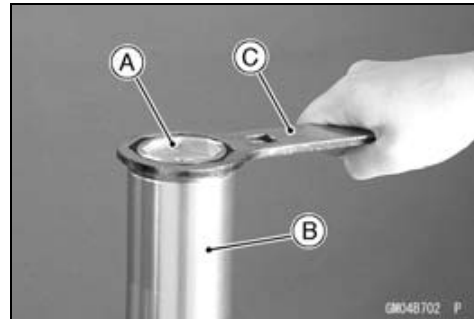

- Hold the axle holder [A] with a vise.
- Protect the axle holder with a rag when using a vise.
- Loosen the adjuster assembly [B] completely.

⚠ WARNING

Clamping the axle holder too tight can damage it which will affect riding stability. Do not clamp the axle holder too tight.

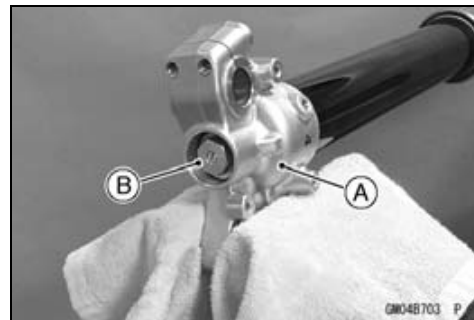

- Compress the outer tube by hands and install the top plug wrench [A] between the axle holder bottom [B] and locknut [C].

Special Tool - Top Plug Wrench, 49 mm: 57001-1653

⚠ WARNING

Be careful of reaction force in spring and fix surely so that the special tool should not come off. Do not place the finger etc. while servicing.

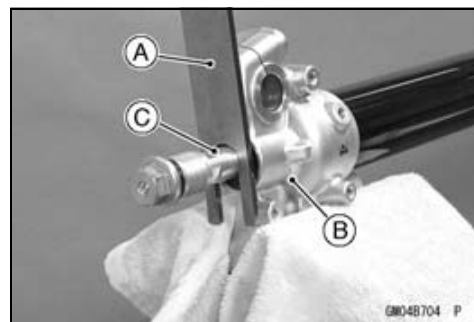

- Hold the locknut [A] with a wrench [B] and remove the adjuster assembly [C].

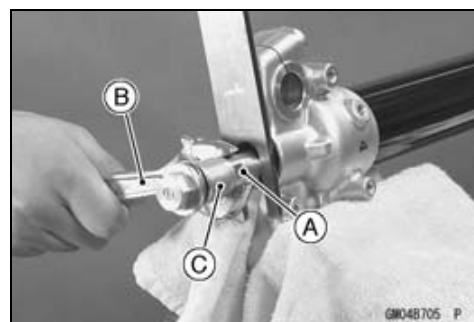

Front Fork (KX450D8F)

- Remove the push rod [A].

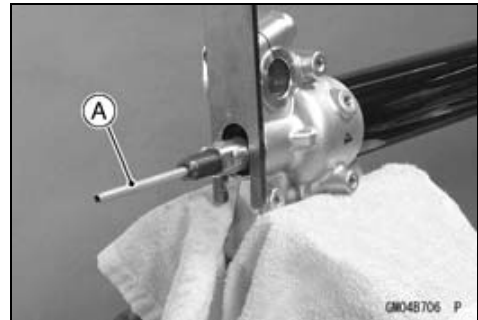

- With the outer tube compressed by hands, remove the top plug wrench [A].

CAUTION
Removing the locknut and pushing the piston rod thread into the cylinder unit will damage the oil seal. Do not remove the locknut from the piston rod.



- Remove the fork leg from the vise.

- Loosen the fork top plug (subtank) [A] with the top plug wrench [B].

Special Tool - Top Plug Wrench, 49 mm: 57001-1653 [B]

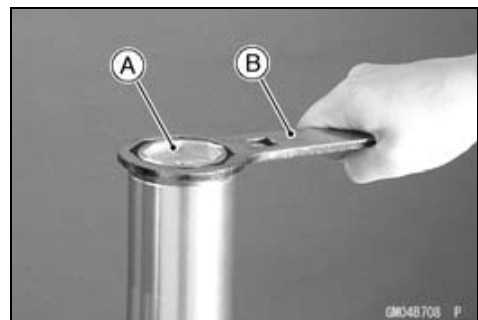

- Remove:
 Cylinder Unit [A]
 Spacer [B]
 Fork Spring [C]

CAUTION
Disassembling the cylinder unit can lead to trouble. Do not disassemble the cylinder unit.

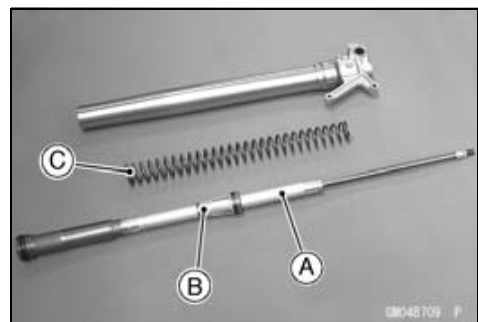

- Remove the dust seal [A] and the retaining ring [B].

CAUTION
Be careful not to scratch the inner tube.

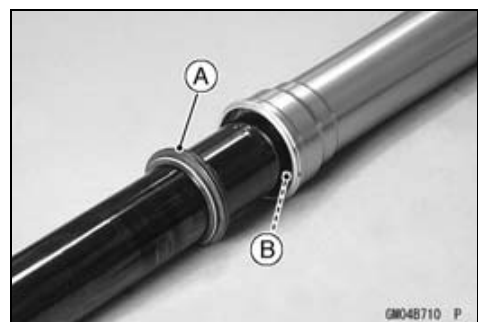

13-32 SUSPENSION

Front Fork (KX450D8F)

- Grasp the outer tube and stroke [A] the inner tube several times. The shock to fork seal separates the inner tube from the outer tube.



- Remove the following parts from the inner tube.

- [A] Guide Bushes
- [B] Washer
- [C] Oil Seal
- [D] Retaining Ring
- [E] Dust Seal

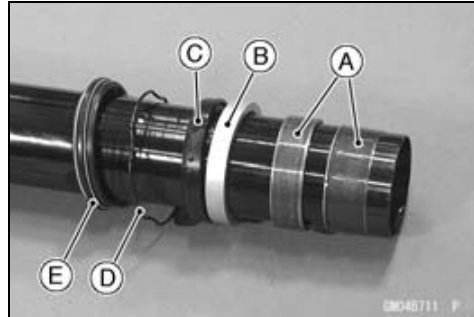

- Holding the top plug wrench (57001-1653) [A] with a vise, loosen the base assembly [B] using the top plug wrench (57001-1653) [C].

Special Tool - Top Plug Wrench, 49 mm: 57001-1653
Top Plug Wrench, 36 mm: 57001-1705

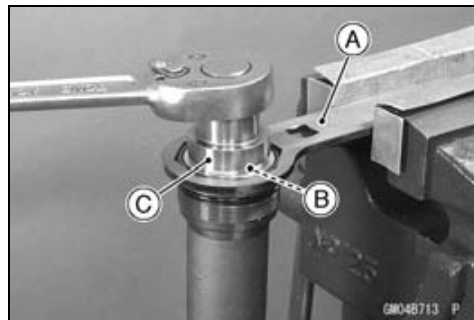

- Remove the base valve assembly [A] from the subtank [B].

NOTE

- Slowly compress the piston rod until it stops so that the base valve assembly can be removed easily.



CAUTION

Disassembling the base valve assembly can lead to trouble.
Do not disassemble the base valve assembly.

- Drain the fork oil [A] from the cylinder unit [B] by pumping the piston rod several times

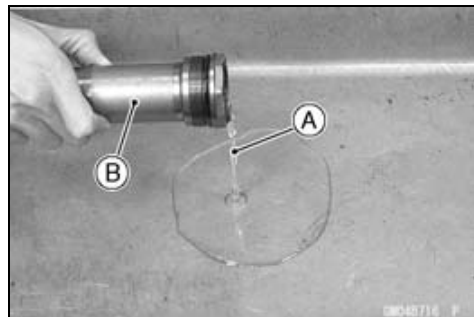

Front Fork (KX450D8F)

Front Fork Assembly

- When the fork tubes are not disassembled, hold the fork inverted position for more than 20 minutes to allow the fork oil to fully drain.

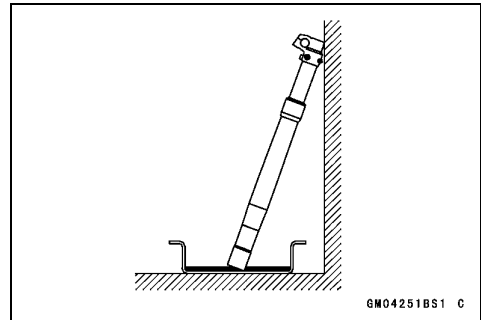

- Replace the following with new ones:
 Dust Seal [A]
 Retaining Ring [B]
 Oil Seal [C]
 Guide Bushes [D]
- Place an oil coated plastic bag [E] over the end of the inner tube to protect the oil seals.
- The inner tube guide bush groove has a sharp edge [F] that cut out the sealing lip of the seals as they are pushed down over the inner tube.
- Install in order these parts on the inner tube.

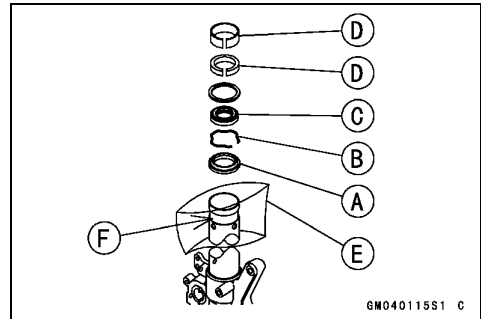

- When assembling the new outer tube guide bush [A], hold the used guide bush [B] against the new one, and tap the used guide bush with the fork oil seal driver [C] until it stops.

Special Tool - Fork Oil Seal Driver, ϕ 48: 57001-1509

- After installing the washer, install the oil seal by using the fork oil seal driver.

Special Tool - Fork Oil Seal Driver, ϕ 48: 57001-1509

- Install the retaining ring to the outer tube.
- Push the dust seal into the outer tube, and put the spring band on the dust seal.

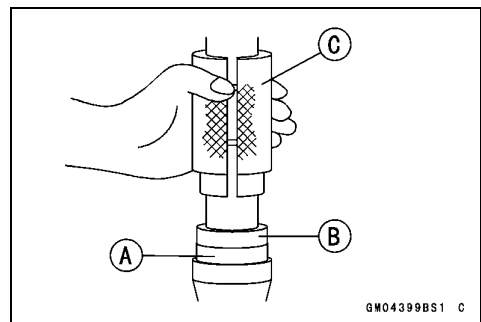

- Clean the threads [A] of subtank and base valve assembly.



13-34 SUSPENSION

Front Fork (KX450D8F)

- With the piston rod in fully compressed position, pour the specified amount of fork oil [A].

Recommended Oil: KHL15-10 (KAYABA01) or equivalent

Recommended Quantity: 191 ml (6.46 US oz)

NOTE

○ Plug the two oil holes on the subtank [B] with fingers.

- Pump [A] the piston rod [B] slowly several times to expel air.

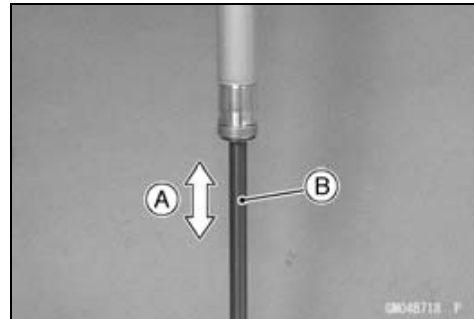
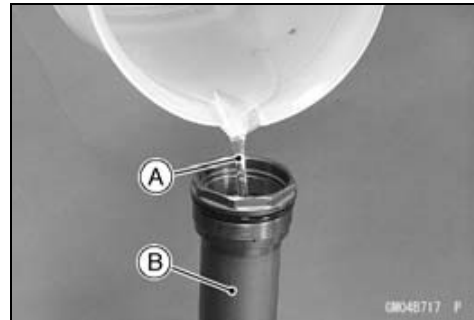

- Replace the O-rings [A] on the base valve assembly with new ones.
- Apply specified fork oil to the O-rings [A] [B] and bushings [C] on the base valve assembly.

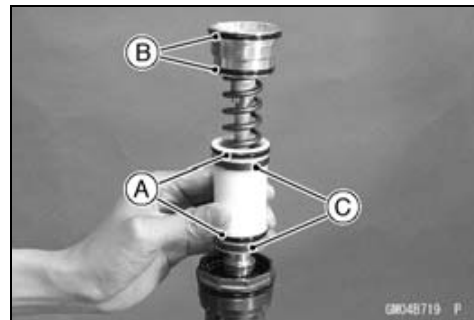

- With the piston rod held immovable in fully compressed position [A], gently install the base valve assembly [B] to the subtank.
- Screw in the base valve assembly in the subtank when the piston rod extends.

NOTE

○ When it is hard to screw in the base valve assembly, pull down the piston rod a little.

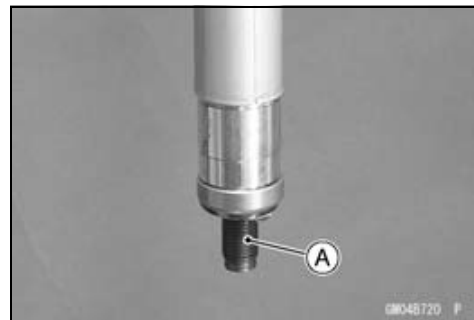

Front Fork (KX450D8F)

- Holding the top plug wrench (57001-1653) [A] with a vise.
- Holding the subtank [B] with the top plug wrench, torque the base valve assembly [C] using the top plug wrench (57001-1705) [D].

Special Tool - Top Plug Wrench, 49 mm: 57001-1653
Top Plug Wrench, 36 mm: 57001-1705

Torque - Base Valve Assembly: 28 N·m (2.9 kgf·m, 21 ft·lb)

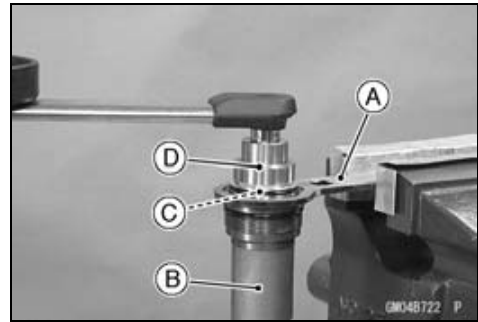

- Protect the piston rod end [A] with a rag [B] to prevent fork damage.
- Discharge the extra oil off the cylinder unit by pumping [C] the piston rod to full stroke.

CAUTION

Be careful not to bend or damage the piston rod when the piston rod is stroked. Service carefully because oil flies out from the oil hole of the cylinder unit.

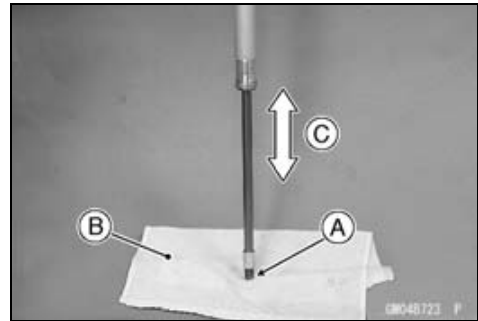

NOTE

- Set the compression damper setting to the softest.
 - Check the piston rod sliding surface for damage.
 - Apply fork oil to the piston rod sliding surface.
- Drain the extra oil from the subtank oil hole [A].

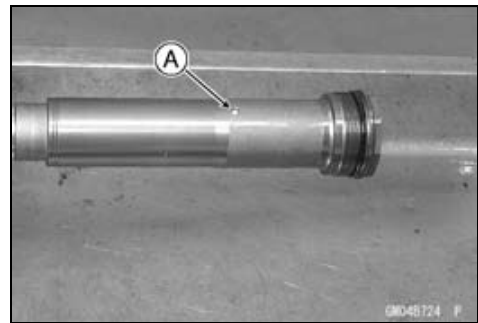

- With the cylinder unit in horizontal position, move [A] the piston rod [B] by hand to inspect it if operating smoothly.
- If the piston rod is not extend, remove the base valve assembly and perform the air bleeding (pour the specified amount fork oil and discharge an excess of oil).

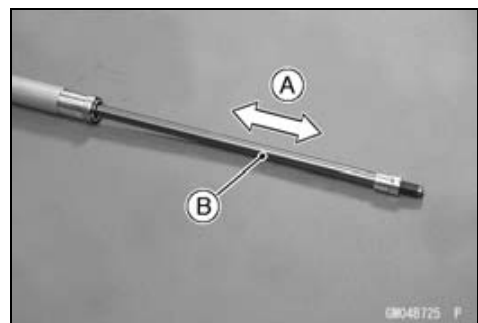

13-36 SUSPENSION

Front Fork (KX450D8F)

- Make sure about 16 mm (0.63 in.) [A] of push rod thread is exposed from the locknut [B].

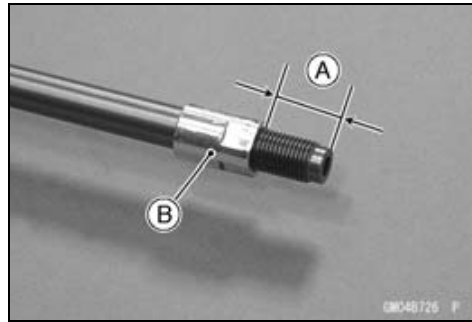

- Completely wipe off the fork oil from the spring [A], collar [B] and cylinder unit [C].
- Insert above-mentioned parts into the fork.

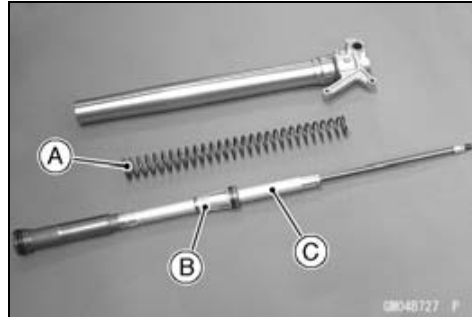

- Temporarily tighten the fork top plug [A] (subtank) using the top plug wrench.

Special Tool - Top Plug Wrench, 49 mm: 57001-1653 [B]

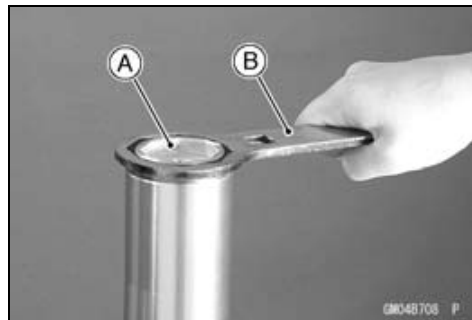

- Clamp the axle holder with a vise.
- Protect the axle holder with a rag when using a vise.

⚠ WARNING

**Clamping the axle holder too tight can damage it which will affect riding stability.
Do not clamp the axle holder too tight.**

- Compress the outer tube by hands and install the top plug wrench [A] between the axle holder bottom and locknut.

Special Tool - Top Plug Wrench, 49 mm: 57001-1653

⚠ WARNING

**Be careful of reaction force in spring and fix surely so that special tool should not come off.
Do not place the fingers etc. while serving.**



Front Fork (KX450D8F)

- Insert the push rod [A] into the piston rod.

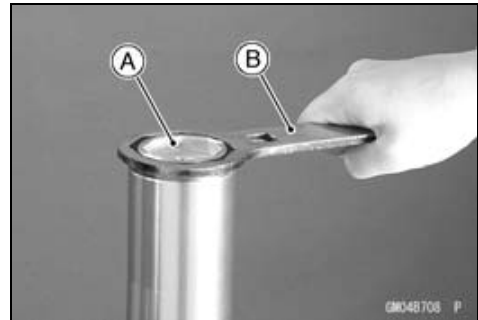

- Replace the O-ring and gasket on the adjuster assembly with new ones and apply specified fork oil to the O-ring.
- Slowly turn the adjuster assembly [A] clockwise until resistance is felt and check the clearance between the locknut [B] and adjuster assembly [A] to provide more than 1 mm (0.04 in.) [C].

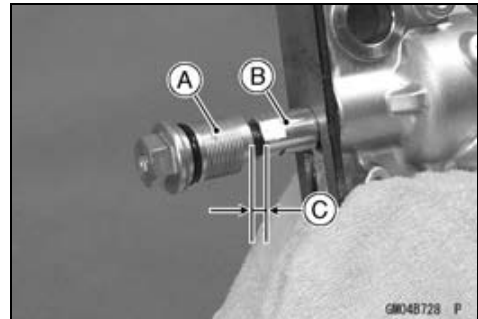

- Turn the locknut [A] counterclockwise until it contacts with the adjuster assembly [B].
- With the locknut held immovable using a wrench, tighten the adjuster assembly to the specified torque.

Torque - Locknut/Adjuster Assembly: 29 N·m (3.0 kgf·m, 21 ft·lb)

- With the outer tube compressed by hands, remove the top plug wrench.

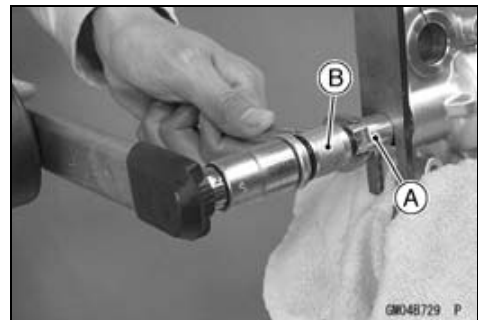

- Apply a non-permanent locking agent to the threads of adjuster assembly.
- Torque the adjuster assembly [A].

Torque - Adjuster Assembly: 58 N·m (5.9 kgf·m, 43 ft·lb)

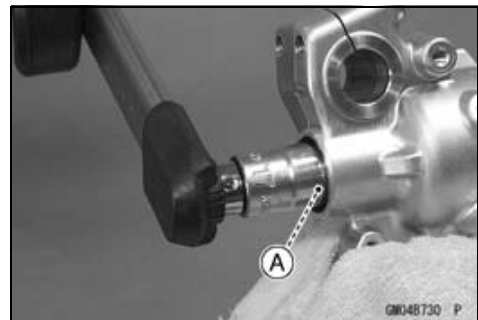

- Loosen and remove the fork top plug (subtank) from the outer tube and slowly slide down the outer tube.

Special Tool - Top Plug Wrench, 49 mm: 57001-1653

- Pour [A] the specified amount of fork oil into the outer tube.

Recommended Oil: KHL15-10 (KAYABA01) or equivalent

Recommended Quantity: 350 mL (11.8 US oz)



13-38 SUSPENSION

Front Fork (KX450D8F)

- Raise the outer tube and temporarily tighten the fork top plug (subtank).

Special Tool - Top Plug Wrench, 49 mm: 57001-1653

- After installing the front fork, torque the top plug [A].

Special Tool - Top Plug Wrench, 49 mm: 57001-1653 [B]



The torque of fork top plug is specified to **30 N·m (3.1 kgf·m, 22 ft·lb)**, however, when you use the top plug wrench (special tool) [A] reduce the torque to 90% of the specified value [**27 N·m (2.8 kgf·m, 20 ft·lb)**] due to the distance [B] between the center of the square hole, where the torque wrench is fitted, and that of the octagonal hole of the wrench.

This torque value [**27 N·m (2.8 kgf·m, 20 ft·lb)**] is applicable when you use a torque wrench whose length gives leverage of approximately 310 mm between the grip point to the center of the coupling square.

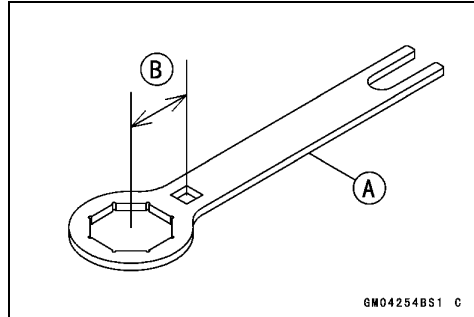

Torque - Front Fork Top Plug: 30 N·m (3.1 kgf·m, 22 ft·lb)

Adjuster Assembly Inspection

- Inspect the adjuster assembly [A] and push rod [B] for damage.
- ★ If they are damaged, replace them with new ones.
- Replace the gasket [C] and O-ring [D] on the adjuster assembly with new ones.

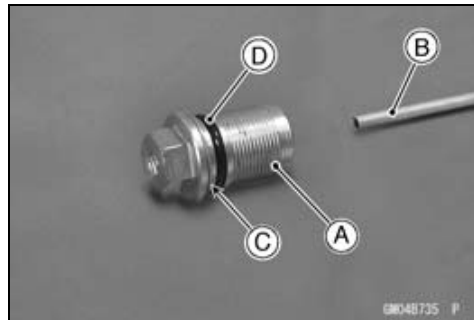

Base Valve Assembly Inspection

- Inspect the threads portion [A], bushing [B], O-ring [C] and spring [D] of base valve assembly [E] for damage.
- ★ If they are damaged, replace base valve assembly with new one.
- Replace the O-rings [F] with new ones.

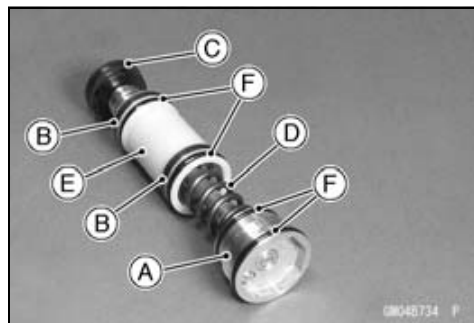

Front Fork (KX450D8F)

Cylinder Unit Inspection

- Inspect the piston rod [B] of cylinder unit [A] for scratches or bending.
- ★ If it has scratches or is bent, replace cylinder unit with a new one.

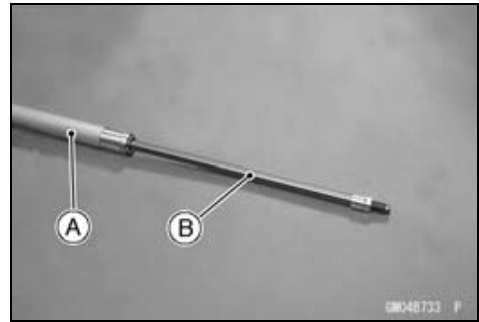

Inner Tube Inspection

- Visually inspect the inner tube [A], repair any damage.
- Nick or rust damage can sometimes be repaired by using a wet-stone to remove sharp edges or raised areas which cause seal damage.
- ★ If the damage is not repairable, replace the inner tube. Since damage to the inner tube damages the oil seal, replace the oil seal whenever the inner tube is repaired or replaced.

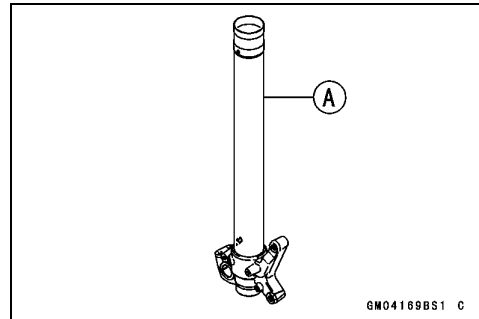

- Temporarily assemble the inner [A] and outer tubes [B], and pump them back and forth manually to check for smooth operation.

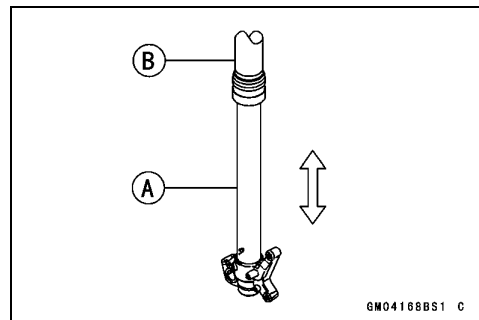

CAUTION

If the inner tube is badly bent or creased, replace it. Excessive bending, followed by subsequent straightening, can weaken the inner tube.

Guide Bush Inspection

- Visually inspect the guide bushes [A], and replace them if necessary.

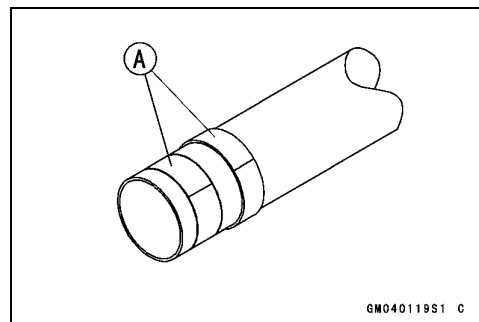

Dust Seal/Oil Seal Inspection

- Inspect the dust seal [A] for any signs of deterioration or damage.
- ★ Replace it if necessary.
- Replace the oil seal [B] with a new one whenever it has been removed.

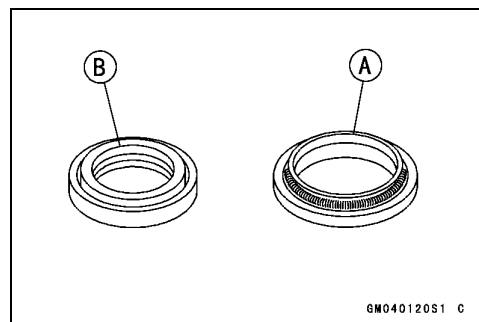

13-40 SUSPENSION

Front Fork (KX450D8F)

Spring Tension Inspection

- Since a spring becomes shorter as it weakens, check its free length [A] to determine its condition.
- ★ If the spring of either fork leg is shorter than the service limit, it must be replaced. If the length of a replacement spring and that of the remaining spring vary greatly, the remaining spring should also be replaced in order to keep the fork legs balanced from motorcycle stability.

Fork Spring Free Length

Standard: 470 mm (18.5 in.)

Service Limit: 461 mm (18.1 in.)

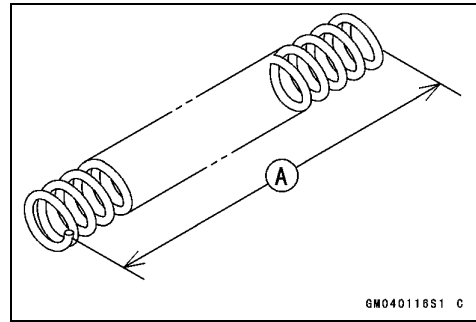

Rear Shock Absorber

To suit to various riding conditions, the spring preload of the shock absorber can be adjusted or the spring can be replaced with an optional one. Also the damping force can be adjusted easily so changing oil viscosity unnecessary.

Rebound Damping Adjustment

- Turn the rebound damping adjuster [A] on the rear shock absorber lower end with the blade of a screwdriver until you feel a click.
- ★ If the damper setting feels too soft or too stiff, adjust it in accordance with the following table:

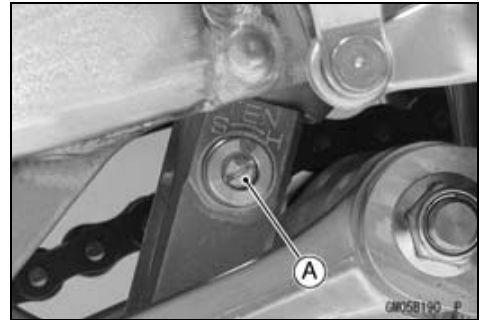

Seated position: adjuster turned fully clockwise [A].

Rebound Damping Adjuster Setting

- Standard:** 11 clicks [B] (KX450D6F)
 8 clicks, (EUR) 10 clicks (KX450D7F)
 8 clicks (KX450D8F)
Softer (Counterclockwise) [C]
Harder (Clockwise) [D]

- *: Number of turns counterclockwise usable range;
 - 16 or more (KX450D6F),
 - 22 clicks or more (KX450D7F ~ D8F)
 Counterclockwise from the fully seated position.

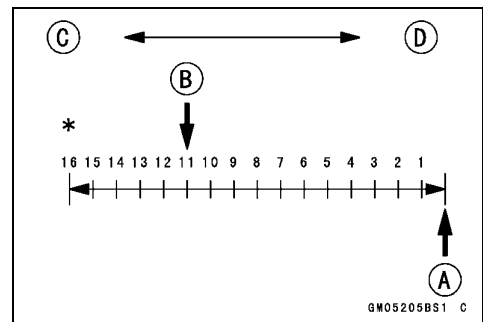

NOTE

- Adjustment of the rebound damping adjuster for the rear suspension will slightly affect the compression damping force. Always make any damping adjustments in small steps and test their effects before using them in competition.

Compression Damping Adjustment

There are two adjustments you can make to the rear shock absorber gas reservoir.

- High Speed Compression Damping Adjuster [A]
- Low Speed Compression Damping Adjuster [B]

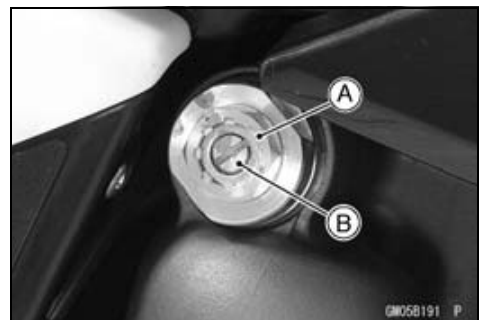

13-42 SUSPENSION

Rear Shock Absorber

- Adjust the high speed compression damping, turn the high speed compression damping adjuster with a 17 mm wrench.
- ★ If the damping feels too soft or too stiff, adjust it in accordance with the following table.

High Speed Compression Damping

- Standard:** 1 1/6 turns out [B] (KX450D6F)
1 1/2 turns out (KX450D7F)
1 turn out (KX450D8F)
Softer (counterclockwise) [C]
Harder (clockwise) [D]

- * : Number of turns counterclockwise usable range;
- 2 turns or more (KX450D6F, D8F)
- 4 turns or more (KX450D7F)
Counterclockwise from the fully seated position.

- Adjust the low speed compression damping, turn the low speed compression damping adjuster with a flat-head screwdriver.
- ★ If the damping feels too soft or too stiff, adjust it in accordance with the following table.

Low Speed Compression Damping

- Standard:** 11 clicks [B] (KX450D6F)
10 clicks (KX450D7F)
8 clicks (KX450D8F)
Softer (counterclockwise) [C]
Harder (clockwise) [D]

- * : Number of turns counterclockwise usable range;
- 16 clicks or more (KX450D6F)
- 19 clicks or more (KX450D7F)
- 22 clicks or more (KX450D8F)
Counterclockwise from the fully seated position.

NOTE

- Adjustment of the rebound damping adjuster for the rear suspension will slightly affect the compression damping force. Always make any damping adjustments in small steps and test their effects before using them in competition.

Spring Preload Adjustment

- Remove:
 - Seat (see Seat Removal in the Frame chapter)
 - Side Covers (see Side Cover Removal in the Frame chapter)
 - Carburetor Holder Clamp Screw (loosen)
 - Muffler (see Muffler Removal in the Engine Top End chapter)
 - Rear Frame Mounting Bolts [A]
 - Rear Frame [B] with Air Cleaner Housing
- Using the jack under the frame, raise the rear wheel off the ground.

Special Tool - Jack: 57001-1238

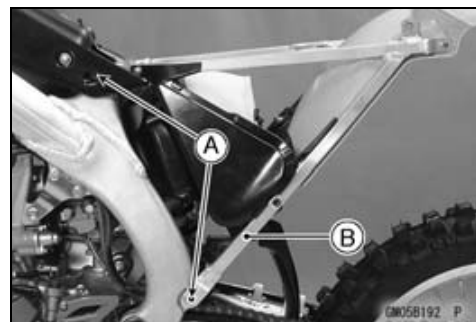
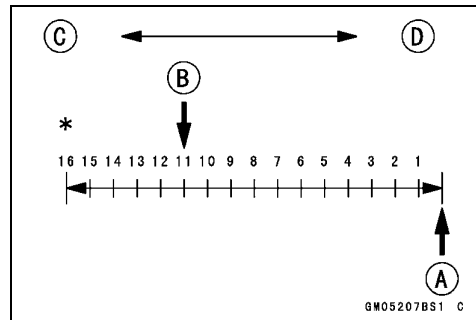
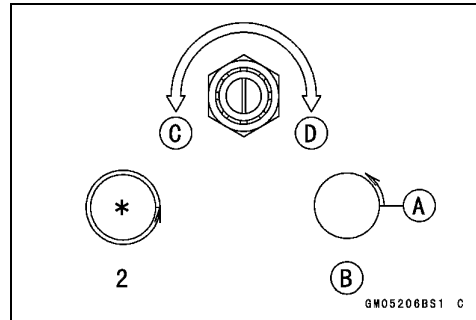

Rear Shock Absorber

- Using the hook wrenches [A], loosen the locknut [B] on the rear shock absorber.

Special Tool - Hook Wrench R37.5, R42: 57001-1101

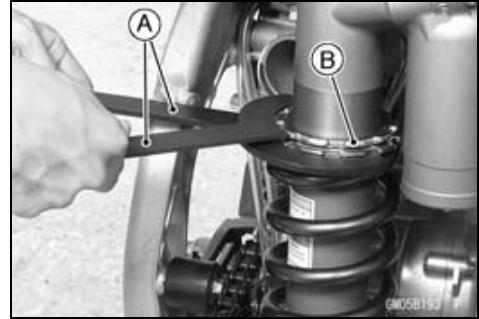

- Using the stem nut wrench [A], turn the adjusting nut [B] as required. Turning the adjusting nut downward marks the spring action harder and upward softer.

Special Tool - Steering Stem Nut Wrench: 57001-1100

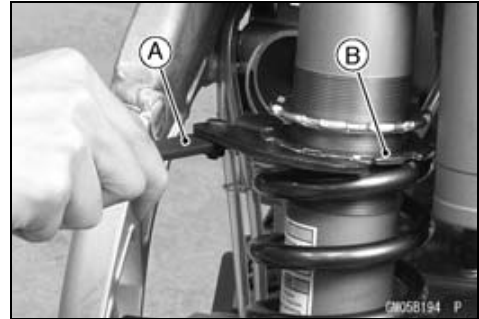

Spring Preload Adjustment

(Adjusting nut position at the lower surface [A] from the center of the mounting hole)

Standard:	127.5 mm (5.020 in.) (KX450D6F ~ D7F)
	128.5 mm (5.059 in.) (KX450D8F)
Adjustable Range	121.5 ~ 138.5 mm (4.783 ~ 5.453 in.) (KX450D6F, D8F)
	122.1 ~ 131.6 mm (4.807 ~ 5.181 in.) (KX450D7F)

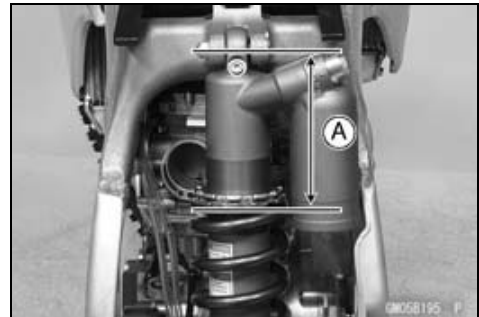

- Tighten the locknut securely.
- After adjusting, move the spring up and down to make sure that the spring is seated.
- Install the parts removed.
- Tighten the rear frame mounting bolts.

Torque - Rear Frame Mounting Bolts: 34 N·m (3.5 kgf·m 25 ft·lb)

Spring Tension Inspection

- Since the spring becomes shorter as it weakens, check its free length [A] to determine its condition.
- ★ If the spring of either rear shock absorber is shorter than the service limit, it must be replaced. If the length of replacement spring and that of the remaining spring vary greatly, the remaining spring should also be replaced in order to keep the rear shock absorbers balanced of motorcycle stability.

Shock Absorber Spring Free Length

Standard:	260 mm (10.2 in.)
Service Limit:	255 mm (10.0 in.)

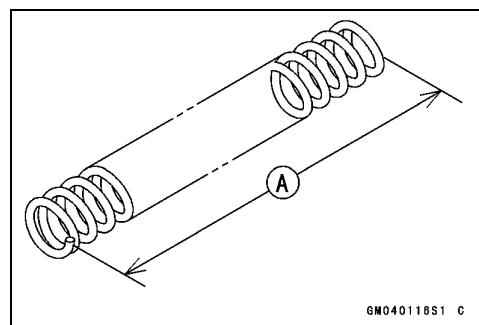

GM040118S1 C

13-44 SUSPENSION

Rear Shock Absorber

Rear Shock Absorber Removal

- Remove:
 - Seat (see Seat Removal in the Frame chapter)
 - Side Covers (see Side Cover Removal in the Frame chapter)
 - Muffler (see Muffler Removal in the Engine Top End chapter)
 - Rear Frame with Air Cleaner Housing
- Using the jack under the frame, raise the rear wheel off the ground.

Special Tool - Jack: 57001-1238

CAUTION

When pulling out the mounting bolts, lift the rear wheel slightly. Forcing or tapping on a bolt could damage the bolt, sleeve, and bearing

- Remove the tie-rod mounting bolt and nut (Front), and turn it downward.
- Remove the rear shock absorber lower mounting bolt [A] and nut.
- Remove the rear shock absorber upper mounting bolt [B], nut, and pull out the rear shock absorber [C] down and out.

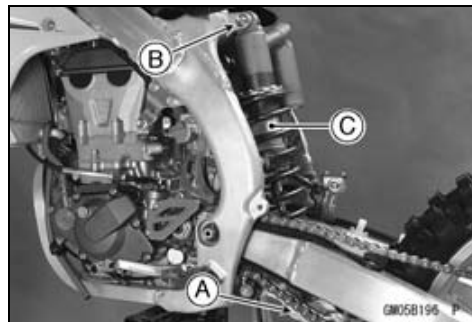

Rear Shock Absorber Installation

- Pack the rocker arm needle bearings with grease.
- Tighten the following:

Torque - Rear Shock Absorber Mounting Nut (Upper): 39 N·m (4.0 kgf·m, 29 ft·lb)

Rear Shock Absorber Mounting Nut (Lower): 34 N·m (3.5 kgf·m, 25 ft·lb)

Rear Frame Mounting Bolts: 34 N·m (3.5 kgf·m, 25 ft·lb)

Tie-Rod Mounting Nut (Front): 83 N·m (8.5 kgf·m, 61 ft·lb) (KX450D6F)

Tie-Rod Mounting Nut (Front): 59 N·m (6.0 kgf·m, 43 ft·lb) (KX450D7F ~)

Spring Replacement

In addition to the standard spring, heavy and light springs are available. If the standard spring is improper for your purpose, select a proper one according to the rider's weight or course conditions.

- Remove the rear shock absorber (see Rear Shock Absorber Removal).
- Clean the threaded portion on the upper of the rear shock absorber.
- Hold the lower of the rear shock absorber with a vise.

Rear Shock Absorber

- Using the hook wrenches [C], loosen the locknut [B] and turn the adjusting nut [A] all way up.

Special Tool - Hook Wrench R37.5, R42: 57001-1101

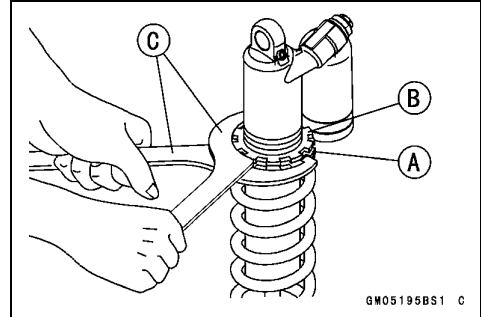

- Remove the rear shock absorber from the vise.
- Slide down the rubber bumper [A].
- Remove the spring guides [B] from the shock absorber and lift off the spring [C].

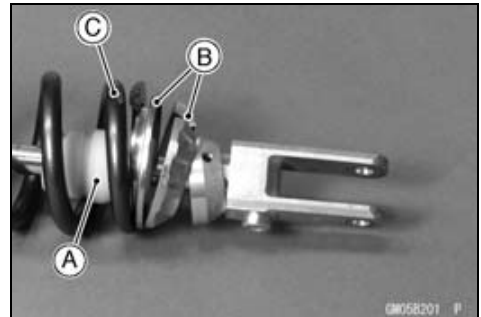

- Exchange the spring for an optional part. Install the spring so that closed coil large diameter end [A] faces upward.
- Install the spring guide.
- Adjust the spring preload (see Spring Preload Adjustment).
- Install the rear shock absorber.
- Install the parts removed.

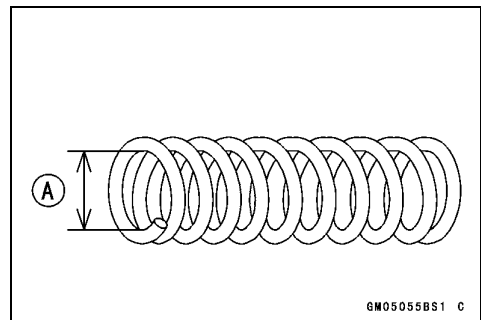

Rear Shock Absorber Disassembly (Oil Change)

- Refer to the Rear Shock Absorber Oil Change in the Periodic Maintenance chapter.

Rear Shock Absorber Assembly

- Refer to the Rear Shock Absorber Oil Change in the Periodic Maintenance chapter.

Rear Shock Absorber Scrapping

⚠ WARNING

Since the reserve tank of the rear shock absorber contains nitrogen gas, do not incinerate the reserve tank without first releasing the gas or it may explode.

- Remove the shock absorber (see Rear Shock Absorber Removal).
- Remove the valve cap [A] and release the nitrogen gas completely from the gas reservoir.
- Remove the valve.

⚠ WARNING

Since the high pressure gas is dangerous, do not point the valve toward your face or body.



13-46 SUSPENSION

Swingarm

Swingarm Removal

- Place the jack [A] under the frame so that the rear wheel is off the ground.

Special Tool - Jack: 57001-1238

- Remove
Rear Wheel (see Rear Wheel Removal in the Wheels/Tires chapter)
Clamps [B]
Brake Pedal [C] (see Brake Pedal Removal in the Brakes chapter)
Disc Protector [D]

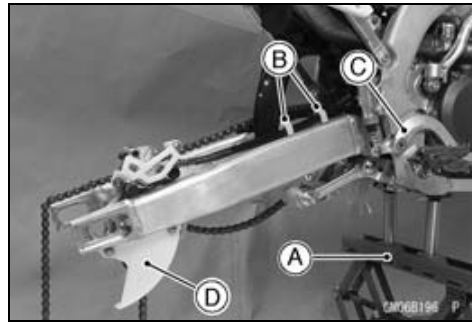

- Remove:
Bolts [A] and Nuts [B]
Chain Guide Plate [C]
Chain Guide [D]

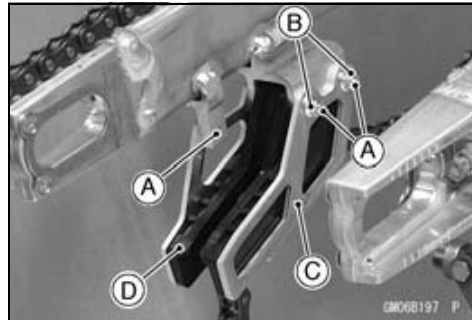

- Unscrew the rocker arm pivot nut [A] and pull out the rocker arm pivot bolt [B].

CAUTION

When pulling out the mounting bolts, lift the swingarm slightly. Forcing or tapping on a bolt could damage the bolt, sleeve, and bearing.

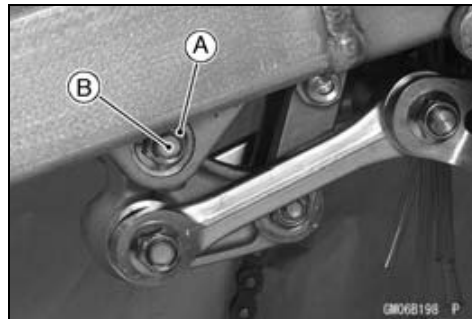

- Unscrew the nut [A].
- Pull out the swingarm pivot shaft [B], and remove the swingarm [C].

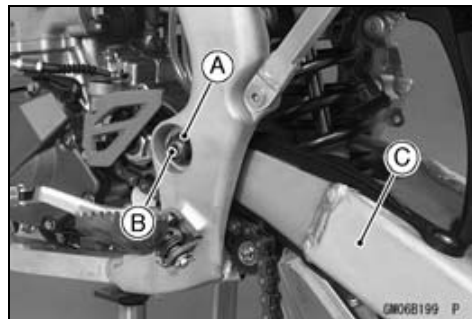

Swingarm

- Unscrew the screws [A]
- Separate the chain slipper [B] from the swingarm.

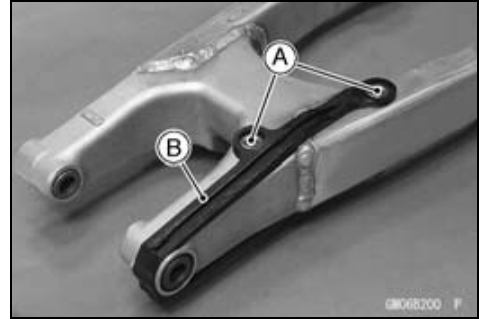

Swingarm Installation

- Apply plenty of grease to the inside of the needle bearings, sleeves, and oil seals.
- Tighten the following:
 - Torque - Swingarm Pivot Shaft Nut: 98 N·m (10 kgf·m, 72 ft·lb)**
 - Rocker Arm Pivot Nut: 83 N·m (8.5 kgf·m, 61 ft·lb) (KX450D6F)**
 - Rocker Arm Pivot Nut: 59 N·m (6.0 kgf·m, 42 ft·lb) (KX450D7F ~)**
- Refer to the Wheels/Tires, Final Drive, and Brakes chapters for wheel installing.

Swingarm Bearing Removal

- Remove:
 - Swingarm (see Swingarm Removal)
 - Collars [A]
 - Grease Seals [B]
 - Sleeves [C]
 - Needle Bearings [D]
- Remove the needle bearings [E] using the oil seal & bearing remover.

Special Tool - Oil Seal & Bearing Remover: 57001-1058

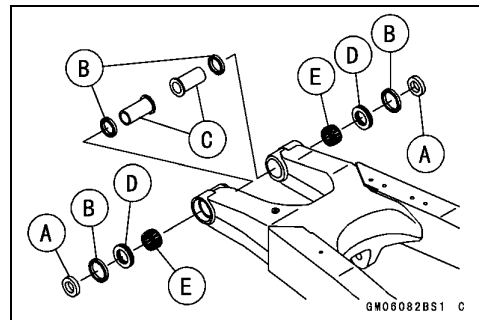

Swingarm Bearing Installation

- Replace the needle bearings and, grease seals with new ones.
- Apply plenty of grease to the sleeves [D], grease seals [C], and needle bearings [A] [B].

NOTE

- Install the needle bearings so that the manufacturer's marks face out.
- Install the grease seals so that the deep groove side of the rip in-ward.

Special Tool - Bearing Driver Set: 57001-1129

- Install the needle bearings and grease seals position as shown.
- The installation procedure is the same as the counter side.

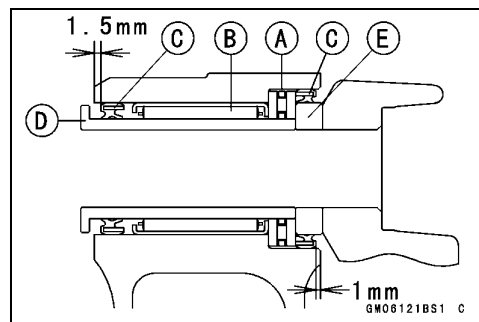

13-48 SUSPENSION

Swingarm

Swingarm Bearing, Sleeve Inspection

CAUTION

Do not remove the bearings for inspection. Removal may damage them.

- Inspect the needle bearings installed in the swingarm.
- The rollers in a bearing normally wear very little, and wear is difficult to measure. Instead of measuring, visually inspect the bearing for abrasion, discoloration, or other damage.
- ★ If the needle bearing, and sleeve show any signs of abnormal wear, discoloration, or damage, replace them as a set.

Drive Chain Guide, Guide Roller, Chain Slipper Wear Inspection

- Visually inspect the drive chain guide [A] and replace it if excessively worn or damaged.
- Visually inspect the upper and lower chain guide rollers [A] and replace them if excessively worn or damaged.
- Visually inspect the chain slipper [A] on the swingarm [B] and replace it if worn or damaged.

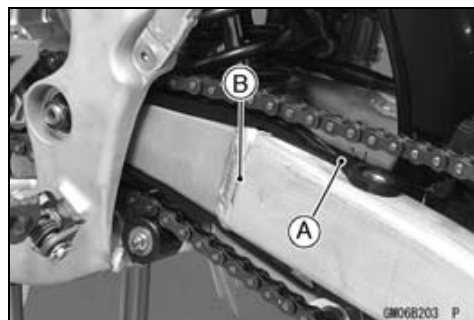
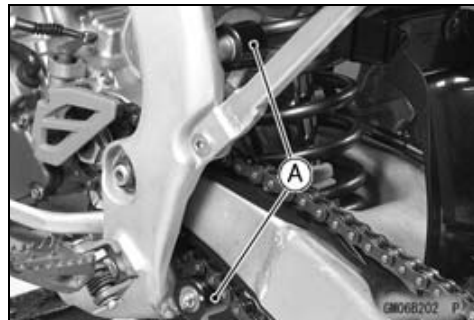
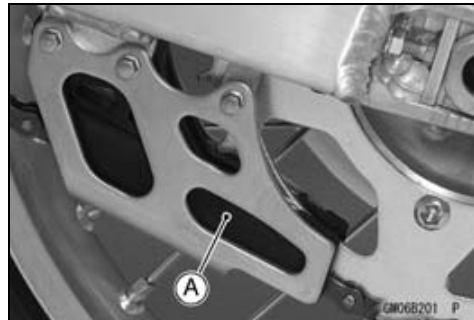

Tie-Rod, Rocker Arm

Tie-Rod Removal

- Using the jack under the frame, raise the rear wheel off the ground.

Special Tool - Jack: 57001-1238

- Unscrew the nut [A] and remove the guide roller [B].

CAUTION

When pulling out the mounting bolts, lift the rear wheel slightly. Forcing or tapping on a bolt could damage the bolt, sleeve, and bearing.

- Remove the tie-rod rear mounting bolt [A].
- Remove the tie-rod front mounting bolt [B], and then take off the tie-rod [C].

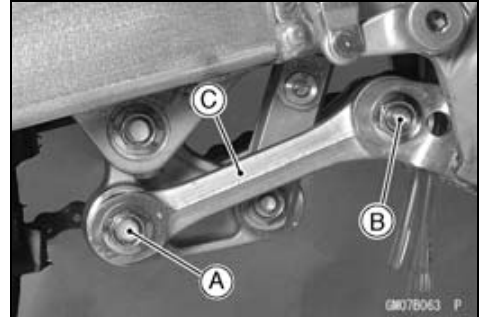
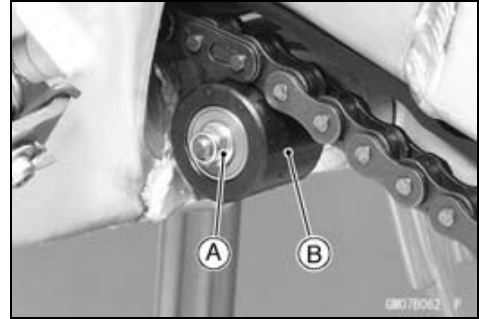

Tie-Rod Installation

- Apply plenty of grease to the inside of the oil seals.
- Tighten the tie-rod front and rear mounting nuts.

Torque - Tie-Rod Mounting Nuts: 83 N·m (8.5 kgf·m, 61 ft·lb) (KX450D6F)

Tie-Rod Mounting Nuts: 59 N·m (6.0 kgf·m, 43 ft·lb) (KX450D7F ~)

Rocker Arm Removal

- Using the jack under the frame, raise the rear wheel off the ground.

Special Tool - Jack: 57001-1238

CAUTION

When pulling out the mounting bolts, lift the rear wheel slightly. Forcing or tapping on bolt could damage the bolt, sleeve, and bearing.

- Remove the rear shock absorber lower mounting bolt [A].
- Remove the tie-rod rear mounting bolt [B].
- Remove the rocker arm pivot bolt [C].
- Remove the rocker arm [D].

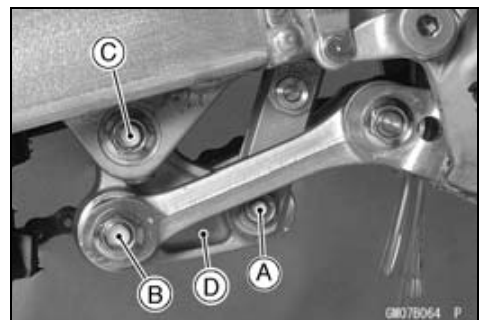

13-50 SUSPENSION

Tie-Rod, Rocker Arm

Rocker Arm Installation

- Apply plenty of grease to the inside of the rocker arm, needle bearings, oil seals and grease seals outside of the sleeve.
- Tighten:
 - Torque - Rear Shock Absorber Mounting Nut (Lower): 34 N·m (3.5 kgf·m, 25 ft·lb)**
 - Rocker Arm Pivot Nut: 83 N·m (8.5 kgf·m, 61 ft·lb) (KX450D6F)**
 - Rocker Arm Pivot Nut: 59 N·m (6.0 kgf·m, 43 ft·lb) (KX450D7F ~)**
 - Tie-Rod Mounting Nuts: 83 N·m (8.5 kgf·m, 61 ft·lb) (KX450D6F)**
 - Tie-Rod Mounting Nuts: 59 N·m (6.0 kgf·m, 43 ft·lb) (KX450D7F ~)**

Tie-Rod and Rocker Arm Bearing Removal

- Remove:
 - Tie-Rod (see Tie-Rod Removal)
 - Rocker Arm (see Rocker Arm Removal)
 - Collars [A]
 - Sleeves [B]
 - Oil Seals [C]
 - Grease Seals [D]
 - Remove the needle bearings [E], using the bearing remover head and bearing remover shaft.
 - Remove the needle bearing [F], using the oil seal & bearing remover.
- Special Tools - Bearing Remover Head: 57001-1267**
Bearing Remover Shaft: 57001-1265
Oil Seal & Bearing Remover: 57001-1058

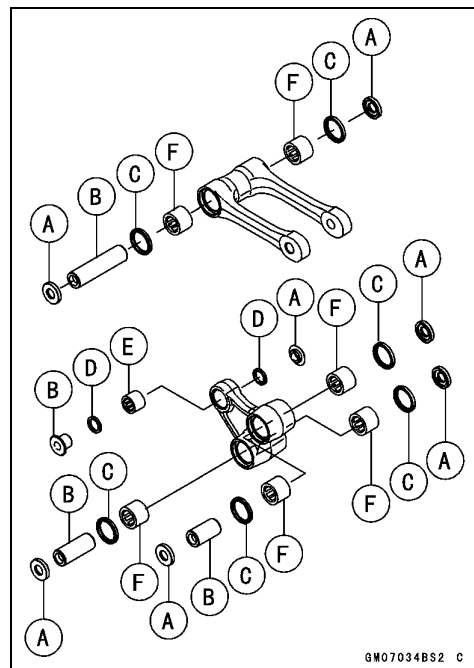

Tie-Rod, Rocker Arm

Tie-Rod and Rocker Arm Bearing Installation

- Replace the needle bearing, grease seals and oil seals with new ones.
- Apply plenty of grease to the oil seal and needle bearings [A].

NOTE

○ Install the grease seals so that the deep groove side of the lip out-ward.

- Install the needle bearings [A], [B] and grease seals [C] position as shown.
- The installation procedure is the same as the counter side.

- 1 mm (0.04 in.) [D] Rear Shock Absorber [G]
- 4.5 mm (0.18 in.) [E] Tie-rod [H]
- 4.25 mm (0.167 in.) [F] Rocker Arm [I]

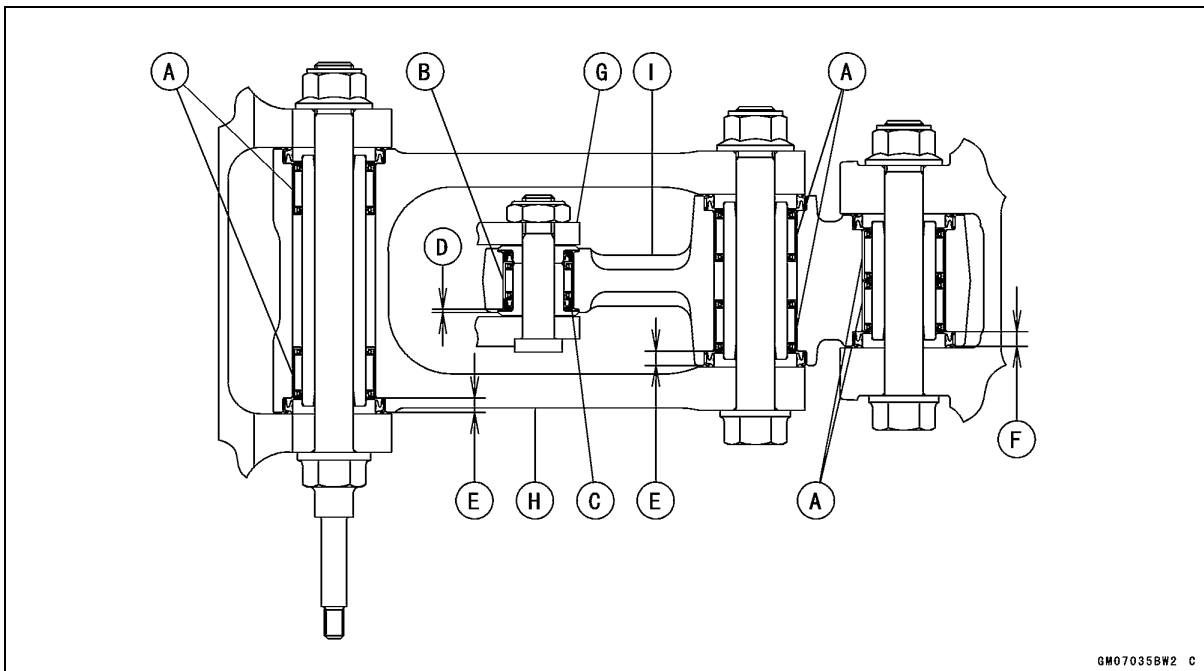

Needle Bearing Inspection

- ★ If there is any doubt as to the condition of either needle bearing, replace the bearing and sleeve as a set.

13-52 SUSPENSION

Uni-Trak Maintenance

Uni-Trak Linkage Inspection

- Refer to the Uni-Trak Linkage Inspection in the Periodic Maintenance chapter.

Tie-Rod and Rocker Arm Sleeve Wear Inspection

- Pull out the sleeves [A] of the tie-rod and rocker arm.
- Measure the outside diameter of the sleeve.
- ★ If the sleeve is worn past the service limit, replace the sleeve.

Sleeve Outside Diameter

Standard:

Tie-rod 19.987 ~ 20.000 mm (0.7888 ~ 0.78740 in.)

Rocker Arm:

[Large] 19.987 ~ 20.000 mm (0.78688 ~ 0.78740 in.)

[Small] 15.950 ~ 16.000 mm (0.62795 ~ 0.62992 in.)

Service Limit:

Tie-rod 19.85 mm (0.781 in.)

Rocker Arm:

[Large] 19.85 mm (0.781 in.)

[Small] 15.92 mm (0.627 in.)

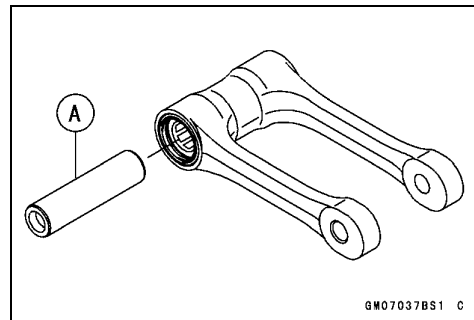
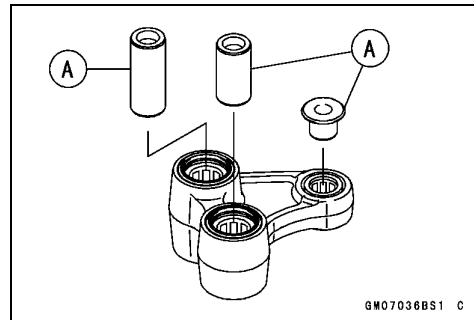

Tie-Rod and Rocker Arm Mounting Bolt Bend Inspection

A bent bolt causes vibration, poor handling, and instability.

- To measure the bolt runout, remove the bolt, place it in V blocks, and set a dial gauge to the bolt at a point halfway between the blocks. Turn [A] the bolt to measure the runout. The amount of dial variation is the amount of runout.
- ★ If runout exceeds the service limit, replace the bolt.

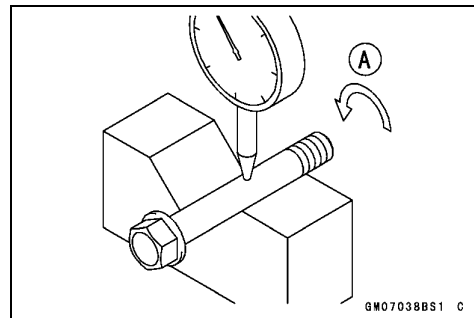

Bolt Runout

Standard: TIR 0.1 mm (0.004 in.) or less

Service Limit: TIR 0.2 mm (0.008 in.)

Steering

Table of Contents

Exploded View	14-2
Special Tools	14-4
Steering	14-5
Steering Inspection	14-5
Steering Adjustment.....	14-5
Steering Stem, Stem Bearing Removal	14-5
Steering Stem, Stem Bearing Installation	14-7
Stem Bearing Lubrication.....	14-8
Stem Bearing Wear, Damage Inspection.....	14-8
Stem Warp Inspection.....	14-8
Handlebar	14-9
Handlebar Removal	14-9
Handlebar Installation	14-9

Exploded View

No.	Fastener	Torque			Remarks
		N·m	kgf·m	ft·lb	
1	Handlebar Holder Bolts	25	2.5	18	2T
2	Steering Stem Head Nut	98	10	72	
3	Steering Stem Nut	4.9	0.50	43 in·lb	T
4	Front Fork Clamp Bolts (Upper)	20	2.0	15	AL
5	Front Fork Clamp Bolts (Lower)	20	2.0	15	AL

6. Handlebar Holder (Upper)

7. Handlebar

8. Handlebar Holder (Lower)

9. Steering Stem Head Bracket

10. Upper Tapered Roller Bearing

11. Head Pipe

12. Lower Tapered Roller Bearing

13. Steering Stem

AD: Apply adhesive cement.

AL: Tighten the two clamp bolts alternately two times to ensure even tightening torque.

G: Apply grease.

O: Apply 2-stroke oil.

T: First, tighten the stem locknut with 39 N·m (4.0 kgf·m, 29 ft·lb) of torque, then loosen it and retighten it with 4.9 N·m (0.50 kgf·m, 43 in·lb) of torque.

14-4 STEERING

Special Tools

Bearing Puller:
57001-135

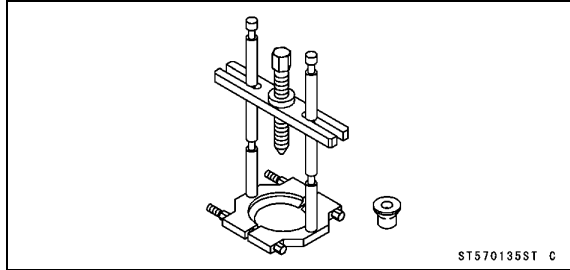

Head Pipe Outer Race Driver, $\phi 54.5$:
57001-1077

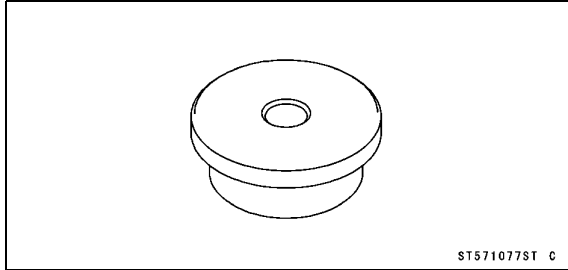

Steering Stem Bearing Driver:
57001-137

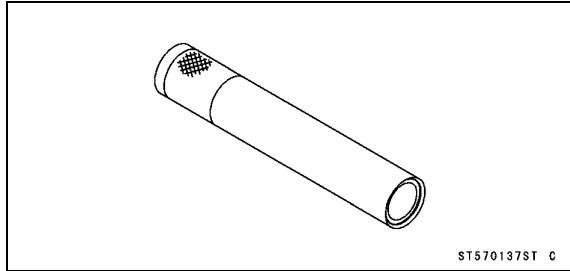

Steering Stem Nut Wrench:
57001-1100

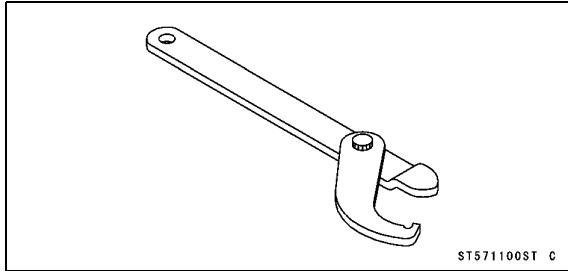

Steering Stem Bearing Driver Adapter, $\phi 34.5$:
57001-1074

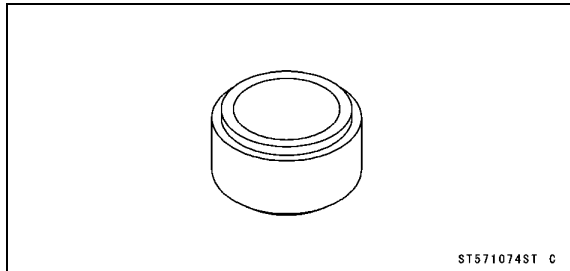

Head Pipe Outer Race Remover ID > 37 mm:
57001-1107

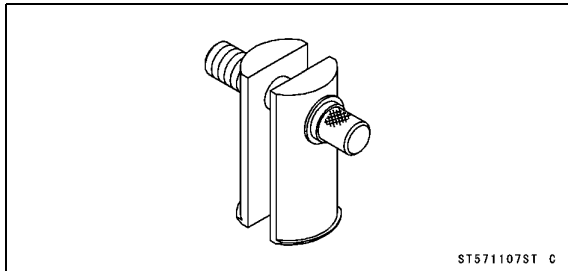

Head Pipe Outer Race Press Shaft:
57001-1075

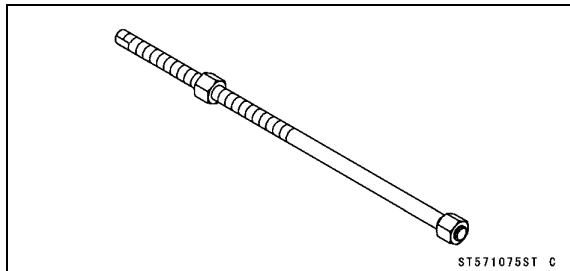

Jack:
57001-1238

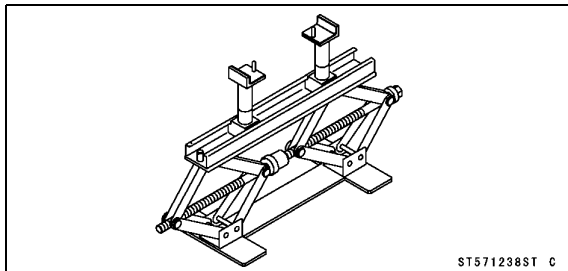

Head Pipe Outer Race Driver, $\phi 51.5$:
57001-1076

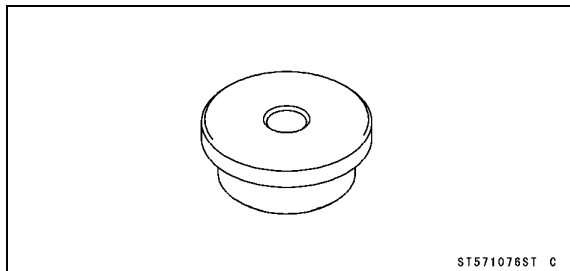

Bearing Puller:
57001-1575

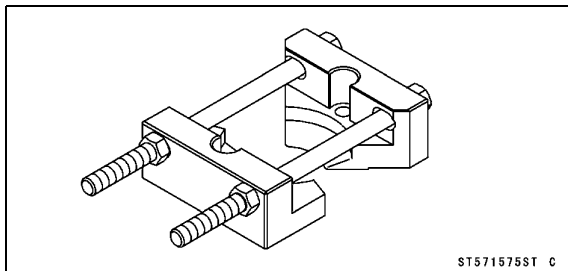

Steering

Steering Inspection

- Refer to the Steering Inspection in the Periodic Maintenance chapter.

Steering Adjustment

- Refer to the Steering Adjustment in the Periodic Maintenance chapter.

Steering Stem, Stem Bearing Removal

- Remove:
 - Front Wheel (see Front Wheel Removal in the Wheels/Tires chapter)
 - Front Fender Bolts [A]
 - Front Fender [B]

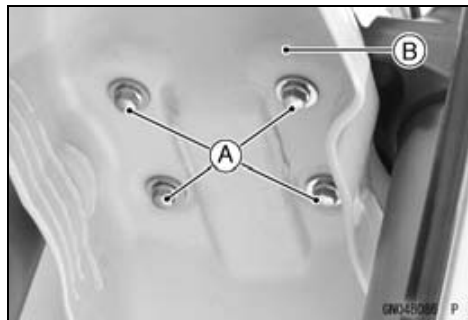

- Remove:
 - Handlebar Pad [A]
 - Number Plate [B]
 - Breather Hose [C] (Pull out)

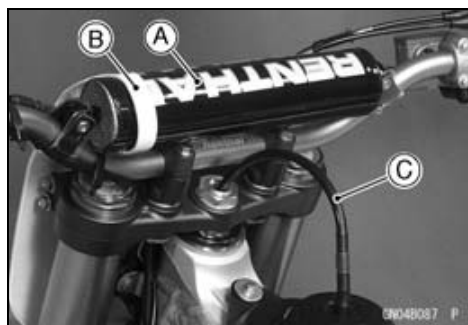

- Remove the bolts [A] to remove the brake hose [C] from the holder [B].

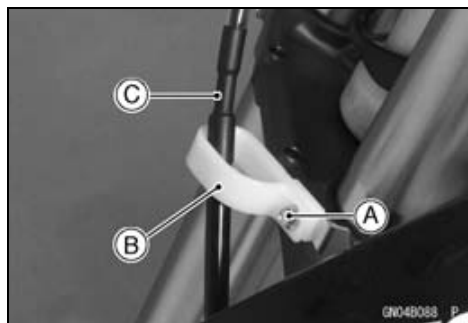

- Remove:
 - Handlebar Holder Bolts [A]
 - Handlebar Holder (Upper) [B]
 - Handlebar [C] (see Handlebar Removal)
- Remove the front fork upper clamp bolts [D]
- Remove the steering stem head nut [E] and washer.
- Remove the steering stem head [F].

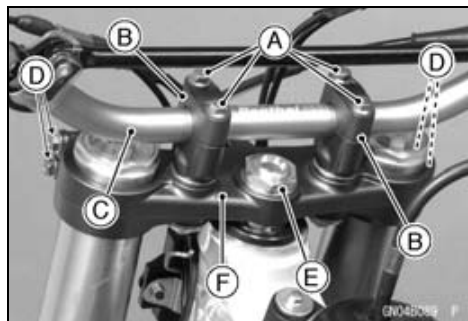

14-6 STEERING

Steering

- Remove:
 - Front Fork Lower Clamp Bolts [A]
 - Front Fork [B]

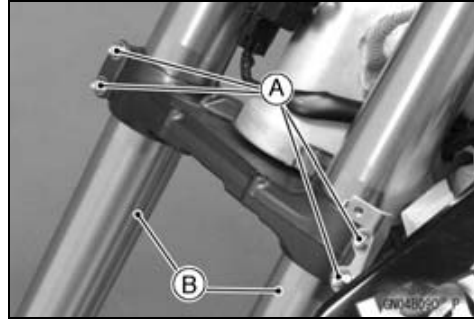

- Pushing up on the stem base [A], and remove the steering stem nut [B], with the steering stem nut wrench [C], then remove the steering stem [D] and stem base.

Special Tool - Steering Stem Nut Wrench: 57001-1100

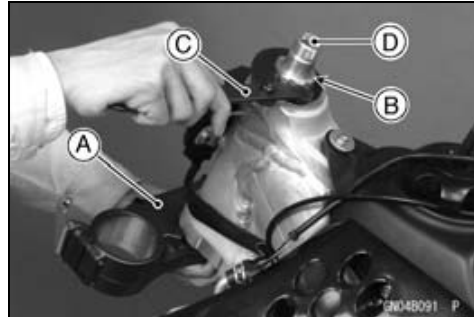

- Take off the upper stem bearing inner race (tapered roller bearing) [A].

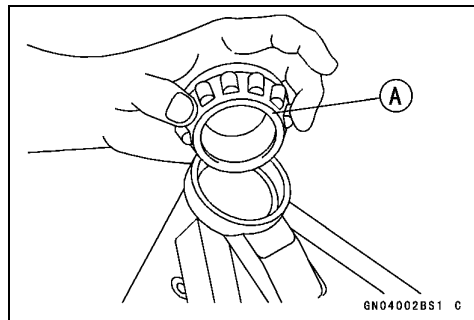

- Drive out the bearing outer races from the head pipe.
- Remove the outer races pressed into the head pipe, using the head pipe outer race remover [A], and hammer the head pipe outer race remover to drive it out.

Special Tool - Head Pipe Outer Race Remover ID > 37 mm: 57001-1107

NOTE

○ If either steering stem bearing is damaged, it is recommended that both the upper and lower bearing (including outer races) should be replaced with new ones.

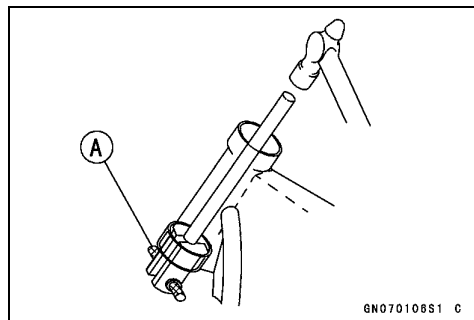

- Remove the lower stem bearing inner race (tapered roller bearing) [A] with its grease seal from the stem using bearing puller.

Special Tools - Bearing Puller: 57001-1575
Bearing Puller: 57001-135

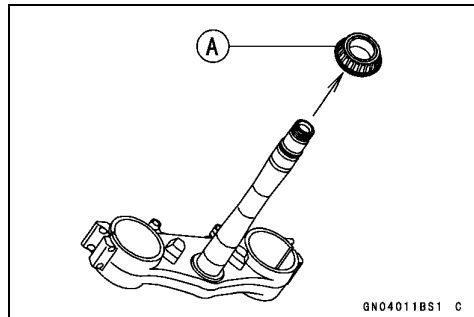

Steering

Steering Stem, Stem Bearing Installation

- Replace the bearing outer race with new ones.
- Apply grease to the outer races, and drive them into the head pipe at the same time using the head pipe outer race press shaft [A] and the head pipe outer race drivers.

Special Tools - Head Pipe Outer Race Press Shaft: 57001-1075
Head Pipe Outer Race Driver, ϕ 54.5: 57001-1077 [B]
Head Pipe Outer Race Driver, ϕ 51.5: 57001-1076 [C]

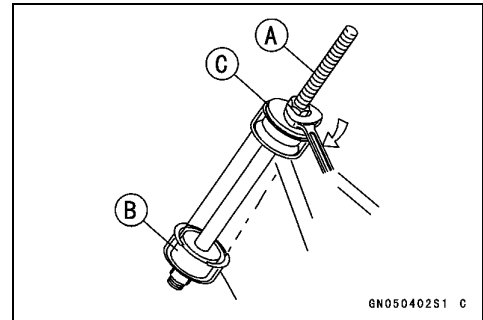

- Replace the lower inner races with new ones.
- Apply grease to the lower tapered roller bearing [A], and drive it onto the stem using the steering stem bearing driver [B] and adapter [C].

Special Tools - Steering Stem Bearing Driver: 57001-137
Steering Stem Bearing Driver Adapter, ϕ 34.5: 57001-1074

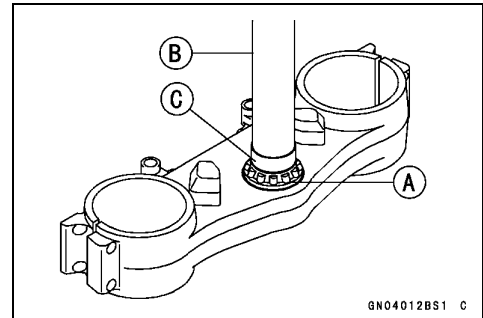

- Apply grease to the upper inner race, and install it in the head pipe.
- Install the stem through the head pipe and upper bearing, install the stem cap and hand-tighten the stem nut while pushing up on the stem base.
- Install the stem head and washer, and tighten the stem head nut lightly.
- Settle the bearing in place as follows;
 - Tighten the stem nut to 39 N·m (4.0 kgf·m, 29 ft·lb) of torque. (To tighten the steering stem nut to the specified torque, hook the wrench [A] on the stem nut, and pull the wrench at the hole by 22.2 kg force [B] in the direction shown.)

Special Tool - Steering Stem Nut Wrench: 57001-1100

- Check that there is no play and the steering stem turns smoothly without rattles. If not, the steering stem bearings may be damaged.
- Again back out the stem nut a fraction of a turn until it turns lightly.
- Turn the stem nut lightly clockwise until it just becomes hard to turn. Do not overtighten, or the steering will be too tight.

Torque - Steering Stem Nut: 4.9 N·m (0.50 kgf·m, 43 in·lb)

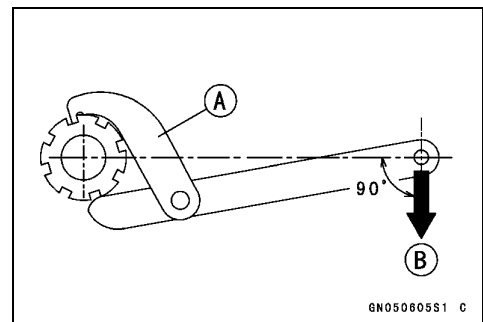

14-8 STEERING

Steering

- Install the front fork (see Front Fork Installation in the Suspension chapter).

NOTE

○ Tighten the fork upper clamp bolts first, next the stem head nut, last the fork lower clamp bolt.

- Tighten:

Torque - Steering Stem Head Nut: 98 N·m (10 kgf·m, 72 ft·lb)

Front Fork Clamp Bolts (Upper): 20 N·m (2.0 kgf·m, 15 ft·lb)

Front Fork Clamp Bolts (Lower): 20 N·m (2.0 kgf·m, 15 ft·lb)

NOTE

○ Tighten the two clamp bolts alternately two times to ensure even tightening torque.

- Install the parts removed (see the appropriate chapter).

⚠ WARNING

Do not impede the handlebar turning by routing the cables, wires, and hoses improperly (see the Appendix chapter).

- Check and Adjust:
 - Steering
 - Front Brake
 - Clutch Cable
 - Throttle Cable

Stem Bearing Lubrication

- Refer to the Stem Bearing Lubrication in the Periodic Maintenance chapter.

Stem Bearing Wear, Damage Inspection

- Using a high-flash point solvent, wash the upper and lower tapered rollers in the cages, and wipe the upper and lower outer races, which are press-fitted into the frame head pipe, clean off grease and dirt.
- Visually check the outer race and the rollers.
- ★ Replace the bearing assembly if it show damage.

Stem Warp Inspection

- Whenever the steering stem is removed, or if the steering cannot be adjusted for smooth action, check the steering stem for straightness.
- ★ If the steering stem shaft is bent [A], replace the steering stem.

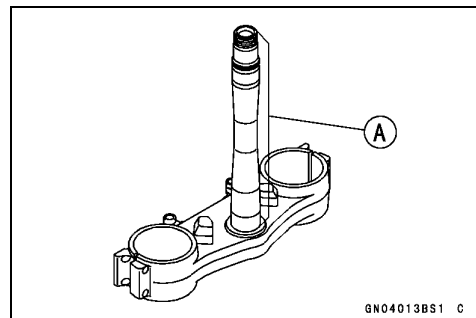

GN04013BS1 C

Handlebar

Handlebar Removal

- Remove:
 - Number Plate [A]
 - Clutch Holder [B]
 - Engine Stop Switch [C]
 - Clamps [D]
 - Left Handlebar Grip [E]

- Remove:
 - Throttle Grip Assy [A] (see Throttle Cable Replacement in the Fuel System chapter)
 - Master Cylinder [B] (see Front Master Cylinder Removal in the Brakes chapter)

- Remove:
 - Handlebar Holder Bolts [A]
 - Handlebar Holder (Upper)[B]
 - Handlebar [C]

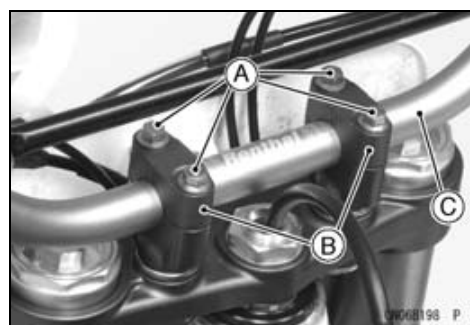
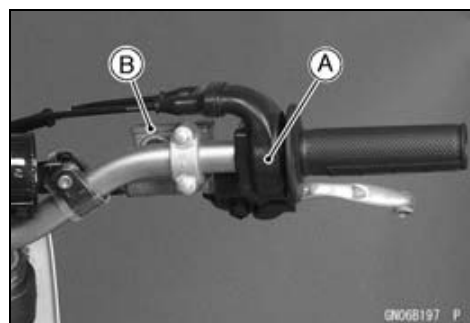
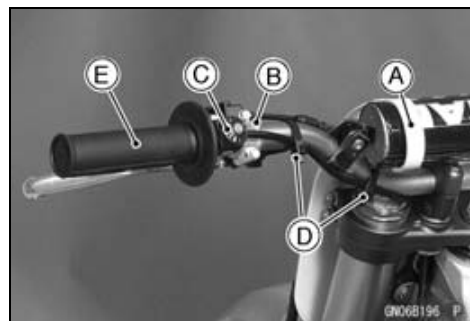

Handlebar Installation

- Apply adhesive cement to the inside of the left handlebar grip.
 - Install the left handlebar grip so that the arrow [A] on the grip face to the forward.
-
- Install the clutch lever [A] so that it incline $20^{\circ} \pm 5^{\circ}$ [B] more than the horizontal line [C] and position it from the edge of the grip to 170 mm (6.69 in.) [D].

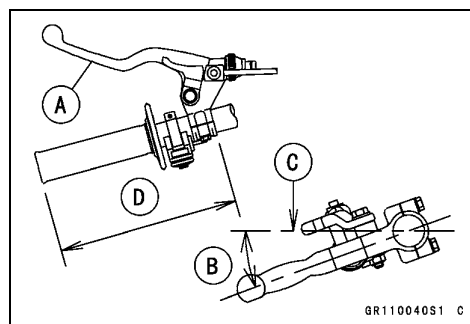
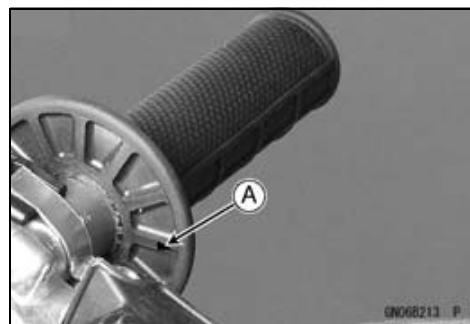

14-10 STEERING

Handlebar

- Apply grease to the throttle cable upper end and clutch cable upper end.
- Apply a 2-stroke oil to the throttle grip inner wall [A].

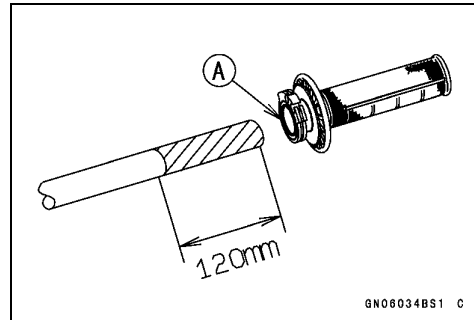

- Install the throttle grip assy so that the grip [A] is in as far as it will go.
- Position the throttle grip assy so that the parting line [B] of the throttle case vertically, and tighten the screws.
- Install the front master cylinder (see Front Master Cylinder Installation in the Brakes chapter).

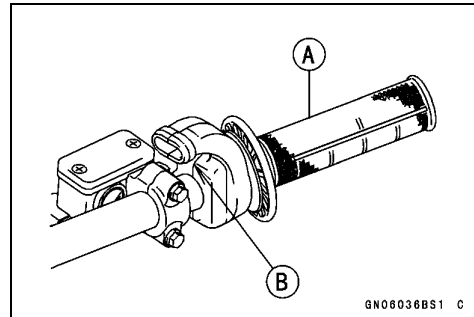

- Install the handlebar [B] on the handlebar holder (lower) so that the protruded scales of the both side adjust to the same width [A].
- Apply 2-stroke oil to the thread of the handlebar holder bolts.
- Install the handlebar holder (upper) so that center [D] of the handlebar holder (upper) [C] and handlebar bridge [E] align.

Torque - Handlebar Holder Bolts: 25 N·m (2.5 kgf·m, 18 ft·lb)

Front [F]

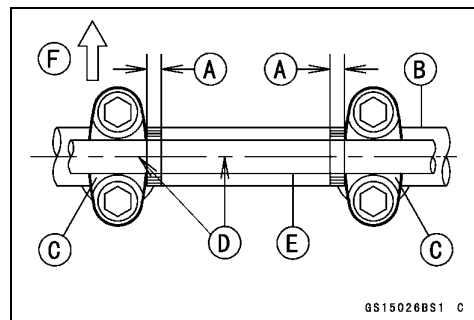

- After tighten, make sure the gap [A] [B] of the front and rear are same width.

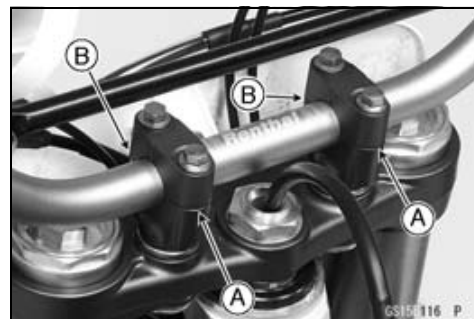

Frame

Table of Contents

Exploded View	15-2
Frame	15-4
Frame Inspection	15-4
Rear Frame Removal.....	15-4
Rear Frame Installation.....	15-4
Engine Guard Installation.....	15-5
Seat	15-6
Seat Removal	15-6
Seat Installation	15-6
Side Cover.....	15-7
Side Cover Removal	15-7
Side Cover Installation	15-7
Fender	15-8
Front Fender Removal	15-8
Rear Fender Removal.....	15-8
Rear Flap Removal	15-8

15-2 FRAME

Exploded View

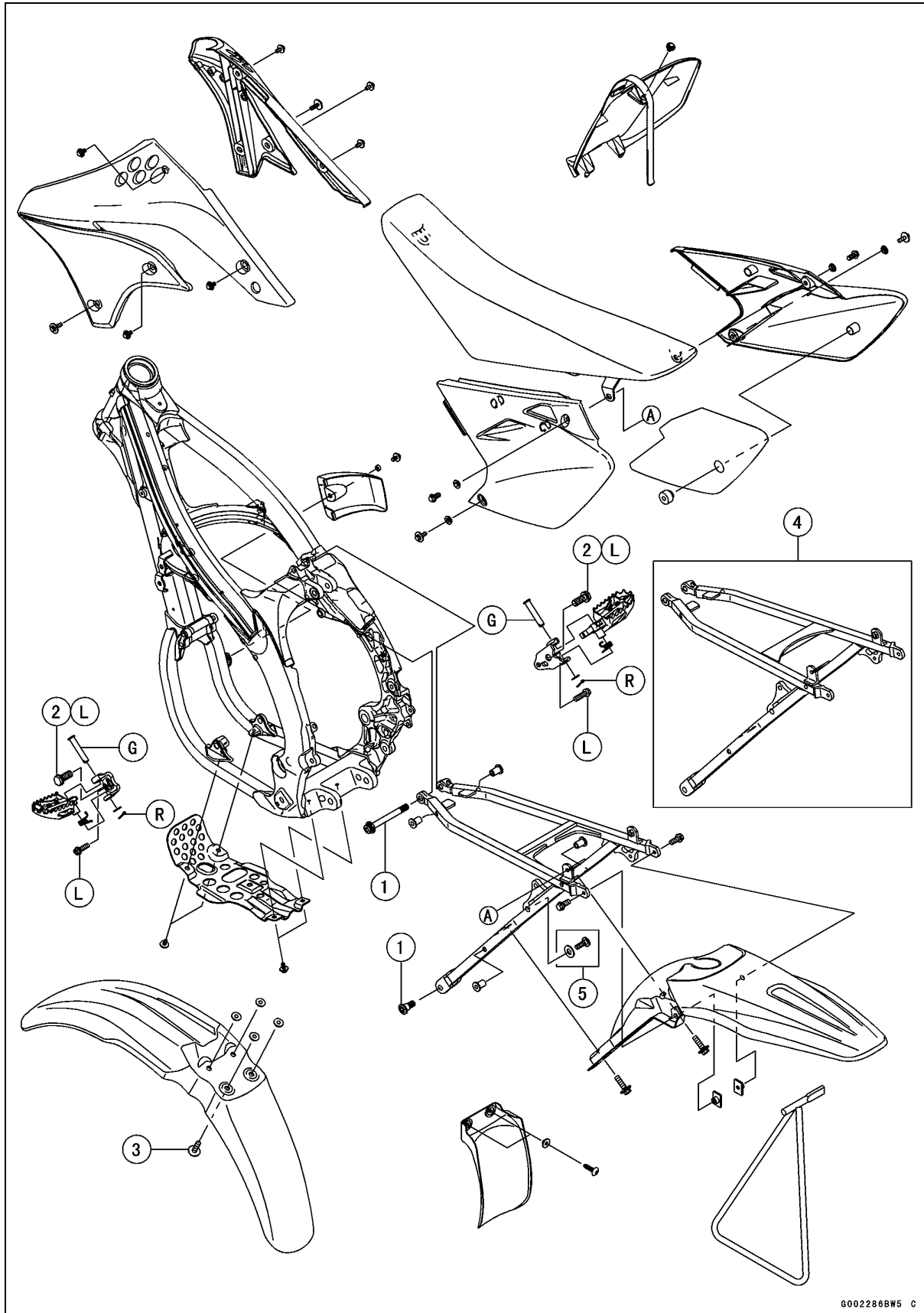

G002286BWS C

Exploded View

No.	Fastener	Torque			Remarks
		N·m	kgf·m	ft·lb	
1	Rear Frame Mounting Bolt	34	3.5	25	
2	Upper Footpeg Bracket Bolts	54	5.5	40	L

3. Front Fender Bolts

4. KX450D6F ~ D7F

4. KX450D8F

G: Apply grease.

L: Apply a non-permanent locking agent.

R: Replacement Parts

15-4 FRAME

Frame

Frame Inspection

- Refer to the Frame Inspection in the Periodic Maintenance chapter.

Rear Frame Removal

- Remove:
 - Seat (see Seat Removal)
 - Right & Left Side Cover (see Side Cover Removal)
 - Muffler (see Muffler Removal in the Engine Top End chapter)
 - Rear Fender (see Rear Fender Removal)
- Loosen the air cleaner duct clamp screw (see Air Cleaner Housing Removal in the Fuel System chapter).
- Unscrew the rear frame mounting bolts [A]. (KX450D6F ~ D7F)
- Remove the rear frame mounting bolts [A] and the washer at right lower frame. (KX450D8F)
- Remove the rear frame [B] with air cleaner housing [C].
- Remove:
 - Bolts [A]
 - Air Cleaner Housing [B]

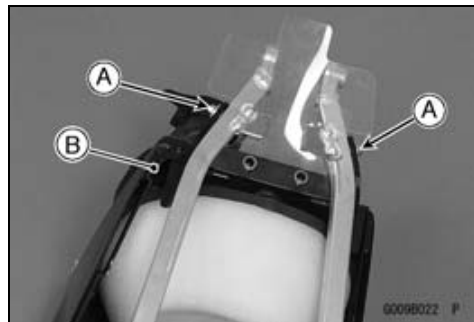
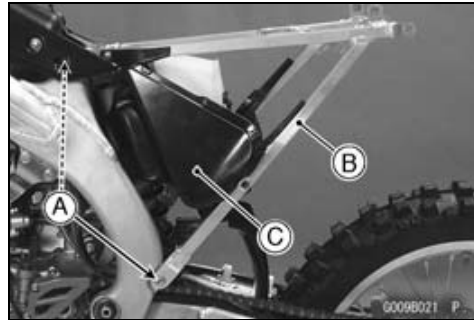

Rear Frame Installation

- Install the air cleaner housing.
- Tighten:
 - Torque - Rear Frame Mounting Bolts: 34 N·m (3.5 kgf·m, 25 ft·lb)**
- Install the removed parts.

Frame**Engine Guard Installation**

- Install the engine guard as shown.

Right Engine Guard [A]

Collar [B]

Bolt [C]

Engine Guard [D]

Bolts [E]

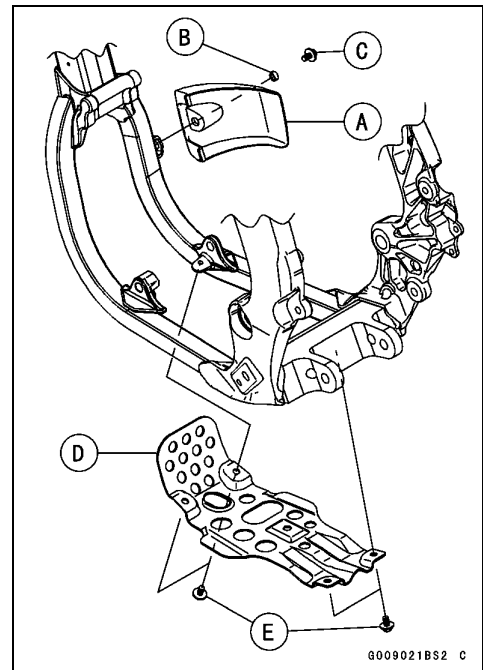

15-6 FRAME

Seat

Seat Removal

- Remove the bolts [A].
- Pull the seat [B] out from the back.

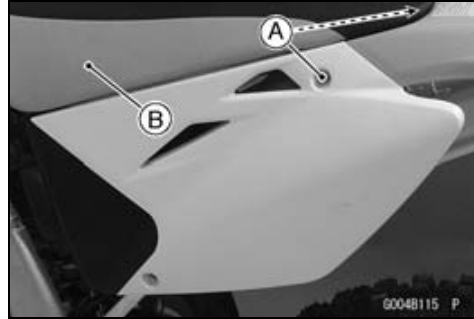

Seat Installation

- Insert the hooks [A] of the seat under the flange collar [B] and brackets [C].
- Tighten the seat mounting bolts.

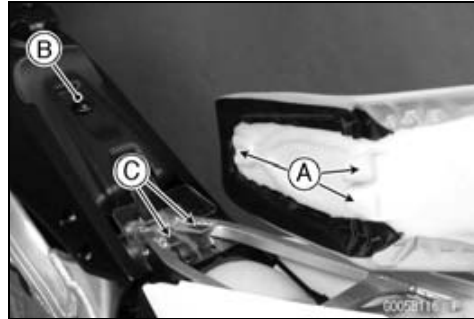

Side Cover

Side Cover Removal

- Remove:
 - Bolts [A]
 - Side Cover [B]
- Remove the other side according to similar procedure.

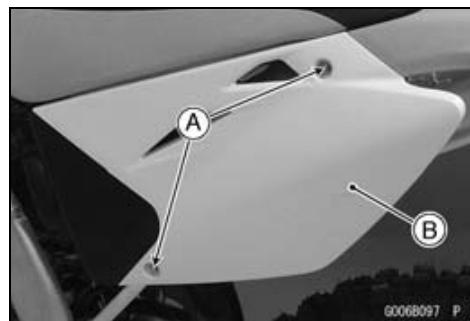

Side Cover Installation

- Stick the pads [A] on the inside of the right side cover [B].
- Install the dampers [C].

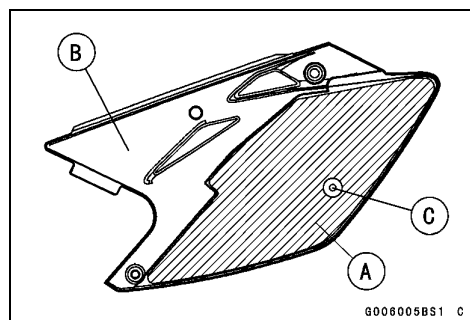

- Insert the tabs [A] of the cover into the air cleaner housing [B].

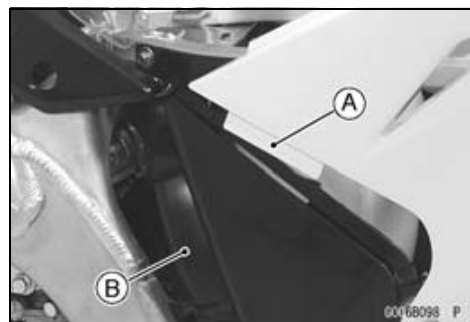

15-8 FRAME

Fender

Front Fender Removal

- Unscrew the bolts [A] and remove the front fender [B].

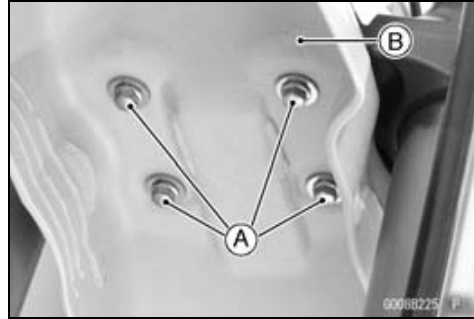

Rear Fender Removal

- Remove:
 - Seat (see Seat Removal)
- Unscrew the bolts [A] and remove the rear fender [B].

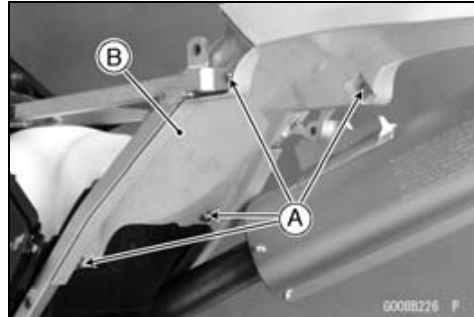

Rear Flap Removal

- Unscrew the screws [A] and remove the rear flap [B].

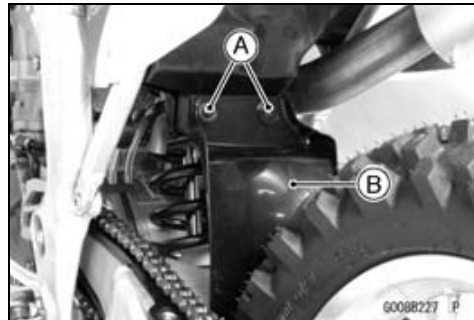

Electrical System

Table of Contents

Exploded View	16-2
Specifications	16-4
Special Tools and Sealant	16-5
Wiring Diagram	16-6
Precautions	16-7
Electrical Wiring	16-8
Wiring Inspection	16-8
Flywheel Magneto	16-9
Magneto Cover Removal	16-9
Magneto Cover Installation	16-9
Flywheel Removal	16-9
Flywheel Installation	16-10
Stator Removal	16-11
Stator Installation	16-11
Flywheel Inspection	16-11
Ignition Timing	16-13
Ignition Timing Inspection	16-13
Ignition System	16-14
Safety Instructions	16-14
Ignition Coil Removal	16-14
Ignition Coil Installation	16-14
Ignition Coil Inspection	16-15
Spark Plug Cleaning and Inspection	16-15
Spark Plug Gap Inspection	16-16
C.D.I. Unit Removal	16-16
C.D.I. Unit Installation	16-16
C.D.I. Unit Inspection	16-16
Crankshaft Sensor Inspection	16-21
Throttle Sensor	16-22
Throttle Sensor Inspection	16-22
Throttle Sensor Position Adjustment	16-23
Switches	16-24
Engine Stop Switch Inspection	16-24
Gear Position Switch Removal	16-24
Gear Position Switch Installation	16-25
Gear Position Switch Inspection	16-25

16-2 ELECTRICAL SYSTEM

Exploded View

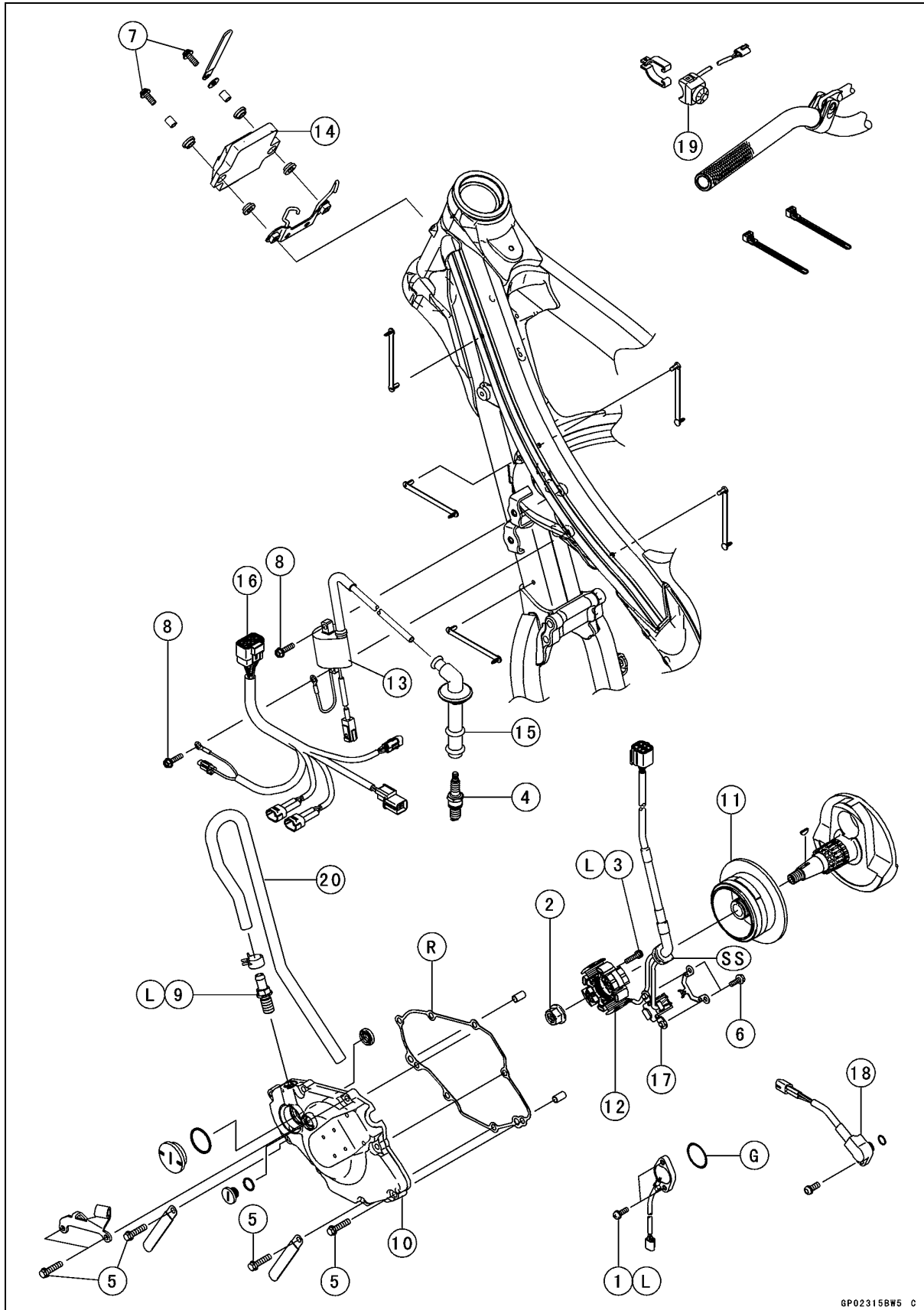

Exploded View

No.	Fastener	Torque			Remarks
		N·m	kgf·m	ft·lb	
1	Gear Position Switch Screws	2.9	0.30	26 in·lb	L
2	Flywheel Nut	78	8.0	58	
3	Stator Bolts	4.0	0.41	35 in·lb	L
4	Spark Plug	13	1.3	113 in·lb	
5	Magneto Cover Bolts	9.8	1.0	87 in·lb	
6	Crankshaft Sensor Bolts	7.0	0.71	62 in·lb	
7	C.D.I. Unit Bolts	9.8	1.0	87 in·lb	
8	Ignition Coil Bolts	7.0	0.71	62 in·lb	
9	Breather Fitting	15	1.5	11	L

10. Magneto Cover

11. Flywheel

12. Stator

13. Ignition Coil

14. C.D.I. Unit

15. Spark Plug Cap

16. Main Harness

17. Crankshaft Sensor

18. Throttle Sensor

19. Engine Stop Switch

20. Breather Hose

G: Apply grease.

L: Apply a non-permanent locking agent.

R: Replacement Parts

SS: Apply silicon sealant.

16-4 ELECTRICAL SYSTEM

Specifications

Item	Standard
Magneto	
Crankshaft Sensor Resistance	180 ~ 280 Ω (at 20°C (68°F))
Magneto Output Voltage	in the text
Stator Coil Resistance	in the text
Ignition System	
Ignition Timing	10° BTDC @1 800 r/min (rpm)
Ignition Coil:	
3 Needle Arcing Distance	7 mm (0.26 in.) or more
Primary Winding Resistance	0.28 ~ 0.38 Ω (at 20°C (68°F))
Secondary Winding Resistance	7.65 ~ 10.35 k Ω (at 20°C (68°F))
Spark Plug:	
Type	NGK CPR8EB-9
Gap	0.8 ~ 0.9 mm (0.03 ~ 0.04 in.)
C.D.I. Unit	in the text
Throttle Sensor	
Input Voltage	around 5 V
Output Voltage:	
when the Throttle Valve Completely Closed	0.58 ~ 0.78 V
when the Throttle Fully Opened	3.5 ~ 3.7 V

Special Tools and Sealant

Timing Light:
57001-1241

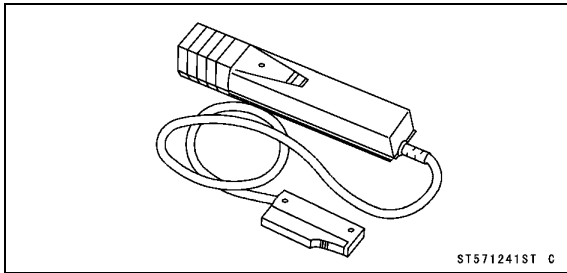

Filler Cap Driver:
57001-1454

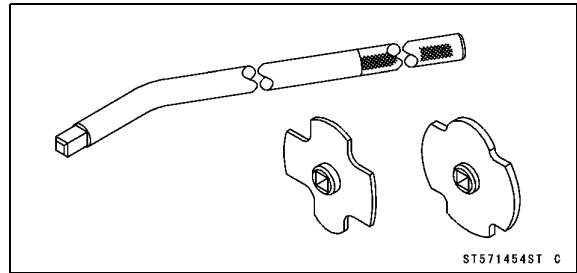

Spark Plug Wrench, Hex 16:
57001-1262

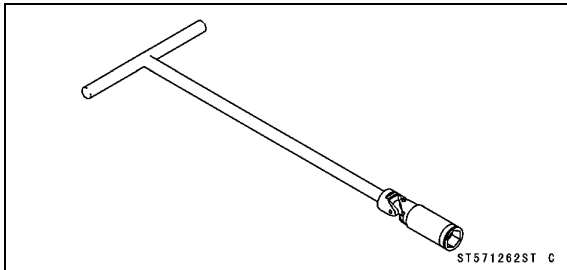

Needle Adapter Set:
57001-1457

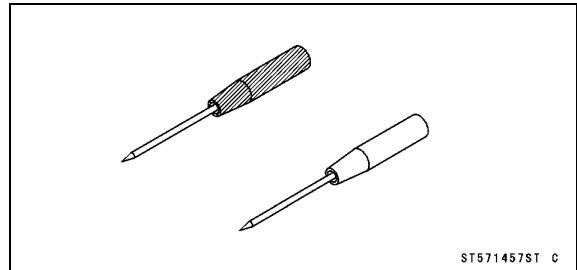

Hand Tester:
57001-1394

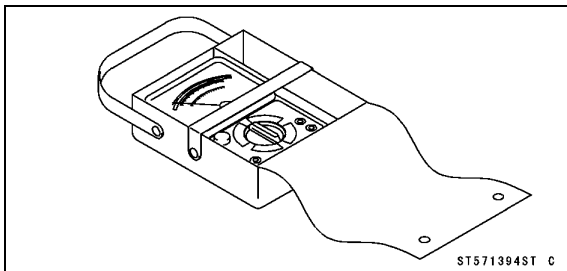

Rotor Puller:
57001-1565

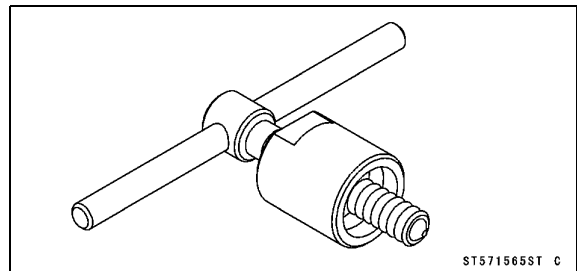

Throttle Sensor Setting Adapter #1:
57001-1400

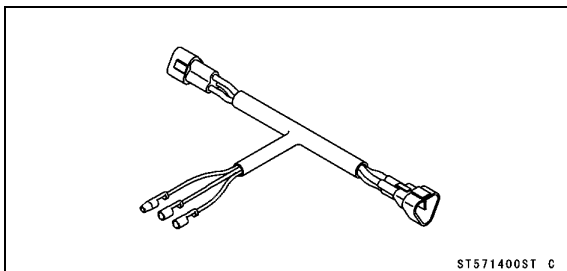

Rotor Holder:
57001-1654

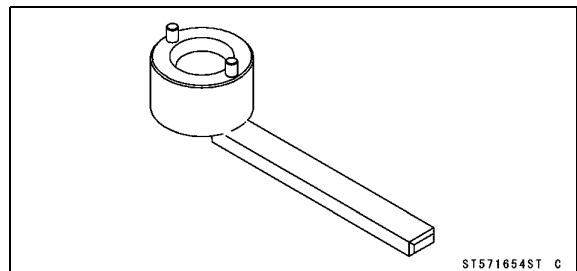

Peak Voltage Adapter:
57001-1415

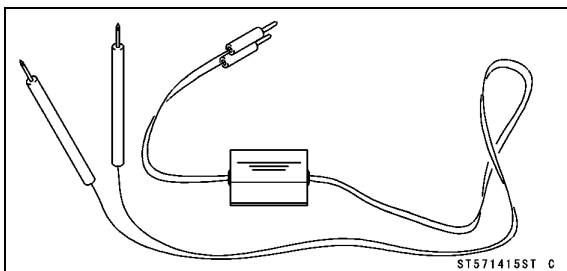

Kawasaki Bond (Silicone Sealant):
92104-0004

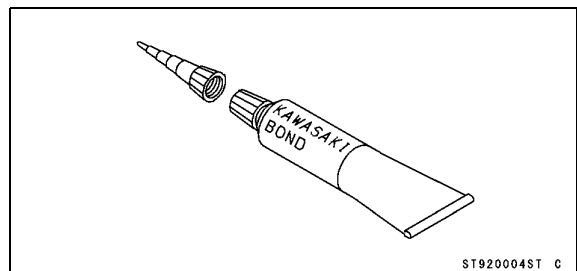

16-6 ELECTRICAL SYSTEM

Wiring Diagram

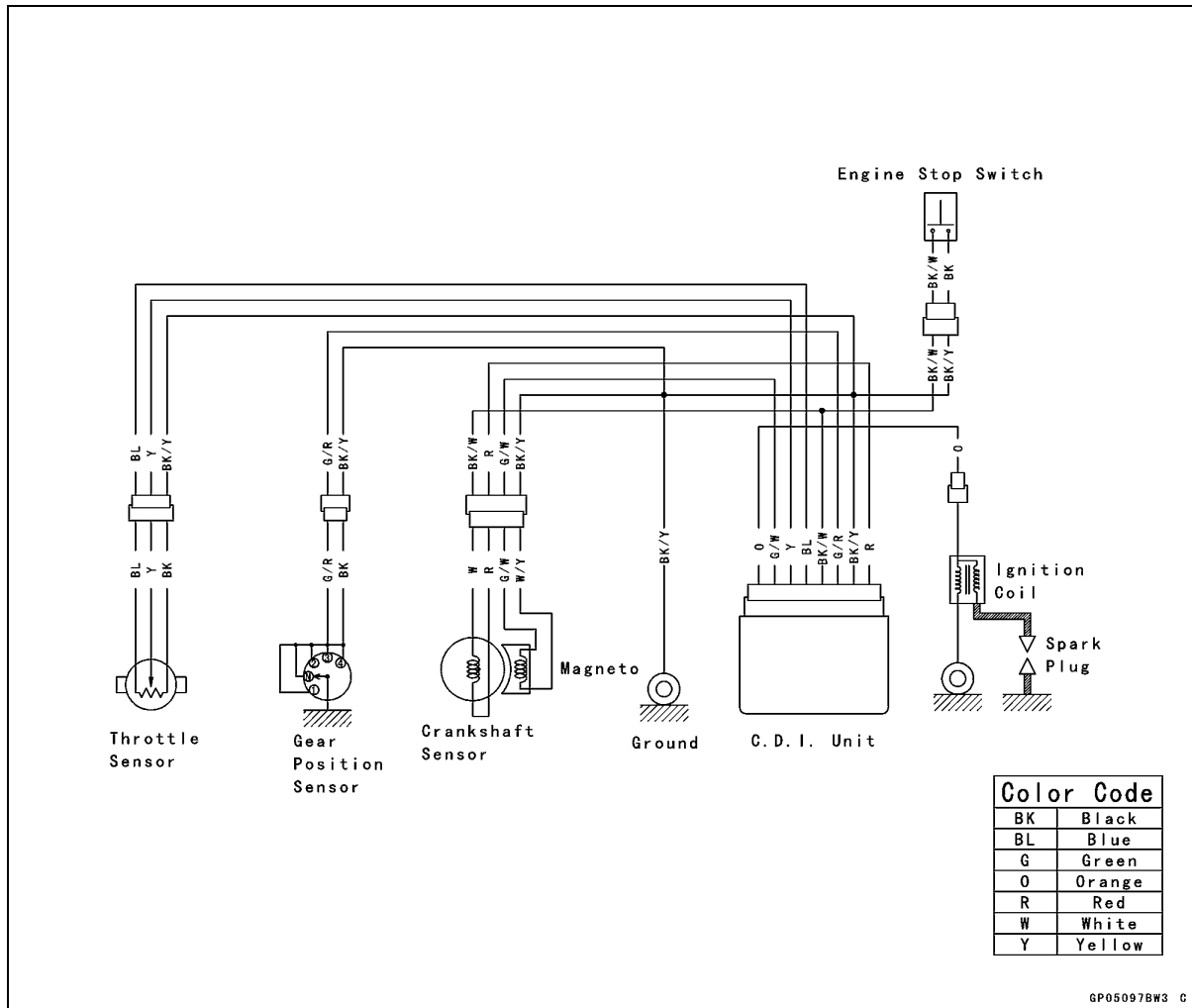

Precautions

There are numbers of important precautions that are musts when servicing electrical systems. Learn and observe all the rules below.

- The electrical parts should never be struck sharply, as with a hammer, or allowed to fall on a hard surface. Such a shock to the parts can damage them.
- Troubles may involve one or in some cases all items. Never replace a defective part without determining what CAUSED the failure. If the failure was caused by some other item or items, they too must be repaired or replaced, or the new replacement will soon fail again.
- Make sure all connectors in the circuit are clean and tight, and examine leads for signs of burning, fraying, etc. Poor leads and bad connections will affect electrical system operation.
- Measure coil and winding resistance when the part is cold (at room temperature).
- Electrical Connectors

Connectors [A]

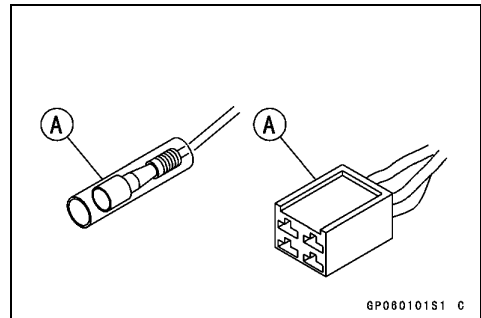

Connectors [B]

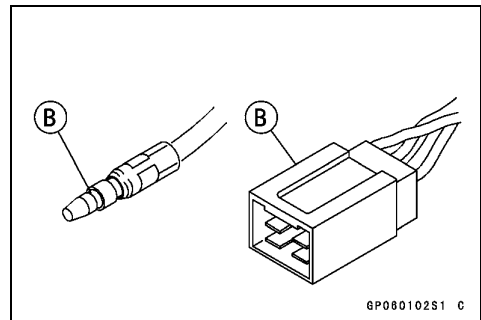

Safety Instructions:

WARNING

The ignition system produces extremely high voltage. Do not touch the spark plug, ignition coil or high tension lead while the engine is running, or you could receive a severe electrical shock.

16-8 ELECTRICAL SYSTEM

Electrical Wiring

Wiring Inspection

- Visually inspect the wiring for signs of burning, fraying, etc.
- ★ If any wiring is poor, replace the damaged wiring.
- Pull each connector [A] apart and inspect it for corrosion, dirt, and damage.
- ★ If the connector is corroded or dirty, clean it carefully. If it is damaged, replace it.
- Check the wiring for continuity.
- Use the wiring diagram to find the ends of the lead which is suspected of being a problem.
- Connect an ohmmeter between the ends of the leads.
- Set the meter to the $\times 1 \Omega$ range, and read the meter.
- ★ If the meter does not read 0Ω , the lead is defective. Replace the lead or the wiring harness if necessary.

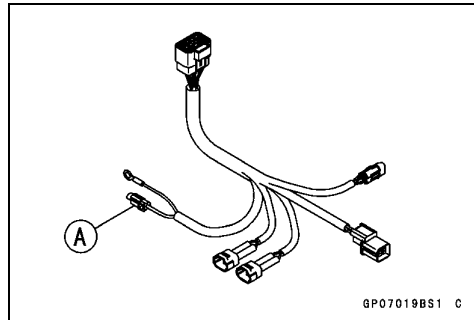

Flywheel Magneto

Magneto Cover Removal

- Remove the left radiator shroud.
- Drain the engine oil from the crank room oil sump (see Engine Oil Change in the Periodic Maintenance chapter).
- Pull the stopper [A] to this side to remove the magneto lead connector [B].
- Disconnect the magneto lead connector from the main harness.

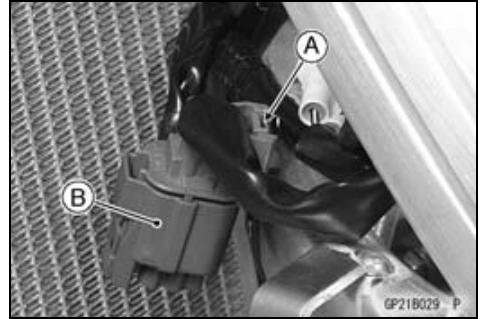

- Remove the shift pedal (see External Shift Mechanism Removal in the Engine Right Side chapter).
- Open the clamp [A] then free the breather hose [B].
- Remove:
 - Magneto Cover Mounting Bolts [C].
 - Magneto Cover [D].

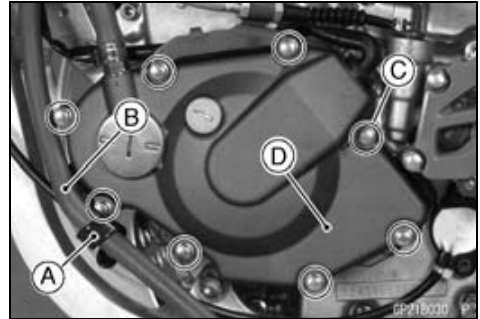

Magneto Cover Installation

- Replace the gasket with a new one.
- Be sure to install the dowel pins [A].

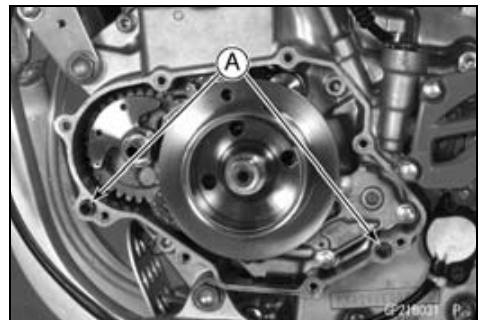

- Apply silicone sealant to the area [A] to the magneto lead grommet.

Sealant - Kawasaki Bond (Silicone Sealant): 92104-0004



- Put in the magneto lead to the lead holder [A].
- Tighten:
 - Torque - Magneto Cover Bolts: 9.8 N·m (1.0 kgf·m, 87 in·lb)**
- Run the breather hose [B] and magneto lead according to the Cable, Wire, and Hose Routing section in the Appendix chapter.
- Connect the lead connector.

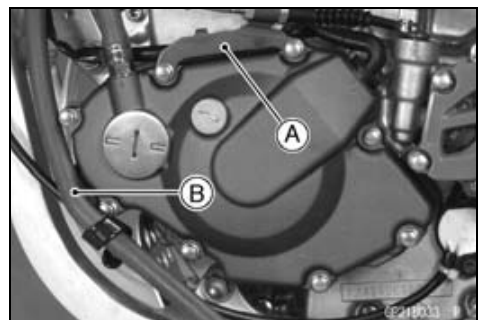

Flywheel Removal

- Remove the magneto cover (see Magneto Cover Removal).

16-10 ELECTRICAL SYSTEM

Flywheel Magneto

- Hold the flywheel steady with the rotor holder [A], and remove the flywheel nut [B].

Special Tool - Rotor Holder: 57001-1654

- Remove the rotor holder.

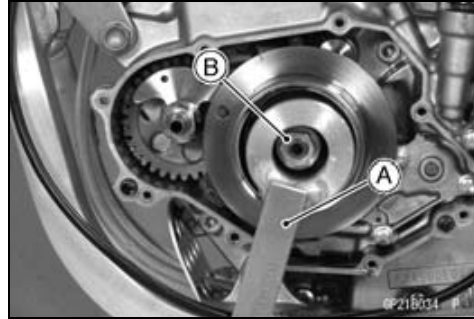

- Screw the rotor puller [A] into the flywheel.
- Remove the flywheel from the crankshaft by turning in the puller center bolt and tapping the head of the bolt lightly with a hammer, while holding the puller body steady. There is a woodruff key in the crankshaft tapered portion.

Special Tool - Rotor Puller: 57001-1565

CAUTION

Never strike the grab bar or the flywheel itself. Striking the bar can bond it. If the flywheel is struck, the magnets may lose their magnetism.

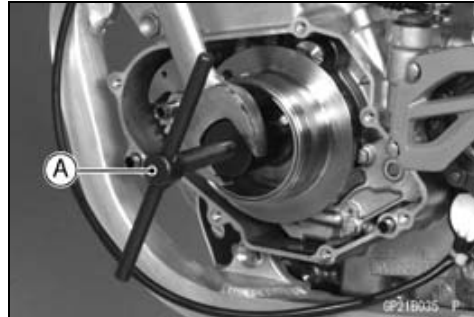

Flywheel Installation

- Using a high-flash point solvent, clean off any oil or dirt that may be on the crankshaft taper [A] or in the hole [B] of the flywheel. Dry them with a clean cloth.
- Fit the woodruff key [C] securely in the slot of the crankshaft.
- Install the flywheel according to the following procedures.

NOTE

○ Confirm the flywheel fit or not to the crankshaft before tightening it with specified torque.

- Install the flywheel and tighten it with 45 N·m (4.5 kgf·m, 33 ft·lb) of torque.
- Remove the flywheel nut.
- Check the tightening torque with rotor puller.
- ★ If the flywheel is not pulled out with 20 N·m (2 kgf·m, 15 ft·lb) of drawing torque, it is installed correctly.
- ★ If the flywheel is pulled out with under 20 N·m (2 kgf·m, 15 ft·lb) of drawing torque, clean off any oil dirt or flaw of the crankshaft and flywheel tapered portion, and dry them with a clean cloth. Then, confirm that it is not pulled out with above torque.

- Hold the flywheel steady with the rotor holder, and tighten the flywheel nut.

Special Tool - Rotor Holder: 57001-1654

Torque - Flywheel Nut: 78 N·m (8.0 kgf·m, 58 ft·lb)

- Install the magneto cover (see Magneto Cover Installation)

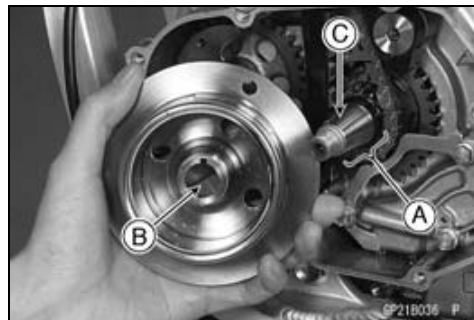

Flywheel Magneto

Stator Removal

- Remove:
 - Magneto Cover (see Magneto Cover Removal)
 - Stator Bolts [A]
 - Crankshaft Sensor Bolts [B]
 - Wiring Holder [C]
 - Wiring Grommet [D]
- Remove the stator [E] and crankshaft sensor [F] as a set.

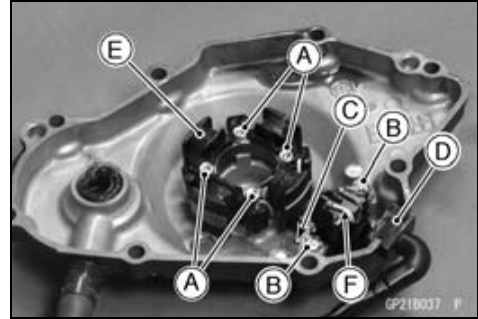

Stator Installation

- Route the leads according to the Cable, Wire, and Hose Routing section in the Appendix chapter.
- Apply a non-permanent locking agent to the stator bolts.
- Install the stator and tighten the stator bolts.

Torque - Stator Bolts: 4.0 N·m (0.41 kgf·m, 35 in·lb)

- Install the crankshaft sensor and wiring holder [A].
- Run the magneto leads under the holder and sensor.

Torque - Crankshaft Sensor Bolts: 7.0 N·m (0.71 kgf·m, 61 in·lb)

- Apply silicone sealant around the circumference of the wiring grommet.

Sealant - Kawasaki Bond (Silicone Sealant): 92104-0004

- Set the stator wiring grommet [B] securely in the notch [C].
- Install the magneto cover (see Magneto Cover Installation).

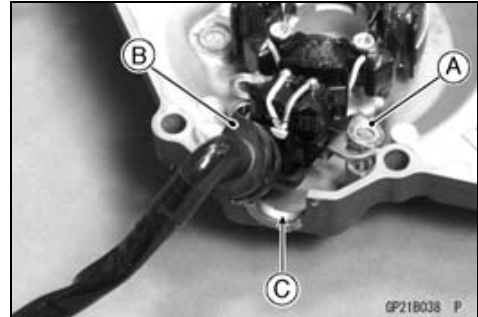

Flywheel Inspection

- There are three types of magneto problems: short, open (lead burned out), or loss in flywheel. A short or open in one of the coil leads will result in either a low output, or no output at all. A loss in flywheel, which may be caused by dropping or hitting the flywheel by leaving it near an electromagnetic field, or just by aging, will result in low output.
- Check the magneto output voltage, do the following procedures.
 - Remove the left radiator shroud.
 - Pull the stopper [A] to this side and remove the magneto lead connector [B].

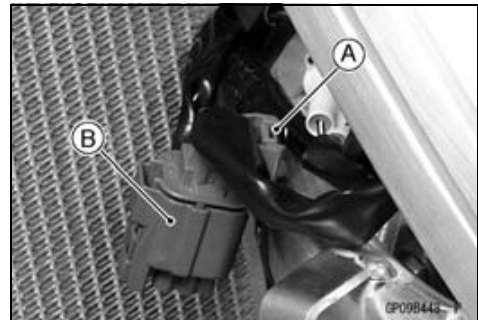

16-12 ELECTRICAL SYSTEM

Flywheel Magneto

- Connect the hand tester [A] to the connector [B] as shown in the table 1, using the needle adapter set [C].
- Start the engine.
- Run it at the rpm given in the table 1.
- Note the voltage readings (total 2 measurements).

Special Tools - Hand Tester: 57001-1394

Needle Adapter Set: 57001-1457

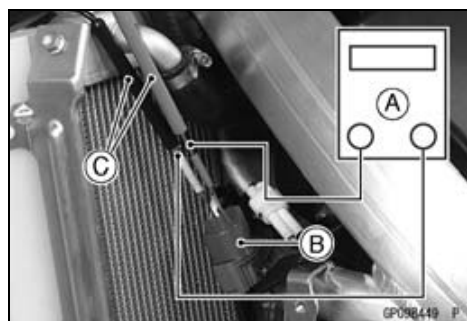

Table 1 Magneto Output Voltage

Tester Range	Connections		Reading @4 000 rpm
	Tester (+) to	Tester (-) to	
50 V AC	White lead	Red lead	20 V or more

- ★ If the output voltage shows the value in the table, the magneto operates properly.
- ★ If the output voltage shows a much lower reading than that given in the table it indicates that the magneto is defective.
- To check the stator coil resistance as follows.
 - Stop the engine.
 - Disconnect the auxiliary leads.
 - Connect the hand tester as shown in the table 2.
 - Note the readings (total 2 measurement).

Table 2 Stator Coil Resistance

Tester Range	Connections		Reading
	Tester (+) to	Tester (-) to	
× 1 Ω	Red lead	White lead	30 ~ 60 Ω
× 10 Ω	Green/White lead	Yellow lead	180 ~ 280 Ω

- ★ If there is more resistance than shown in the table, or no hand tester reading (infinity), the stator has an open lead and must be replaced. Much less than this resistance means the stator is shorted, and must be replaced.
- Using the highest resistance range of the hand tester, measure the resistance between each leads and chassis ground.
- ★ Any hand tester reading less than infinity (∞) indicates a short, necessitating stator replacement.
- ★ If the stator coils have normal resistance, but the voltage check showed the magneto to be defective; then the flywheel have probably weakened, and the flywheel must be replaced.

Special Tool - Hand Tester: 57001-1394

Ignition Timing

Ignition Timing Inspection

- Remove the timing inspection plug [A].

Special Tool - Filler Cap Driver: 57001-1454

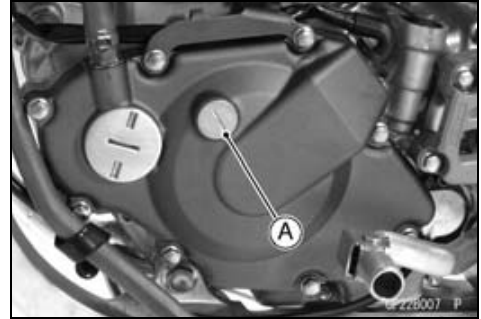

- Attach the timing light [A] to the ignition coil lead in the manner prescribed by the manufacturer.

Special Tool - Timing Light: 57001-1241

- Start the engine and aim the timing light at the ignition timing mark [B] on the flywheel.
- Run the engine at the speeds specified and note the alignment of the ignition timing marks.

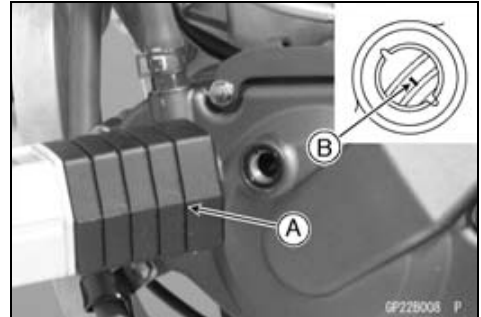

- Check the engine speed, using the engine revolution tester [A] for high accuracy.



Ignition Timing

Engine speed [r/min (rpm)]	Hole groove aligns with:
1 800	Line mark on flywheel

- ★ If the ignition timing is incorrect, check the crankshaft sensor (see Crankshaft Sensor Inspection).
- ★ If the crankshaft sensor are normal, check the C.D.I. unit (see C.D.I. Unit Inspection).
- Install the timing inspection plug.

16-14 ELECTRICAL SYSTEM

Ignition System

Safety Instructions

⚠ WARNING

The ignition system produces extremely high voltage. Do not touch the spark plug, ignition coil, or high tension lead while the engine is running, or you could receive a severe electrical shock.

Ignition Coil Removal

- Remove:
 - Fuel Tank (Fuel Tank Removal in the Fuel System chapter)
 - Bolt [A]
 - Left Radiator Screen [B]
 - Left Radiator Mounting Bolts [C]
- Push the left radiator forward [D].

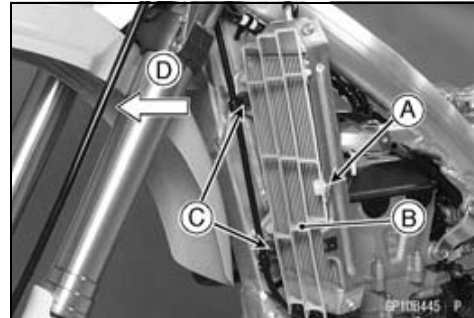

- Pry open the clamps [A].



- Disconnect the ignition coil primary lead connector [A].
- Pull the plug cap off the spark plug.
- Unscrew the mounting bolts [B], and remove the ignition coil [C].

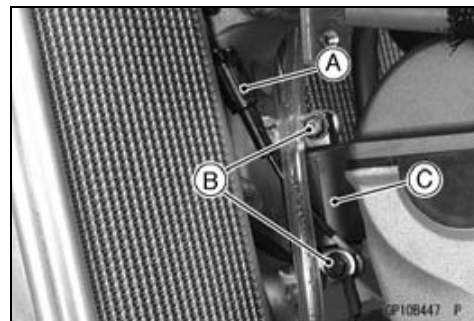

Ignition Coil Installation

- Ignition coil installation is the reverse of removal.
 - Torque - Ignition Coil Bolts: 7.0 N·m (0.71 kgf·m, 62 in·lb)**

Ignition System

Ignition Coil Inspection

Measuring arcing distance

The most accurate test for determining the condition of the ignition coil is made by measuring arcing distance using the coil tester for the 3-needle method.

- Remove the ignition coil.
- Connect the ignition coil (with the spark plug cap left installed on the spark plug lead) [A] to the tester [B], and measure the arcing distance.

⚠ WARNING

To avoid extremely high voltage shocks, do not touch the coil or lead.

- ★ If the distance reading is less than the specified value, the ignition coil or spark plug cap is defective.

3 Needle Arcing Distance

Standard: 7 mm (0.26 in.) or more

- To determine which part is defective, measure the arcing distance again with the spark plug cap removed from the ignition coil lead.
- ★ If the arcing distance is subnormal as before, the trouble is with the ignition coil itself. If the arcing distance is now normal, the trouble is with the spark plug cap.

Measuring Coil Resistance

If the arcing tester is not available, the coil can be checked for a broken or badly shorted winding with an ohmmeter. However, an ohmmeter cannot detect layer shorts and shorts resulting from insulation breakdown under high voltage.

- Remove the ignition coil (see Ignition Coil Removal).
- Measure the primary winding resistance [A].
 - Connect an ohmmeter between the coil terminals.
 - Set the meter to the x 1 Ω range, and read the meter.
- Measure the secondary winding resistance [B].
 - Pull the spark plug cap off the lead.
 - Connect an ohmmeter between the high tension lead and the ground lead terminal.
 - Set the meter to the x 1 k Ω range, and read the meter.

Ignition Coil Winding Resistance

Primary windings: 0.28 ~ 0.38 Ω (at 20°C (68°F))

Secondary windings: 7.65 ~ 10.35 k Ω (at 20°C (68°F))

- ★ If the meter does not read as specified, replace the coil.
- ★ If the meter reads as specified, the ignition coil windings are probably good. However, if the ignition system still does not perform as it should after all other components have been checked, test replace the coil with one known to be good.
- Check the high tension lead for visible damage.
- ★ If the high tension lead is damaged, replace the ignition coil.

Spark Plug Cleaning and Inspection

- Refer to the Spark Plug Cleaning and Inspection in the Periodic Maintenance chapter.

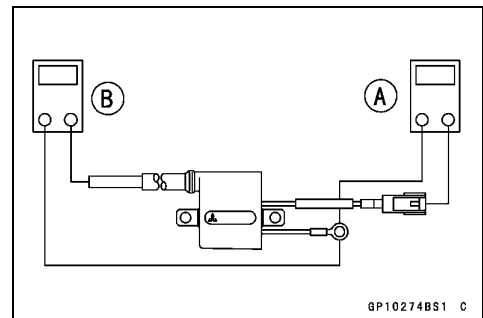
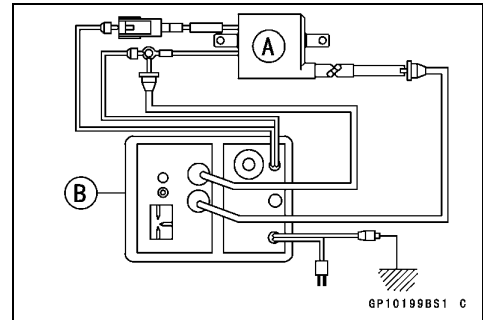

16-16 ELECTRICAL SYSTEM

Ignition System

Spark Plug Gap Inspection

- Refer to the Spark Plug Cleaning and Inspection in the Periodic Maintenance chapter.

C.D.I. Unit Removal

- Remove:
 - Belt (Open) [A]
 - Bolt [B]
 - Number Plate [C]

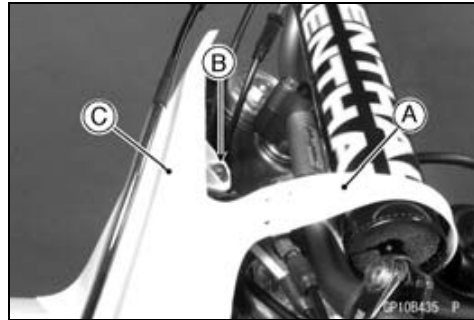

- Disconnect the main harness connector [A].
- Unscrew the mounting bolts [B] and remove the C.D.I. Unit [C].

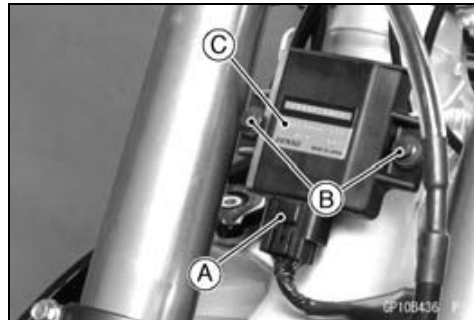

C.D.I. Unit Installation

Torque - CDI Unit Bolts: 9.8 N·m (1.0 kgf·m, 87 in·lb)

C.D.I. Unit Inspection

CAUTION

**When inspecting the C.D.I. unit observe the following to avoid damage to the C.D.I. unit.
Do not disconnect the C.D.I. unit while the engine is running.
This may damage the C.D.I. unit.**

Ignition System

Ignition Coil Primary Peak Voltage Check

- Disconnect the spark plug cap from the spark plug, but do not remove the spark plug.
- Connect the good spark plug [A] to the spark plug cap, then touch the engine with it.

NOTE

- Measure the voltage with each lead connected correctly. The correct value may not be obtained if disconnected.
- Maintain the correct value of compression pressure for the cylinder (Be sure to measure the voltage with the spark plug installed to the cylinder head).
- Connect the peak voltage adapter [B] to the hand tester, and connect the black lead of adapter to the terminal of primary lead (orange), red lead of it to the ground connection of the ignition coil [C].
- Set the tester to DC 250 V range.

Special Tools - Hand Tester: 57001-1394

Peak Voltage Adapter: 57001-1415

Type: KEK-54-9-B

Needle Adapter Set: 57001-1457

Connection: Adapter Positive → Ground Lead [D]

Adapter Negative → Orange Lead [E]

C.D.I. Unit [F]

Needle Adapter [G]

- Shift the gear to the neutral position, then free the engine stop switch.
- Crank the engine by kicking the pedal several times to measure the peak voltage of the primary ignition coil.

Peak Voltage 128 V or above

⚠ WARNING

Do not touch the metal portion of the probe in case of measuring the voltage, or you may receive a serious electric shock.

- ★ If the voltage is less than the specified value, see the next page.

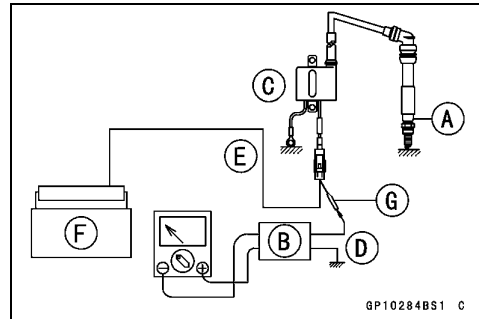
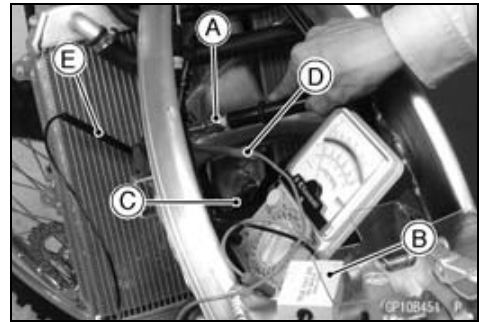

16-18 ELECTRICAL SYSTEM

Ignition System

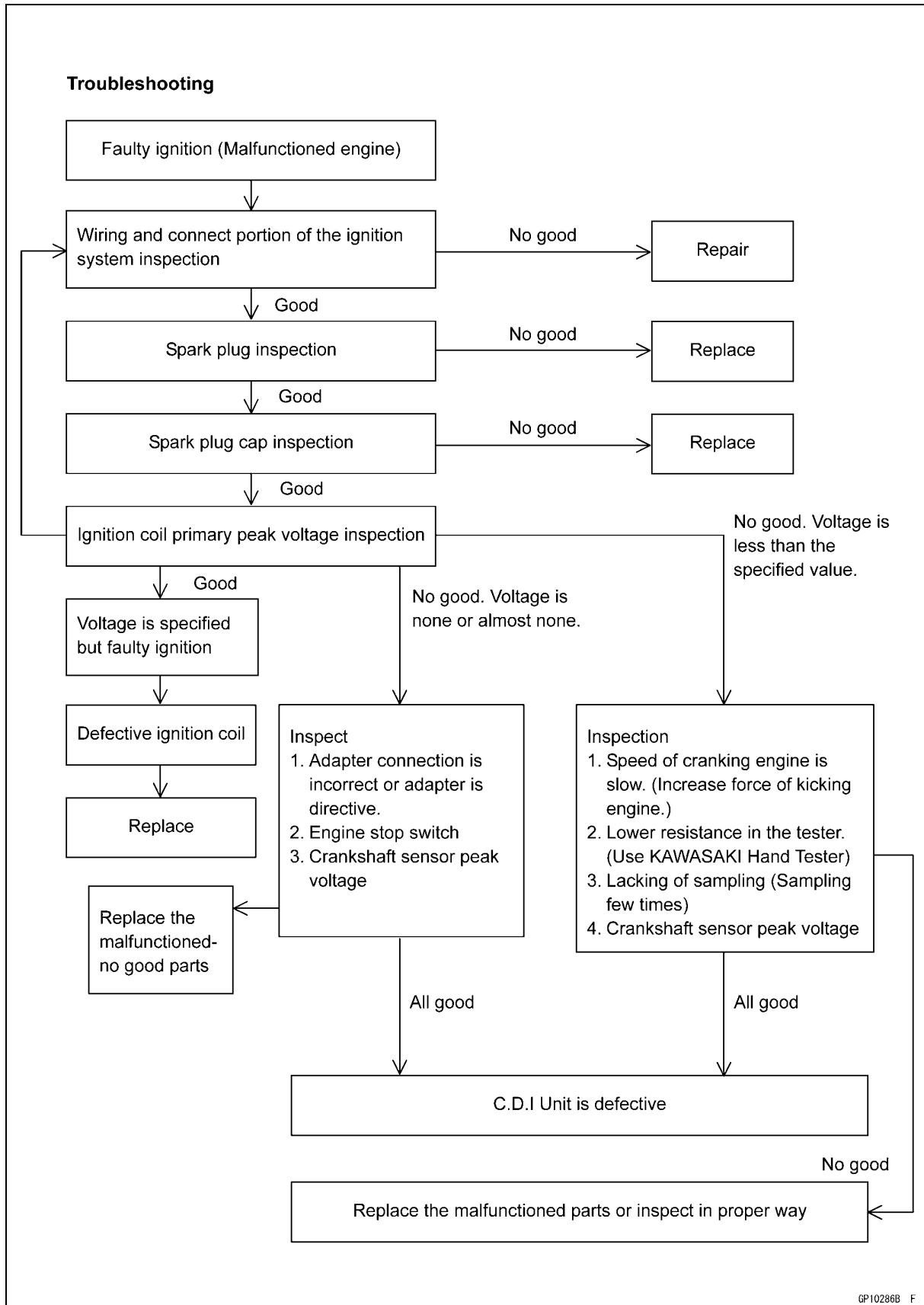

Ignition System

Crankshaft Sensor Peak Voltage Check

- To check the peak voltage, do the following procedures.
- Disconnect the connector of the magneto lead connector from the main harness.

NOTE

- Measure the voltage with each lead connected correctly. The correct value may not be obtained if disconnected.
- Maintain the correct value of compression pressure for the cylinder (Be sure to measure the voltage with the spark plug installed to the cylinder head).
- Set the hand tester to DC 2.5 V range.
- Connect the peak voltage adapter [A] to the tester and the terminals of the magneto lead connector [B].

Special Tools - Hand Tester: 57001-1394

Peak Voltage Adapter: 57001-1415

Type: KEK-54-9-B

Connection: Adapter Positive → Green/White Lead [C]

Adapter Negative → White/Yellow Lead [D]

- Crank the engine by kicking the pedal several times to measure the peak voltage of the crankshaft sensor.

Peak Voltage 1.1 V or above

⚠ WARNING

Do not touch the metal portion of the probe in case of measuring the voltage, or you may receive a serious electric shock.

- ★ If the voltage is less than the specified, check the crankshaft sensor.

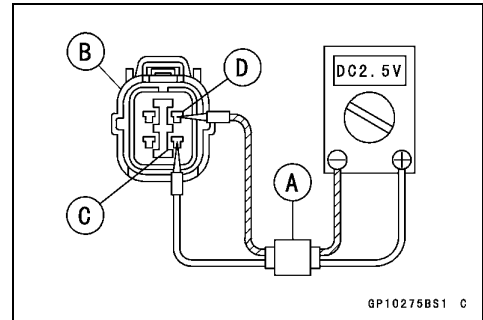

16-20 ELECTRICAL SYSTEM

Ignition System

Charge Coil Peak Voltage Check

- Disconnect the connector of the magneto lead connector from the main harness.
- To check the peak voltage, do the following procedures.

NOTE

- Measure the voltage with each lead connected correctly. The correct value may not be obtained if disconnected.
- Maintain the correct value of compression pressure for the cylinder (Be sure to measure the voltage with the spark plug installed to the cylinder head.)
- Connect the peak voltage adapter [A] to the tester and the terminals of the magneto lead connector [B].

Special Tools - Hand Tester: 57001-1394

Peak Voltage Adapter: 57001-1415

Type: KEK-54-9-B

Connection: Adapter Positive → White Lead [C]

Adapter Negative → Red Lead [D]

- Crank the engine by kicking the pedal several time to measure the peak voltage of the charge coil.

Peak Voltage: 20 V or Above

- ★ If the voltage is less than the specified, check the charge coil.

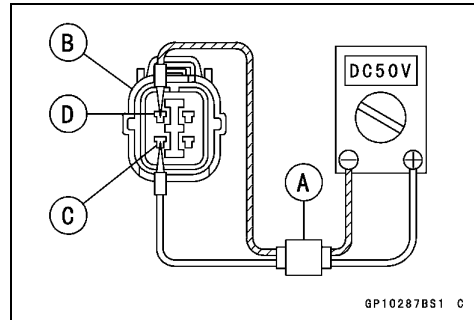

Throttle Sensor Output/Input Voltage Check

- Remove the carburetor transiently (see Carburetor Removal in the Fuel System chapter).
- Remove the throttle sensor lead connector [A].



- Connect the throttle sensor setting adapter [A] between throttle sensor lead connector [B] and main harness connector [C].

Special Tools - Hand Tester: 57001-1394

Throttle Sensor Setting Adapter #1: 57001-1400

- Set the Hand tester [D] to the DC 10 V range, and connect it to the adapter leads.

Hand Tester (+) → Yellow/White Lead

Hand Tester (-) → Black/Blue Lead

- Temporary install the fuel tank.
- Start the engine.
- Check the sensor input voltage with the engine running.

Throttle Sensor Input Voltage

Standard: around 5 V

- ★ If it is not within the specified voltage range, check the magneto output voltage. If it has normal functions, replace the C.D.I. Unit.

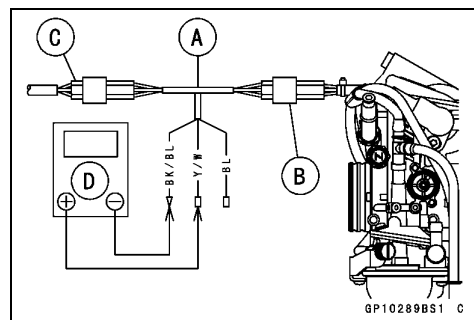

Ignition System

- To check the output voltage, do the following procedures.
- Connect the digital voltmeter [A] as follows.

Tester (+) → Blue Lead

Tester (-) → Black/Blue Lead

- Start the engine.
- Measure the throttle sensor output voltage with the engine idling speed and with the idle throttle valve opening.

Throttle Sensor Output Voltage

Standard: 0.68 ±0.1 V (when engine is idle speed.)

- ★ If it is not within the specified voltage range, adjust the throttle sensor position (see Throttle Sensor Position Adjustment).

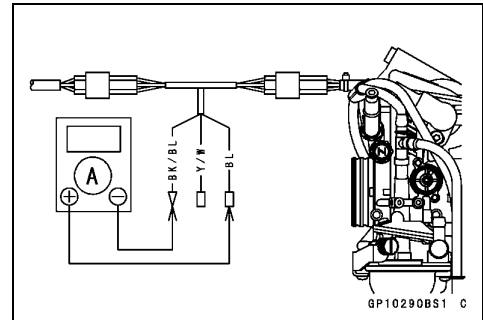

Engine Stop Switch Electric Current Check

- Remove the fuel tank transiently (see Fuel Tank Removal in the Fuel System chapter).
- Disconnect the engine stop switch lead connector [A].
- Temporarily install the fuel tank.
- Start the engine.
- Ground the stop switch black/white lead of the main harness side while the engine is running.
- ★ If the engine does not stop, replace the C.D.I. Unit.

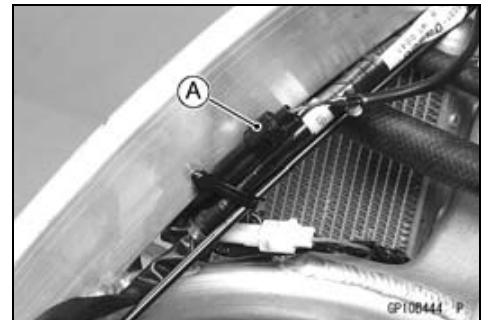

Crankshaft Sensor Inspection

- Remove:
 - Magneto Lead Connector (see Magneto Cover Removal).
- Set the hand tester [A] to the × 100 Ω range and connect it to the Green/White [B] and White/Yellow [C] Leads in the connector.

Special Tool - Hand Tester: 57001-1394

- ★ If there is more resistance than the specified value, the coil has an open lead and must be replaced. Much less than this resistance means the coil is shorted, and must be replaced.

Crankshaft Sensor Resistance

Standard: 180 ~ 280 Ω (at 20 °C (68 °F))

- Using the highest resistance range of the tester, measure the resistance between the crankshaft sensor leads and chassis ground.
- ★ Any tester reading less than infinity (∞) indicates a short, necessitates replacement of the crankshaft sensor assembly.

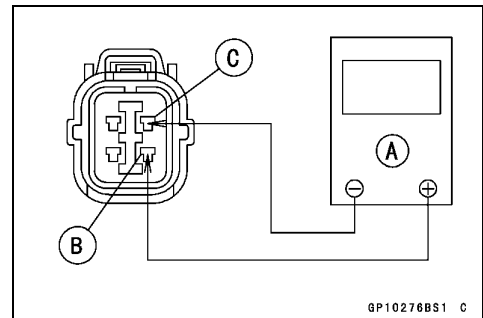

16-22 ELECTRICAL SYSTEM

Throttle Sensor

Throttle Sensor Inspection

NOTE

- If the variable rheostat is not available, refer to throttle sensor output/input voltage check in the C.D.I. Unit inspection.
- When inspecting the throttle sensor the throttle valve of the carburetor shall be completely closed and remain the throttle cable connected.
- Remove the carburetor (see Carburetor Removal in the Fuel System chapter).
- Connect the throttle sensor lead connector [A] with the battery [B], variable rheostat [C] and hand testers [D] as shown.
 - Variable Rheostat (+) → Blue Lead Terminal [E]
 - Hand Tester (+) → Yellow Lead terminal [F]
 - Hand Tester (−) → Black Lead terminal [G]
- Check the sensor input voltage.

Throttle Sensor Input Voltage

Standard: around 5 V

- Check the sensor output voltage with the throttle valve is completely closed.

Throttle Sensor Output Voltage

Standard: 0.68 ±0.1 V (when the engine speed is idle.)

- ★ If it is not within the specified voltage, adjust the throttle sensor position (see Throttle Sensor Position Adjustment).
- ★ If it is within specified voltage, go to next test.
- Check the sensor output voltage with the throttle fully opened.

Throttle sensor Output Voltage

Standard: 3.5 ~ 3.7 V (When throttle fully opened.)

- ★ If it is not within the specified voltage, replace the sensor.

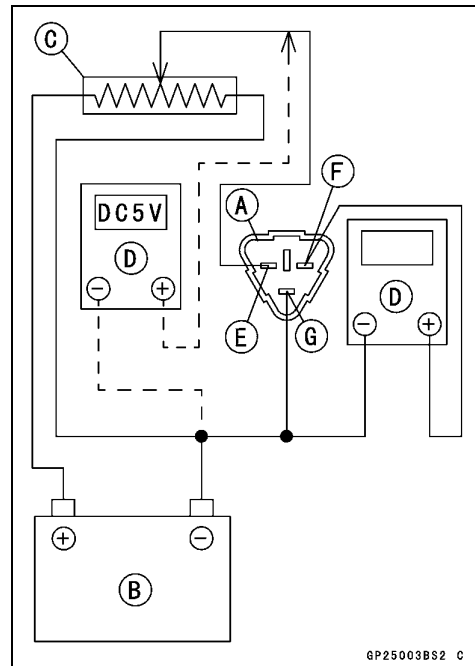

Throttle Sensor

Throttle Sensor Position Adjustment

- Remove the carburetor (see Carburetor Removal in the Fuel System chapter).
- Measure the resistance between the blue and black lead terminals of the sensor side connector.
 - Blue Lead Terminal [A]
 - Black Lead Terminal [B]
 - Yellow Lead Terminal [C]
 - Hand Tester [D]

Special Tool - Hand Tester: 57001-1394

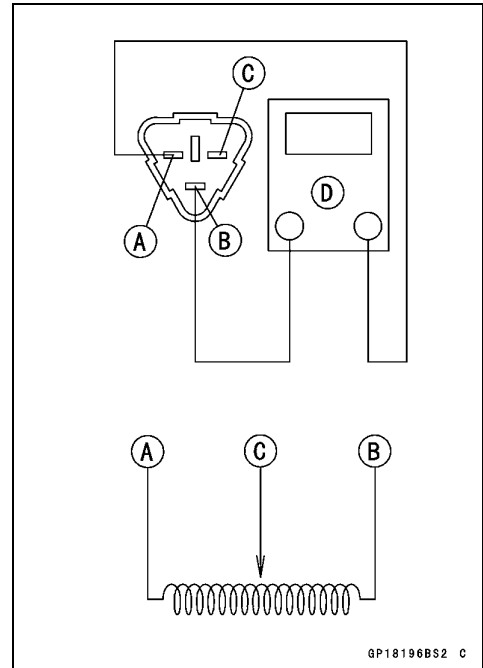

- Calculated the throttle sensor resistance at idle speed using the equation.

$$A \times \frac{0.58 \sim 0.78 \text{ V}}{5 \text{ V}} = B$$

A: Blue and Black lead terminal resistance

B: Throttle sensor resistance at idle speed

Example

- If the blue and black lead terminals resistance is 5 k Ω , then the throttle sensor resistance at idle speed is:

$$5 \text{ k}\Omega \times \frac{0.58 \sim 0.78 \text{ V}}{5 \text{ V}} = 580 \sim 780 \Omega$$

- Adjust the throttle sensor position so the resistance between yellow and black lead terminals is as calculated (example: 580 ~ 780 Ω).
- Loosen the throttle sensor mounting bolt [A].
- Adjust the position of the sensor [B] until the resistance is within the specified resistance range.
- ★ If it is not within the specified resistance range, replace the sensor.
- Install the carburetor (see carburetor Installation in the Fuel System chapter).
- Start the engine and warm it up thoroughly.
- Check the idle speed.
- ★ If the idle speed is out of the specified range, adjust it (see Idle speed Adjustment in the Periodic Maintenance chapter).

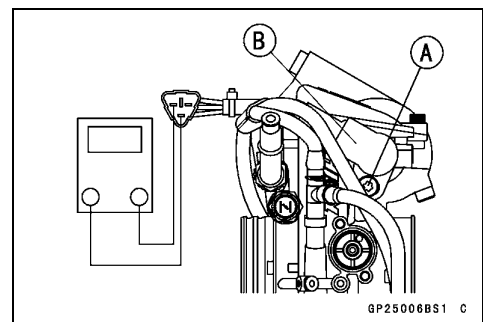

16-24 ELECTRICAL SYSTEM

Switches

Engine Stop Switch Inspection

- Using the hand tester, check to see that only the connections shown in the table have continuity (about zero ohms).

Special Tool - Hand Tester: 57001-1394

- ★ If the switch has an open or short, repair it or replace it with a new one.

Engine Stop Switch Connection

	Y	R
Stop		
Run	○—	—○

Gear Position Switch Removal

- Remove:
 - Bolt [A]
 - Left Radiator Screen [B]
 - Left Radiator Mounting Bolts [C]
- Push the left radiator forward [D].
- Pry open the clamps [A].
- Disconnect the gear position switch connector.
- Remove:
 - Shift Pedal (External Shift Mechanism Removal in the Engine Right Side chapter)
 - Screws [A]
 - Gear Position Switch [B]

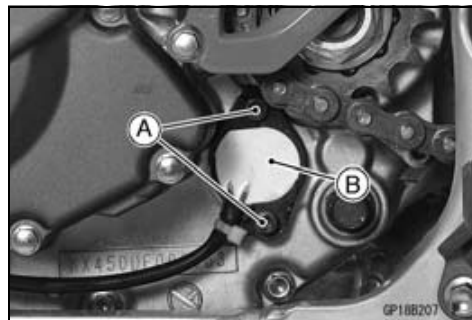
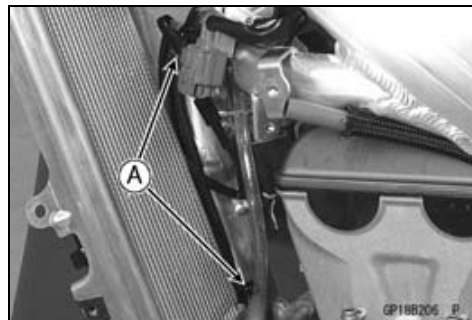
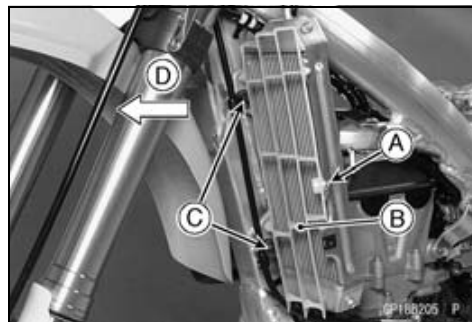

Switches

- Remove:
 - O-ring [A]
 - Gear Position Switch Finger [B]
 - Spring [C]

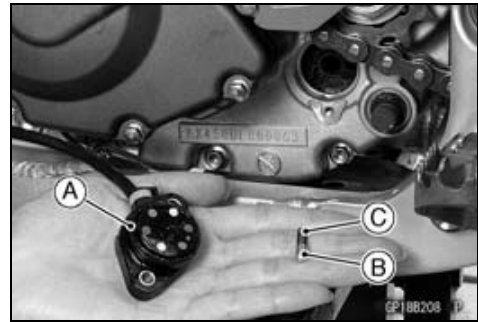

Gear Position Switch Installation

- Insert the spring into the hole in the shift drum.
- Insert the switch finger [A] so that the small diameter [B] is toward hole side.
- Apply grease to the O-ring.
- Clean the contact points on the position switch.
- Apply a non-permanent locking agent to the gear position switch screws.
- Tighten:
 - Torque - Gear Position Switch Screws: 2.9 N·m (0.30 kgf·m, 26 in·lb)**

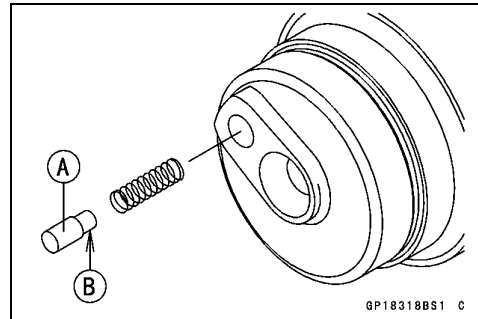

- Install the other removed parts.

Gear Position Switch Inspection

NOTE

- Be sure the transmission mechanism is good condition.
- Disconnect the gear position switch lead connector [A].

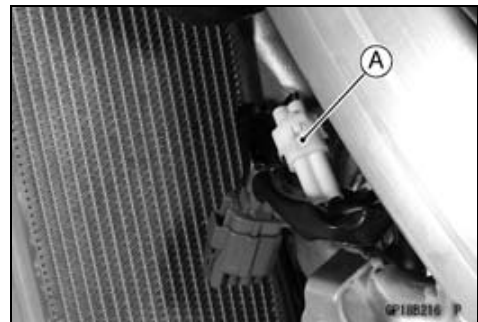

- Set the hand tester [A] to the $\times 1$ k Ω or $\times 100$ Ω range and connect it to the terminals in the gear position switch lead connector [B] and ground.
 - [C] Internal Circuit
 - [D] Green/Red Lead
 - [E] Black Lead

Special Tool - Hand Tester: 57001-1394

Gear Position Switch Resistance

Gear Position	Connections	
	[D] Terminal - Ground	[E] Terminal - Ground
Neutral	—	—
1st	3.00 ~ 3.32 k Ω	11.63 ~ 12.87 k Ω
2nd	1.70 ~ 1.89 k Ω	10.33 ~ 11.44 k Ω
3rd	1.07 ~ 1.19 k Ω	9.70 ~ 10.74 k Ω
4th	0.695 ~ 0.769 k Ω	9.32 ~ 10.32 k Ω

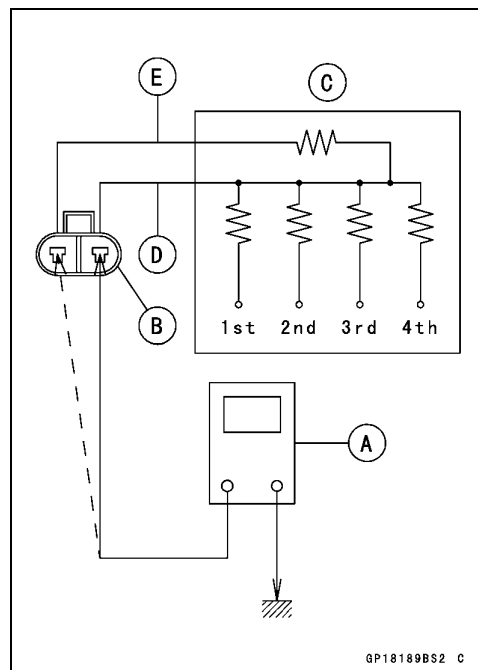

- ★ If the tester reading is not as specified, replace the gear position switch with a new one.

Appendix

Table of Contents

Cable, Wire, and Hose Routing	17-2
Troubleshooting Guide	17-8

17-2 APPENDIX

Cable, Wire, and Hose Routing

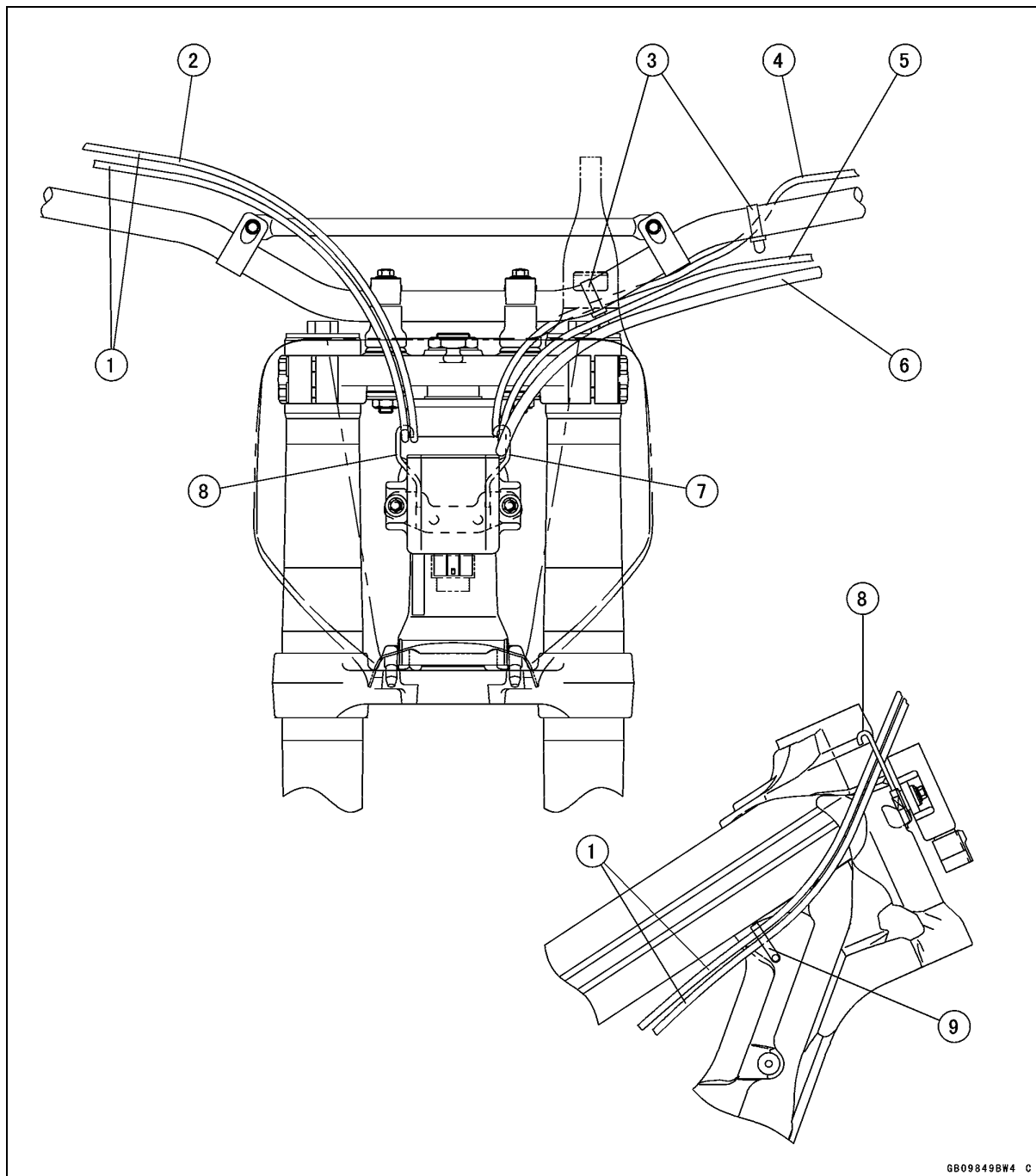

1. Throttle Cables
2. Marked (AAA) cable is accelerator side.
3. Band (Hold the engine stop switch lead.)
4. Engine Stop Switch Lead
5. Hot Starter Cable

6. Clutch Cable
7. Clamp (Clamp the clutch and hot starter cable.)
8. Clamp (Clamp the throttle cables.)
9. Clamp (Clamp the throttle cables.)

Cable, Wire, and Hose Routing

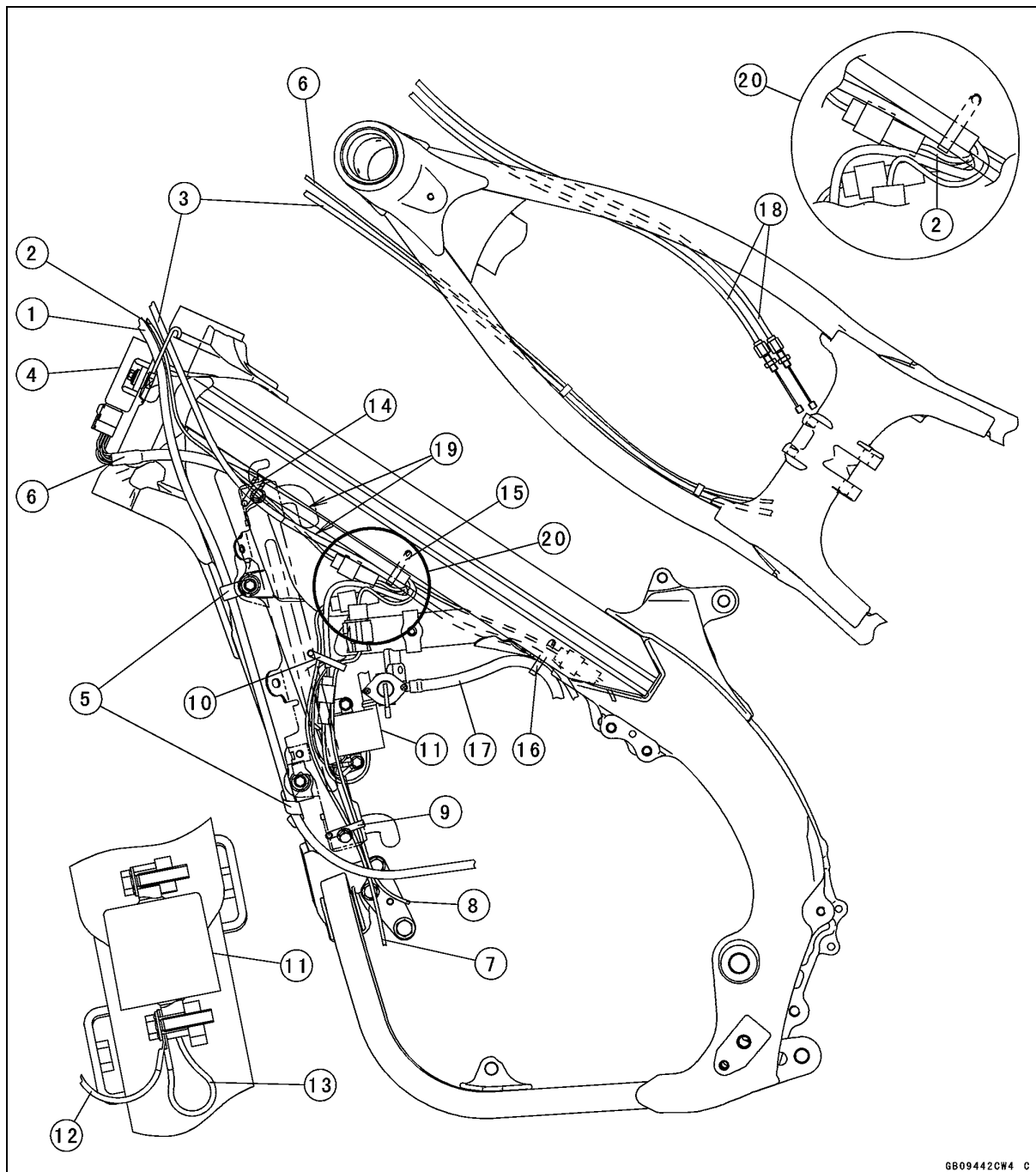

GB09442CW4 C

- | | |
|---|---|
| 1. Clutch Cable | 13. Ignition Coil Ground Lead |
| 2. Engine Stop Switch Lead | 14. Clamp (Clamp the hot starter cable, engine stop switch lead and main harness.) |
| 3. Hot Starter Cable | 15. Clamp (Clamp the hot starter cable and main harness.) |
| 4. C.D.I. Unit | 16. Clamp (Clamp the hot starter cable, main harness and fuel hose.) |
| 5. Clamps (Clamp the clutch cable.) | 17. Fuel Hose |
| 6. Main Harness | 18. Throttle Cables |
| 7. Gear Position Sensor Lead | 19. Run the hot starter cable, engine stop switch lead and main harness above the water hose. |
| 8. Flywheel Lead | 20. Do not clamp the engine stop switch lead. |
| 9. Clamp (Clamp the gear position sensor lead and magneto lead.) | |
| 10. Clamp (Clamp the main harness, gear position sensor lead and magneto lead.) | |
| 11. Ignition Coil | |
| 12. Ground Lead | |

17-4 APPENDIX

Cable, Wire, and Hose Routing

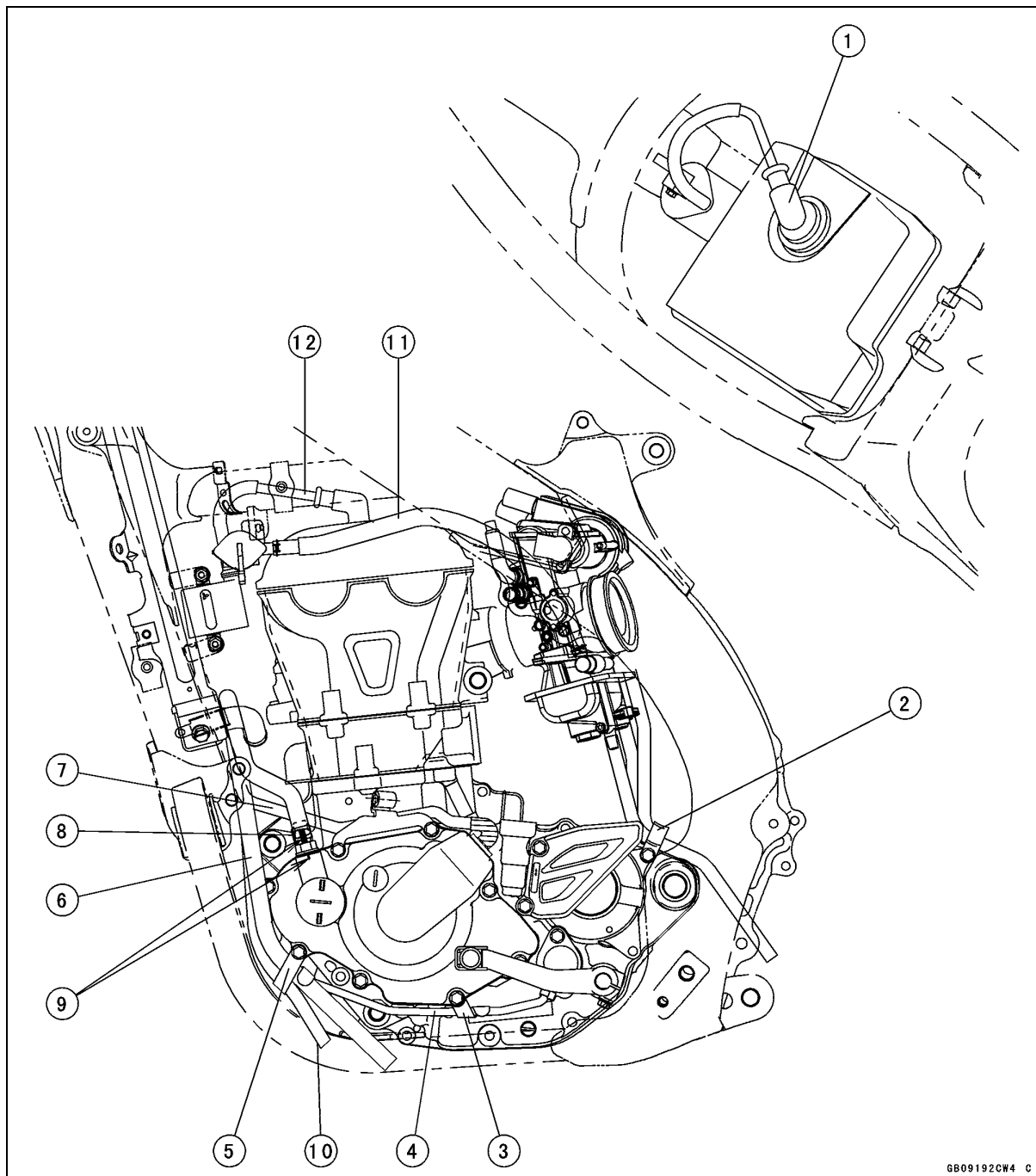

1. Spark Plug Cap
2. Clamp (Clamp the carburetor drain and air vent hoses.)
3. Clamp (Clamp the gear position sensor lead.)
4. Gear Position Sensor Lead
5. Clamp (Clamp the gear position sensor lead, radiator overflow hose and breather hose.)
6. Breather Hose
7. Flywheel Lead
8. Align the clamp claw and white mark on the breather hose.
9. Align the white mark on the breather hose and embossed mark.
10. Radiator Overflow Hose
11. Fuel Hose
12. High Tension Lead

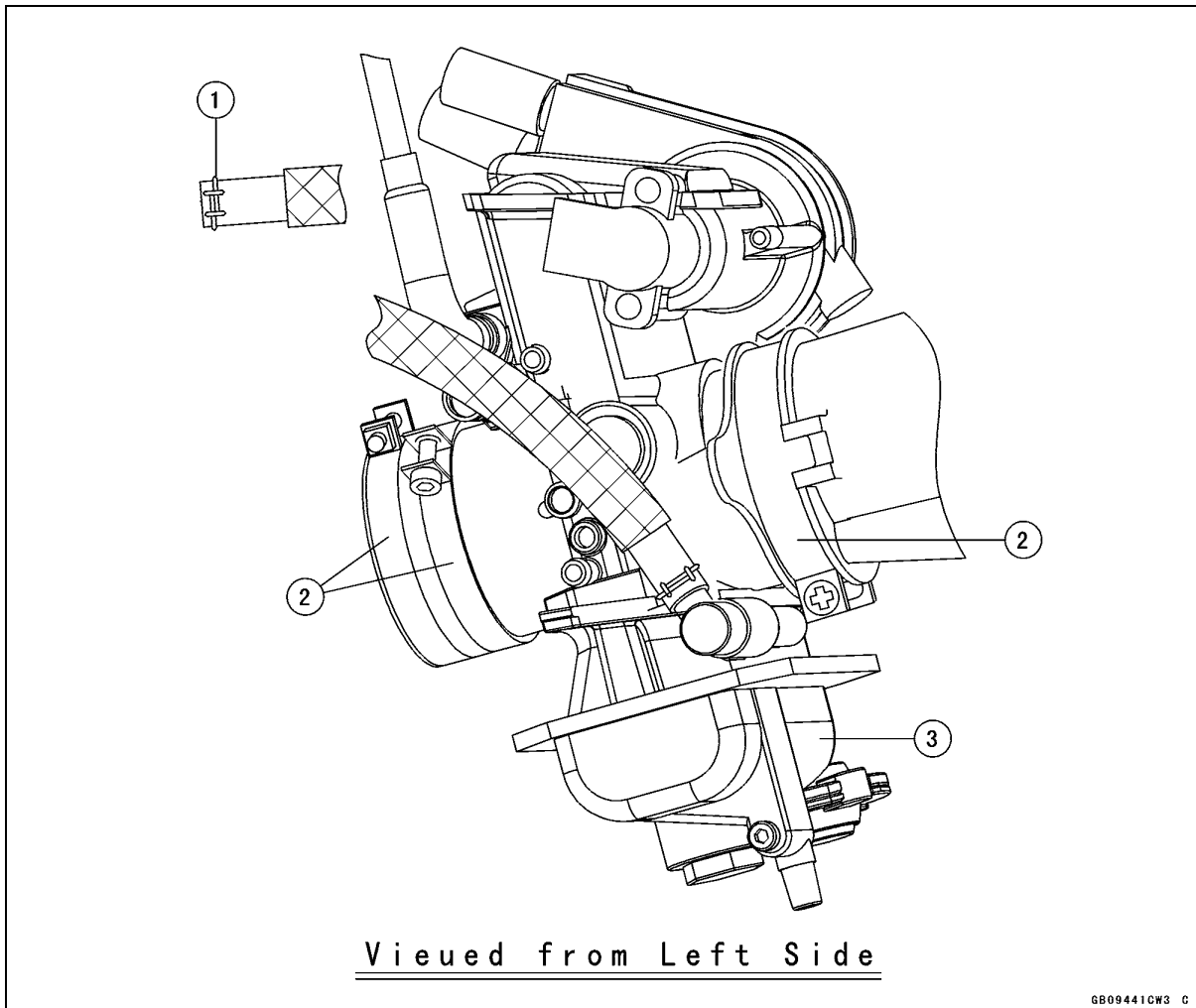
Cable, Wire, and Hose Routing

1. Install the clamps as shown in the figure.
2. Clamps (Install the clamp screws as shown in the figure.)
3. Carburetor

17-6 APPENDIX

Cable, Wire, and Hose Routing

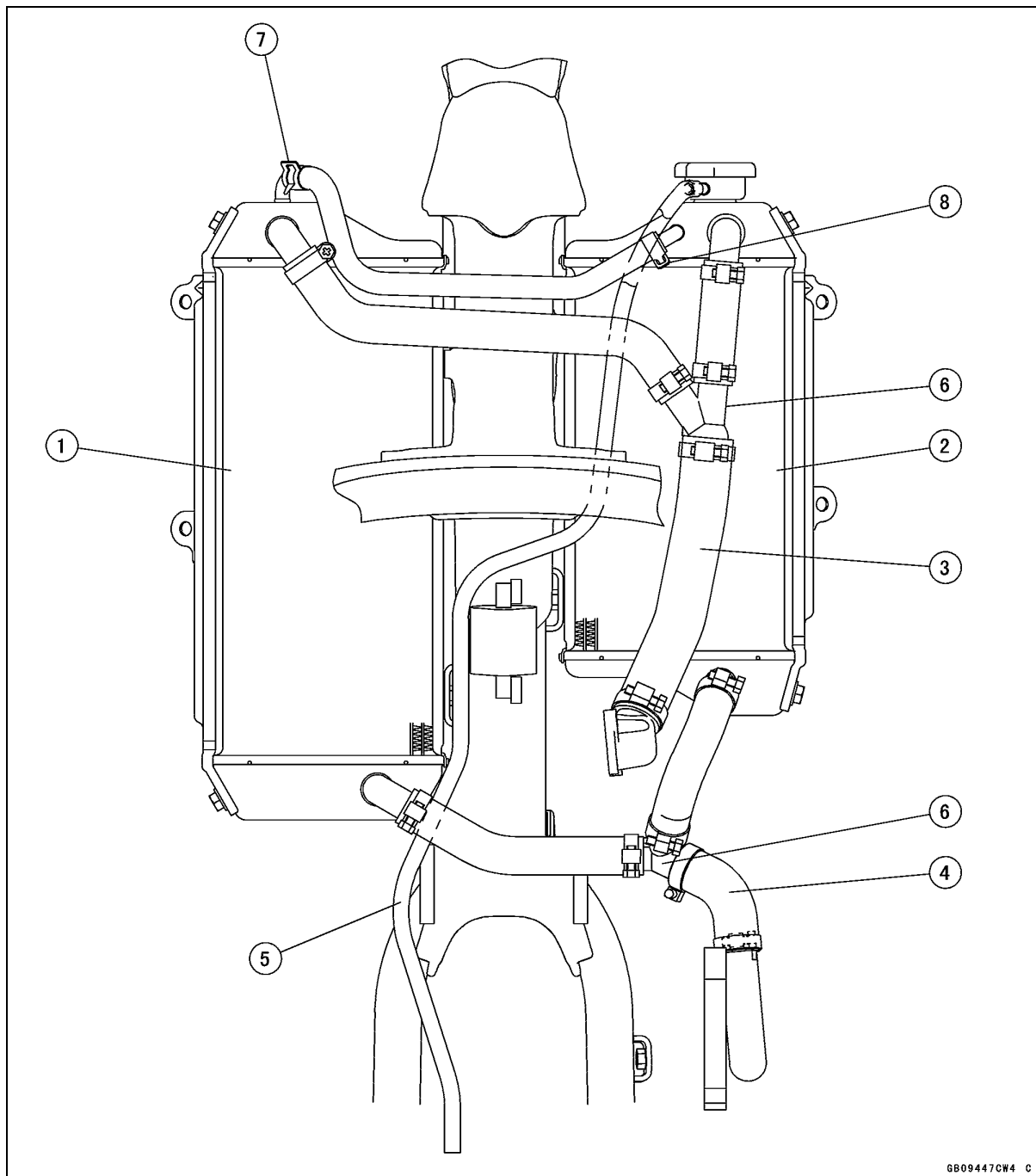

1. Left Radiator
2. Right Radiator
3. Water Hose (to cylinder head)
4. Water Hose (to water pump)
5. Radiator Overflow Hose

6. Joint Pipe
7. Clamp (Position the clamp claw to left side.)
8. Clamp (Position the clamp claw downward.)

Cable, Wire, and Hose Routing

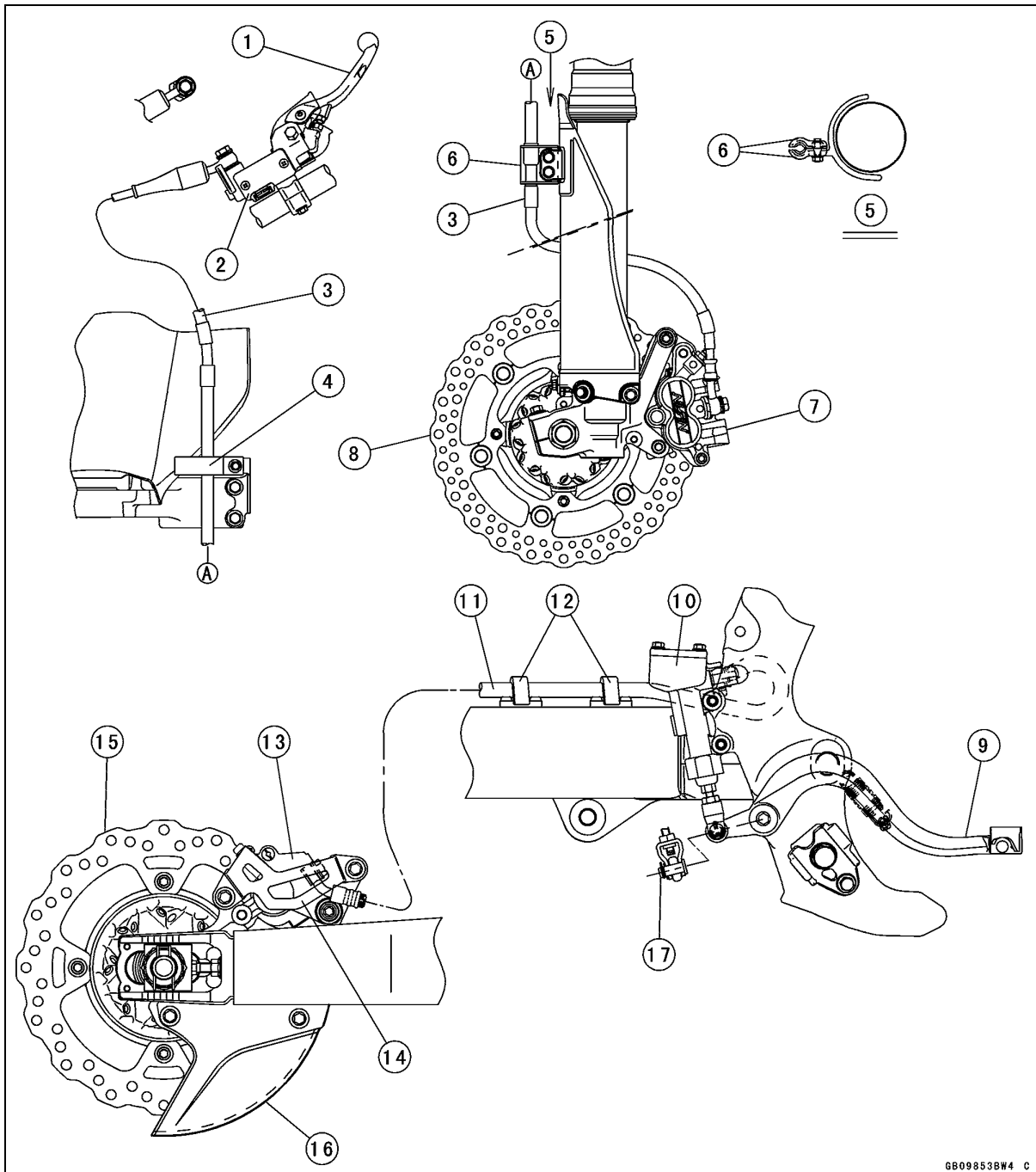

GB098538W4 C

1. Brake Lever
2. Front Brake Master Cylinder
3. Front Brake Hose
4. Clamp
5. Viewed
6. Clamps
7. Front Brake Caliper
8. Front Brake Disc

10. Rear Brake Master Cylinder
11. Rear Brake Hose
12. Clamps
13. Rear Brake Caliper
14. Rear Brake Caliper Guard
15. Rear Brake Disc
16. Rear Brake Disc Guard
17. Cotter Pin

17-8 APPENDIX

Troubleshooting Guide

This is not an exhaustive list, giving every possible cause for each problem listed. It is meant simply as a rough guide to assist the troubleshooting for some of the more common difficulties.

Engine Doesn't Start, Starting Difficulty:

Engine won't turn over:

- Valve seizure
- Valve lifter seizure
- Cylinder, piston seizure
- Crankshaft seizure
- Connecting rod small end, big end seizure
- Transmission gear or bearing seizure
- Camshaft seizure
- Kick shaft return spring broken
- Kick ratchet gear not engaging

No fuel flow:

- No fuel in tank
- Fuel tank cap air vent obstructed
- Fuel tap clogged
- Fuel tap turned off
- Fuel line clogged
- Carburetor float valve clogged

Engine flooded:

- Fuel level in carburetor float bowl too high
- Float valve worn or jammed with foreign matter
- Starting technique faulty (When flooded, crank the engine with the hot start opened to allow more air to reach the engine.)

Fuel/air mixture incorrect:

- Pilot screw and/or idle adjusting screw maladjusted
- Pilot jet or air passage clogged
- Air cleaner clogged, poorly sealed, or missing
- Starter jet clogged

No spark; spark weak:

- Spark plug dirty, broken, or gap maladjusted
- Spark plug cap or high tension wiring trouble
- Spark plug cap shorted or not in good contact
- Spark plug incorrect heat value
- Faulty CDI unit
- Crankshaft sensor trouble
- Ignition coil trouble
- Engine stop switch shorted
- Neutral switch trouble.
- Wiring shorted or open
- Flywheel damage

Compression Low:

- Spark plug loose

- Cylinder head not sufficiently tightened down
- No valve clearance
- Cylinder, piston worn
- Piston ring bad (worn, weak, broken, or sticking)
- Piston ring/groove clearance excessive
- Cylinder head gasket damaged
- Cylinder head warped
- Valve spring broken or weak
- Valve not seating properly (valve bent, deformed, worn, or carbon accumulation on the seating surface)
- Decompression trouble

Poor Running at Low Speed:

Spark weak:

- Spark plug dirty, broken, or gap maladjusted
- Spark plug cap or high tension wiring trouble
- Spark plug cap shorted or not in good contact
- Spark plug incorrect heat value
- Faulty CDI unit
- Crankshaft sensor trouble
- Flywheel damaged
- Ignition coil trouble
- Wiring connector not in good contact

Fuel/air mixture incorrect:

- Pilot screw maladjusted
- Pilot jet, or air passage clogged
- Needle Jet, or air passage clogged
- Air cleaner clogged, poorly sealed, or missing
- Choke plunger stuck open
- Hot starter plunger stuck open
- Fuel level in carburetor float bowl too high or too low
- Fuel tank cap air vent obstructed
- Fuel tap clogged
- Carburetor holder loose
- Air cleaner duct loose

Compression low:

- Spark plug loose
- Cylinder head not sufficiently tightened down
- No valve clearance
- Cylinder, piston worn
- Piston ring bad (worn, weak, broken, or sticking)
- Piston ring/groove clearance excessive
- Cylinder head gasket damaged
- Cylinder head warped
- Valve spring broken or weak

Troubleshooting Guide

Valve not seating properly (valve bent, deformed, worn, or carbon accumulation on the seating surface)

Decompression trouble

Other:

Faulty CDI unit
 Engine oil level too high
 Engine oil viscosity too high
 Brake dragging
 Drive train trouble
 Engine overheating
 Clutch slipping

Poor Running or No Power at High Speed:

Firing incorrect:

Spark plug dirty, broken, or gap maladjusted
 Spark plug cap or high tension wiring trouble
 Spark plug cap shorted or not in good contact
 Spark plug incorrect heat value
 Faulty CDI unit
 Crankshaft sensor trouble
 Flywheel damage
 Ignition coil trouble
 Wiring connector not in good contact

Fuel/air mixture incorrect:

Choke plunger stuck open
 Hot starter plunger stuck open
 Main jet clogged or wrong size
 Jet needle or needle jet worn
 Air jet clogged
 Fuel level in carburetor float bowl too high or too low
 Needle Jet, or air passage clogged
 Air cleaner clogged, poorly sealed, or missing
 Air cleaner duct loose
 Water or foreign matter in fuel
 Carburetor holder loose
 Fuel tank cap air vent obstructed
 Fuel tap clogged
 Fuel line clogged

Compression low:

Spark plug loose
 Cylinder head not sufficiently tightened down
 No valve clearance
 Cylinder, piston worn
 Piston ring bad (worn, weak, broken, or sticking)
 Piston ring/groove clearance excessive
 Cylinder head gasket damaged
 Cylinder head warped
 Valve spring broken or weak

Valve not seating properly (valve bent, deformed, worn, carbon accumulation on the seating surface.)

Decompression trouble

Knocking:

Carbon built up in combustion chamber
 Fuel poor quality or incorrect
 Spark plug incorrect heat value
 Faulty CDI unit

Other:

Throttle valve won't fully open
 Brake dragging
 Air cleaner clogged
 Water or foreign matter in fuel
 Clutch slipping
 Overheating
 Engine oil level too high
 Engine oil viscosity too high
 Drive train trouble
 Crankshaft bearing worn or damage

Engine Overheating:

Firing incorrect:

Spark plug dirty, broken, or maladjusted
 Spark plug incorrect
 Faulty CDI unit

Fuel/air mixture incorrect:

Main jet clogged or wrong size
 Fuel level in carburetor float bowl too low
 Carburetor holder loose
 Air cleaner clogged, poorly sealed, or missing
 Air cleaner duct loose
 Hot starter plunger stuck open

Compression high:

Carbon built up in combustion chamber

Engine load faulty:

Clutch slipping
 Engine oil level too high
 Engine oil viscosity too high
 Brake dragging
 Drive train trouble

Lubrication inadequate:

Engine oil level too low
 Engine oil poor quality or incorrect

Coolant incorrect:

Coolant level too low
 Coolant deteriorated

Cooling system component incorrect:

Radiator clogged
 Radiator cap trouble
 Water pump not rotating

Clutch Operation Faulty:

Clutch slipping:

No clutch lever play
 Clutch cable maladjusted

17-10 APPENDIX

Troubleshooting Guide

- Clutch inner cable sticking
- Friction plate worn or warped
- Steel plate worn or warped
- Clutch spring broken or weak
- Clutch release function trouble
- Clutch hub or housing unevenly worn

Clutch not disengaging properly:

- Clutch lever play excessive
- Clutch spring compression uneven
- Engine oil deteriorated
- Engine oil viscosity too high
- Engine oil level too high
- Clutch housing seized
- Clutch release function trouble
- Clutch hub nut loose
- Clutch plate warped or rough
- Clutch hub spline damaged

Gear Shifting Faulty:

Doesn't go into gear; shift pedal doesn't return:

- Clutch not disengaging
- Shift fork bent, worn, or seized
- Shift return spring pin loose
- Shift return spring weak or broken
- Shift shaft lever broken
- Pawl guide plate broken
- Shift pawl broken
- Shift pawl spring tension lose
- Gear seized
- Gear set lever operation trouble
- Shift drum broken

Jumps out of gear:

- Shift fork ear worn, bent
- Gear groove worn
- Gear dogs and/or dog holes worn
- Shift drum groove worn
- Gear set lever spring weak or broken
- Shift fork guide pin worn
- Drive shaft, output shaft, and/or gear splines worn

Overshifts:

- Gear set lever spring weak or broken
- Pawl guide plate worn

Abnormal Engine Noise:

Knocking:

- Faulty CDI unit
- Carbon built up in combustion chamber
- Fuel poor quality or incorrect
- Spark plug incorrect heat value
- Overheating

Piston slap:

- Cylinder/piston clearance excessive
- Cylinder, piston worn
- Connecting rod bent
- Piston pin, piston pin hole worn

Valve noise:

- Valve clearance incorrect
- Valve spring broken or weak
- Camshaft bearing or cam face worn
- Valve lifter worn

Other noise:

- Connecting rod big end, small end clearance excessive
- Piston ring worn, broken, or stuck
- Piston seizure, damage
- Cylinder head gasket leaking
- Exhaust pipe leaking at cylinder head connection
- Crankshaft runout excessive
- Engine mounts loose
- Crankshaft bearing worn
- Camshaft chain tensioner trouble
- Camshaft chain, sprocket, chain guide worn
- Primary gear worn or damaged
- Decompressor spring broken
- Magneto flywheel loose

Abnormal Drive Train Noise:

Clutch noise:

- Clutch housing finger and friction plate tang worn
- Clutch housing gear worn
- Metal chips jammed in clutch housing gear teeth

Transmission noise:

- Bearings worn
- Transmission gears worn or chipped
- Metal chips jammed in gear teeth
- Engine oil insufficient, low viscosity
- Kick ratchet gear not properly disengaging from kick gear
- Kick shaft idle gear worn or chipped

Drive chain noise:

- Drive chain maladjusted
- Drive chain worn
- Rear and/or engine sprocket worn
- Drive chain lubrication insufficient
- Rear wheel misaligned

Abnormal Frame Noise:

Front fork noise:

- Oil insufficient or too thin
- Spring weak or broken
- Front fork air pressure high

Rear shock absorber noise:

- Shock absorber trouble
- Spring weak or broken

Disc brake noise:

- Pad surface glazed
- Disc warped
- Caliper trouble
- Pad installed incorrectly

Troubleshooting Guide

Master cylinder damaged

Other noise:

Bracket, nut, bolt, etc., not properly mounted or tightened

Abnormal Exhaust Color:

White smoke:

Piston oil ring worn
Cylinder worn
Valve oil seal damaged
Valve guide worn
Engine oil level too high

Black smoke:

Air cleaner element clogged
Main jet too large or fallen off
Choke plunger stuck open
Fuel level in carburetor float bowl too high

Brown smoke:

Main jet too small
Fuel level in carburetor float bowl too low
Air cleaner duct loose
Air cleaner poorly sealed or missing

Handling and/or Stability

Unsatisfactory:

Handlebar hard to turn:

Cable, hose, wire routing incorrect
Steering stem nut too tight
Steering stem bearing damaged
Steering stem bearing lubrication inadequate
Steering stem bent
Tire air pressure too low

Handlebar shakes or excessively vibrates:

Tire worn
Swingarm pivot bearings worn
Rim warped, or not balanced
Spokes loose

Wheel bearing worn
Handlebar clamp bolt loose
Steering stem head bolt loose
Front, rear axle runout excessive

Handlebar pulls to one side:

Frame bent
Rear wheel misalignment
Swingarm bent or twisted
Swingarm pivot shaft bent
Steering maladjusted
Steering stem bent
Front fork bent
Right and left front fork oil level uneven

Suspension operation trouble:

(Too hard)

Tire air pressure too high
Front fork oil excessive
Front fork oil viscosity too high
Rear shock absorber adjustment too hard
Front fork bent
Front fork air pressure too high

(Too soft)

Front fork oil insufficient or leaking
Front fork oil viscosity too low
Rear shock absorber adjusted too soft
Front fork, rear shock absorber spring weak
Rear shock absorber oil or gas leaking
Tire air pressure too low

Brake Doesn't Hold:

Air in brake system
Pad, disc worn
Brake fluid leakage
Contaminated pad
Brake fluid deteriorated
Brake master cylinder cups damaged
Master cylinder scratched inside
Disc warped

MODEL APPLICATION

Year	Model	Beginning Frame No.
2006	KX450D6F	JKAKXGDC□6A000001 or JKAKX450DDA000001
2007	KX450D7F	JKAKXGDC□7A012001 or JKAKX450DDA012001
2008	KX450D8F	JKAKXGDC□8A021001 or JKAKX450DDA021001

□: This digit in the frame number changes from one machine to another.



KAWASAKI HEAVY INDUSTRIES, LTD.
Consumer Products & Machinery Company

Part No.99924-1355-03

Printed in Japan