



XTRAINER 250 2T EUROPA - XTRAINER 300 2T EUROPA XTRAINER 250 2T - XTRAINER 300 2T

Thanks for your preference, and have a good time! This handbook contains the information you need to properly operate and maintain your motorcycle.

The data, specifications and images shown in this manual does not constitute an engagement on the part of BETAMOTOR S.p.A. BETAMOTOR reserves the right to make any changes and improvements to its models at any moment and without notice.

Code 036.44.044.83.00

IMPORTANT

We recommend you to check all the tightenings after the first one or two hours' ride over rough ground. Special attention should be paid to the following parts:

- rear sprocket
- ensure that the footrests are properly fixed
- front/rear brake levers/calipers/discs
- check that the plastics are properly fastened
- engine bolts
- shock absorber bolts/swingarm
- wheel hubs/spokes
- rear frame
- pipe connections
- tensioning the chain

IMPORTANT

In the event of interventions on the vehicle, contact Betamotor after-sales service.

CONTENTS	
Operating instructions.....	5
Symbols.....	5
Riding safety	6
CHAPTER 1 GENERAL INFORMATION	7
Vehicle identification data	8
Tools kit	8
Familiarizing with the vehicle.....	9
Specifications	10
Electrical system.....	14
Bulbs	16
Fuses	16
Recommended lubricants and liquid	16
CHAPTER 2 OPERATION	17
Main parts	18
Dashboard operating instructions	23
Checks before and after use	32
Running in.....	32
Refuelling	33
Oil mixer refuelling	34
Starting the engine	34
Engine shut-down	34
CHAPTER 3 ADJUSTMENTS	35
Key to symbols.....	36
Brakes	36
Clutch.....	37
Adjustment of gas clearance.....	37
Adjusting the idle speed.....	37
Exhaust valve control adjustment	41
Handlebar adjustment	41
Adjusting fork	42
Shock absorber.....	43
CHAPTER 4 CHECKS AND MAINTENANCE	45
Key to symbols.....	46
Engine oil.....	46
Liquid coolant.....	47

Air filter	50
Spark plug	51
Carburettor	52
Front brake.....	54
Rear brake	57
Clutch control	60
Check and adjusting of steering play.....	62
Front wheel	63
Fork.....	64
Rear suspension leverage.....	64
Tyres.....	65
Chain	65
Headlight.....	67
Replacing the headlight bulbs.....	67
Tail light.....	68
Battery.....	68
Fuses	70
Cleaning the vehicle.....	71
Electrical connector maintenance	72
Prolonged inactivity.....	73
Scheduled maintenance vehicle	74
Tightening torque overview	76
CHAPTER 5 REPLACEMENTS	77
Removal and refitting of the saddle.....	78
Removing and installing air filter cover panel.....	79
Removing and installing the headlamp mask	80
CHAPTER 6 TROUBLESHOOTING	81
Troubleshooting	82
CHAPTER 7 INSTRUCTIONS FOR PERIODIC INSPECTION WORKSHOPS	83
Instructions for periodic inspection workshops.....	84

OPERATING INSTRUCTIONS

- The vehicle must be accompanied by: number-plate, registration document, tax disc and insurance.
- Any modifications of the engine or other parts are punishable by severe sanctions including the confiscation of the vehicle.
- To protect your safety and that of others, always drive carefully and with your helmet on and always keep low beams on.
- Do not sit on the vehicle when it is on its stand.
- Do not start the engine in closed places.

WARNING

Any modifications and tampering with the vehicle during the warranty period exempt the manufacturer from all responsibility and invalidate warranty.

SYMBOLS



SAFETY/ATTENTION

Failure to respect information marked with this symbol can entail a personal hazard.



INTEGRITY OF THE VEHICLE

Failure to respect information marked with this symbol can entail serious damage to the vehicle and termination of the warranty.



FLAMMABLE LIQUID HAZARD



Read the use and maintenance manual carefully.



MANDATORY TO WEAR PROTECTIVE CLOTHING

Use of the vehicle is subject to wearing specific protective clothing and safety footwear.



PROTECTIVE GLOVES MANDATORY

To perform the operations described, it is mandatory to wear protective gloves.



FORBIDDEN TO USE NAKED FLAMES OR POSSIBLE UNCONTROLLED IGNITION SOURCES



NO SMOKING



DO NOT USE MOBILE PHONE



CORROSIVE SUBSTANCES HAZARD

Liquids marked with this symbol are highly corrosive: handle with care



POISONING HAZARD

RIDING SAFETY

- Observe the Highway Code.
- Always wear approved personal protective equipment.
- Always ride with the low beam on.
- Always keep the crash helmet visor clean.
- Avoid wearing garments with hanging ends.
- Do not keep sharp or brittle objects in your pockets while riding.
- Properly adjust the rearview mirrors.
- Always ride in a seated position, with both hands on the handlebars and both feet on the footrests.
- Never ride abreast with other vehicles.
- Do not tow and avoid being towed by other vehicles.
- Always keep a safe distance from other vehicles.
- Do not start off while the vehicle is on its stand.
- Avoid swaying and wheelies as they are extremely dangerous for your own and other people's safety as well as for your vehicle.
- Always apply both brakes on dry roads with no gravel and sand. Using one brake may be dangerous and cause uncontrolled skidding.
- To reduce the braking distance, always apply both brakes.
- On wet roads and in off-road riding, drive with care and at moderate speed. Take special care in applying the brakes.

CHAPTER 1 GENERAL INFORMATION

CONTENTS

Vehicle identification data	8
Frame identification	8
Engine identification	8
Tools kit	8
Familiarizing with the vehicle.....	9
Main parts:.....	9
Specifications	10
Weight.....	10
Dimensions	10
Tyres	10
Wheels	10
Capacities	10
Front suspension.....	11
Rear suspension	11
Front brake.....	11
Rear brake	11
Engine	12
Electrical system.....	14
Electrical diagram	14
Legend electrical diagram	15
Bulbs	16
Fuses	16
Recommended lubricants and liquid	16

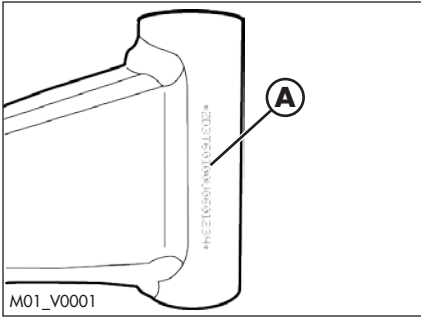

VEHICLE IDENTIFICATION DATA

FRAME IDENTIFICATION

Frame identification data **A** are stamped on the right side of the steering head tube.

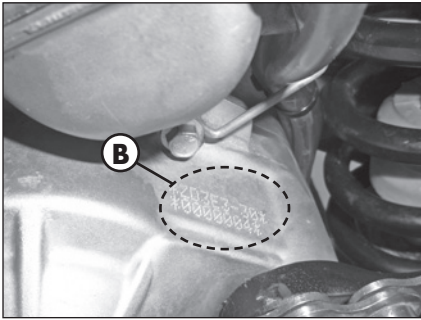

ENGINE IDENTIFICATION

Engine identification data **B** are stamped in the area shown in the figure.

TOOLS KIT

The following items are supplied as standard: operation, maintenance manual, tool kit and the cable adapter to connect the CAN socket to a scantool.

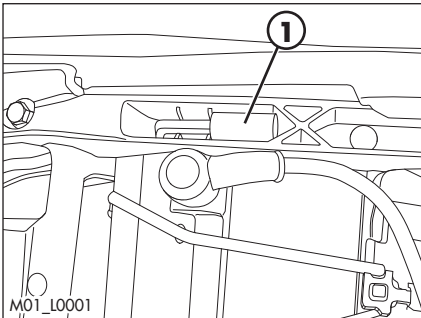

Inside the battery compartment you will find the hexagon wrench 3 and the socket wrench (8 mm). To gain access remove the saddle (page 78).

FAMILIARIZING WITH THE VEHICLE

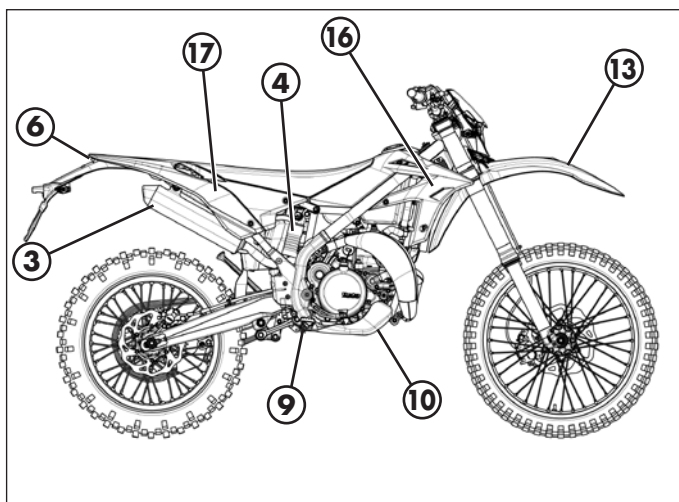
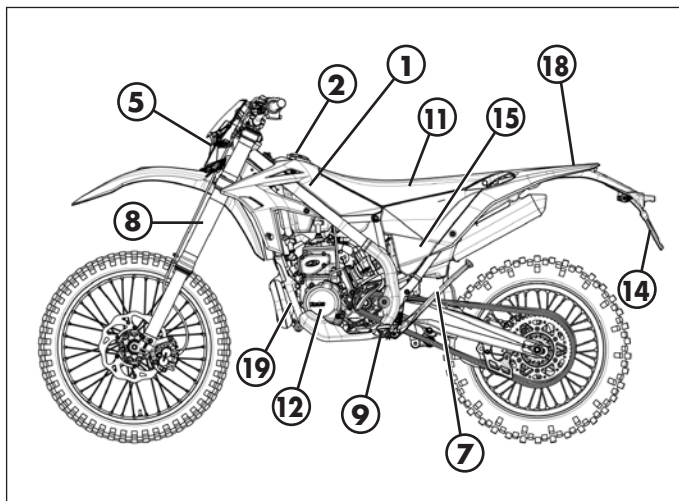

MAIN PARTS:

- | | | |
|-------------------------|-------------------------------------|------------------------|
| 1 - Fuel tank | 10 - Lower bumper
(Bumper kit) | 17 - Rear side panel |
| 2 - Tank cap | 11 - Saddle | 18 - Rear mudguard |
| 3 - Silencer | 12 - Engine | 19 - Carbon Canister * |
| 4 - Rear shock absorber | 13 - Front mudguard | |
| 5 - Headlight | 14 - Number-plate holder | |
| 6 - Rear light | 15 - Side panel air filter
cover | |
| 7 - Side stand | 16 - Front side panel | |
| 8 - Fork | | |
| 9 - Rider's footrests | | |

* For markets where required

SPECIFICATIONS

WEIGHT

Weight in running order with full fuel and optional
 115 kg (front 55 Kg; rear 60 Kg)

DIMENSIONS

maximum length (with plate holder) 2270 mm
 maximum width 802 mm
 overall height 1245 mm
 wheelbase..... 1467 mm
 saddle height..... 910 mm
 ground clearance..... 320 mm
 footrest height..... 390 mm

TYRES

Dimensions		Pressure [Bar]	
Front tyre	Rear tyre	Front tyre	Rear tyre
80/100-21	140/80-18	1,5 (road use)	1,8 (road use)
		1 (off-road use)	1 (off-road use)

WHEELS

Version	Dimensions	
	Front	Rear
Xtrainer 250 - 300	J 1.6x21	J 1.85x18

CAPACITIES

fuel tank.....8,5 liters
 including reserve..... 1,5 liters
 coolant circuit..... 1,3 liters
 mixer oil tank0,55 liters
 including reserve.....0,21 liters
 gear oil.....0,85 liters

FRONT SUSPENSION

Hydraulic fork USD (shafts Ø43 mm)

Spring	K 8
Oil type	see table "Recommended lubricants and liquids", page 16
Oil quantity	500 ml
Spring preload register	completely open
Rebound clicks (from completely closed).....	12
Wheel travel.....	270 mm

REAR SUSPENSION

Single shock absorber with compound lever

Spring	K 5,2
Static sag load (see page 44).....	22 mm
Compression clicks, high speeds (from completely closed).....	15
Rebound clicks (from completely closed).....	10
Shock absorber travel.....	110 mm

FRONT BRAKE

Ø260 mm disc and dual-piston floating caliper

REAR BRAKE

Ø240 mm disc and single-piston floating caliper

1

ENGINE

Version	XTRAINER 250 2T Europa XTRAINER 250 2T	XTRAINER 300 2T Europa XTRAINER 300 2T
Type	Single-cylinder, 2-stroke, liquid cooled and electric start	
Bore x stroke [mm]	66,4 x 72	73 x 69,9
Displacement [cm ³]	249	292,6
Compression ratio	13,5:1	11,55:1
CO ₂ [g/km] * #	56	64
Fuel consumption [l/100km] * #	2,4	2,8

* Only valid for EUROPA version

WMTc cycle related data, for class L vehicles

Fuel system.....carburettor with electronic mixer

Carburettor

Version	XTRAINER 250 2T Europa	XTRAINER 250 2T	XTRAINER 300 2T Europa	XTRAINER 300 2T
Main jet	130	155	130	155
Slow jet	38	38	38	38
Start jet	50	85	50	85
Needle	N84K	NOZK	N84H	NOZJ
Needle position (from top)	2°	3°	1°	2°
Air screw turns (from all closed)	2	1 + 1/4	1 + 1/2	1 + 1/2
Valve	7,5	7,5	7,5	7,5

Cooling system forced liquid circulation by pump

Spark plugNGK IR GR7CI-8

Clutch..... wet, multidisc

Gearchange

Version	XTRAINER 250 2T Europa	XTRAINER 250 2T	XTRAINER 300 2T Europa	XTRAINER 300 2T
Primary drive	27/72	27/72	27/72	27/72
Gear ratio 1 st gear	12/31	12/31	12/31	12/31
Gear ratio 2 nd gear	15/28	15/28	15/28	15/28
Gear ratio 3 rd gear	19/28	19/28	19/28	19/28
Gear ratio 4 th gear	20/24	20/24	20/24	20/24
Gear ratio 5 th gear	27/27	27/27	27/27	27/27
Gear ratio 6 th gear	28/24	28/24	28/24	28/24
Final drive	15/42	13/49	15/42	14/49

Exhaust valve.....centrifugal operation with reaction springs

Ignition DC-CDI without trembler,
with digital variable spark advance

Starting.....electric starter (Kick-starter optional)

ELECTRICAL SYSTEM

ELECTRICAL DIAGRAM

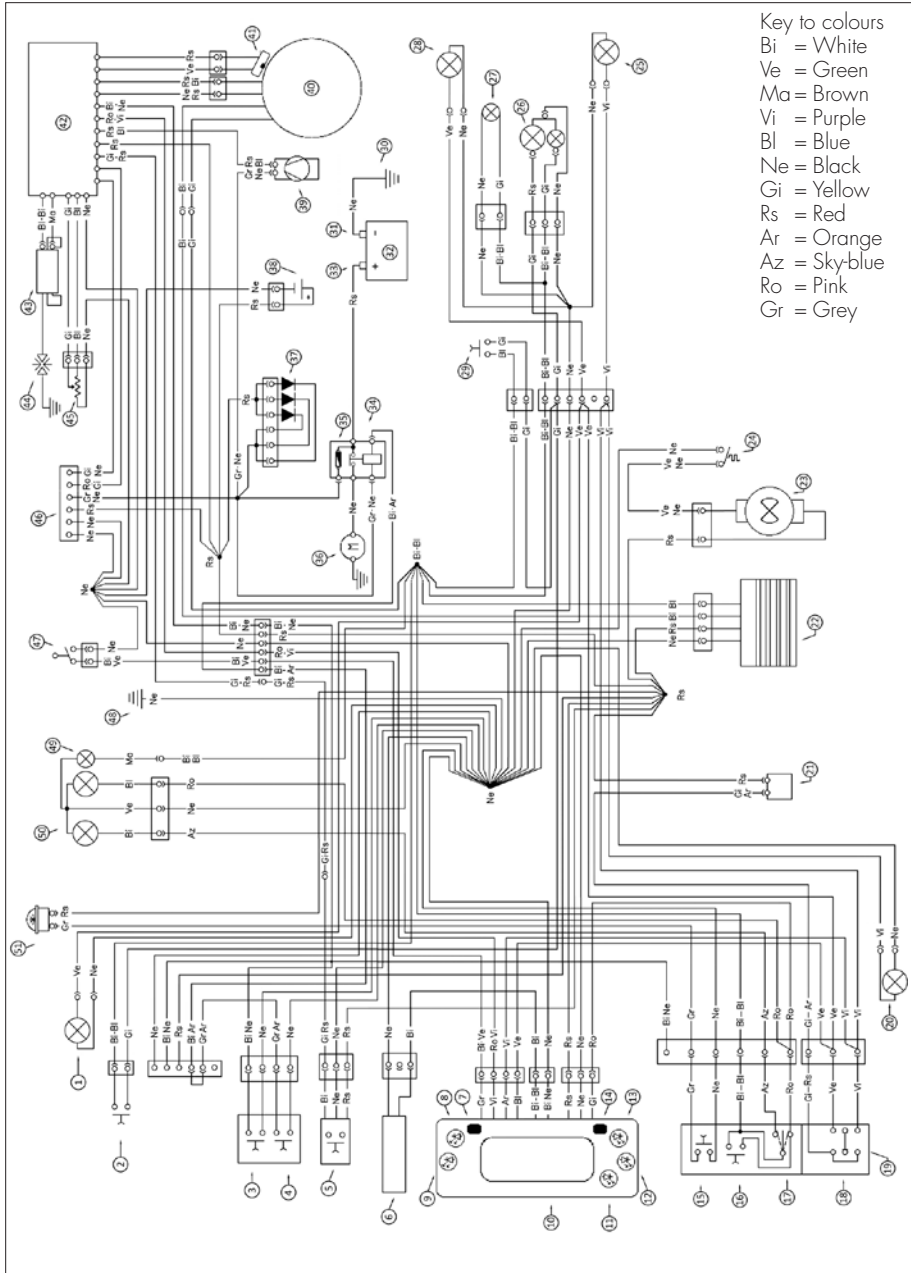

- Key to colours
 Bi = White
 Ve = Green
 Ma = Brown
 Vi = Purple
 Bl = Blue
 Ne = Black
 Gi = Yellow
 Rs = Red
 Ar = Orange
 Az = Sky-blue
 Ro = Pink
 Gr = Grey

LEGEND ELECTRICAL DIAGRAM

- 1) RIGHT HAND FRONT TURN INDICATOR 12V 6W
- 2) FRONT BRAKE LIGHT SWITCH
- 3) ENGINE STOP PUSH-BUTTON
- 4) ENGINE START PUSH-BUTTON
- 5) MAP SWITCH
- 6) WHEEL REVOLUTION SENSOR
- 7) ADJUST PUSH-BUTTON
- 8) OIL MIX SYSTEM DIAGNOSIS WARNING LIGHT
- 9) RIGHT TURN INDICATORS WARNING LIGHT
- 10) DASHBOARD
- 11) HEADLIGHT TELL TALE LAMP
- 12) LEFT TURN INDICATORS WARNING LIGHT
- 13) OIL RESERVE WARNING LIGHT
- 14) SET PUSH-BUTTON
- 15) HORN BUTTON
- 16) FLASH-TO-PASS BUTTON
- 17) HEADLIGHT SELECTOR
- 18) TURN SIGNAL LAMPS SWITCH
- 19) LEFT-HAND CONTROL GROUP
- 20) LEFT-HAND FRONT TURN INDICATOR 12V 6W
- 21) UNIT TURN SIGNAL LAMPS
- 22) VOLTAGE REGULATOR
- 23) ELECTRIC FAN
- 24) THERMOSWITCH
- 25) LEFT-HAND REAR TURN INDICATOR (12V 6W BULB)
- 26) LED TAIL LIGHT
- 27) NUMBER PLATE LIGHT
- 28) RIGHTHAND REAR TURN INDICATOR (12V 6W BULB)
- 29) REAR STOP SWITCH
- 30) FRAME GROUND WIRE
- 31) BATTERY NEGATIVE TERMINAL
- 32) 12V 4AH BATTERY
- 33) BATTERY POSITIVE TERMINAL
- 34) STARTER RELAY
- 35) 10A FUSE
- 36) STARTER MOTOR
- 37) DIODES GROUP
- 38) CAPACITOR 4700 μ F
- 39) OIL PUMP
- 40) STATOR / POWER GENERATOR
- 41) PICK-UP SENSOR
- 42) ELECTRONIC CONTROL UNIT
- 43) COIL
- 44) SPARK PLUG
- 45) TPS
- 46) DIAGNOSIS CONNECTOR
- 47) OIL RESERVE SENSOR
- 48) FRAME GROUND
- 49) PARKING LIGHT (12V 5W BULB)
- 50) FRONT HEADLIGHT (12V-35/35W BULB)
- 51) 12V HORN

1

BULBS

High beam/low beam	HS1 12V - 35/35W
Parking/daytime	12V - W5W
Turn indicators	12V - H6W
License plate light.....	12V - W5W

FUSES

Two, one of them spare 10A

RECOMMENDED LUBRICANTS AND LIQUID

To maximize the vehicle's performance and ensure many years of trouble-free operation, we recommend using the following products:

PRODUCT TYPE	SPECIFICATIONS
FUEL	GASOLINE  95 RON
OIL MIXER TANK	LIQUI MOLY 2-STROKE MOTOR OIL, SELF-MIXING
GEAR AND CLUTCH OIL	LIQUI MOLY RACING SYNTH 10W50
BRAKE OIL	LIQUI MOLY BRAKE FLUID DOT 5.1
CLUTCH ACTUATOR OIL	LIQUI MOLY BRAKE FLUID DOT 5.1
FORK OIL	SAE 15W
TIE ROD GREASE	LIQUI MOLY SCHMIERFIX
LIQUID COOLANT	LIQUI MOLY COOLANT READY MIX RAF 1 2 PLUS

Note:

It is essential that all renewals should be performed with the products listed in the table above.

CHAPTER 2 OPERATION

CONTENTS

Main parts	18
Fuel tank cap	18
Fuel cock	18
Starter	19
Mixer oil tank cap	19
Clutch lever	19
LH switch	20
RH switch	20
Front brake lever and gas control	20
Gear change lever	21
Brake pedal	21
Kickstart - optional	21
Side stand	21
Keys	22
Steering lock	22
Dashboard operating instructions	23
Main parts	23
Warning lights	24
Battery replacement	25
Adjust button function instruction	26
Select button function instruction	27
To Enter the Setting Mode	28
Checks before and after use	32
Running in	32
Refuelling	33
Oil mixer refuelling	34
Starting the engine	34
Engine shut-down	34

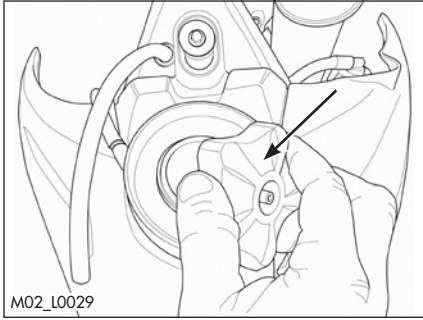

MAIN PARTS

FUEL TANK CAP

To open the fuel tank cap, turn it anticlockwise.

To close the fuel tank cap, set it on the tank and screw it clockwise.

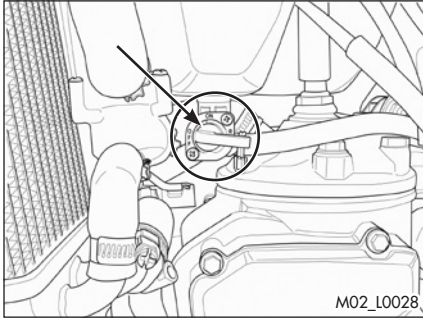

FUEL COCK

Fuel cock has three positions:

OFF: fuel supply closed. Fuel cannot pass from the tank to the carburettor.

ON: fuel supply enabled. Fuel flows from the tank to the carburettor. The tank empties until it reaches the reserve level.

RES: reserve fuel supply. Fuel flows from the tank to the carburettor and the tank empties completely.

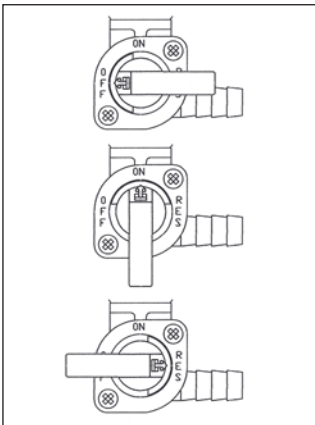

STARTER

The starter lever is located on the carburettor.

To operate the choke pull it upward.

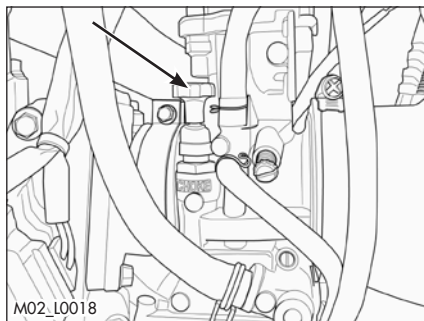

MIXER OIL TANK CAP

The mixer oil tank cap is located under the saddle.

To gain access remove the saddle (page 78).

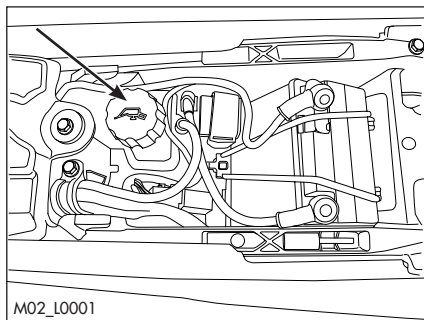

To open the fuel tank cap turn it anticlockwise.

To close the fuel tank cap, set it on the tank and screw it clockwise.

CLUTCH LEVER

Clutch lever is fitted to the left-hand side of the handlebars.

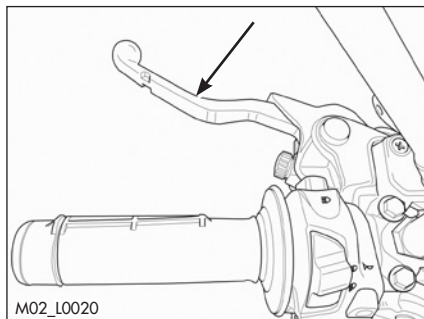

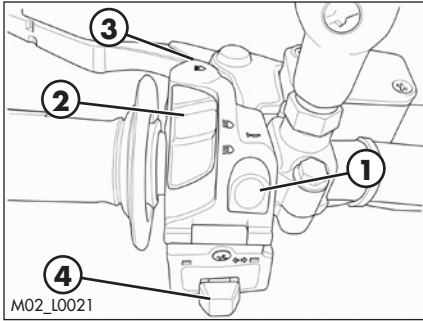

LH SWITCH

The dip and service switch is located on the left side of the handlebar and is composed as follows:

1 - Horn button;

2 - Dip switch:

 parking lights and high beam;

 parking lights and low beam;

3 - Flash-to-pass button;

4 - Turn signal light switch: shifting lever left or right activates the left or right indicators. When released, the lever returns to the central position. Press it to turn the indicators off.

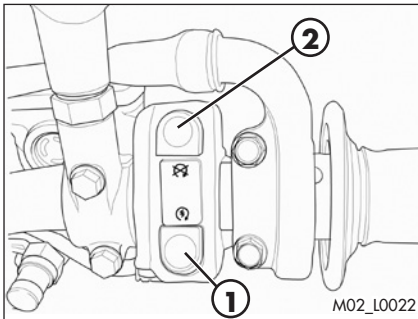

RH SWITCH

Starter button **1** is located on the right-hand side of the handlebars and operate the electric engine starter. For startup, refer to page 34. Do not press the button **1** while the engine is running.

The button **2** turns off the engine.

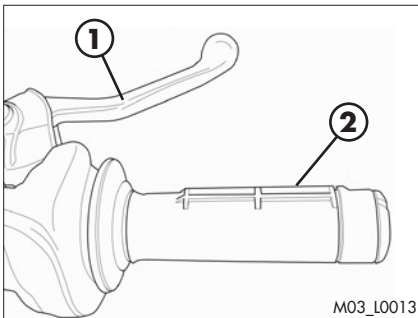

FRONT BRAKE LEVER AND GAS CONTROL

The front brake lever **A** and the gas throttle **B** are located on the right side of the handlebar.

GEAR CHANGE LEVER

Gear change lever is fitted to the left side of the engine.
The positions corresponding to the different gears are shown in the figure.

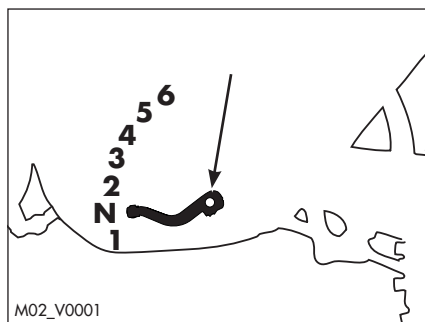

BRAKE PEDAL

Brake pedal is located in front of the right-hand footrest.

The rear brake is operated by pressing down the pedal.

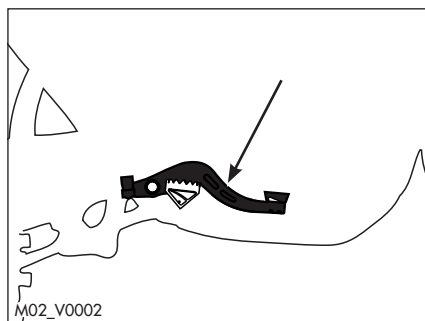

KICKSTART - OPTIONAL

Kickstart is fitted to the right-hand side of the engine.

The upper part of the kickstart can be oriented.

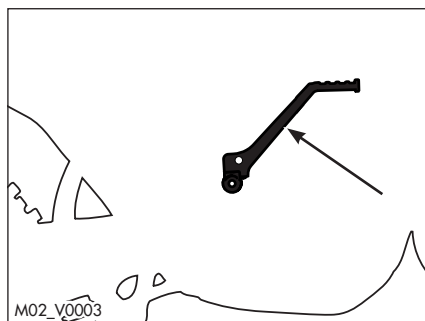

SIDE STAND

Press down side stand with the foot and lean the vehicle against it.
Ensure that the ground is solid and the vehicle stands steadily.

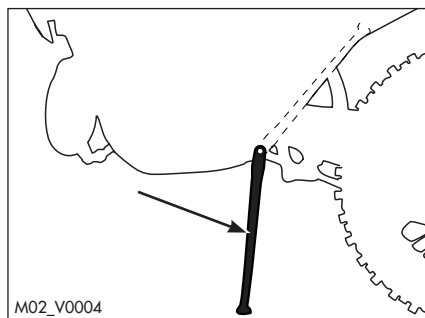

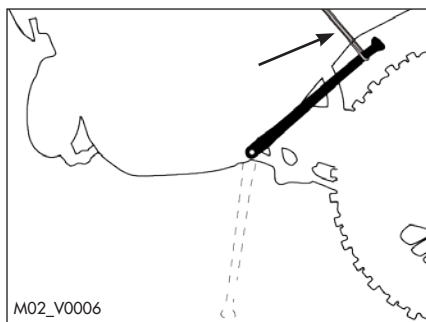

If the vehicle is used off-road, the closed stand can be further fastened by means of rubber band.

KEYS

The vehicle is supplied with two keys (one key and its spare).

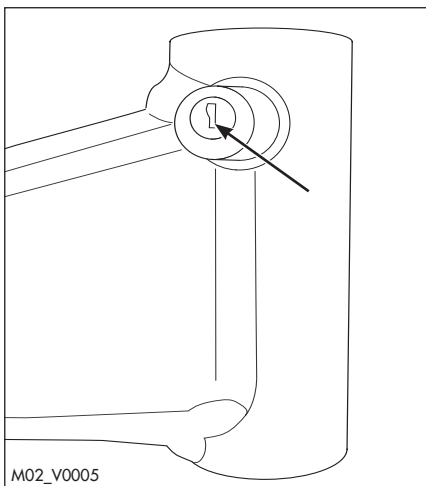

STEERING LOCK

To activate the steering lock:

- turn the handlebar counter-clockwise;
 - push the key and turn counter-clockwise;
- Remove the key from this position.

To deactivate the steering lock:

- turn the key clockwise;
- turn the handlebar clockwise;

From this position, the handlebar is free to move, the key can be removed.

WARNING: do not keep the spare key inside the vehicle, but in a safe place.

We suggest you note the code number stamped on the keys. In this way you can obtain a duplicate.

DASHBOARD OPERATING INSTRUCTIONS

MAIN PARTS

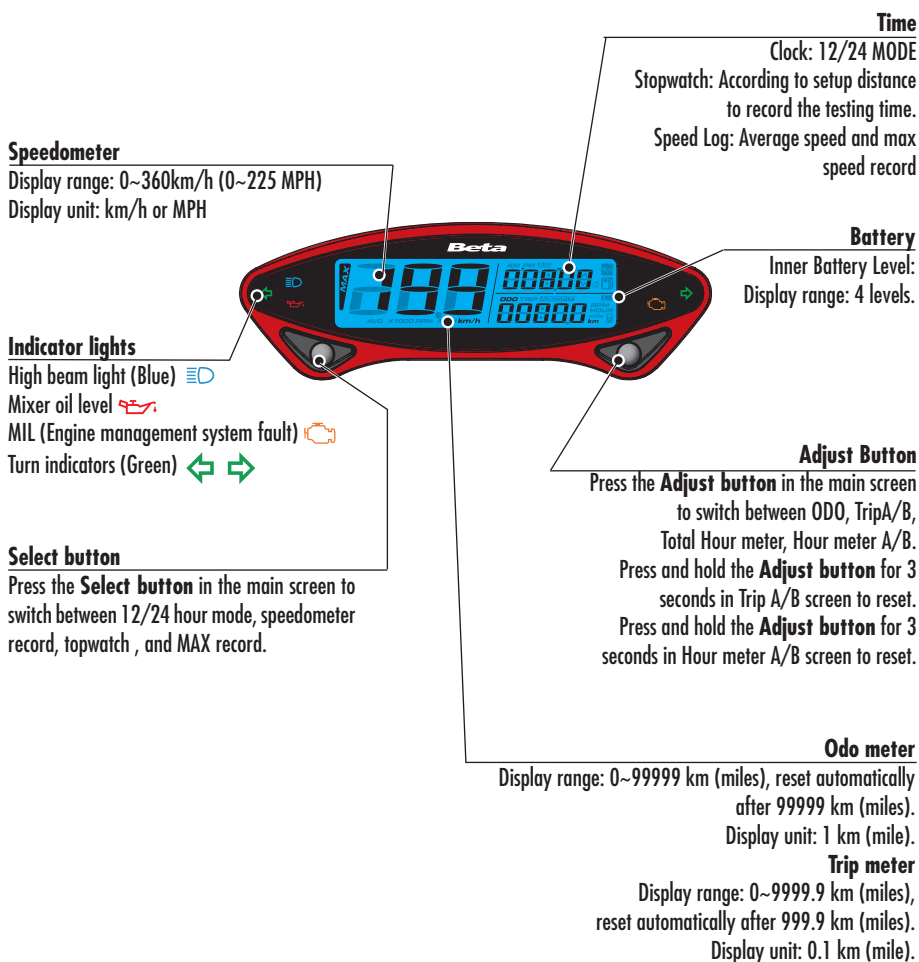

2

WARNING LIGHTS



1 Headlight indicator

The system activates the indicator in synchrony with the activation of the mains beams.

2 Turn indicator lights

The system activates the indicator in synchrony with the activation of the turn indicators.

3 Mixer oil level indicator light

If the warning light comes on, refuel as soon as possible. The mixer tank reserve is indicated on page 10. Refuel with special oil as indicated in the "Table of Lubricants and Recommended Liquids" on page 16.

4 MIL indicator light (Engine management system fault)

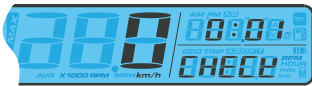

Indicates a fault in the engine management system. Contact as soon as possible an authorized Betamotor.

OPERATION

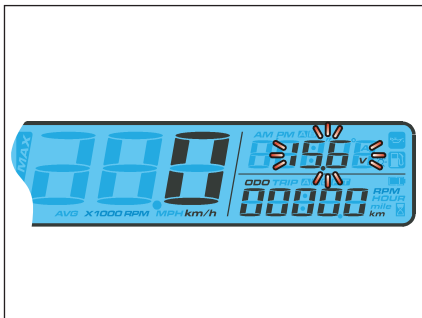

Vehicle battery voltage displaying

When the vehicle is running, the vehicle battery voltage is displayed.

WARNING:

If the voltage value blinks turn off the engine and disconnect the battery as described at page 68.

Contact authorised BETAMOTOR customer service.

BATTERY REPLACEMENT

Follow this procedure for proper installation.

The meter includes an internal battery (CR2032). This battery shall be replaced only when power runs out.

For replacement remove the headlight mask. Remove the battery cover located behind the instrument and pull out the battery.

In order to install the battery properly, push the battery as shown on figure to make sure the battery is placed underneath the metal tab (1).



WARNING:

Not following this procedure could result in permanent damage to the meter.

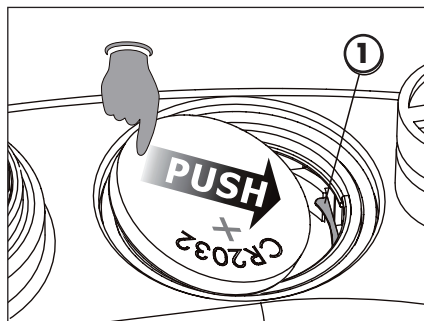
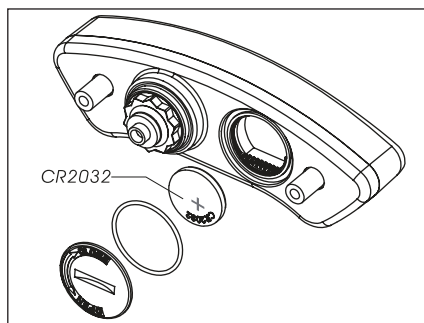

2

ADJUST BUTTON FUNCTION INSTRUCTION

OPERATION

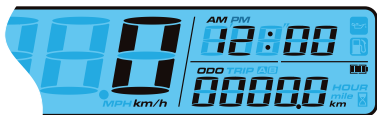

In main screen, press the **Adjust button** once to switch the function from odometer to trip.



In main screen, you could hold pressing the **Adjust button** for 3 seconds to change the speed and space unit, from km / h and km to MPH and mile and vice versa.

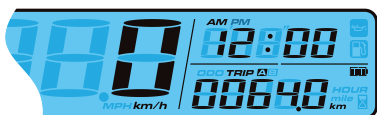

Press the **Adjust button** to switch from trip A to trip B.



Hold pressing the **Adjust button** for 3 seconds to reset the trip A.

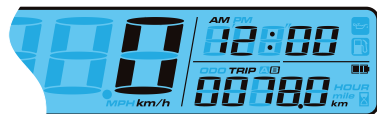

Press the **Adjust button** to switch from trip B to total hour meter.



Hold pressing the **Adjust button** for 3 seconds to reset the trip B.

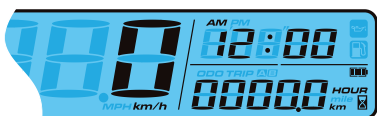

Press the **Adjust button** to switch from total hour meter to hour meter A.



Press the **Adjust button** to switch from hour meter A to hour meter B.



Press and hold the **Adjust button** for 3 seconds to reset the hour meter A.



Press the **Adjust button** to switch from Hour Meter B back to the main screen.

Press and hold the **Adjust button** for 3 seconds to reset the Hour Meter B.

The main screen.

SELECT BUTTON FUNCTION INSTRUCTION

Press the **Select button** during main screen to switch from Clock to Stopwatch.

Press and hold the **Select button** for 3 seconds to change between 12/24hour mode.

NOTE: If 24hour mode is chosen, then the AM/PM symbol will not be displayed.

Press the **Select button** to switch from Stopwatch to Speed Record.

Press and hold the **Select button** for 3 seconds to reset the Stopwatch.

Press the **Select button** to switch from Speed Record back to main screen.

Press and hold the **Select button** for 3 seconds to reset the Speed Record.

NOTE: If Engine Oil Light goes up, reset the Engine Oil Light in this screen to recalculate the mileage.

NOTE: Average speed and the Max speed display in the 3 seconds rotation.

The main screen.

2

TO ENTER THE SETTING MODE

Adjust+SelectX3 function instruction

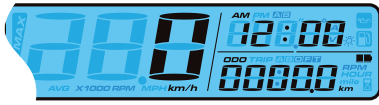

In main screen, press down the Adjust+SelectX3 to enter the tire circumference and sensing point setting (for changing different size tire.)



The tire circumference and sensor point setting.

Press the **Adjust button** to enter the tire circumference setting.

The tire circumference and sensing point setting

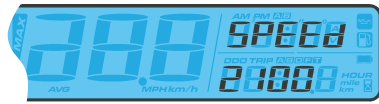

EX. The tire circumference is 2100 mm. Press the **Select button** to change the setting.

NOTE: The tire circumference setting range 2100mm / 1811mm.



EX. The tire circumference setting is changed from 2100mm to 1811mm.

Press **Adjust button** to go back to tire circumferences value setting screen.

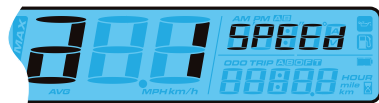

From **a 1** switch to **a 2** screen.

Press the **Adjust button** to enter the clock (Hour) setting.

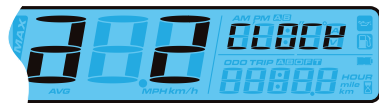

Press the **Select button** to enter the clock (Hour) setting.



The clock (Hour) setting

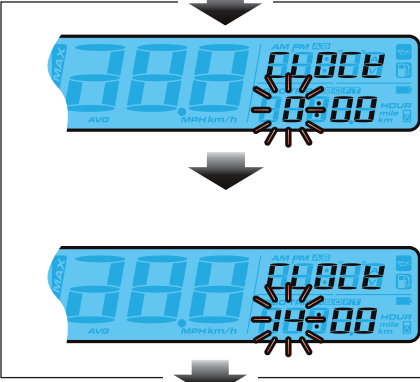

EX: You want to set the hour at 14.

Press the **Select button** to choose the hour you want to set.

NOTE: Setting range: 0~23 H.

NOTE: The sequent of cursor movement:
Hour>Ten-Digit of Minute>Single Digit of Minute

EX. Now the setting is changed from 0:00 to 14:00.

Press the to enter the **Adjust button** minute setting.

The clock (minute) setting

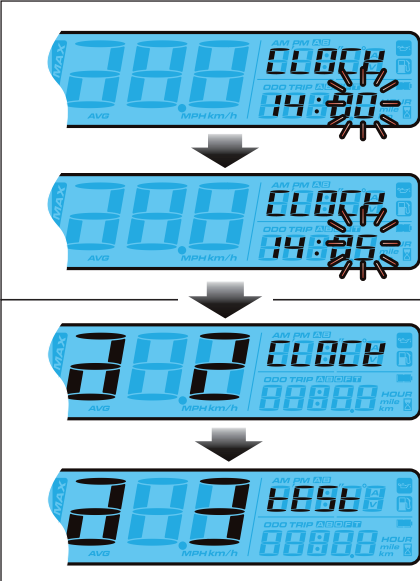

EX. To change the setting to 14:05.

Press the **Select button** to choose the minute you want to set.

NOTE: Setting range: 0~59 minutes..

EX. Now the minute is changed from 14:00 to 14:05.

Press **Adjust button** to get back to Clock setting screen.

Switch from **a 2** to **a 3**

Press **Select button** to switch to Stopwatch distance setup entering screen.

Press **Adjust button** to enter the distance setup for Stopwatch.

Distance setup for Stopwatch

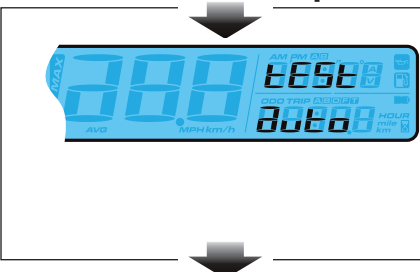

Press the **Select button** to choose auto/manual stopwatch function.

If Auto is chosen, press the **Adjust button** to exit the stopwatch setting function.



NOTE: Default:AUTO

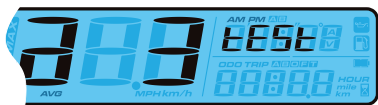

Switch from **a 3** to **a 4**

Press **Select** button to switch to Engine Oil Light Mileage setting screen.



Press **Adjust** button to enter the Engine Oil Light Mileage setting.

Maintenance Light Mileage Setting



Press the **Select** button to choose maintenance mileage ON or OFF.

NOTE: Default: OFF



If ON is chosen, press **Adjust** button to enter the maintenance mileage setting

Press the **Adjust** button to move the cursor to the digit that would like to set.



If OFF is chosen then press the **Adjust** button to exit the maintenance mileage setting.

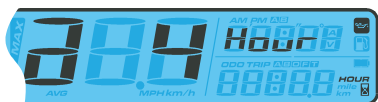

Press Select button to switch the ODO setting screen from **a 4** to **a 5**



Press the **Adjust** button to enter the Backlight Brightness setting.

Backlight brightness



Press the **Select button** to adjust the brightness of the backlight

NOTE: Adjustable Range: 1 ~ 5

NOTE: Default: 5

Press the **Adjust button** to exist from the Backlight Brightness setting.

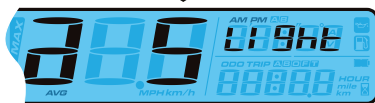

From **2 5** switch to **2 6** screen.

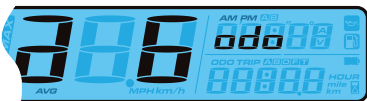

Press **Adjust button** to enter the mileage setting.

ODO setting

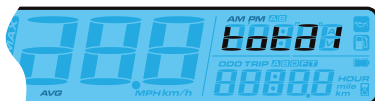

Press the **Adjust button** to enter the actual ODO viewing display (ODO).

Press the **Select button** to enter the User ODO setting (user).

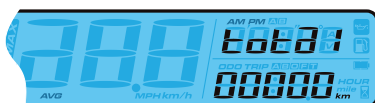

Press **Adjust button** to enter the User ODO setting.

Press the **Adjust button** to back to ODO adjust function

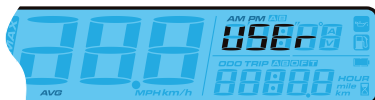

Press **Select Button** to switch to ODO viewing adjusting function.

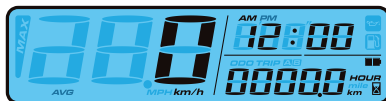

In Setting Screen, press and hold the both **Adjust and Select button** for 3 sec. to exist the setting.

2 CHECKS BEFORE AND AFTER USE

For safe driving and long vehicle life you should:

- 1 Check the integrity of the oil pipe connecting the intake manifold to the electronic dosing.
- 2 Check all fluid levels.
- 3 Check the correct operation of the brakes and brake pad wear (page 54).
- 4 Check pressure, general condition and thickness of tread (page 65).
- 5 Check that the spokes are properly tightened.
- 6 Check the tensioning of the chain (page 65).
- 7 Check the adjustment and the operation of all the cable controls.
- 8 Inspect all the nuts and bolts.
- 9 With the engine running, check the operation of the headlight, the rear and brake lights, the indicators, the warning lights and the horn.
- 10 Wash the motorcycle thoroughly after off-road use (page 71).

RUNNING IN

The running-in period lasts approximately 15 hours, during which it is advisable to:

- 1 Make the first refuelling with a mixture of 1%.
- 2 Use the oil indicated on page 16 in the "Recommended lubricants and liquids" table.
- 3 During the first 3 hours of operation the engine should only be used to approximately 70 percent of its power. In addition, the engine speed should not exceed 7,000 rpm.
- 4 For the next 2 hours of operation the engine should only be used to about 90 percent of its power.
- 5 Use the vehicle after properly warming up the engine.
- 6 Avoid travelling at constant speed (changing the speed causes the different components to bed in evenly and more quickly).

This procedure should be followed each time piston, piston rings, cylinder, crankshaft or crankshaft bearings are replaced.

WARNING

Replace the transmission oil after the first 3 hours or after 15 l. of mixture.

REFUELLING

See page 16 for the fuel specifications.

Fuel tank capacity is shown on page 10.

To refuel open the tank cap (page 18).

After refuelling, screw the cap back and tighten securely.



WARNING

The refuelling should be performed with the engine off.



WARNING:

Fire hazard. Fuel is highly flammable.



Always stop the engine when refuelling and keep open flames and lighted cigarettes away.



Do not top up fuel while using a mobile phone.

Refuel in an open well ventilated area.

Pay special attention so that the fuel does not come into contact with hot parts of the vehicle. Immediately clean up any spilled fuel.



WARNING: Risk of poisoning.

Fuel is poisonous liquid and a health hazard.



Fuel must not come into contact with the skin, eyes, and clothing. Do not breathe in the fuel vapours. If contact occurs with the eyes, rinse immediately with plenty of water and seek medical advice. If contact occurs with skin, immediately clean contaminated areas with soap and water. If fuel is swallowed, contact a doctor immediately. Change clothing that is contaminated with fuel.

WARNING: Environmental pollution hazard.

The fuel must not contaminate the ground water, the ground, or the sewage system.

2 OIL MIXER REFUELLING

To refuel open the tank cap (page 19).

Fuel tank capacity is shown on page 10.

After refuelling, screw the cap back and tighten securely.

Use the oil indicated on page 16 in the “Recommended lubricants and liquids” table.

STARTING THE ENGINE

Move the fuel tank valve in **ON** or **RES** position (page 18).

Check that the gears are in neutral (page 21).

Pull the clutch lever (page 19).

Close the side stand (page 21).

WHIT ELECTRIC STARTER (page 20):

Push the button until the engine starts.

Do not press the button while the engine is running.

COLD STARTING:

Operate the starter (page 19), start the vehicle, wait a few seconds, then move the starter back to its starting position.

ENGINE SHUT-DOWN

To shut-down the engine press the button  on the left switch unit (page 20).

NOTE:

With the engine off, make sure the fuel cock is set to OFF (page 18).

CHAPTER 3 ADJUSTMENTS

CONTENTS

Key to symbols.....	36
Brakes	36
Front brake	36
Rear brake	36
Clutch.....	37
Adjustment of gas clearance.....	37
Adjusting the idle speed.....	37
Carburetor settings according to the working conditions.....	38
Exhaust valve control adjustment	41
Handlebar adjustment	41
U-bolt position adjustment	41
Adjustment of the handlebar position	42
Adjusting fork	42
Adjusting the rebound damper	42
Adjusting the spring preload	42
Shock absorber.....	43
Adjusting the rebound damper	43
Adjusting the hydraulic compression damper	43
Adjusting the spring preload	44
Static sag load test	44

KEY TO SYMBOLS



Tightening torque



Threadlocker Medium

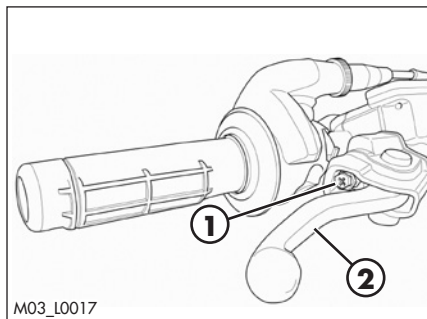

BRAKES

FRONT BRAKE

The front brake is disk type with hydraulic control.

The home position of brake lever **2** can be adjusted by means of screw **1**.

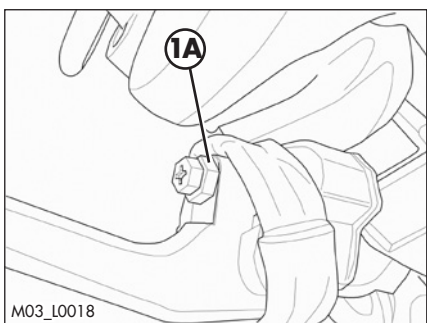

Warning! Once the adjustment has been made, tighten the locknut **1A**.

Warning! Do not remove the locknut for any reason **1A**.

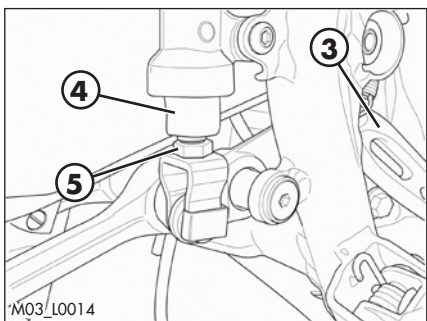

REAR BRAKE

The home position of brake pedal **3** can be altered by turning adjusting screw **5** after loosening the counternut located under dust cap **4**. Loosen the counternut and turn the adjusting screw until the desired height is obtained. Retighten the counternut after completing the operation.

CLUTCH

The adjustment screw **1** allows adjustment of the distance of lever **2** from the knob. The empty run is recovered automatically.

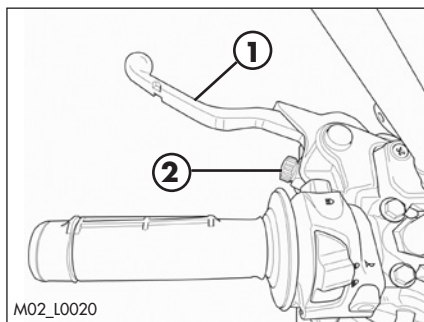

ADJUSTMENT OF GAS CLEARANCE

The throttle control cable should always have a 3-5 mm play. In addition, the idle speed should not change when the handlebars are fully rotated to the left or right. Push back protective cap **1**. Loosen counter nut **2** and turn adjusting screw **3**. Tighten the counter nut and check that the throttle twist grip turns smoothly.

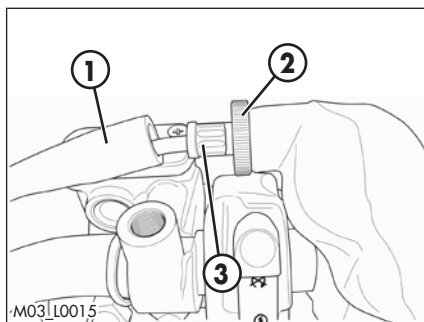

ADJUSTING THE IDLE SPEED

Idling adjustment greatly affects the appropriate start-up and the accelerator response.

Idling is adjusted through adjustment screw **1** and air adjustment screw **2**. Adjustment screw **1** adjusts the basis position of the gas valve. Turn the screw clockwise to increase the rotation conditions and counterclockwise to diminish it. The air adjustment screw **2** adjusts the quantity of which is mixed to the fuel for idling. If the screw is turned counterclockwise, the quantity of air increases (thin mix), if turned clockwise, the quantity of air diminishes (fat mix).

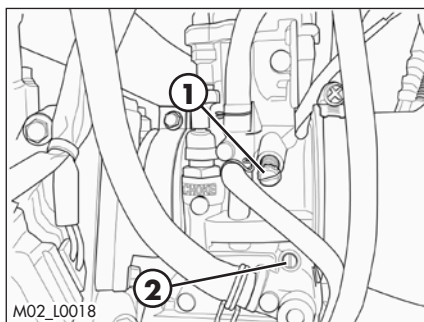

To properly adjust the idle speed, follow these steps:

- Tighten the air adjustment screw no. 2 fully and then loosen it up to the value described in the carburetor setting table (page 12)
- Warm the engine for approx. 5 minutes, until the operational temperature is attained.
- Slowly turn the air adjustment screw **2** clockwise, until idling starts diminishing.
- Mark the position, then slowly turn the air adjustment screw no. **2** counterclockwise, until idling decreases again.
- Adjust the screw between these two positions, at the highest idling point.

If a remarkable increase in the rpm occurred during the adjustment above, idling is to be reduced and taken back to the normal level, and then execute the above procedure.

If no satisfactory results are obtained after the procedure, this may be due to an incorrect slow-running jet.

If the air adjustment screw has been thoroughly tightened, but the rpm have not varied, a lower size slow-running jet is to be used.

Execute the adjustment procedure again after replacing the jet.

NOTE:

The correct idling should be between 1500 and 1600 rpm.

CARBURETOR SETTINGS ACCORDING TO THE WORKING CONDITIONS

See the following tables to adjust the carburetor settings according to ambient temperature and altitude.

Legend:

SJM	Above sea level
AVA	Air screw opening (from all closed)
Gm	Slow jet
SPL	Needle
POS	Needle position (from top)
GM	Main jet
VLV	Valve

Standard settings

XTRAINER 250 2T							
Altitude (SLM)	Carburetor setting	Ambient temperature					
		-20°C ÷ ÷-7°C	-6°C ÷ 5°C	6°C ÷ 15°C	16°C ÷ 24°C	25°C ÷ 36°C	37°C ÷ 49°C
		-2°F ÷ 20°F	19°F ÷ 41°F	42°F ÷ 60°F	61°F ÷ 78°F	79°F ÷ 98°F	99°F ÷ 120°F
3000 m	AVA	1,25	1,5	1,5	2	2	
10000 ft	Gm	35	35	35	35	35	
↑	GM	155	152	150	148	145	
	SPL	NOZK	NOZK	NOZK	NOZK	NOZL	
2301 m	POS	3	3	3	2	1	
7501 ft	VLV	7,5	7,5	7,5	7,5	7,5	
2300 m	AVA	1,25	1,25	1,5	1,5	2	2
7500 ft	Gm	38	35	35	35	35	35
↑	GM	158	155	152	150	148	145
	SPL	NOZK	NOZK	NOZK	NOZK	NOZK	NOZL
1501 m	POS	3	3	3	3	2	1
5001 ft	VLV	7,5	7,5	7,5	7,5	7,5	7,5
1500 m	AVA	1,25	1,25	1,25	1,5	1,5	2
5000 ft	Gm	38	38	35	35	35	35
↑	GM	160	158	155	152	150	148
	SPL	NOZJ	NOZK	NOZK	NOZK	NOZK	NOZK
751 m	POS	4	3	3	3	3	2
2501 ft	VLV	7,5	7,5	7,5	7,5	7,5	7,5
750 m	AVA	1,25	1,25	1,25	1,25	1,5	1,5
2500 ft	Gm	40	38	38	38	38	38
↑	GM	162	160	158	155	152	150
	SPL	NOZJ	NOZJ	NOZK	NOZK	NOZK	NOZK
301 m	POS	5	4	3	3	3	3
1001 ft	VLV	7,5	7,5	7,5	7,5	7,5	7,5
300 m	AVA	1	1,25	1,25	1,25	1,25	1,5
1000 ft	Gm	40	40	38	38	35	35
↑	GM	165	162	160	158	155	152
	SPL	NOZJ	NOZJ	NOZJ	NOZK	NOZK	NOZK
0 m	POS	5	5	4	3	3	3
0 ft	VLV	7,5	7,5	7,5	7,5	7,5	7,5

XTRAINER 300 2T

Altitude (SLM)	Carburetor setting	Ambient temperature					
		-20°C ÷-7°C	-6°C ÷ 5°C	6°C ÷ 15°C	16°C ÷ 24°C	25°C ÷ 36°C	37°C ÷ 49°C
		-2°F ÷ 20°F	19°F ÷ 41°F	42°F ÷ 60°F	61°F ÷ 78°F	79°F ÷ 98°F	99°F ÷ 120°F
3000 m	AVA	1,5	2	2	2,5	2,5	
10000 ft	Gm	35	35	35	35	35	
↑	GM	155	152	150	148	145	
	SPL	NOZJ	NOZJ	NOZK	NOZK	NOZK	
2301 m	POS	2	2	1	1	1	
7501 ft	VLV	7,5	7,5	7,5	7,5	7,5	
2300 m	AVA	1,5	1,5	2	2	2,5	2,5
7500 ft	Gm	38	35	35	35	35	35
↑	GM	158	155	152	150	148	145
	SPL	NOZJ	NOZJ	NOZJ	NOZK	NOZK	NOZK
1501 m	POS	2	2	2	1	1	1
5001 ft	VLV	7,5	7,5	7,5	7,5	7,5	7,5
1500 m	AVA	1,5	1,5	1,5	2	2	2,5
5000 ft	Gm	38	38	35	35	35	35
↑	GM	160	158	155	152	150	148
	SPL	NOZI	NOZJ	NOZJ	NOZJ	NOZK	NOZK
751 m	POS	2	2	2	2	1	1
2501 ft	VLV	7,5	7,5	7,5	7,5	7,5	7,5
750 m	AVA	1,5	1,5	1,5	1,5	2	2
2500 ft	Gm	40	38	38	38	38	38
↑	GM	162	160	158	155	152	150
	SPL	NOZI	NOEI	NOZJ	NOZJ	NOZJ	NOZK
301 m	POS	3	2	2	2	2	1
1001 ft	VLV	7,5	7,5	7,5	7,5	7,5	7,5
300 m	AVA	1	1,5	1,5	1,5	1,5	1,5
1000 ft	Gm	40	40	38	38	35	35
↑	GM	165	162	160	158	155	152
	SPL	NOZH	NOZI	NOZI	NOZJ	NOZJ	NOZJ
0 m	POS	4	3	2	2	2	2
0 ft	VLV	7,5	7,5	7,5	7,5	7,5	7,5

EXHAUST VALVE CONTROL ADJUSTMENT

ATTENTION! The vehicle is provided with an exhaust valve whose fine tuning is performed during the final try-out of the engine. The position of adjustment valve **1** must not be modified for any reason.

For any adjusting, please contact Betamoto's Authorized Service Network.

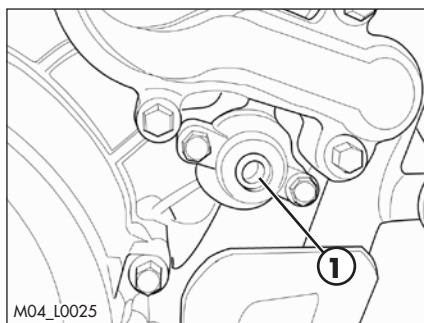

HANDLEBAR ADJUSTMENT U-BOLT POSITION ADJUSTMENT

The lower bracket **1** can be mounted in correspondence of the holes nr. **2**, **3** or **4** respectively.

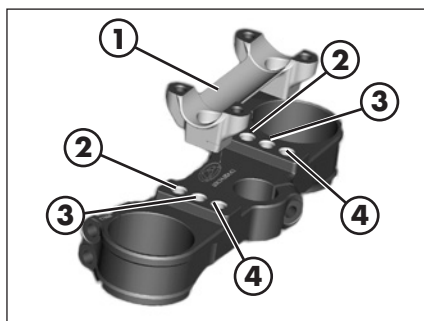

To adjust the position of the u-bolt remove the screws shown in the figure.

Remove the handlebar.

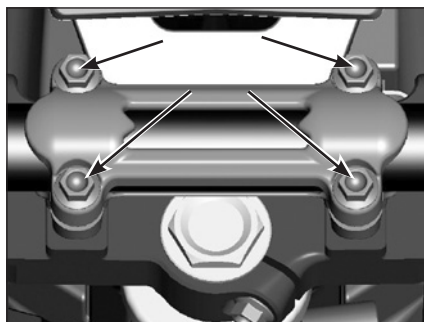

Remove the screws **5**.

Position the U-bolt according to requirements.

At the end refit the screws **5** after the application of thread lock fluid and tighten to the torque indicated.

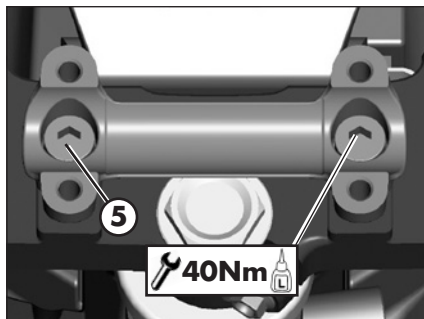

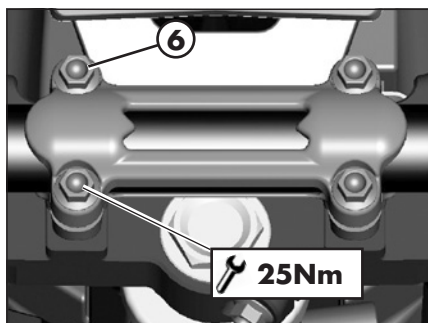

Apply the handlebar.

Apply the top u-bolt.

Refit the screws **6**. Tighten to the torque indicated.

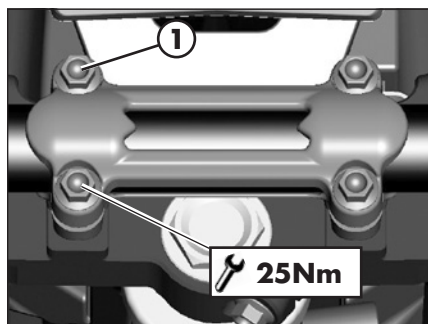

ADJUSTMENT OF THE HANDLEBAR POSITION

The handlebar can be adjusted by rotating it back and forth.

To adjust the handlebar loosen screws **1**.

Position the handlebar according to requirements.

Tighten to the torque indicated.

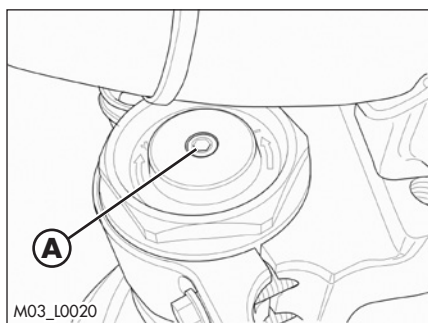

ADJUSTING FORK

ADJUSTING THE REBOUND DAMPER

The hydraulic rebound damper determines the behaviour of the telescopic fork during extension and can be adjusted by means of screw **A**. Turning the screw clockwise increases the action of the rebound damper; turning it anticlockwise decreases the action of the rebound damper.

For standard calibration, refer to page 11.

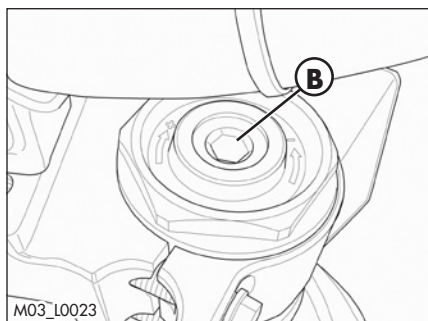

ADJUSTING THE SPRING PRELOAD

Spring preload is adjusted by means of screw **B**. Turning clockwise will increase the preload, while rotating counter-clockwise decreases the preload.

For standard setting, refer to page 11.

SHOCK ABSORBER

ADJUSTING THE REBOUND DAMPER

Turn screw **A** to adjust the hydraulic rebound damper.

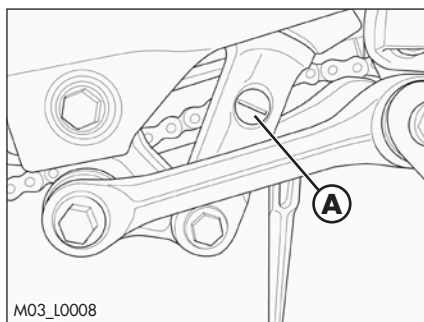

For adjustment refer to the table on the side.
For standard setting, refer to page 11.

Increase braking effect	Decrease braking effect

ADJUSTING THE HYDRAULIC COMPRESSION DAMPER

Turn knob **A** to adjust the hydraulic compression damper.

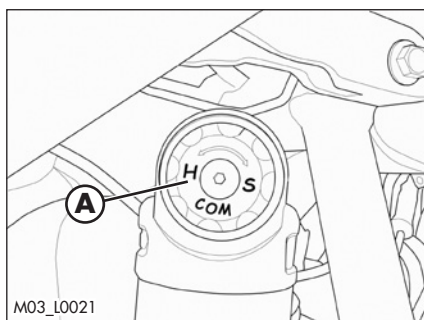

For adjustment refer to the table on the side.
For standard setting, refer to page 11.

Increase braking effect	Decrease braking effect

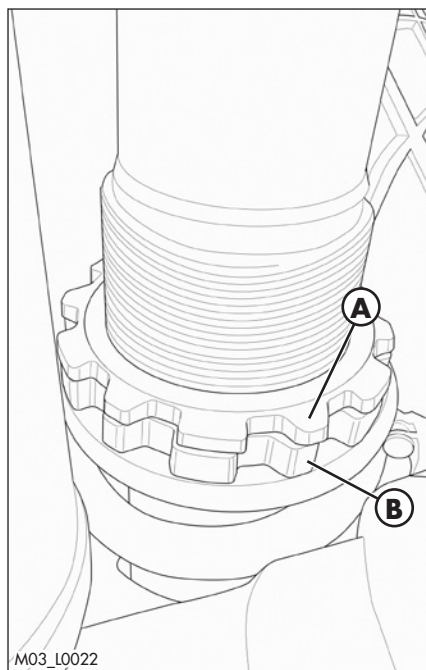

ADJUSTING THE SPRING PRELOAD

To adjust the spring preload, use the procedure described below:

Loosen the locking dowel **A**.

Turn the ring nut **B** until you reach the desired preload.

Lock the locking dowel **A**.

For standard setting, refer to page 11.

Note: for movement of the rings use a specific sector key with square pin.

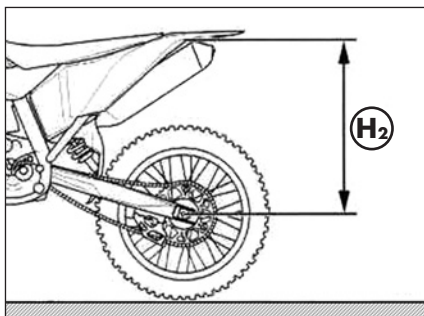
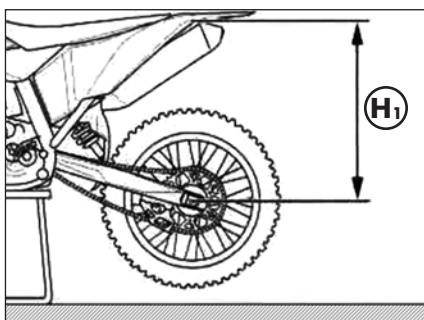

STATIC SAG LOAD TEST

To verify the static sag of the shock absorber proceed as follows:

- Place the motorcycle on the work stand.
- Measure the vertical distance between the rear wheel axle and a reference point on the rear fairings.
- Write down the dimension H_1 .
- Remove the work stand.
- Keep the motorcycle in vertical position and measure again the distance between the wheel axle and the reference point previously established.
- Write down the dimension H_2 .

Verify that the value of the static compression $X = H_1 - H_2$ matches the one shown on page 11. Otherwise, perform the adjustment of the spring preload as described above.

CHAPTER 4 CHECKS AND MAINTENANCE

CONTENTS

Key to symbols.....	46
Engine oil.....	46
Check the level	46
Replacement.....	46
Liquid coolant.....	47
Check the level	47
Replacement.....	48
Air filter	50
Removing and installing air filter	50
Air filter cleaning - XTRAINER 250/300 2T	51
Spark plug	51
Carburettor	52
Draining the carburettor float chamber.....	52
Checking the float level.....	53
Front brake.....	54
Check the level of the front brake fluid	54
Restoring the level of the front brake fluid	54
Bleeding the front brake	55
Front brake lining control	56
Brake disc thickness control	56
Rear brake	57
Check the level of the rear brake fluid	57
Restoring the level of the rear brake fluid.....	57
Bleeding the rear brake	58
Rear brake lining control.....	59
Brake disc thickness control	59
Clutch control	60
Check the level	60
Bleeding	61
Check and adjusting of steering play.....	62
Front wheel	63
Tightening	63
Fork.....	64
Rear suspension leverage.....	64
Tyres.....	65
Chain	65
Check and adjust tightening chain.....	65
Check for chain wear	66
Headlight.....	67
Replacing the headlight bulbs	67
Tail light.....	68
Battery.....	68
Battery removal and assembly	68
Inactivity	69
Charging the battery	69
Fuses	70
Cleaning the vehicle.....	71
General precautions	71
Electrical connector maintenance	72
Control unit connector.....	72
Prolonged inactivity.....	73
Scheduled maintenance vehicle	74
Tightening torque overview	76

KEY TO SYMBOLS



Tightening torque



Threadlocker Medium

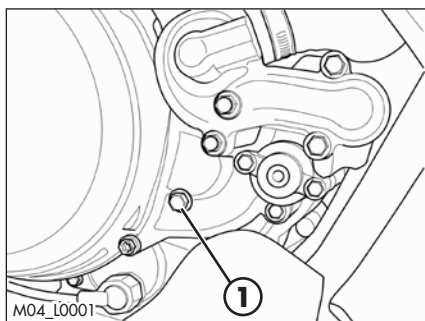

ENGINE OIL

CHECK THE LEVEL

Hold the vehicle upright.
Position the drive on a flat base ensuring stability.

Remove the inspection cap **1**.

The oil level must arrive to the lower edge of check hole.

Otherwise restore the oil level through plug **2**.

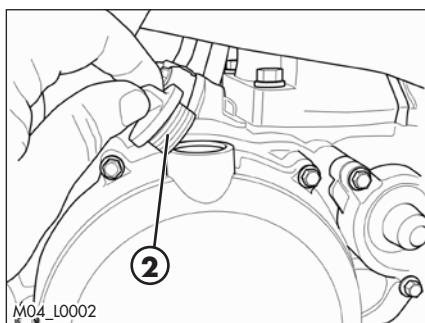

Use the oil indicated on page 16 in the "Recommended lubricants and liquids" table.

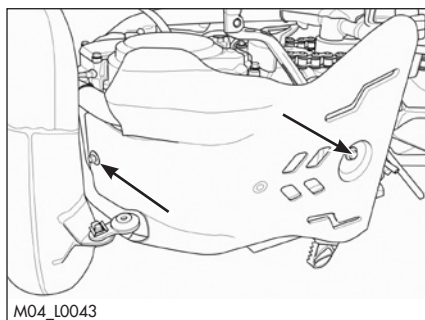

REPLACEMENT

Always perform the replacement when engine is hot:

- Position the drive on a flat base ensuring stability.
- Remove the engine casing by loosening the screws shown in the figure.
- Place a container under the engine.



WARNING:

Hot oil can cause severe burns!

- Unscrew filler plug **1** and drain plug **2**.
- Drain all the oil from the crankcase.
- Place the cap **2** and tighten to specified torque.

Pour in the quantity of liquid indicated on page 10.

Use the oil indicated on page 16 in the "Recommended lubricants and liquids" table.

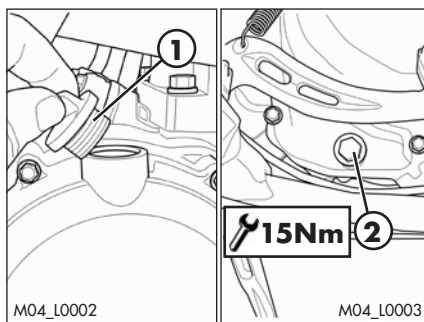

Screw on filler cap **1** again.

WARNING:

Dispose of used oil in compliance with the regulations in force.

LIQUID COOLANT

CHECK THE LEVEL

Keep the vehicle in vertical position relative to the ground.

The level of the coolant must be checked when the engine is cold. Use the following procedure:

- Unscrew cap **1** and ensure that the liquid is visible in the lower portion of the loading tube.
- In the case in which the liquid is not visible remove the vent screw **2** and proceed topping up.
- At the end of operation refit the filler cap and the vent screw.

Use the oil indicated on page 16 in the "Recommended lubricants and liquids" table.



WARNING:

Never unscrew the filler cap of the radiator when the engine is hot. Danger of burning!

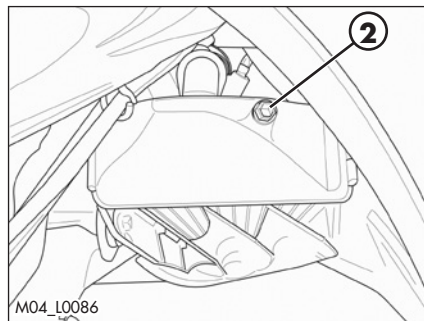
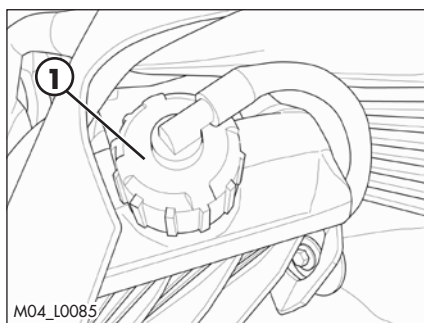
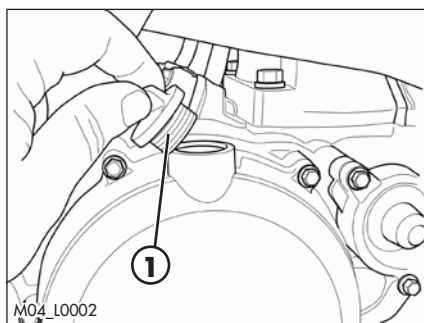

**WARNING:**

Wear appropriate protective clothing and protection gloves.



Keep coolant out of reach of children.



Avoid any direct contact of the coolant with skin, eyes or clothing. If this happens:

- with the eyes, rinse immediately with plenty of water and seek medical advice;
- with skin, Immediately clean contaminated areas with soap and water Change clothing that is contaminated with coolant.

If coolant is swallowed, contact a doctor immediately.

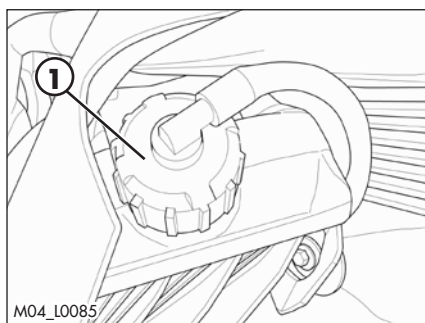
**REPLACEMENT**

Keep the vehicle in vertical position relative to the ground.

Replacement of the coolant must take place when the engine is cold.

- Unscrew cap **1**.

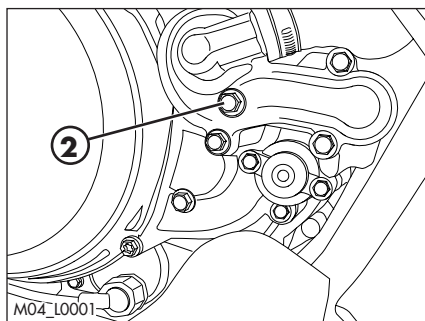

- Place a container under screw **2**.

- Unscrew the screw **2**.

- Drain the liquid.

- Tighten screw **2** applying the specific washer.

- Unscrew drain screw **3**.
- Proceed to filling.
- Reapply the loading cap and the bleeding screw.

The amounts of liquid are shown on page 10.

Use the liquid indicated on page 16 in the "Recommended lubricants and liquids" table.

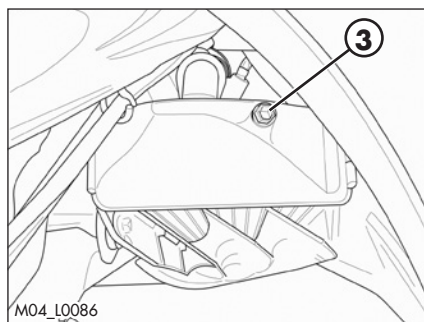

! **WARNING:**
Never unscrew the filler cap of the radiator when the engine is hot.
Danger of burning!

WARNING:
Dispose of used liquid in compliance with the regulations in force.

! **WARNING:**
Wear appropriate protective clothing and protection gloves.

! Keep coolant out of reach of children.

! Avoid any direct contact of the coolant with skin, eyes or clothing. If this happens:

- with the eyes, rinse immediately with plenty of water and seek medical advice;
- with skin, Immediately clean contaminated areas with soap and water Change clothing that is contaminated with coolant.

If coolant is swallowed, contact a doctor immediately.

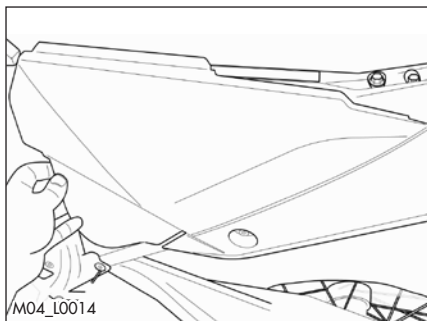

AIR FILTER

Check after every ride.

REMOVING AND INSTALLING AIR FILTER

To access the filter is necessary:

- Remove the saddle (page 78).
- Pull the cover air filter (page 79).

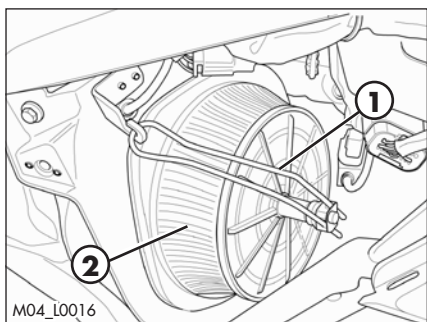

- Release filter fastener **1**.

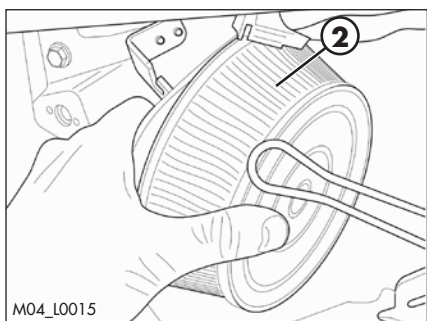

- Pull out air filter **2**.



WARNING:

After every intervention, check that nothing has been left inside the filter box.



NOTE:

If the filter is damaged, replace it immediately.

To replace, contact authorised Beta-motor customer service.



WARNING:

Never use the vehicle if the air filter is not in place. The infiltration of dust and dirt can cause damage and considerable wear.



WARNING:

After every intervention, check that nothing has been left inside the filter box.

Reassemble by performing the operations in reverse order.

AIR FILTER CLEANING - XTRAINER 250/300 2T EUROPA

Blow the filter with compressed air.

AIR FILTER CLEANING - XTRAINER 250/300 2T

- Thoroughly wash the filter with water and soap.
- Dry the filter.
- Wet the filter with filter oil and then remove the excess oil to prevent it from dripping.

SPARK PLUG

Keeping the spark plug in good condition will reduce fuel consumption and increase engine performance.

To perform the check, just extract the spark plug cap and unscrew the spark plug by means of the provided wrench.

Carefully clean the electrodes using a wire brush. Blow the spark plug with compressed air to prevent any residues from getting into the engine.

Examine the distance between the electrodes with a feeler. This distance should be from 0,7 - 0,8 mm. If it is not, it may be corrected by bending the earth electrode.

Check as well that there are no cracks in the insulation or corroded electrodes. If so, replace immediately.

Lubricate the spark plug thread, and then (when the engine is cold) screw in the spark plug by hand to its abutting end. Finally tighten the spark plug with the spanner.

NOTE:

It is recommended to always use the spark plugs listed on page 12.



WARNING:

Do not check while the engine is hot.

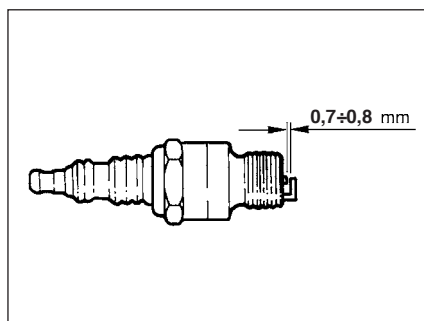

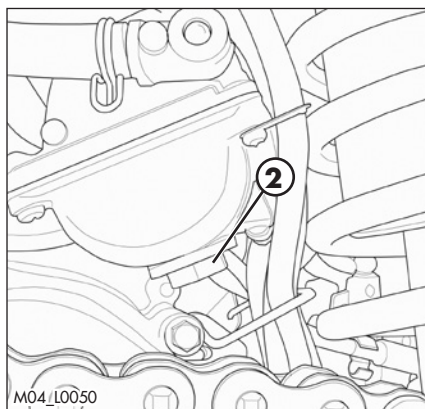
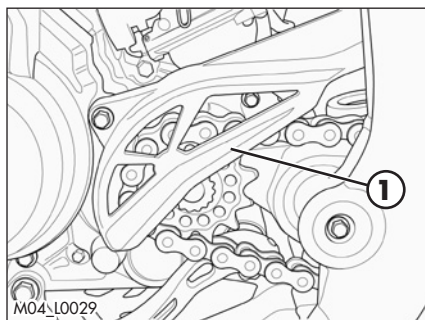

CARBURETTOR

DRAINING THE CARBURETTOR FLOAT CHAMBER

If the carburettor tank needs to be emptied, proceed as described.

Remove the chain protection **1**, close the tank tap and put a cloth under the carburettor, so that you can collect the running out fuel.

Open the drain screw **2** to drain the fuel. Close the drain screw. Apply the chain protection and tighten the screws at 10Nm.



WARNING:

Follow action on a cold engine.



WARNING:

Fire hazard. Fuel is highly flammable.



Always stop the engine when refuelling and keep open flames and lighted cigarettes away.

Refuel in an open well ventilated area.



Immediately clean up any spilled fuel.

**WARNING:**

Risk of poisoning!

Fuel is poisonous liquid and a health hazard.



Wear appropriate protective clothing and protection gloves.

Fuel must not come into contact with the skin, eyes, and clothing. Do not breathe in the fuel vapours. If contact occurs with the eyes, rinse immediately with plenty of water and seek medical advice. If contact occurs with skin, immediately clean contaminated areas with soap and water. If fuel is swallowed, contact a doctor immediately. Change clothing that is contaminated with fuel.

WARNING:

Environmental pollution hazard!

The fuel must not contaminate the ground water, the ground, or the sewage system.

CHECKING THE FLOAT LEVEL

Remove the carburettor from the vehicle after following the procedure for emptying the carburettor bowl (page 71).

Remove the float chamber.

Keep the carburettor on a 60° approx. inclined, so that float leans on the needle valve without pressing it.

In this position the float edge should be parallel with the float chamber sealing surface (see figure).

If the float height does not correspond to the nominal value, check the float needle valve and if necessary replace it.

If the needle valve is in working order, adjust the float height by bending float lever **1**.

Assemble the carburettor tank, assemble the carburettor and check idling.

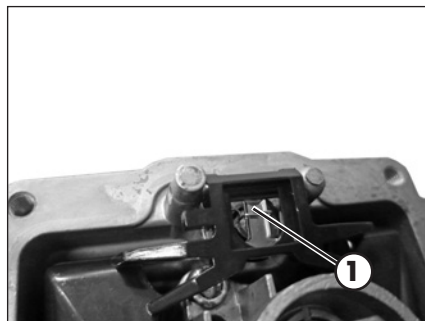
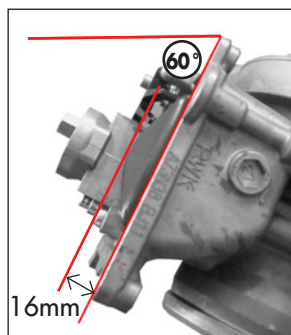

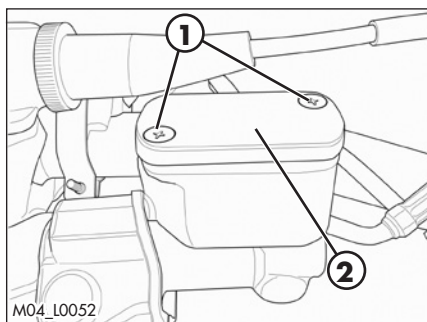
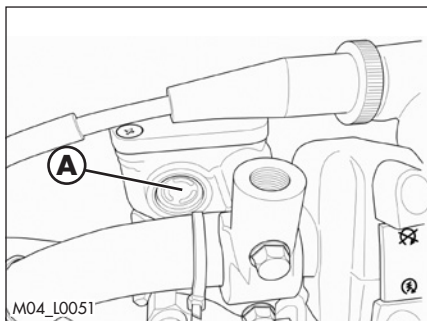

FRONT BRAKE

CHECK THE LEVEL OF THE FRONT BRAKE FLUID

Check the level of the brake fluid through sight **A**. The level of the fluid should never fall below the mark in the sight.

RESTORING THE LEVEL OF THE FRONT BRAKE FLUID

To restore the level of the brake fluid, loosen the two screws **1**, lift cap **2** and add brake fluid until its level is 5 mm below the upper rim of the reservoir.

Use the liquid indicated on page 16 in the "Recommended lubricants and liquids" table.



WARNING:

The clutch fluid is extremely corrosive. Take care not to spill it on the paintwork.



Wear appropriate protective clothing and protection gloves.



Keep coolant out of reach of children.



WARNING: Avoid any direct contact of the liquid with skin, eyes or clothing. If this happens:

- with the eyes, rinse immediately with plenty of water and seek medical advice.
- with skin, immediately clean contaminated areas with soap and water. Change clothing that is contaminated with liquid.

If liquid is swallowed, contact a doctor immediately.

BLEEDING THE FRONT BRAKE

To bleed air from the front brake circuit, proceed as follows:

- Remove the rubber cap **1** from the valve **2**.
- Open the sump cap.
- Place one end of a small transparent tube into the valve **2**, and the other end inside a container.
- Pump with the brake lever 2/3 times and keep the lever pressed.
- Unscrew the valve and let the oil drain.
- If air is still visible in the tube repeat above operation until obtaining a continuous outflow of oil without air bubbles.
- Close the valve and release the lever.

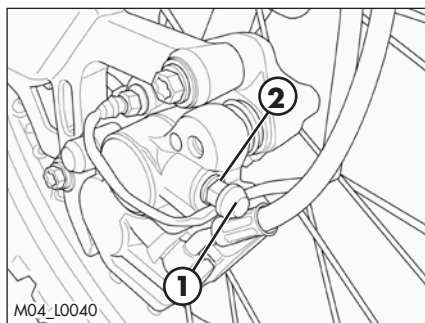

NOTE:

During this procedure, continuously top up the brake pump tank to replace the oil that is out flowing.

- Remove the tube.
- Replace the rubber cap.
- Close the oil reservoir cap.

Use the liquid indicated on page 16 in the "Recommended lubricants and liquids" table.



WARNING:

The brake fluid is extremely corrosive. Take care not to spill it on the paintwork.



Wear appropriate protective clothing and protection gloves.



Keep coolant out of reach of children.



WARNING: Avoid any direct contact of the liquid with skin, eyes or clothing. If this happens:

- with the eyes, rinse immediately with plenty of water and seek medical advice.
- with skin, immediately clean contaminated areas with soap and water. Change clothing that is contaminated with liquid.

If liquid is swallowed, contact a doctor immediately.

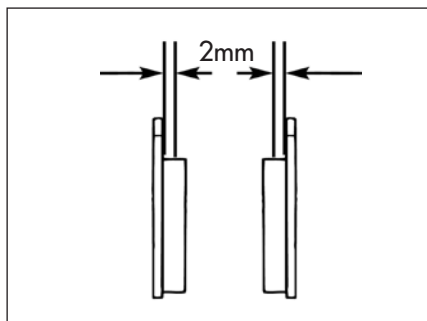

FRONT BRAKE LINING CONTROL

In order to verify the wear condition of front brake is enough to view the caliper from the bottom, where is possible to glimpse the brake lining tails which will have to show a brake of 2 mm in thickness. If the stratum is lesser let's start replacing them.

Note:

Perform the check according to the times shown in the table on page 74.

To replace, contact authorised Betamotor customer service.

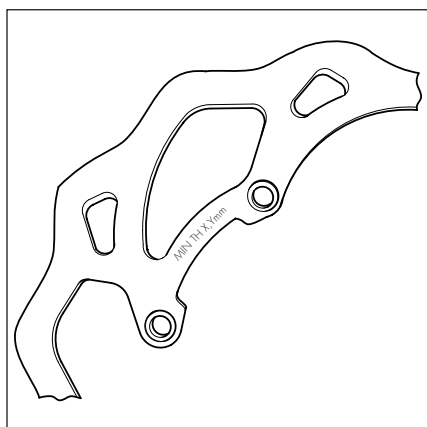

BRAKE DISC THICKNESS CONTROL

Periodically verify disc condition. In case signs of damage, veins, or deformations are present, proceed with replacement. Verify disc thickness. The minimum thickness is engraved on the disc.

Once the limit is in proximity or has been reached, proceed with brake disc replacement.

For replacement, contact an authorised Betamotor after-sales service centre.

REAR BRAKE

CHECK THE LEVEL OF THE REAR BRAKE FLUID

Check the level of the brake fluid through sight **A**. The level of the fluid should never fall below the mark in the sight.

RESTORING THE LEVEL OF THE REAR BRAKE FLUID

To restore the oil level, top up by means of oil filler cap **1**.

Use the liquid indicated on page 16 in the "Recommended lubricants and liquids" table.



WARNING:

The brake fluid is extremely corrosive. Take care not to spill it on the paintwork.



Wear appropriate protective clothing and protection gloves.



Keep coolant out of reach of children.



WARNING: Avoid any direct contact of the liquid with skin, eyes or clothing. If this happens:

- with the eyes, rinse immediately with plenty of water and seek medical advice.
- with skin, immediately clean contaminated areas with soap and water. Change clothing that is contaminated with liquid.

If liquid is swallowed, contact a doctor immediately.

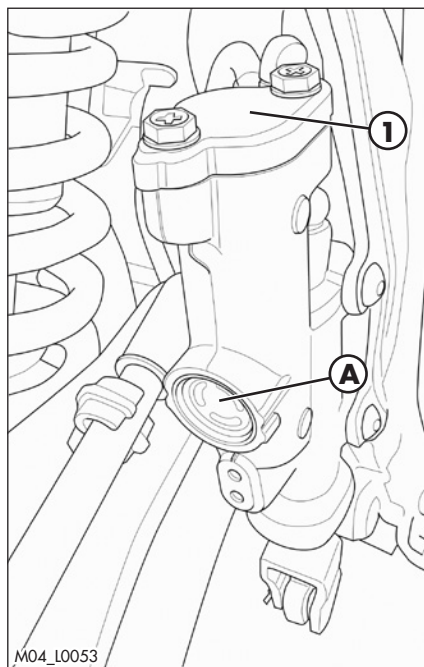

M04_L0053

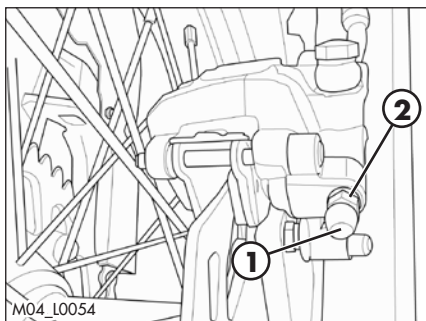

BLEEDING THE REAR BRAKE

To bleed air from the rear brake circuit, proceed as follows:

- Remove the rubber cap **1** from the valve **2**.
- Open the sump cap.
- Place one end of a small transparent tube into the valve **2**, and the other end inside a container.
- Pump with the brake lever 2/3 times and keep the pedal pressed.
- Unscrew the valve and let the oil drain.
- If air is still visible in the tube repeat above operation until obtaining a continuous outflow of oil without air bubbles.
- Close the valve and release the lever.

NOTE:

During this procedure, continuously top up the brake pump tank to replace the oil that is out flowing.

- Remove the tube.
- Replace the rubber cap.
- Close the oil reservoir cap.

Use the liquid indicated on page 16 in the "Recommended lubricants and liquids" table.



WARNING:

The brake fluid is extremely corrosive. Take care not to spill it on the paintwork.



Wear appropriate protective clothing and protection gloves.



Keep coolant out of reach of children.



WARNING: Avoid any direct contact of the liquid with skin, eyes or clothing. If this happens:

- with the eyes, rinse immediately with plenty of water and seek medical advice.
- with skin, immediately clean contaminated areas with soap and water. Change clothing that is contaminated with liquid.

If liquid is swallowed, contact a doctor immediately.

REAR BRAKE LINING CONTROL

In order to verify the wear condition of rear brake is enough to view the caliper from above, where is possible to glimpse the brake lining tails which will have to show a brake of 2 mm in thickness. If the stratum is lesser let's start replacing them.

Note:

Perform the check according to the times shown in the table on page 74.

To replace, contact authorised Betamotor customer service.

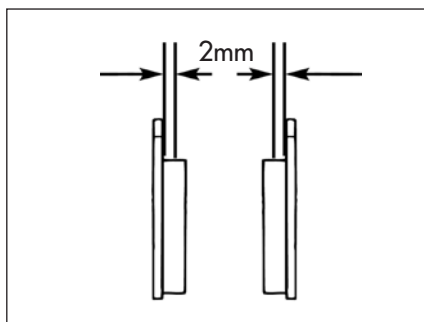

BRAKE DISC THICKNESS CONTROL

Periodically verify disc condition. In case signs of damage, veins, or deformations are present, proceed with replacement. Verify disc thickness. The minimum thickness is engraved on the disc.

Once the limit is in proximity or has been reached, proceed with brake disc replacement.

For replacement, contact an authorised Betamotor after-sales service centre.

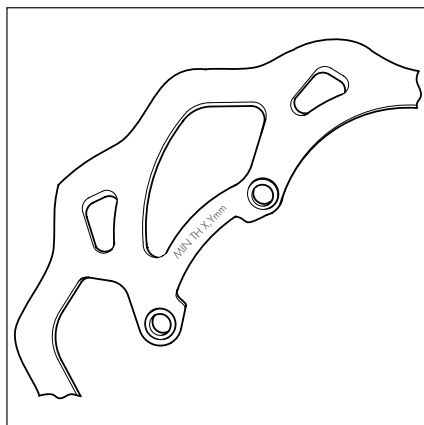

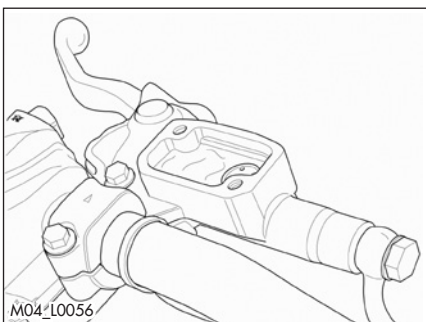
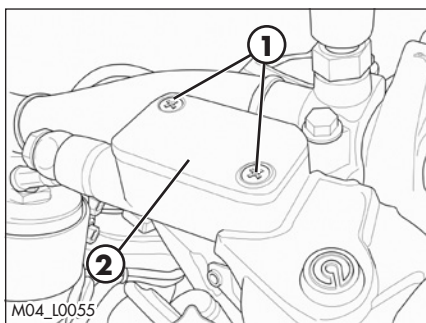

CLUTCH CONTROL

CHECK THE LEVEL

To check the oil level in the clutch pump, first remove cover **2**.

Remove the two screws **1** and take off cover **1** together with the rubber bellows. With the clutch pump in a horizontal position, the level of the oil should be 5 mm below the upper rim.

In the case where the level is lower than specified top up.

Use the liquid indicated on page 16 in the "Recommended lubricants and liquids" table.



WARNING:

The clutch fluid is extremely corrosive. Take care not to spill it on the paintwork.



Wear appropriate protective clothing and protection gloves.



Keep coolant out of reach of children



WARNING: Avoid any direct contact of the liquid with skin, eyes or clothing. If this happens:

- with the eyes, rinse immediately with plenty of water and seek medical advice.
- with skin, immediately clean contaminated areas with soap and water. Change clothing that is contaminated with liquid.

If liquid is swallowed, contact a doctor immediately.

BLEEDING

To bleed air from the clutch pump, proceed as follows:

- Remove the rubber cap **1** from the valve **2**.
- Open the sump cap.
- Place one end of a small transparent tube into the valve **2**, and the other end inside a container.
- Pump with the clutch lever 2/3 times and keep the lever pressed.
- Unscrew the valve and let the oil drain.
- If air is still visible in the tube repeat above operation until obtaining a continuous outflow of oil without any air bubbles.
- Close the valve and release the lever.

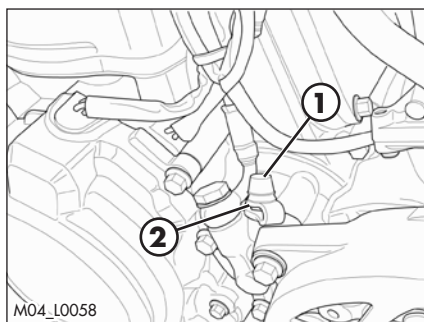

NOTE:

During this procedure, continuously top up the pump tank to replace the liquid that is out flowing.

- Remove the tube.
- Replace the rubber cap.

Use the liquid indicated on page 16 in the "Recommended lubricants and liquids" table.



WARNING:

The clutch fluid is extremely corrosive. Take care not to spill it on the paintwork.



Wear appropriate protective clothing and protection gloves.



Keep coolant out of reach of children.



WARNING: Avoid any direct contact of the liquid with skin, eyes or clothing. If this happens:

- with the eyes, rinse immediately with plenty of water and seek medical advice.
- with skin, immediately clean contaminated areas with soap and water. Change clothing that is contaminated with liquid.

If liquid is swallowed, contact a doctor immediately.

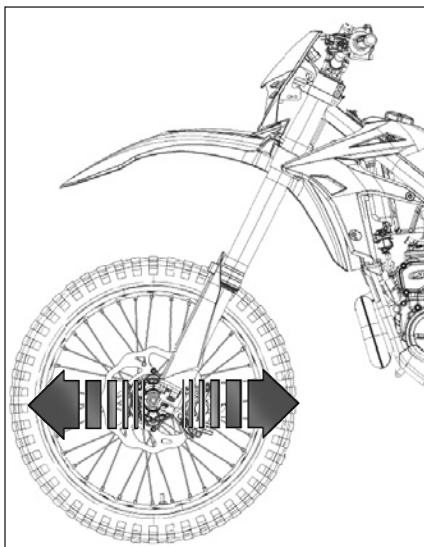

CHECK AND ADJUSTING OF STEERING PLAY

Periodically check the play in the steering sleeve by moving the fork back and forth as shown in the figure. Whenever you feel play, adjust as described below:

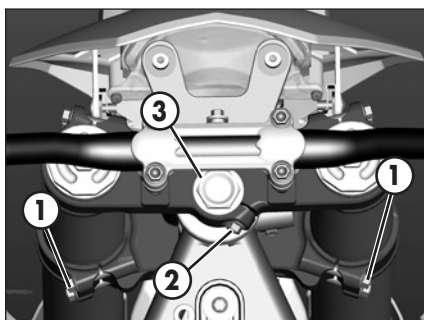

- Loosen the screws **1**
- Loosen the screw **2**
- Reduce the play by turning nut **3**

Tighten the screws to the prescribed torque values.

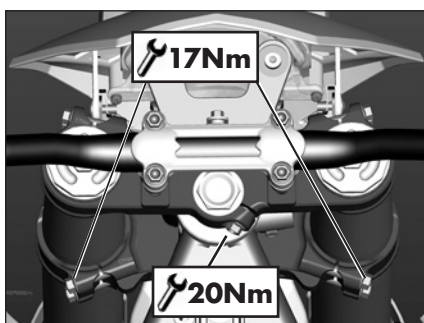

FRONT WHEEL

TIGHTENING

Following removal of the wheel:

- Compress and release the fork 3-4 times.

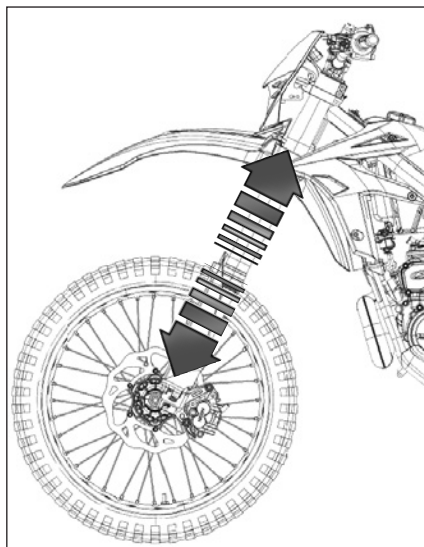

- Tighten the wheel bolt and the screws of the footleg.

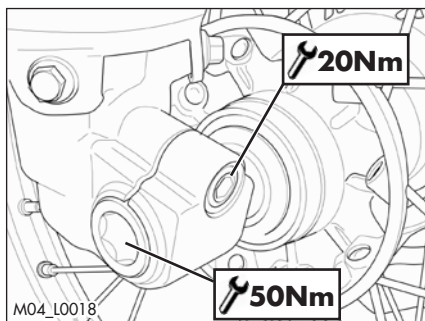

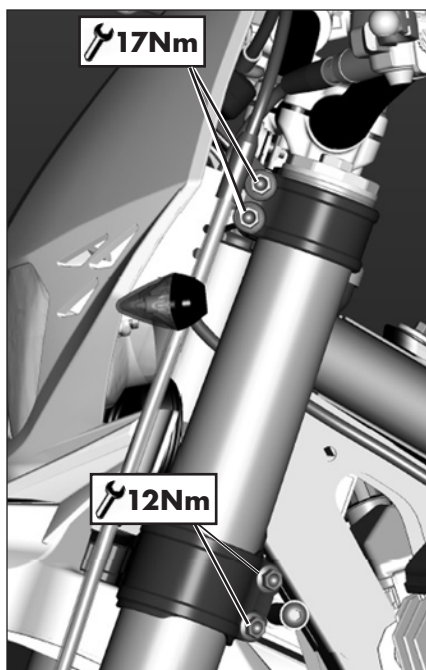

FORK

To maintenance refer at an authorized service center Betamotor.

To check the tightening torques see as shown in the figure.

WARNING:

Tightening of the screws should be carried out by adjusting the torque wrench to the stability torque with repeated tightening until stability torque has been achieved.

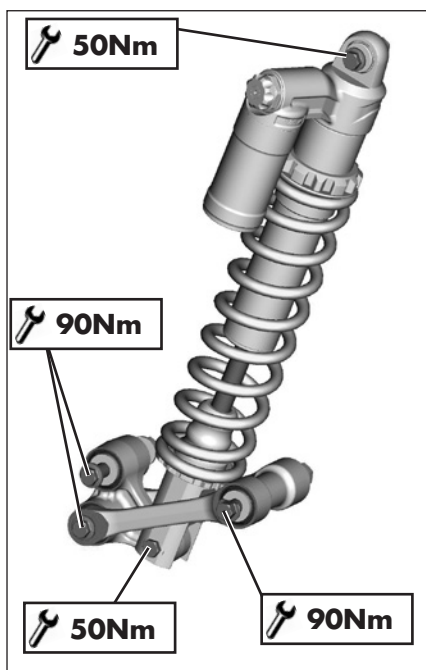

REAR SUSPENSION LEVERAGE

In order to guarantee optimal operation and duration over time of the progressive leverage of the rear suspension, it is recommended to periodically check correct tightness of nuts and bolts.

Verify that suspension nuts and bolts are at the indicated torque.

TYRES

Only fit tyres approved by BETAMOTOR.

Unsuitable tyres can adversely affect the road holding of the vehicle.

- To protect your safety, immediately replace any damaged tyres.
- Slick tyres adversely affect the road holding of the vehicle, especially on wet roads and in off-road riding.
- Insufficient pressure results in abnormal wear and overheating of the tyres.
- The front and rear tyres must have the same tread design.
- Always measure the inflating pressures when the tyres are cold.
- Keep the tyre pressures within the prescribed range.

CHAIN

Checking the drive chain periodically to ensure longer chain life. Always keep it lubricated and clean of deposited dirt.

Take special care in preventing the lubricant from coming into contact with the rear tyre or brake disc, otherwise the tyre grip and the action of the brake would be greatly reduced, making it very difficult to control the vehicle.

CHECK AND ADJUST TIGHTENING CHAIN

Hold the vehicle upright on the ground on a flat base ensuring stability.

The chain clearance must comply with the measure indicated. Tension the chain if the clearance exceeds the indicated value.

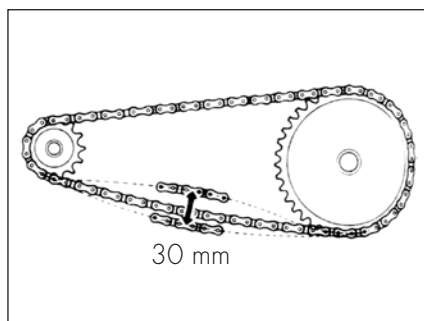

- Loosen the pin **1**.

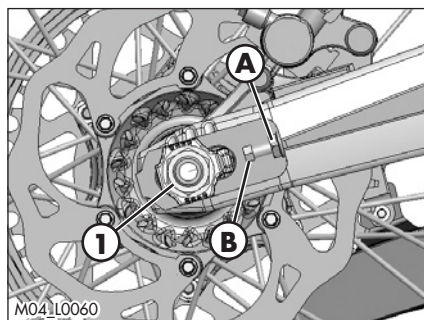

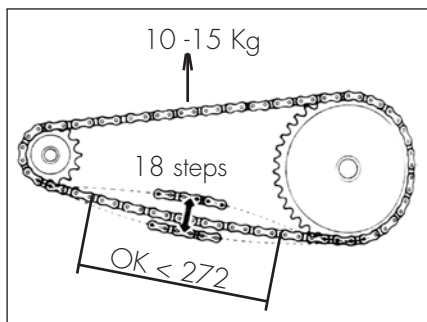
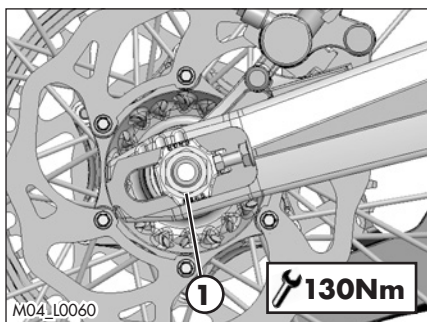
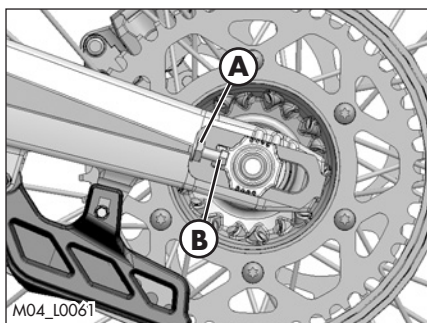

- Loosen counter-nuts **A** on either side of the fork.
- Turn adjusting screws **B** on either side until the desired chain tension is obtained.
- Tighten counter-nuts **A** on either side of the fork.
- Tighten the pin **1** to the torque indicated.

CHECK FOR CHAIN WEAR

Shift into neutral, pull up the upper stretch of the chain with a force of 10 - 15 kg (see figure). Measure the length of 18 links on the lower stretch of the chain. If the length is ≥ 272 mm, replace the chain. Chains do not always wear evenly. For this reason it is important that the measurement is taken at different points along the chain.

When fitting a new chain, be sure to replace the chainring and sprocket as well. New chains wear more quickly if fitted on old and worn sprockets. After replacing the chain, adjust its tension as described on page 65.

HEADLIGHT

Keep the headlight glass clean at all times (see page 71).

Periodically check the correct angle of the light beam.

REPLACING THE HEADLIGHT BULBS

To remove the headlamp mask (page 80).

For the replacement of the day light/position light **1** remove the lamp from the lamp holder and replace it with a new one (page 16 for the lamp type).

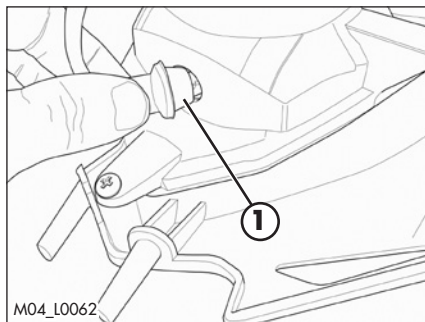

For the replacement of high/low beam:

- remove the rubber cap **2**;
- disconnect the connector **3**;

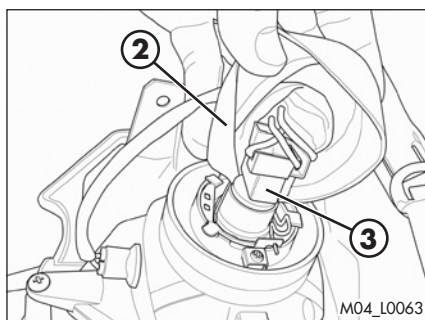

- unhook the spring **4** and remove the light bulb.

Replace with a new lamp (page 16 for lamp data).

Warning: don't touch the bulb to avoid compromising the efficiency of the lamp.

For the reassembly proceed inversely as described above.

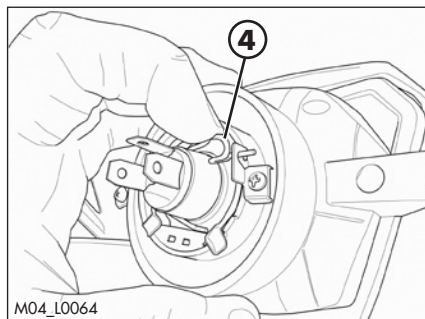

TAIL LIGHT

Keep the tail light glass clean at all times (see page 71).

The LED tail light is sealed. In the case of burnout of one or more LEDs it is necessary to replace the entire group.

To replace, contact authorised Betamotor customer service.

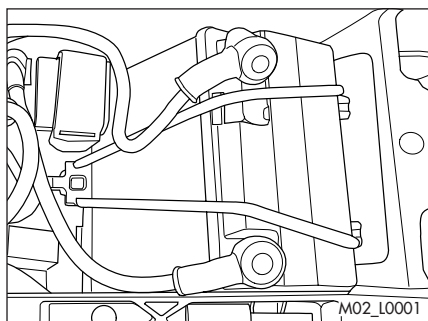

BATTERY

Battery is located under the saddle and requires no maintenance.

Keep the battery terminals clean. If necessary, protect them with a thin film of acid-free grease.

BATTERY REMOVAL AND ASSEMBLY

Remove the saddle (page 78).

Release the rubber band.

FIRST disconnect the negative connector (black) from negative (-) pole and THEN positive connector (black) from negative (+) pole.

Remove the battery.

When fitting the battery, insert it with the terminals as shown in picture.

FIRST connect the positive connector (red) from positive (+) pole and then negative connector (black) from negative (-) pole.

Reattach the rubber band.

WARNING:

Exercise extreme caution if, for any reason, the electrolyte (sulphuric acid) should come out of the battery. The electrolyte can cause serious burns. In case of contact with the skin, rinse abundantly with water.

Should the electrolyte come into contact with the eyes, rinse with water for at least 15 minutes and immediately seek medical attention.

Even though the battery is sealed, there is a possibility that explosive gases may leak out.

Keep sparks and open flames away from the battery.

Keep spent batteries out of the reach of children and dispose of them as prescribed by law.

Do not remove the protections.

When installing the battery, be sure to observe the polarity of the terminals.

INACTIVITY

If the vehicle is not going to be used for a long time, remove the battery and charge it every 15 days using a suitable charger.

Store the battery in a dry place at a temperature of 5 to 35°C and out of the reach of children.

CHARGING THE BATTERY

Using an open-circuit multimeter (10-12 hours after the activation), check that the voltage is greater than 12.6 V. If it is lower, it is advisable to recharge the battery.

Based on the type of charger available, charge the battery using either of the following procedures:

- Constant voltage (14.4÷15 V) - Charge the battery for about 12 hours. Check the voltage 10÷12 hours after the end of recharge as described above.
- Constant current: Charge battery at 0.5/0.8 A until the voltage between the terminals stabilizes at ~14.5 V.

WARNING:

The battery is sealed. When recharging it, do not remove the seal nor add any liquid.

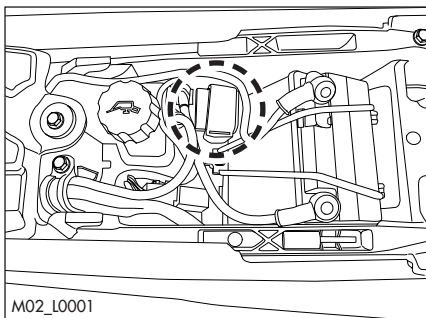

FUSES

To access the fuse, remove the saddle (page 78).

In the case of blown fuse, the vehicle will not start/stop:



Three spare fuses comes with the kit accompanying the vehicle.

A blown fuse should only be replaced with another of the same type.

Should the new fuse also burn out when fitted, immediately contact a specialized BETAMOTOR dealer.

CLEANING THE VEHICLE

GENERAL PRECAUTIONS

-  **WARNING:** Do not clean your vehicle with a high-pressure device with a strong jet of water. Excessive pressure can reach electrical components, connectors, flexible cables, bearings, etc and can damage or destroy them.
-  **WARNING:** Wash motorbikes frequently with cold water that are used near the sea (salty air) and on roads subject to salt spreading in winter. Cover with a film of oil or silicone spray unpainted parts and the most exposed parts such as wheels, forks and swingarm. Do not treat rubber parts and brakes.

When cleaning, avoid direct exposure to sunlight.

Close off the exhaust system to prevent water from entering.

-  Avoid directing the jet of water onto the air filter box cover and the throttle body.

WASHING MODE



Use water jet to soften the dirt and mud accumulated on the paintwork, then remove them with a soft bodywork sponge soaked in water and shampoo. Subsequently rinse well with water, and dry with air and cloth or suede leather.

Detergents pollute water. Always wash the vehicle in areas equipped for collection and purification of the washing liquids.

AFTER WASHING

Proceed to the emptying of the filter box using the appropriate ventilation and drying.

After cleaning, ride a short distance until the engine reaches operating temperature.

-   **WARNING:** braking effect is reduced with wet brakes. Operate the brakes cautiously to allow them to dry.

Push back the handlebar control covers, so that water can evaporate.

When the bike is completely dry and cooled down, lubricate all moving parts.

Treat all plastic and painted components with non-aggressive detergents or products that are specific for the care of the motorcycle.

ELECTRICAL CONNECTOR MAINTENANCE

Disconnect the connectors listed below, blow compressed air on the connector both on the system and on the component side, and treat electrical contacts and switches with spray for electrical contacts.

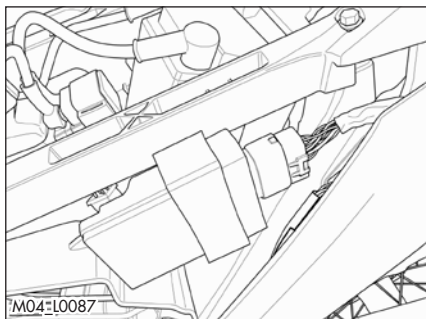

CONTROL UNIT CONNECTOR

The connector location is shown in figure. To access the control unit connector it is necessary to remove the air filter cover panel (page 79).

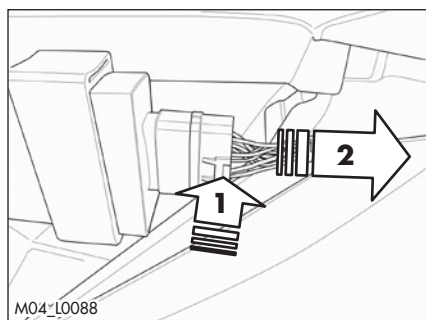

To remove the connector:

- 1) press the lock device;
- 2) pull the connector towards the rear;
- 3) remove the connector.

For re-assembly, proceed opposite the above-mentioned order.

PROLONGED INACTIVITY

A few simple operations should be performed to keep the vehicle in good condition whenever it is to remain inactive for a long period (e.g. during the winter):

- Thoroughly clean the vehicle.
- Reduce the tyre pressures by approximately 30 percent, and if possible raise the tyres off the ground.
- Cover the unpainted parts, excepting the brakes and the rubber parts, with a film of oil or spray silicone.
- Remove the battery and keep it in a dry place. Charge the battery every 15 days.
- Protect the vehicle with a dust cover.

AFTER PROLONGED INACTIVITY

- Reinstall the battery.
- Restore the tyre inflating pressures.
- Check the tightening of all the screws having an important mechanical function.

4 SCHEDULED MAINTENANCE VEHICLE

CHECKS AND MAINTENANCE

		End of running-in - 3 hours	Coupon 1 - 30 hours	Coupon 2 - 60 hours	Coupon 3 - 90 hours	Coupon 4 - 120 hours	Coupon 5 - 150 hours	Coupon 6 - 180 hours
Engine	Gear and clutch oil	S	S	S	S	S	S	S
	Spark plug	C		S		S		S
	Head screws	T						
	Engine clamping screws *	C	C	C	C	C	C	C
	Kick start and gearchange lever screws	C	C	C	C	C	C	C
	Spark plug cap	P	P	P	P	P	P	P
	Coated clutch disks		C	C	S	C	C	S
	Clutch springs length		C	C	S	C	C	S
	Clutch/bell hub		C	C	C	C	C	C
	Gearbox bearing (drive shaft side)				S			S
	Cylinder			C		C		C
	Piston and segments			S		S		S
	Connecting rod				S			S
	Drive shaft bearings				S			S
	Surface appearance of the gearbox				C			C
	Water pump oil seal				S			S
	Exhaust valve			C/P			C/P	
Reed valve			C		C		C	
Carburetor	Tightness	C	C	C	C	C	C	C
	Idling setting	C	C	C	C	C	C	C
	Fuel pipe	C	C	C	C	C	C	C
	Breather pipe	C	C	C	C	C	C	C
Assembling groups	Coolant system tightness and coolant level	C	C	C	C	C	C	C
	Exhaust manifold tightness	C	C	C	C	C	C	C
	Drives sliding and regulation	C	C	C	C	C	C	C
	Liquid level clutch pump	C	C	C	C	C	C	C
	Airbox and air filter	P	P	P	P	P	P	P
	Chain, plate wheel and pinion	C	C	C	C	C	C	C

Key

C Check (Clean, adjust, lubricate, replace as necessary)

S Replace/renew

R Adjust

P Clean

T Tighten

		End of running-in - 3 hours	Coupon 1 - 30 hours	Coupon 2 - 60 hours	Coupon 3 - 90 hours	Coupon 4 - 120 hours	Coupon 5 - 150 hours	Coupon 6 - 180 hours
Brakes	Liquid level, pads thickness	C	C	C	C	C	C	C
	Disc thickness	C	C	C	C	C	C	C
	Pipe tightness	C	C	C	C	C	C	C
	Idle travel levers and drives sliding	C	C	C	C	C	C	C
Cycling	Shock absorber and telescopic fork	C	C	C	C	C	C	C
	Rear suspension linkage	C	C	C	C	C	C	C
	Fork cover	P	P	P	P	P	P	P
	Bearings of steering	C	C	C	C	C	C	C
	Bolts	T	T	T	T	T	T	T
Wheels	Wheel spokes and rim coaxiality	C	C	C	C	C	C	C
	Tyres (wear and pressure)	C	C	C	C	C	C	C
	Bearings clearance	C	C	C	C	C	C	C

Key

C Check (Clean, adjust, lubricate, replace as necessary)

S Replace/renew

R Adjust

P Clean

T Tighten

(*) Attachment	Screw	Threadlocker	Torque [Nm]
Engine to chassis	Special screw M10		45
Brackets to attach the head to the chassis	M8x16	M*	35
Brackets to attach the head to the engine	M8x60		35

* Medium resistance thread locker

WARNING:

For any service requirements, please contact Betamotor's Authorized Service Network.

4 TIGHTENING TORQUE OVERVIEW

Here below is an overview of the tightening torque of all pieces subject to adjustment or maintenance:

Forecarriage		
	Tightening torque [Nm]	Threadlock
Wheel pin	50	
Fork foots - wheel pin	20	
Cavallotto parastelo sinistro	1,5	
Steering head base - fork legs	12*	
Steering head - fork legs	17*	
Stem pin on steering head	20	
Lower handlebar u-bolt - steering head	40	M
Upper handlebar u-bolt - lower handlebar u-bolt	25	

Rear axle		
	Tightening torque [Nm]	Threadlock
Wheel pin	130	
Rear shock absorber - frame	50	
Rear shock absorber - rocker arm	50	
Connecting rod - frame	90	
Connecting rod - rocker arm	90	
Rocker arm - swinging arm	90	

Engine		
	Tightening torque [Nm]	Threadlock
Gearbox oil drain plug	15	

Engine - Frame		
	Tightening torque [Nm]	Note
Pins motor - frame	45	
Brackets to attach the head - frame (front fixing)	35	M
Brackets to attach the head - frame (rear fixing)	35	M
Brackets to attach the head - motor	35	

M Medium strength threadlock



* WARNING:

Tightening of the screws should be carried out by adjusting the torque wrench to the stability torque with repeated tightening until stability torque has been achieved.

CHAPTER 5 REPLACEMENTS

CONTENTS

Removal and refitting of the saddle.....	78
Removing and installing air filter cover panel.....	79
Removing and installing the headlamp mask	80

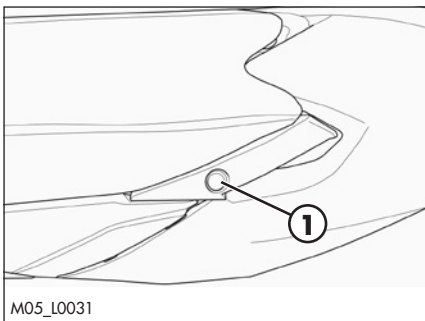

M05_L0031

REMOVAL AND REFITTING OF THE SADDLE

Press button **1**.

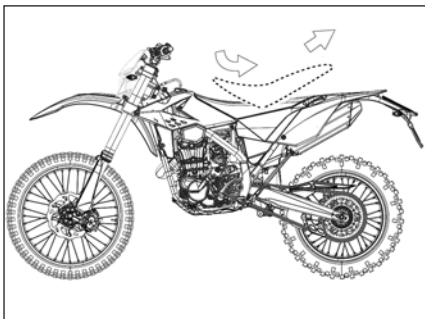

Remove the saddle towards the rear of the motorcycle.

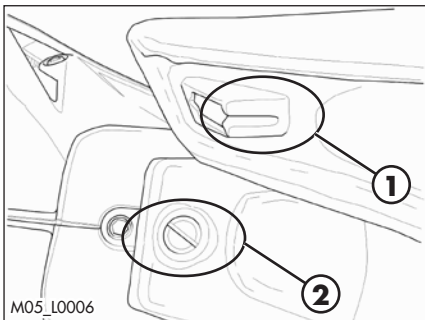

M05_L0006

To re-assemble insert the cavity **1** of the saddle in slot **2**.

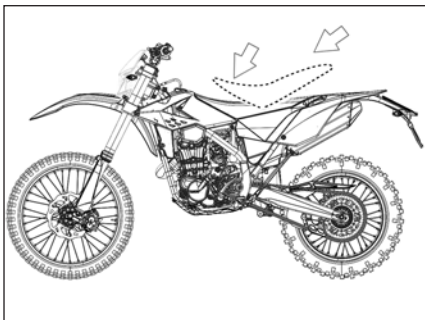

Press the saddle down in the middle and at the same time, push it forwards until the bayonet joint engages in its seat.

WARNING

Make sure the bayonet joint **3** is firmly inserted into the button lock.

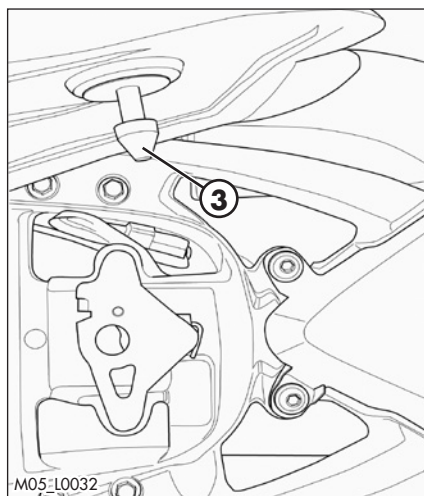
**REMOVING AND INSTALLING AIR FILTER COVER PANEL**

Remove the saddle (page 78).

Grab the side panel in the front side and pull out.

To refit insert the tabs **1** into their slots.

Slide the side panel toward the vehicle.

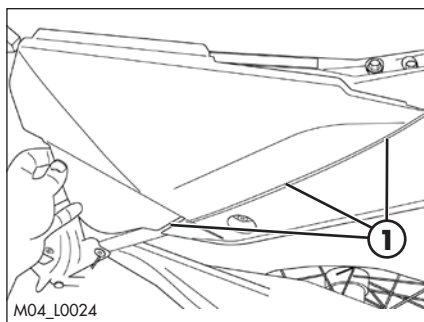

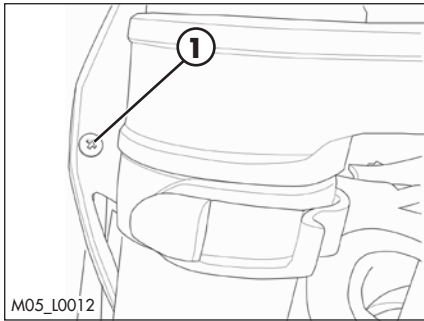

REMOVING AND INSTALLING THE HEADLAMP MASK

Remove the screw **1**.

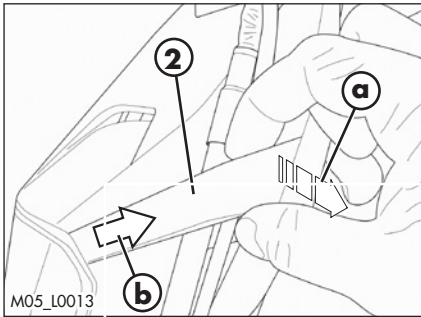

Remove the jumper **2** by pulling the rear portion towards you and slide it towards the rear.

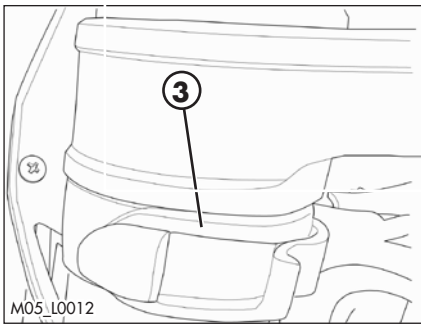

Unhook the elastics **3** (one on each side).

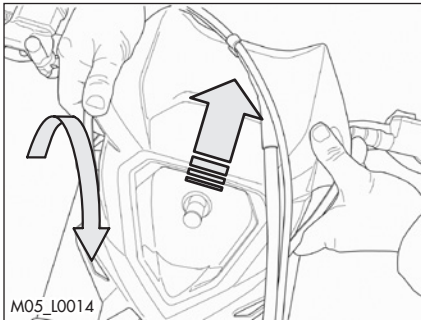

Pull the mask upwards and rotate it forward from the top.

Disconnect all the electric connector attaching the mask to the vehicle.

Remove the mask.

For reassembly, proceed inversely compared to the previously-described disassembly procedures.

CHAPTER 6 TROUBLESHOOTING

CONTENTS

Troubleshooting	82
-----------------------	----

6 TROUBLESHOOTING

TRUBLESHOOTING

PROBLEM	CAUSE	REMEDY
Engine does not start	- Fuel system clogged (fuel lines, fuel tank, fuel cock)	Contact authorised BETAMOTOR customer service
	- Air filter dirty	Check the air filter
	- No current supplied to spark plug	Clean or replace the spark plug. If the problem persists, contact authorised BETAMOTOR customer service
	- Engine flooded	Operate the electrical starter push button 2 times for 5 seconds. If the vehicle does not start, remove and dry the spark plug
	- Excessive distance between the electrodes	Check the distance between the electrodes
	- Ignition connector or coil slackened or oxidized	Clean with a spray product for electric contacts and tighten
	- Presence of water in the carburettor	Empty the carburettor tank
The engine starts but the telltale "MIL" lights on 	- Engine management system fault	Empty the fuel tank and refuel with mixture at 1.6%. Contact authorised BETAMOTOR customer service
Engine misfires	- Spark gap wrongly adjusted	Restore the spark gap
	- Spark plug dirty	Clean or replace the spark plug
The engine does not hold idling	- Idling air jet clogged	Contact authorised BETAMOTOR customer service
	- Adjustment screws poorly adjusted	Adjust
	- Faulty spark plug	Replace the spark plug
	- Faulty ignition system	Check the coil and the spark plug cap
Engine overheats and loses power	- Silencer partly clogged	Contact authorised BETAMOTOR customer service
	- Lamina pack damaged	Contact authorised BETAMOTOR customer service
	- Fault in the ignition system	Contact authorised BETAMOTOR customer service
Excessive smoke	- Possible mixer system fault	Contact authorised BETAMOTOR customer service
Front braking poor	- Brake pads worn	Contact authorised BETAMOTOR customer service
	- Air or humidity in the hydraulic circuit	Follow the procedure described on page 55
Rear braking poor	- Brake pads worn	Contact authorised BETAMOTOR customer service
	- Air or humidity in the hydraulic circuit	Follow the procedure described on page 58

CHAPTER 7 INSTRUCTIONS FOR PERIODIC INSPECTION WORKSHOPS

CONTENTS

Instructions for periodic inspection workshops.....	84
Alphabetical index.....	86

INSTRUCTIONS FOR PERIODIC INSPECTION WORKSHOPS

Instructions for periodic inspection workshops, in accordance with EU regulation 2019/621.

1. BRAKING EQUIPMENT		
ITEM/ASSEMBLY	DOCUMENTARY REFERENCE	REMARKS
1.1.1.3. Brake linings and pads	CHAP. 4 - CHECKS AND MAINTENANCE; PARAGRAPHS "FRONT BRAKE LINING CONTROL", "REAR BRAKE LINING CONTROL"	
1.6. Anti-lock braking system (ABS)		NOT PRESENT
2. STEERING		
2.2.2. Steering column, forks and steering dampers		STEERING DAMPER NOT PRESENT
4. LAMPS, REFLECTORS AND ELECTRICAL EQUIPMENT		
4.1. Headlamps		
4.1.1. Condition and operation	CHAP. 1 - GENERAL INFORMATION; PARAGRAPH "BULBS"	
4.1.2. Alignment		NOT PRESENT
4.1.3. Switching	CHAP. 2 - OPERATION; PARAGRAPH "LH SWITCH"	VEHICLE ELECTRONIC INTERFACE ABSENT
4.1.5. Levelling devices (where mandatory)		NOT MANDATORY
4.2.1. Condition and operation		INSTALLATION OF DAYTIME RUNNING LIGHTS PRESENT
4.1.1. Electrical wiring	CHAP. 1 - GENERAL INFORMATION; PARAGRAPH "ELECTRICAL DIAGRAM"	
4.1.3. Battery	CHAP. 4 - CHECKS AND MAINTENANCE; PARAGRAPH "BATTERY"	
5. AXLES, WHEELS, TYRES AND SUSPENSION		
5.1.1. Axles		TWO-AXIS
5.2.2. Wheels	CHAP. 1 - GENERAL INFORMATION; PARAGRAPH "WHEELS"	
5.2.3. Tyres	CHAP. 1 - GENERAL INFORMATION; PARAGRAPH "TYRES"	

6. CHASSIS AND CHASSIS ATTACHMENTS		
6.1.3. Fuel tank and pipes (including heating fuel tank and pipes)	CHAP. 1 - GENERAL INFORMATION; PARAGRAPH "FAMILIARIZING WITH THE VEHICLE" CHAP. 2 - OPERATION; PARAGRAPHS "FUEL TANK CAP", "FUEL COCK", "MIXER OIL TANK CAP" (IF PRESENT)	
6.1.9. Engine performance		NOT AVAILABLE
7. OTHER EQUIPMENT		
7.1.1. Odometer if available	CHAP. 2 - OPERATION; PARAGRAPH "DASHBOARD OPERATING INSTRUCTIONS"	VEHICLE ELECTRONIC INTERFACE ABSENT
8. NUISANCE		
8.1.1. Noise suppression system	SEE SUMMARY PLATE ON BOARD	
8.2.1.2. Gaseous emissions		NOT APPLICABLE TO 2-STROKE ENGINES

ALPHABETICAL INDEX

Adjusting fork	42
Adjusting the idle speed.....	37
Adjustment of gas clearance.....	37
Air filter	50
Battery.....	68
Brakes	36
Bulbs	16
Carburettor	52
Chain	65
Check and adjusting of steering play.....	62
Checks before and after use	32
Cleaning the vehicle.....	71
Clutch.....	37
Clutch control	60
Dashboard operating instructions	23
Electrical connector maintenance	72
Electrical system.....	14
Engine oil.....	46
Engine shut-down	34
Exhaust valve control adjustment	41
Familiarizing with the vehicle.....	9
Fork.....	64
Front brake.....	54
Front wheel	63
Fuses	16
Fuses	70
Handlebar adjustment	41
Headlight.....	67
Instructions for periodic inspection workshops.....	84

Key to symbols.....	36
Key to symbols.....	46
Liquid coolant.....	47
Main parts	18
Oil mixer refuelling	34
Operating instructions.....	5
Prolonged inactivity.....	73
Rear brake	57
Rear suspension leverage.....	64
Recommended lubricants and liquid	16
Refuelling	33
Removal and refitting of the saddle.....	78
Removing and installing air filter cover panel.....	79
Removing and installing the headlamp mask	80
Replacing the headlight bulbs.....	67
Riding safety	6
Running in.....	32
Scheduled maintenance vehicle	74
Shock absorber.....	43
Spark plug	51
Specifications	10
Starting the engine	34
Symbols.....	5
Tail light.....	68
Tightening torque overview	76
Tools kit	8
Troubleshooting	82
Tyres.....	65
Vehicle identification data	8

