

OWNER'S MANUAL 2009



250 EXC-F EU

250 EXC-F AUS

250 EXC-F SIX DAYS EU

250 XCF-W USA

250 XCF-W ZA

250 XC-F USA

250 SX-F EU

250 SX-F USA

ART. NO. 3211348en

KTM

Congratulations on your decision to purchase a KTM motorcycle. You are now the owner of a state-of-the-art sports motorcycle that will give you enormous pleasure if you service and maintain it accordingly.

We wish you great pleasure riding the vehicle!

Enter the serial numbers of your vehicle below.

Chassis number (☛ p. 10)	Dealer's stamp
Engine number (☛ p. 10)	
Key number (EXC-F, EXC-F SIX DAYS) (☛ p. 10)	

The owner's manual corresponded to the latest state of this series at the time of printing. Slight deviations resulting from continuing development and design of our motorcycles can however not be completely excluded.

All specifications are non-binding. KTM Sportmotorcycle AG specifically reserves the right to modify or delete technical specifications, prices, colors, forms, materials, services, designs, equipment, etc., without prior notice and without specifying reasons, to adapt these to local conditions, as well as to stop production of a particular model without prior notice. KTM accepts no liability for delivery options, deviations from illustrations and descriptions, as well as printing and other errors. The models portrayed partly contain special equipment that does not belong to the regular scope of delivery.

© 2008 by KTM-Sportmotorcycle AG, Mattighofen Austria

All rights reserved

Reproduction, even in part, is permitted only with the express written permission of the copyright owner.



ISO 9001(12 100 6061)









































Within the meaning of the international quality management standard ISO 9001, KTM uses quality assurance processes that lead to the maximum possible quality of the products.

Issued by: TÜV Management Service

REG.NO. 12 100 6061

KTM-Sportmotorcycle AG
5230 Mattighofen, Austria





MEANS OF REPRESENTATION	5	GENERAL TIPS AND HINTS ON PUTTING INTO	
IMPORTANT NOTES	6	OPERATION.....	26
VIEW OF VEHICLE.....	8	Advice on first use.....	26
View of the vehicle from the left front (example)	8	Running in the engine.....	27
View of the vehicle from the right rear (example)	9	RIDING INSTRUCTIONS	28
LOCATION OF SERIAL NUMBERS	10	Checks before putting into operation	28
Chassis number.....	10	Starting	28
Type label.....	10	Starting up	29
Key number (EXC-F, EXC-F SIX DAYS).....	10	Shifting, riding.....	29
Engine number.....	10	Braking	29
Fork part number.....	10	Stopping, parking.....	30
Shock absorber part number	11	Refueling.....	30
CONTROLS	12	SERVICE SCHEDULE (EXC-F, EXC-F SIX DAYS, XCF-W).....	32
Clutch lever	12	Important maintenance work to be carried out by an	
Hand brake lever	12	authorized KTM workshop.	32
Short circuit button (XCF-W, XC-F, SX-F)	12	Important maintenance work to be carried out by an	
Short circuit button (EXC-F, EXC-F SIX DAYS).....	12	authorized KTM workshop (as additional order).....	33
Emergency OFF switch (250 EXC-F AUS)	12	SERVICE SCHEDULE (XC-F, SX-F)	34
Electric starter button (EXC-F EU, EXC-F SIX DAYS,		Important maintenance work to be carried out by an	
XCF-W, XC-F)	13	authorized KTM workshop.	34
Electric starter button (250 EXC-F AUS).....	13	Important maintenance work to be carried out by an	
Light switch (EXC-F, EXC-F SIX DAYS)	13	authorized KTM workshop (as additional order).....	35
Light switch (XCF-W)	13	SERVICE SCHEDULE FOR RIDER.....	36
Horn button (EXC-F, EXC-F SIX DAYS).....	13	Important checks and maintenance work to be carried	
Flasher switch (EXC-F, EXC-F SIX DAYS)	14	out by the rider.	36
Overview of indicator lamps (EXC-F, EXC-F SIX DAYS)	14	MAINTENANCE WORK ON CHASSIS AND ENGINE.....	37
CONTROLS (EXC-F, EXC-F SIX DAYS, XCF-W).....	15	Jacking up the motorcycle.....	37
Speedometer.....	15	Removing the motorcycle from the work stand.....	37
Speedometer activation and test	15	Checking the basic chassis setting with the rider's	
Tripmaster switch	15	weight	37
Setting kilometers or miles	15	Compression damping of shock absorber.....	37
Setting the clock	16	Adjusting high-speed compression damping of the shock	
Adjusting the speedometer functions.....	16	absorber	37
Querying the lap time	17	Adjusting the low-speed compression damping of the	
SPEED display mode (speed).....	17	shock absorber	38
SPEED/H display mode (service hours)	17	Adjusting the rebound damping of the shock absorber.....	39
SPEED/CLK display mode (time).....	18	Measuring rear wheel sag unloaded	40
SPEED/LAP display mode (lap time).....	18	Checking the static sag of the shock absorber	40
SPEED/ODO display mode (odometer)	18	Checking the riding sag of the shock absorber	41
SPEED/TR1 display mode (trip master 1).....	18	Adjusting the spring preload of the shock absorber 🖐️	41
SPEED/TR2 display mode (trip master 2).....	19	Adjusting the riding sag 🖐️.....	42
SPEED/A1 display mode (average speed 1).....	19	Removing the shock absorber 🖐️.....	42
SPEED/A2 display mode (average speed 2).....	19	Installing the shock absorber 🖐️	42
SPEED/S1 display mode (stop watch 1).....	20	Checking basic setting of fork	43
SPEED/S2 display mode (stop watch 2).....	20	Adjusting the compression damping of the fork	43
CONTROLS	22	Adjusting the rebound damping of fork	44
Fuel tap (EXC-F, EXC-F SIX DAYS, XCF-W, XC-F).....	22	Adjusting the spring preload of the fork (EXC-F,	
Fuel tap (SX-F).....	22	EXC-F SIX DAYS, XCF-W)	45
Opening filler cap.....	22	Bleeding fork legs.....	45
Closing filler cap	23	Cleaning dust boots of fork legs	46
Choke (EXC-F EU, EXC-F SIX DAYS).....	23	Loosening the fork protection.....	46
Choke (EXC-F AUS, XCF-W, XC-F, SX-F)	23	Positioning the fork protection	46
Shift lever.....	23	Checking play of steering head bearing	46
Foot brake pedal	24	Adjusting play of steering head bearing 🖐️ (EXC-F EU,	
Kickstarter	24	EXC-F AUS, XCF-W ZA)	47
Side stand (EXC-F, EXC-F SIX DAYS, XCF-W, XC-F)	24	Adjusting play of steering head bearing 🖐️	
Plug-in stand (SX-F)	24	(EXC-F SIX DAYS, XCF-W USA, XC-F, SX-F)	47
Steering lock (EXC-F, EXC-F SIX DAYS)	25	Fork offset (XCF-W USA, XC-F, SX-F).....	48
Locking the steering (EXC-F, EXC-F SIX DAYS).....	25	Setting the fork offset 🖐️ (XCF-W USA, XC-F, SX-F).....	48
Unlocking the steering (EXC-F, EXC-F SIX DAYS).....	25	Removing the fork legs.....	48
		Installing the fork legs 🖐️.....	49
		Removing the fork protector 🖐️.....	50
		Installing the fork protector 🖐️	50

Removing the lower triple clamp  (EXC-F SIX DAYS, XCF-W USA, XC-F, SX-F).....	50	Installing the rear wheel 	73
Removing the lower triple clamp  (EXC-F EU, EXC-F AUS, XCF-W ZA).....	51	Tire condition checking.....	74
Installing the lower triple clamp  (EXC-F SIX DAYS, XCF-W USA, XC-F, SX-F).....	51	Checking tire air pressure.....	75
Installing the lower triple clamp  (EXC-F EU, EXC-F AUS, XCF-W ZA).....	52	Checking spoke tension.....	75
Greasing the steering head bearing 	53	Removing the battery  (EXC-F, EXC-F SIX DAYS, XCF-W, XC-F).....	75
Dismounting the front fender.....	53	Installing the battery  (EXC-F, EXC-F SIX DAYS, XCF-W, XC-F).....	76
Installing the front fender.....	53	Recharging the battery  (EXC-F, EXC-F SIX DAYS, XCF-W, XC-F).....	76
Removing headlight mask with headlight (EXC-F, EXC-F SIX DAYS, XCF-W ZA).....	53	Removing a fuse (EXC-F, EXC-F SIX DAYS, XCF-W, XC-F).....	77
Refitting the headlight mask with the headlight (EXC-F, EXC-F SIX DAYS, XCF-W ZA).....	54	Replacing the fuse (EXC-F, EXC-F SIX DAYS, XCF-W, XC-F).....	77
Dismount the start number plate (XCF-W USA, XC-F, SX-F).....	54	Removing the seat.....	77
Installing the start number plate (XCF-W USA, XC-F, SX-F).....	54	Mounting the seat.....	78
Handlebar position.....	54	Dismounting the fuel tank 	78
Adjusting the handlebar position 	55	Installing the fuel tank 	79
Checking gas Bowden cable route.....	56	Cooling system.....	79
Checking play in the gas Bowden cable.....	56	Checking antifreeze and coolant level.....	80
Adjusting the gas Bowden cable play 	57	Checking the coolant level.....	80
Checking for chain dirt accumulation.....	57	Draining the coolant 	81
Cleaning the chain.....	57	Refilling coolant 	81
Checking the chain tension.....	58	Glass fiber yarn filling of main silencer.....	81
Checking the chain tension when fitting rear wheel.....	58	Removing main silencer.....	82
Checking the rear sprocket / engine sprocket for wear.....	59	Installing the main silencer.....	82
Checking chain wear.....	59	Dismounting the air filter box lid.....	82
Adjusting the chain tension.....	59	Installing the air filter box lid.....	82
Adjusting chain tension - after checking.....	60	Removing the air filter 	83
Adjusting chain tension - fitting rear wheel.....	61	Installing the air filter 	83
Adjusting the chain guide  (EXC-F, EXC-F SIX DAYS, XCF-W, XC-F).....	61	Cleaning air filter 	83
Adjusting the chain guide  (SX-F).....	62	Carburetor - idle.....	84
Adjusting basic position of clutch lever.....	62	Carburetor - adjusting idle 	84
Checking the fluid level of hydraulic clutch.....	62	Emptying the carburetor float chamber 	85
Changing the hydraulic clutch fluid 	63	Checking the engine oil level.....	86
Checking the brake discs.....	64	Changing the engine oil and oil filter, cleaning the oil screen 	86
Checking free travel of hand brake lever.....	64	Draining the engine oil 	86
Adjusting basic position of handbrake lever (XCF-W, XC-F, SX-F).....	64	Cleaning the oil screens 	87
Adjusting free travel of handbrake lever (EXC-F, EXC-F SIX DAYS).....	65	Removing the oil filter 	88
Checking the front brake fluid level.....	65	Installing the oil filter 	88
Adding front brake fluid 	65	Filling up with engine oil 	89
Checking the front brake linings.....	66	Adding engine oil.....	89
Removing the front brake linings 	66	TROUBLESHOOTING.....	90
Installing the front brake linings 	67	CLEANING.....	92
Changing the front brake linings 	67	Cleaning motorcycle.....	92
Checking free travel of foot brake lever.....	68	STORAGE.....	93
Adjusting basic position of footbrake lever 	68	Storage.....	93
Checking the rear brake fluid level.....	69	Putting into operation after storage.....	93
Adding brake fluid for the rear brake 	69	TECHNICAL DATA - ENGINE.....	94
Checking the rear brake linings.....	70	Capacity- engine oil.....	95
Removing rear brake linings 	70	Capacity - coolant.....	95
Installing the rear brake linings 	70	TECHNICAL DATA - ENGINE TIGHTENING TORQUES.....	96
Changing the rear brake linings 	71	TECHNICAL DATA - CARBURETOR.....	98
Removing the front wheel 	72	EXC-F, EXC-F SIX DAYS.....	98
Installing the front wheel 	72	XCF-W, 250 XC-F USA.....	98
Removing rear wheel 	73	SX-F.....	98
		TECHNICAL DATA - CHASSIS.....	99
		Lighting equipment.....	100
		Tires.....	100
		Capacity - fuel.....	100

TECHNICAL DATA - FORK.....	101
EXC-F, EXC-F SIX DAYS, XCF-W	101
250 XC-F USA	101
250 SX-F EU	102
250 SX-F USA	102
TECHNICAL DATA - SHOCK ABSORBER	103
EXC-F, EXC-F SIX DAYS, XCF-W	103
250 XC-F USA	103
250 SX-F EU	104
250 SX-F USA	104
TECHNICAL DATA - CHASSIS TIGHTENING TORQUES	105
WIRING DIAGRAM	106
Wiring diagram (EXC-F EU, EXC-F SIX DAYS).....	106
Wiring diagram (250 EXC-F AUS)	110
Wiring diagram (XCF-W, 250 XC-F USA)	112
Wiring diagram (SX-F).....	114
SUBSTANCES.....	116
AUXILIARY SUBSTANCES.....	117
STANDARDS.....	119
INDEX	120

Symbols used

The symbols used are explained in the following.

-
- | | |
|--|---|
|  | Indicates an expected reaction (e.g. of a work step or a function). |
|  | Indicates an unexpected reaction (e.g. of a work step or a function). |
|  | All work marked with this symbol requires specialist knowledge and technical understanding. In the interest of your own safety, have these jobs done in an authorized KTM workshop! There, your motorcycle will be serviced optimally by specially trained experts using the specialist tools required. |
|  | Identifies a page reference (more information is provided on the specified page). |
-

Formats used

The typographical and other formats used are explained in the following.

-
- | | |
|----------------------|--|
| Specific name | Identifies a specific name. |
| Name® | Identifies a protected name. |
| Brand™ | Identifies a brand in merchandise traffic. |
-

Use definition (EXC-F, EXC-F SIX DAYS)

KTM sport motorcycles are designed and built to withstand the normal stresses and strains of competitive use. The motorcycles comply with currently valid regulations and categories of the top international motorsport organizations.

i Info

The motorcycle is authorized for public road traffic in the homologous (reduced) version only.
In the derestricted version, the motorcycle must be used only on secluded property remote from public road traffic.
The motorcycle is designed for off-road sport endurance competition (Enduro) and not for the predominant motocross use.

Use definition (XCF-W, XC-F, SX-F)

KTM sport motorcycles are designed and built to withstand the normal stresses and strains of competitive use. The motorcycles comply with currently valid regulations and categories of the top international motorsport organizations.

i Info

The motorcycle must be used only on secluded property remote from public road traffic.
The motorcycle is designed for off-road sport endurance competition (Enduro) and not for the predominant motocross use.

Maintenance

A prerequisite for perfect operation and prevention of wear is that the engine and chassis maintenance and adjustment work described in the owner's manual are properly carried out. Poor adjustment and tuning of the engine and chassis can lead to damage and breakage of components.

Using the motorcycle in extreme conditions such as very muddy or wet terrain can lead to above-average wear of components such as the transmission train or the brakes. For this reason, it may be necessary to service or replace worn parts before the limit specified in the service schedule is reached.

Pay careful attention to the prescribed running-in period, inspection and maintenance intervals. If you observe these exactly, you will ensure a much longer service life for your motorcycle.

Warranty

The work prescribed in the service schedule must be carried out in an authorized KTM workshop and confirmed in the customer's service record, since otherwise no warranty claims will be recognized. No warranty claims can be considered for damage resulting from manipulations and/or alterations to the vehicle.

Fuel, oils, etc.

You should use the fuels, oils and greases according to specifications as listed in the owner's manual.

Spare parts, accessories

For your own safety, only use spare parts and accessory products that are approved and/or recommended by KTM and have them installed by an authorized KTM workshop. KTM accepts no liability for other products and any resulting damage or loss.

The current **KTM PowerParts** for your vehicle can be found on the KTM website.
International KTM Website: <http://www.ktm.com>

Work rules

When the vehicle is assembled, non-reusable parts (e.g., self-locking screws and nuts, gaskets, seal rings, O-rings, splints, lock washers) must be replaced with new parts.

Where thread lockers are used on screw connections (e.g., **Loctite**®), follow the instructions for use from the manufacturer.

After disassembly, clean the parts that are to be reused and check them for damage and wear. Replace damaged or worn parts.

After you complete the repair or maintenance work, check the roadworthiness of the vehicle.

Transport

Note

Danger of damage Danger of damage by the vehicle running away or falling over.

- Always place the vehicle on a firm and even surface.

Note

Fire hazard Some components (engine, radiator and exhaust system) get very hot when the engine is running.

- Do not place the vehicle where there are flammable or explosive substances.

- Switch off the engine.

(EXC-F, EXC-F SIX DAYS, XCF-W, XC-F)

- Turn handle ❶ of the fuel tap to the **OFF** position. (Figure 500137-10☛ p. 22)

(SX-F)

- Turn handle ❶ of the fuel tap to the **OFF** position. (Figure 500178-10☛ p. 22)
- Use straps or other suitable devices to secure the motorcycle against accidents or falling over.

Environment

Offroad motorcycling is a wonderful sport and we naturally hope that you will be able to enjoy it to the fullest. However, it is a potential problem for the environment and can lead to conflicts with other persons. But if you use your motorcycle responsibly, you can ensure that such problems and conflicts do not have to occur. To protect the future of motorcycle sport, make sure that you use your motorcycle legally, display environmental consciousness, and respect the rights of others.

Notes/warnings

Be sure to pay attention to the notes and warnings given here.

Info

Various notes and warning stickers are attached to the vehicle. Do not remove any notes and warning stickers. If they are missing, you or others may not recognize dangers and may therefore be injured.

Grades of risks

Danger

Danger that leads immediately and certainly to severe and permanent injury or death.

Warning

Danger that will probably lead to severe and permanent injury or death.

Note

Danger of serious damage to machine or material.

Warning

Risk of environmental damage.

OWNER'S MANUAL

- It is important that you read this owner's manual carefully and completely before making your first trip. It contains useful information and many tips on how to operate and handle your motorcycle. Only then will you find out how to best customize the motorcycle for your own use and how you can protect yourself from injury. The owner's manual also contains important information on servicing the motorcycle.
- The owner's manual is an important component of the motorcycle and should be handed over to the new owner if the vehicle is sold.

View of the vehicle from the left front (example)



600657-10

1	Hand brake lever
2	Filler cap
3	Clutch lever
4	Fuel tap
5	Shift lever
6	Air filter box lid
7	Chain guide

View of the vehicle from the right rear (example)



600656-10

- | | |
|---|--|
| 1 | Rubber band for the side stand |
| 2 | Shock absorber, compression adjustment |
| 3 | Chassis number |
| 4 | Fork protector |
| 5 | Shock absorber, rebound adjustment |
| 6 | Level viewer, rear brake fluid |
| 7 | Level viewer, engine oil |
| 8 | Kickstarter |

Chassis number

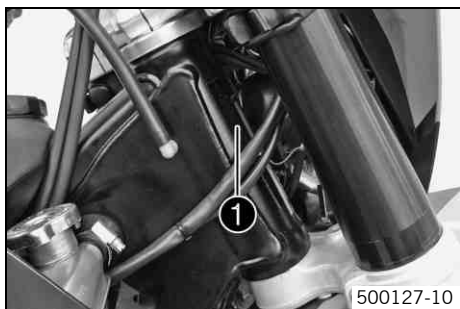

The chassis number ❶ is stamped on the steering head on the right.

Type label



The type label ❶ is fixed to the front of the steering head.

Key number (EXC-F, EXC-F SIX DAYS)

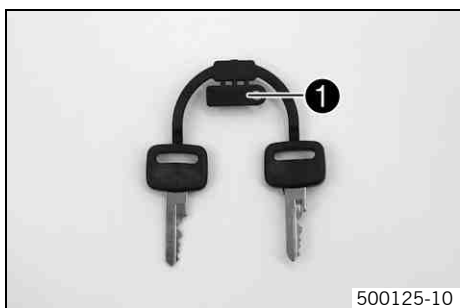

The key number ❶ is stamped on the key strap.

Engine number



The engine number ❶ is stamped on the left side of the engine under the engine sprocket.

Fork part number

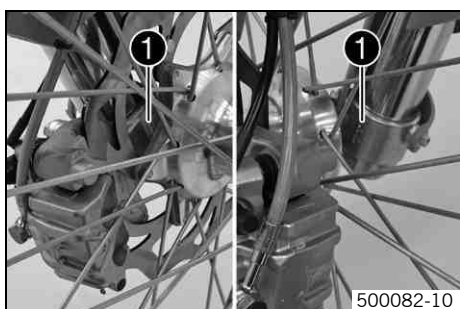

The fork part number ❶ is stamped on the inner side of the fork stub.

Shock absorber part number

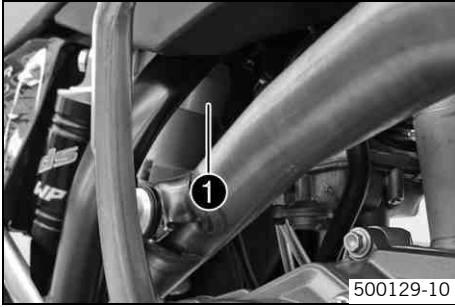

The shock absorber part number ❶ is stamped on the top of the shock absorber above the adjusting ring on the engine side.

500129-10

Clutch lever

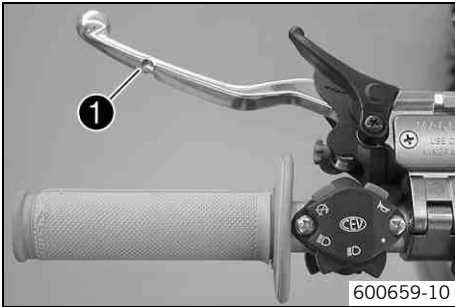

The clutch lever ❶ is fitted on the left side of the handlebar. The clutch is hydraulically operated and self-adjusting.

Hand brake lever

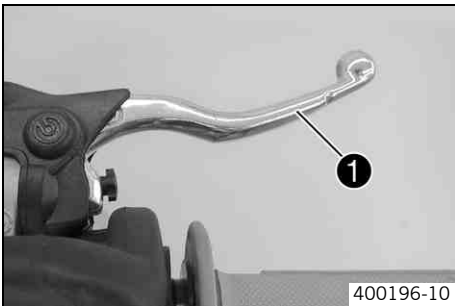

Hand brake lever ❶ is located on the right side of the handlebar. The hand brake lever is used to activate the front brake.

Short circuit button (XCF-W, XC-F, SX-F)

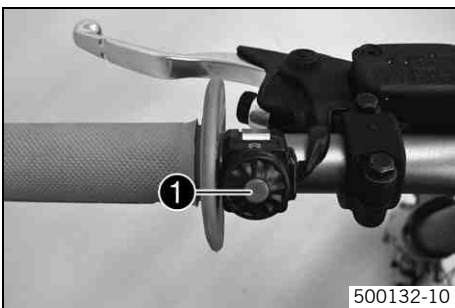

The short circuit button ❶ is fitted on the left side of the handlebar.

Possible states

- Short circuit button ☒ in basic position – In this position, the ignition circuit is closed, and the engine can be started.
- Short circuit button ☒ pressed – In this position, the ignition circuit is interrupted, a running engine stops, and a non-running engine will not start.

Short circuit button (EXC-F, EXC-F SIX DAYS)

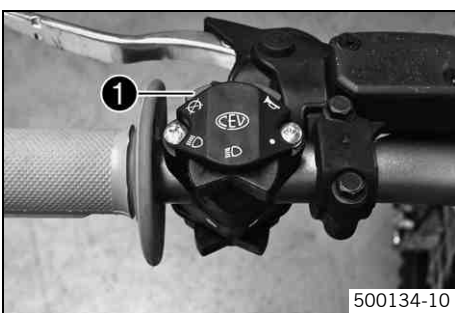

The short circuit button ❶ is fitted on the left side of the handlebar.

Possible states

- Short circuit button ☒ in basic position – In this position, the ignition circuit is closed, and the engine can be started.
- Short circuit button ☒ pressed – In this position, the ignition circuit is interrupted, a running engine stops, and a non-running engine will not start.

Emergency OFF switch (250 EXC-F AUS)



The emergency OFF switch ❶ is fitted on the left side of the handlebar.

Possible states

- ☒ Ignition off – In this position, the ignition circuit is interrupted, a running engine stops, and a non-running engine will not start.
- ☑ Ignition on – In this position, the ignition circuit is closed, and the engine can be started.

Electric starter button (EXC-F EU, EXC-F SIX DAYS, XCF-W, XC-F)

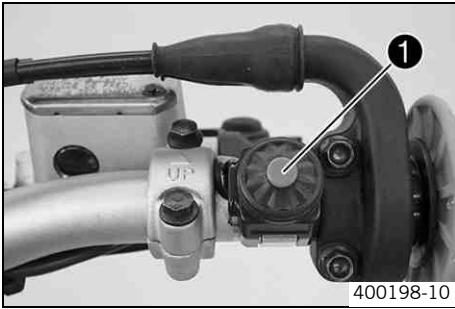

The electric starter button ❶ is fitted on the right side of the handlebar.

Possible states

- Electric starter button ❶ in basic position
- Electric starter button ❶ pressed – In this position, the electric starter is actuated.

Electric starter button (250 EXC-F AUS)



The electric starter button ❶ is fitted on the right side of the handlebar.

Possible states

- Electric starter button ❶ in basic position
- Electric starter button ❶ pressed – In this position, the electric starter is actuated.

Light switch (EXC-F, EXC-F SIX DAYS)

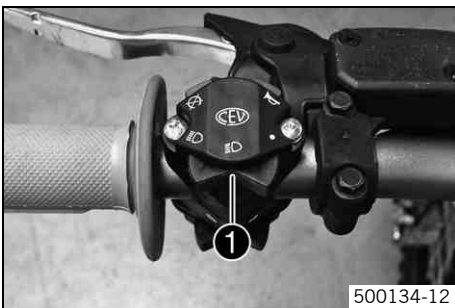

The light switch ❶ is fitted on the left side of the handlebar.

Possible states

- Light off – Light switch is turned to the right. In this position, the light is switched off.
- Low beam on – Light switch is in the central position. In this position, the low beam and tail light are switched on.
- High beam on – Light switch is turned to the left. In this position, the high beam and the tail light are switched on.

Light switch (XCF-W)



The light switch ❶ is on the right of the speedometer.

Possible states

(250 XCF-W ZA)

- Light off – Light switch is pressed in up to the stop. In this position, the light is switched off.
- Light on – Light switch is pulled out to the stop. In this position, the low beam and the tail light are switched on.

(250 XCF-W USA)

- The light switch has no function when delivered. – It can be used if lighting is fitted later.

Horn button (EXC-F, EXC-F SIX DAYS)

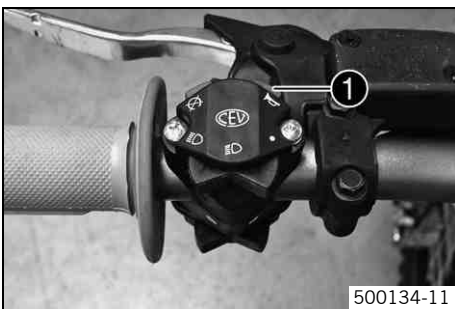

The horn button ❶ is fitted on the left side of the handlebar.

Possible states

- Horn button ❶ in neutral position
- Horn button ❶ pressed – The horn is operated in this position.

Flasher switch (EXC-F, EXC-F SIX DAYS)

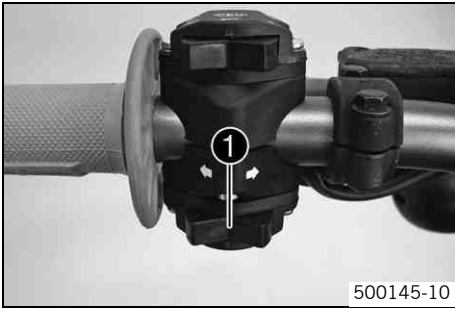

Flasher switch ❶ is fitted on the left side of the handlebar.

Possible states



Flasher light off – Flasher switch is in the central position.
Flasher light, left, on – Flasher switch turned to the left.

Flasher light, right, on – Flasher switch turned to the right.

Overview of indicator lamps (EXC-F, EXC-F SIX DAYS)



Possible states



High beam indicator lamp lights up blue – High beam is switched on.

Flasher indicator lamp flashes green – Flasher light is switched on.

Speedometer

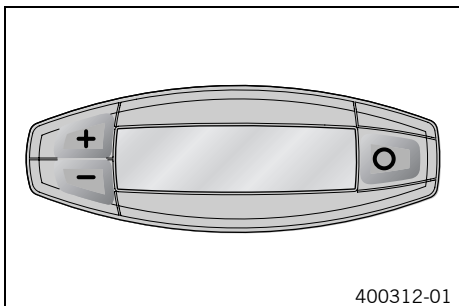

- Press the key to change the display mode or change to one of the setup menus.
- Press the button to control different functions.
- Press the button to control different functions.

i Info
In its condition at delivery, the display mode **SPEED/H** and **SPEED/ODO** is activated.

Speedometer activation and test

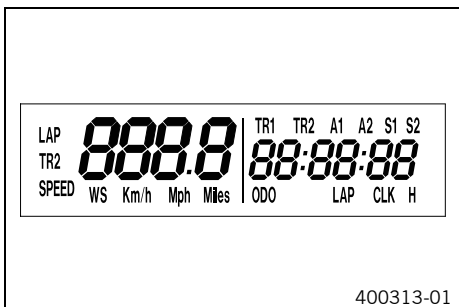

Activating the speedometer:
The speedometer is activated when one of the keys is pressed or an impulse comes from the wheel speed sensor.

Display test

For the function test of the display, all display segments light up briefly.

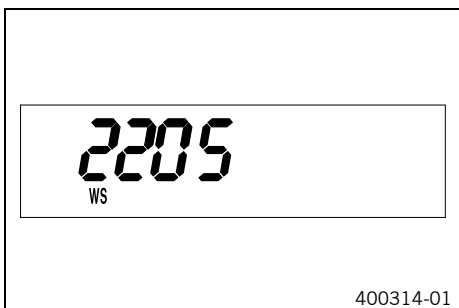

WS (wheel size)

After the display function test, the wheel size **WS** is displayed briefly.

i Info
2205 mm corresponds to the size of the 21" front wheel with a series production tire.

The display then changes to the last selected mode.

Tripmaster switch

(Option: Tripmaster switch)

You can use the trip master switch to control the functions of the speedometer from the handlebar.

i Info
The trip master is an optional accessory.

Setting kilometers or miles

i Info
If you change the unit of measure, the **ODO** value is retained and converted accordingly. The values **TR1**, **TR2**, **A1**, **A2** and **S1** are cleared when the unit of measure is changed.

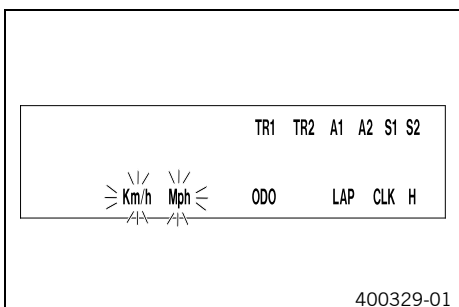

Condition

The motorcycle is standing.

- Press the button briefly and repeatedly until **H** appears at the bottom right of the display.
- Press the button for 3 - 5 seconds.
 - ✓ The Setup menu opens and the active functions are displayed.
- Press the button repeatedly until the **Km/h/Mph** display flashes.

Adjusting Km/h

- Press the button .

Adjusting Mph

- Press the button .

- Press the button  for 3 - 5 seconds.
- ✓ The settings are saved and the Setup menu closed.





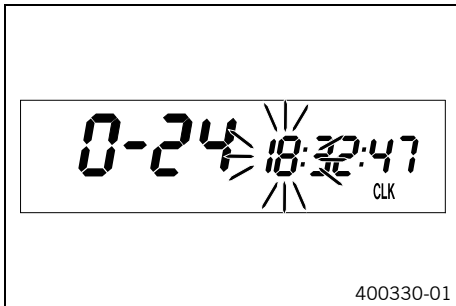

i Info
If no button is pressed for 20 seconds, or if no impulse comes from the wheel speed sensor, the settings are automatically saved and the Setup menu is closed.

Setting the clock



Condition

The motorcycle is standing.

- Press the button  briefly and repeatedly until **CLK** appears at the bottom right of the display.
- Press the button  for 3 - 5 seconds.
- ✓ The hour display flashes.
- Set the hour display with the button  and/or button .
- Press the button  briefly.
- ✓ The next segment of the display flashes and can be set.
- You can set the following segments in the same way as the hours by pressing the button  and the button .

i Info
The seconds can only be set to zero.

- Press the button  for 3 - 5 seconds.
- ✓ The settings are saved and the Setup menu closed.

i Info
If no button is pressed for 20 seconds, or if no impulse comes from the wheel speed sensor, the settings are automatically saved and the Setup menu is closed.

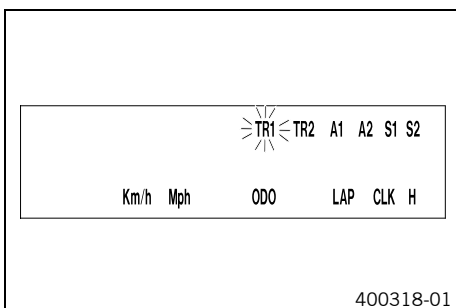

Adjusting the speedometer functions

i Info
Upon delivery, only the **SPEED/H** and **SPEED/ODO** display modes are activated.



Condition

The motorcycle is standing.

- Press the button  briefly and repeatedly until **H** appears at the bottom right of the display.
- Press the button  for 3 - 5 seconds.
- ✓ The Setup menu opens and the active functions are displayed.
- Switch to the function you require by briefly pressing the button .
- ✓ The selected function flashes.

Activating a function

- Press the button .
- ✓ The icon remains in the display and the display changes to the next function.

Deactivating a function

- Press the button .
- ✓ The icon disappears from the display and the display changes to the next function.
- Activate or deactivate all functions accordingly.

- Press the button  for 3 - 5 seconds.
- ✓ The settings are saved and the Setup menu closed.

i Info
If no button is pressed for 20 seconds, or if no impulse comes from the wheel speed sensor, the settings are automatically saved and the Setup menu is closed.



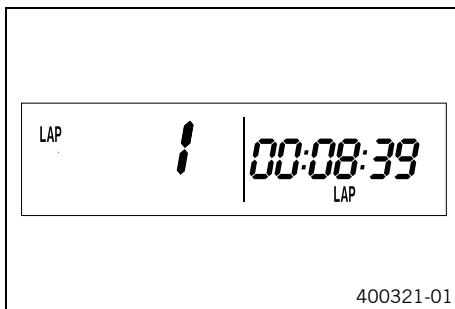

Querying the lap time

i Info
This function can be called only if lap times are measured.



Condition

The motorcycle is standing.

- Press the button  briefly and repeatedly until **LAP** appears at the bottom right of the display.
- Press the button  briefly.
- ✓ **LAP 1** appears on the left side of the display.
- Laps 1-10 can be displayed by pressing the button .
- The  button has no function
- Press the button  briefly.
- ✓ Next display mode

i Info
If an impulse is received from the wheel speed sensor, the left side of the display changes back to the **SPEED** mode.

SPEED display mode (speed)



- Press the button  briefly and repeatedly until **SPEED** appears on the left side of the display.

The current speed is displayed in the **SPEED** display mode.
The current speed can be displayed in **Km/h** or **Mph**.

i Info
Making the setting according to the country.
When an impulse comes from the front wheel, the left side of the speedometer display changes to the **SPEED** mode and the current speed is shown.

SPEED/H display mode (service hours)





Condition

- Vehicle at a standstill
- Press the button  briefly and repeatedly until **H** appears at the bottom right of the display.

The number of service hours of the engine is shown in the **H** display mode.
The service hour counter stores the total traveling time.

i Info
The service hour counter is necessary for ensuring that maintenance work is carried out at the right intervals.
If the speedometer is in the **H** display mode at the start of the trip, it automatically changes to the **ODO** display mode.
The **H** display mode is suppressed during travel.

- Press the button  No function
- Press the button  No function
- Press the button  The display changes to the Setup menu of the speedometer for 3 - 5 seconds.



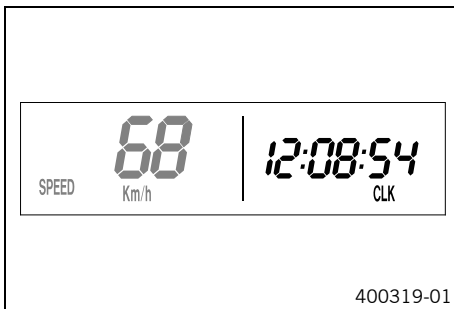

Press the button  next display mode briefly.

SPEED/CLK display mode (time)



– Press the button  briefly and repeatedly until **CLK** appears at the bottom right of the display.

The time is displayed in the **CLK** display mode.



- Press the button  No function
- Press the button  No function
- Press the button  The display changes to the Setup menu of the clock. for 3 - 5 seconds.
- Press the button  next display mode briefly.





SPEED/LAP display mode (lap time)



– Press the button  briefly and repeatedly until **LAP** appears at the bottom right of the display.

In the **LAP** display mode, up to ten laps can be timed with the stop watch.

i Info
If the lap time continues after you press the button , 9 memory locations are already occupied.
Lap 10 must be timed with the button .



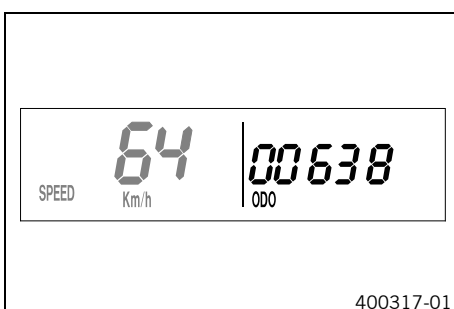

- Press the button  Starts or stops the clock.
- Press the button  Stops the current lap time and saves it, and the stop watch starts the next lap.
- Press the button  The stop watch and the lap time are reset. for 3 - 5 seconds.
- Press the button  next display mode briefly.

SPEED/ODO display mode (odometer)



– Press the button  briefly and repeatedly until **ODO** appears at the bottom right of the display.

The total number of kilometers ridden is shown in the **ODO** display mode.

- Press the button  No function
- Press the button  No function
- Press the button  – for 3 - 5 seconds.
- Press the button  next display mode briefly.

SPEED/TR1 display mode (trip master 1)







– Press the button  briefly and repeatedly until **TR1** appears at the top right of the display.

TR1 (trip master 1) runs constantly and counts to 999.9.

You can use it to measure trips or the distance between refueling stops.

TR1 is coupled with **A1** (average speed 1) and **S1** (stop watch 1).

i Info
If 999.9 is exceeded, the values of **TR1**, **A1** and **S1** are automatically reset to 0.0.

- Press the button  No function
- Press the button  No function
- Press the button  The **TR1**, **A1** and **S1** displays are reset to 0.0. for 3 - 5 seconds.
- Press the button  next display mode briefly.

SPEED/TR2 display mode (trip master 2)

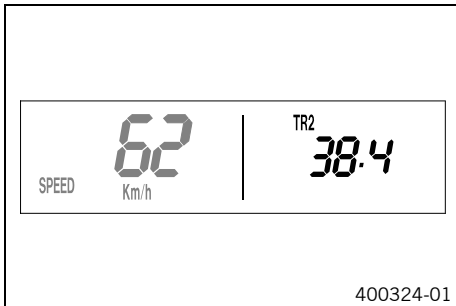

- Press the button briefly and repeatedly until **TR2** appears at the top right of the display.

TR2 (trip master 2) runs constantly and counts to 999.9.

The displayed value can be set manually with the button and the button . A very practical function for rides by the road book.

Info

The **TR2** value can also be corrected manually during the trip using the button and the button . If 999.9 is exceeded, **TR2** is automatically reset to 0.0.

- Press the button . Increases value **TR2**.
- Press the button . Decreases value **TR2**.
- Press the button . Clears value **TR2** for 3 - 5 seconds.
- Press the button next display mode briefly.

SPEED/A1 display mode (average speed 1)



- Press the button briefly and repeatedly until **A1** appears at the top right of the display.

A1 (average speed 1) shows the average speed calculated on the basis of **TR1** (trip master 1) and **S1** (stop watch 1).

The calculation of this value is activated by the first impulse of the wheel speed sensor and ends 3 seconds after the last impulse.

- Press the button . No function
- Press the button . No function
- Press the button . The **TR1**, **A1** and **S1** displays are reset to 0.0. for 3 - 5 seconds.
- Press the button next display mode briefly.

SPEED/A2 display mode (average speed 2)



- Press the button briefly and repeatedly until **A2** appears at the top right of the display.

A2 (average speed 2) shows the average speed on the basis of the current speed if the stop watch **S2** (stop watch 2) is running.

Info

The displayed value can differ from the actual average speed if **S2** is not stopped after the ride.

- Press the button . No function
- Press the button . No function
- Press the button . – for 3 - 5 seconds.
- Press the button next display mode briefly.

SPEED/S1 display mode (stop watch 1)



– Press the button briefly and repeatedly until **S1** appears at the top right of the display.

S1 (stop watch 1) shows the trip time on the basis of **TR1** and continues running when an impulse is received from the wheel speed sensor. The calculation of this value starts with the first impulse of the wheel speed sensor and ends three seconds after the last impulse.

- Press the button . No function
- Press the button . No function
- Press the button . The **TR1**, **A1** and **S1** displays are reset to 0.0. for 3 - 5 seconds.
- Press the button next display mode briefly.

SPEED/S2 display mode (stop watch 2)



– Press the button briefly and repeatedly until **S2** appears at the top right of the display.

S2 (stop watch 2) is a manual stop watch. If **S2** is running in the background, the **S2** display flashes in the speedometer display.

- Press the button . Starts or stops **S2**.
- Press the button . No function
- Press the button . The **S2** and **A2** displays are reset to 0.0. for 3 - 5 seconds.
- Press the button next display mode briefly.

Table of functions

Display	Press the button .	Press the button .	Press the button for 3 - 5 seconds.	Press the button briefly.
SPEED/H display mode (service hours)	No function	No function	The display changes to the Setup menu of the speedometer functions.	next display mode
SPEED/CLK display mode (time)	No function	No function	The display changes to the Setup menu of the clock.	next display mode
SPEED/LAP display mode (lap time)	Starts or stops the clock.	Stops the current lap time and saves it, and the stop watch starts the next lap.	The stop watch and the lap time are reset.	next display mode
SPEED/ODO display mode (odometer)	No function	No function	–	next display mode
SPEED/TR1 display mode (trip master 1)	No function	No function	The TR1 , A1 and S1 displays are reset to 0.0.	next display mode
SPEED/TR2 display mode (trip master 2)	Increases value TR2 .	Decreases value TR2 .	Clears value TR2 .	next display mode
SPEED/A1 display mode (average speed 1)	No function	No function	The TR1 , A1 and S1 displays are reset to 0.0.	next display mode
SPEED/A2 display mode (average speed 2)	No function	No function	–	next display mode
SPEED/S1 display mode (stop watch 1)	No function	No function	The TR1 , A1 and S1 displays are reset to 0.0.	next display mode
SPEED/S2 display mode (stop watch 2)	Starts or stops S2 .	No function	The S2 and A2 displays are reset to 0.0.	next display mode

Table of conditions and activability

Display	Vehicle at a stand-still	Menu can be activated
SPEED/H display mode (service hours)	•	
SPEED/CLK display mode (time)		•
SPEED/LAP display mode (lap time)		•

Table of conditions and activability		
Display	Vehicle at a stand-still	Menu can be activated
SPEED/TR1 display mode (trip master 1)		•
SPEED/TR2 display mode (trip master 2)		•
SPEED/A1 display mode (average speed 1)		•
SPEED/A2 display mode (average speed 2)		•
SPEED/S1 display mode (stop watch 1)		•
SPEED/S2 display mode (stop watch 2)		•

Fuel tap (EXC-F, EXC-F SIX DAYS, XCF-W, XC-F)



The fuel tap is on the left side of the fuel tank. Using tap handle ❶ on the fuel tap, you can open or close the supply of fuel to the carburetor.

Possible states

- Fuel supply closed **OFF** – No fuel can flow from the tank to the carburetor.
- Fuel supply open **ON** – Fuel can flow from the tank to the carburetor. The fuel tank empties down to the reserve.
- Reserve fuel supply open **RES** – Fuel can flow from the tank to the carburetor. The fuel tank empties completely.



500137-10

Fuel tap (SX-F)



The fuel tap is on the left side of the fuel tank. Using tap handle ❶ on the fuel tap, you can open or close the supply of fuel to the carburetor.

Possible states

- Fuel supply closed **OFF** – No fuel can flow from the tank to the carburetor.
- Fuel supply open **ON** – Fuel can flow from the tank to the carburetor. The fuel tank empties completely.

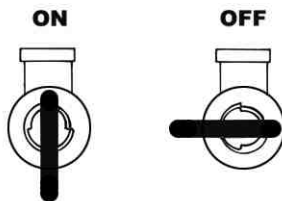

500178-10

Opening filler cap

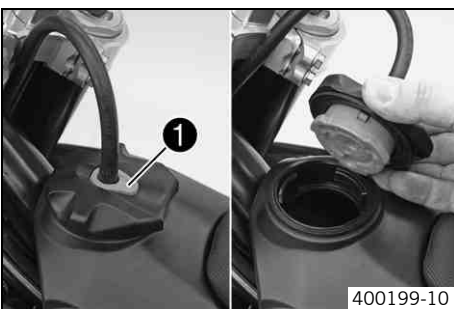

400199-10

- Press release button ❶, turn filler cap counterclockwise and lift it free.

Closing filler cap

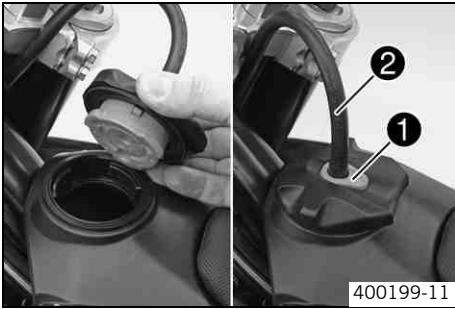

400199-11

- Replace the filler cap and turn clockwise until the release button ❶ locks in place.

i Info

Run the fuel tank breather hose ❷ without kinks.

Choke (EXC-F EU, EXC-F SIX DAYS)

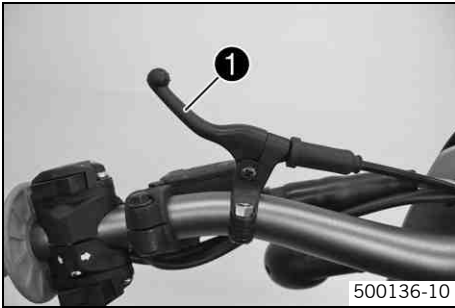

500136-10

The flasher switch ❶ is fitted on the left side of the handlebar. Activating the choke function frees an opening through which the engine can draw extra fuel. This gives a richer fuel-air mixture, which is needed for a cold start.

i Info

If the engine is warm, the choke function must be deactivated.

Possible states

- Choke function activated – The choke lever is pulled to the stop.
- Choke function deactivated – The choke lever is pushed back to the stop.

Choke (EXC-F AUS, XCF-W, XCF, SX-F)

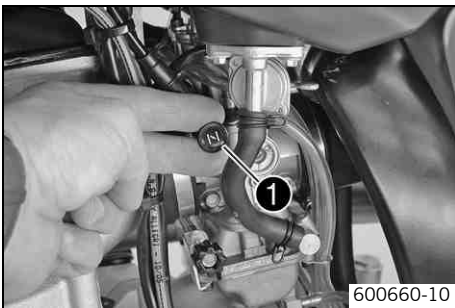

600660-10

Choke ❶ is fitted on the left side of the carburetor. Activating the choke function frees an opening through which the engine can draw extra fuel. This gives a richer fuel-air mixture, which is needed for a cold start.

i Info

If the engine is warm, the choke function must be deactivated.

Possible states

- Choke function activated – The choke lever is pulled out to the stop.
- Choke function deactivated – The choke lever is pushed in to the stop.

Shift lever

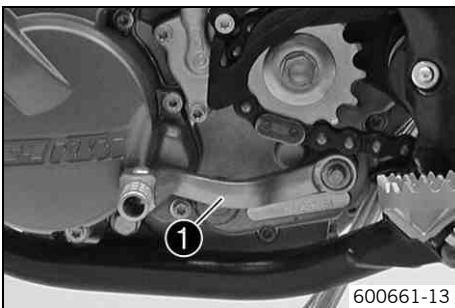

600661-13

Shift lever ❶ is mounted on the left side of the engine.

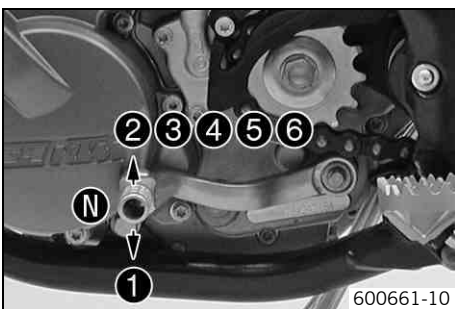

600661-10

The gear positions can be seen in the photograph. The neutral or idle position is between the first and second gears.

Foot brake pedal

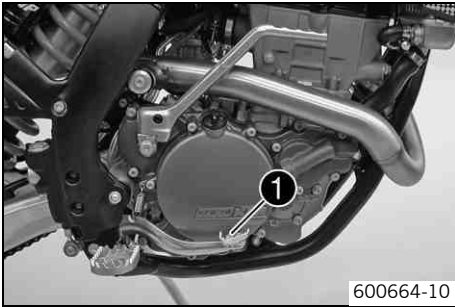

Foot brake pedal ❶ is located in front of the right footrest. The foot brake pedal is used to activate the rear brake.

Kickstarter

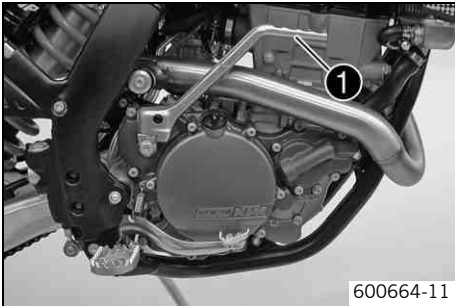

Kickstarter ❶ is fitted on the right of the engine. The engine can be started with either the kickstarter or the electric starter. The upper part of the kickstarter can be swung out.

i Info

Before riding, swing the upper part of the kickstarter inward toward the engine.

Side stand (EXC-F, EXC-F SIX DAYS, XCF-W, XC-F)



Note

Danger of damage Danger of damage by the vehicle running away or falling over.

- Always place the vehicle on a firm and even surface.

Note

Material damage Damage and destruction of components by excessive load.

- The side stand is designed for the weight of the motorcycle only. Do not sit on the motorcycle when it is supported by the side stand only. The side stand and/or the frame could be damaged and the motorcycle could fall over.

To park the motorcycle, press the side stand ❶ to the ground with your foot and lean the motorcycle on it.

When you are riding, the side stand ❶ must be folded up and secured with the rubber band ❷.

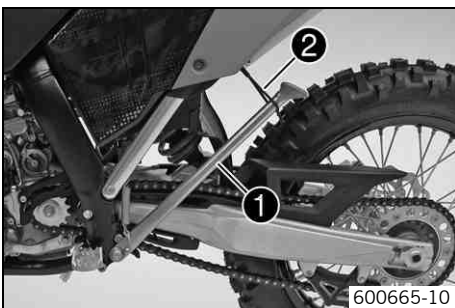

Plug-in stand (SX-F)

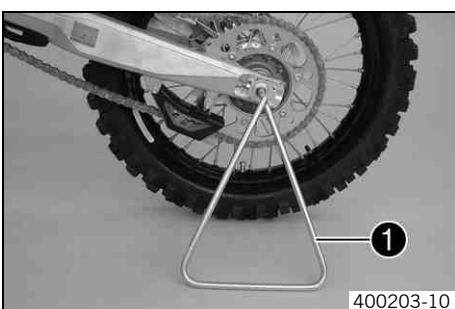

Note

Danger of damage Danger of damage by the vehicle running away or falling over.

- Always place the vehicle on a firm and even surface.

To park the motorcycle, insert plug-in stand ❶ into the left side of the wheel spindle.

i Info

Remove the plug-in stand before starting on a trip.

Steering lock (EXC-F, EXC-F SIX DAYS)



Steering lock ❶ is fitted on the left side of the steering head. The steering lock is used to lock the steering. Steering, and therefore riding, is no longer possible.

Locking the steering (EXC-F, EXC-F SIX DAYS)

Note

Danger of damage Danger of damage by the vehicle running away or falling over.

- Always place the vehicle on a firm and even surface.
-
- Park the motorcycle.
 - Turn the handlebar as far as possible to the right.
 - Insert the key in the steering lock, turn it to the left, press it in and turn it to the right. Remove the key.
 - ✓ Steering is no longer possible.



Info

Never leave the key in the steering lock.

Unlocking the steering (EXC-F, EXC-F SIX DAYS)









- Insert the key in the steering lock, turn it to the left, pull it out and turn it to the right. Remove the key.
- ✓ You can now steer the bike again.



Info

Never leave the key in the steering lock.

Advice on first use

-  **Danger**
Danger of accidents Danger from insufficient traffic competence.
 - Do not use the vehicle if you are not fit to deal with traffic or if you have consumed alcohol and/or medicaments or drugs.
-  **Warning**
Risk of injury Risk of injury by missing/inadequate protective clothing.
 - Wear protective clothing (helmet, boots, gloves, pants and jacket with protectors) every time you ride the vehicle. Always wear protective clothing, which must be in perfect condition and meet legal requirements.
-  **Warning**
Danger of crashing Impairment of riding behavior due to different tire tread patterns on front and rear wheels.
 - The front and rear wheels must be fitted with tires with similar tread patterns to prevent loss of control over the vehicle.
-  **Warning**
Danger of accidents Critical riding behavior due to inappropriate riding.
 - Adapt your riding speed to the road conditions and your riding ability.
-  **Warning**
Danger of accidents Accident risk caused by presence of a passenger.
 - Your vehicle is not designed to carry passengers. Do not ride with a passenger.
-  **Warning**
Danger of accidents Brake system failure.
 - If the foot brake pedal is not released, the brake linings drag permanently. The rear brake can fail due to overheating. Take your foot off the foot brake pedal if you do not want to brake.
-  **Warning**
Danger of accidents Unstable riding behavior.
 - Do not exceed the maximum permitted weight and axle loads.
-  **Warning**
Risk of misappropriation Usage by unauthorized persons.
 - Never leave the vehicle while the engine is running. Secure the vehicle against use by unauthorized persons.

 **Info**
When using your motorcycle, remember that others may feel disturbed by excessive noise.

-
- Make sure that the pre-delivery inspection work has been carried out by an authorized KTM workshop. You receive a delivery certificate and the service record at vehicle handover.
 - Before your first trip, read the entire operating instructions carefully.
 - Get to know the controls.
 - Adjust the basic position of clutch lever. (☛ p. 62)

(XCF-W, XC-F, SX-F)

- Adjust the basic position of handbrake lever. (☛ p. 64)

(EXC-F, EXC-F SIX DAYS)

- Adjust the free travel of the handbrake lever. (☛ p. 65)
- Adjust the basic position of the footbrake lever. ☛ (☛ p. 68)
- Get used to handling the motorcycle on a suitable piece of land before making a longer trip.

 **Info**
Offroad, you should be accompanied by another person on another machine so that you can help each other.

-
- Try also to ride as slowly as possible and in a standing position to get a better feeling for the vehicle.
 - Do not make any offroad trips that over-stress your ability and experience.
 - Hold the handlebar firmly with both hands and keep your feet on the footrests when riding.

- If you carry any baggage, make sure it is fixed firmly as close as possible to the center of the vehicle and ensure even weight distribution between the front and rear wheels.



Info

Motorcycles react sensitively to any changes of weight distribution.

- Do not exceed the overall maximum permitted weight and the axle loads.

Guideline

Maximum permissible overall weight	335 kg (739 lb.)
Maximum permissible front axle load	145 kg (320 lb.)
Maximum permissible rear axle load	190 kg (419 lb.)

- Run the engine in.

Running in the engine

- During the running-in phase, do not exceed the specified engine speed and engine performance.

Guideline

Maximum engine speed	
During the first 3 service hours	7,000 rpm
Maximum engine performance during the running-in period	
During the first 3 service hours	≤ 50 %
During the next 12 service hours	≤ 75 %

- Avoid fully opening the throttle!

Checks before putting into operation



Info

Make sure that the motorcycle is in a perfect technical condition before use.



Info

In the interests of riding safety, make a habit of making a general check before you ride.

- Check the engine oil level. (☛ p. 86)
- Check the chain tension. (☛ p. 58)
- Check for chain dirt accumulation. (☛ p. 57)
- Check the tire condition. (☛ p. 74)
- Check the tire air pressure. (☛ p. 75)
- Check the front brake fluid level. (☛ p. 65)
- Check the rear brake fluid level. (☛ p. 69)
- Check the front brake linings. (☛ p. 66)
- Check the rear brake linings. (☛ p. 70)
- Check brake system function.
- Check the coolant level. (☛ p. 80)
- Check that all operating elements are correctly adjusted and free to move.
- Check the functioning of the electrical equipment.

Starting



Danger

Danger of poisoning Exhaust gases are poisonous and can result in unconsciousness and/or death.

- When running the engine, always make sure there is sufficient ventilation, and do not start or run the engine in a closed space.

Note

Engine failure High engine speeds in cold engines have a negative effect on the service life of the engine.

- Always warm up the engine at low engine speeds.



Info

If the motorcycle is unwilling to start, the cause can be old fuel in the float chamber. The flammable elements of the fuel evaporate after a long time of standing.

If the float chamber is filled with fresh fuel, the engine starts immediately.

Press the starter for a maximum of 5 seconds. Wait for a least 5 seconds until trying again.

Engine has been out of use for more than 1 week

- Empty the carburetor float chamber. ☛ (☛ p. 85)

(EXC-F, EXC-F SIX DAYS, XCF-W, XC-F)

- Turn handle ❶ of the fuel tap to the **ON** position. (Figure 500137-10☛ p. 22)
- ✓ Fuel can flow from the fuel tank to the carburetor.

(SX-F)

- Turn handle ❶ of the fuel tap to the **ON** position. (Figure 500178-10☛ p. 22)
- ✓ Fuel can flow from the fuel tank to the carburetor.

- Remove the motorcycle from the stand.

- Shift gear to neutral.

(250 EXC-F AUS)

- Turn the emergency OFF switch to the position ❶.

The engine is cold

(EXC-F AUS, XCF-W, XC-F, SX-F)

- Pull the choke lever out as far as possible.

(EXC-F EU, EXC-F SIX DAYS)

- Pull the choke lever to the stop.

- Press the electric starter button or press the kickstarter robustly through its full range.

i Info
Don't open the throttle.

Starting up

i Info
If your bike has lights, switch them on before riding. You will then be seen earlier by other motorists. When you are riding, the side stand must be folded up and secured with the rubber band.

- Pull the clutch lever, engage 1st gear, release the clutch lever slowly and simultaneously open the throttle carefully.

Shifting, riding

⚠ Warning
Danger of accidents If you change down at high engine speed, the rear wheel can lock up.

- Do not change into a low gear at high engine speed. The engine races and the rear wheel can block.

i Info
If you hear unusual noises while riding, stop immediately, switch off the engine and contact an authorized KTM workshop. First gear is used for starting off or for steep inclines.

- When conditions allow (incline, road situation, etc.), you can shift into a higher gear. To do so, release the throttle while simultaneously pulling the clutch lever, shift into the next gear, release the clutch and open the throttle.
- If the choke function was activated, deactivate it after the engine has warmed up.
- When you reach maximum speed after fully opening the throttle, turn back the throttle to about $\frac{3}{4}$ of its range; the speed hardly drops, but the fuel consumption falls considerably.
- Always open the throttle only as much as the engine can handle – abrupt throttle opening increases fuel consumption.
- To shift down, brake and close the throttle at the same time.
- Pull the clutch lever and shift into a lower gear, release the clutch lever slowly and open the throttle or shift again.
- Switch off the engine if you expect to be standing for a long time.

Guideline

≥ 2 min

- Avoid frequent and longer slipping of the clutch. This heats the engine oil, the engine and the cooling system.
- Ride with a lower engine speed instead of with a high engine speed and a slipping clutch.

Braking

⚠ Warning
Danger of accidents If you brake too hard, the wheels can lock.

- Adapt your braking to the traffic situation and the road conditions.

⚠ Warning
Danger of accidents Reduced braking caused by spongy pressure point of front or rear brake.

- Have the brake system checked in an authorized KTM workshop, and do not ride any further.

⚠ Warning
Danger of accidents Reduced braking due to wet or dirty brakes.

- Clean or dry dirty or wet brakes by riding and braking gently.

- On sandy, wet or slippery surfaces, use the rear brake.
- Braking should always be completed before you go into a bend. Change down to a lower gear appropriate to your road speed.
- On long downhill stretches, use the braking effect of the engine. Change down one or two gears, but do not overstress the engine. In this way, you have to brake far less and the brakes do not overheat.

Stopping, parking



Warning

Risk of misappropriation Usage by unauthorized persons.

- Never leave the vehicle while the engine is running. Secure the vehicle against use by unauthorized persons.



Warning

Danger of burns Some vehicle components get very hot when the machine is driven.

- Do not touch hot components such as exhaust system, radiator, engine, shock absorber and brakes. Allow these components to cool down before starting work on them.

Note

Danger of damage Danger of damage by the vehicle running away or falling over.

- Always place the vehicle on a firm and even surface.

Note

Fire hazard Some components (engine, radiator and exhaust system) get very hot when the engine is running.

- Do not place the vehicle where there are flammable or explosive substances.

Note

Material damage Damage and destruction of components by excessive load.

- The side stand is designed for the weight of the motorcycle only. Do not sit on the motorcycle when it is supported by the side stand only. The side stand and/or the frame could be damaged and the motorcycle could fall over.

- Brake the motorcycle.
- Shift gear to neutral.

(XCF-W, XC-F, SX-F)

- Press and hold the short circuit button  while the engine is idling until the engine stops.



(EXC-F, EXC-F SIX DAYS)

- Press and hold the short circuit button  while the engine is idling until the engine stops.

(EXC-F, EXC-F SIX DAYS, XCF-W, XC-F)

- Turn handle  of the fuel tap to the **OFF** position. (Figure 500137-10  p. 22)

(SX-F)

- Turn handle  of the fuel tap to the **OFF** position. (Figure 500178-10  p. 22)
- Park the motorcycle on firm ground.

Refueling



Danger

Fire hazard Fuel can easily catch fire.

- Never fill up the vehicle near open flames or burning cigarettes, and always switch off the engine first. Be careful that no fuel is spilt, especially on hot vehicle components. Clean up spilt fuel immediately.
- Fuel in the fuel tank expands when warm and can escape if the tank is overfilled. See specifications on filling up with fuel.



Warning

Danger of poisoning Fuel is poisonous and a health hazard.

- Avoid contact between fuel and skin, eyes and clothing. Do not inhale fuel vapors. If fuel gets into your eyes, rinse immediately with water and contact a doctor. Wash affected skin areas immediately with soap and water. If fuel is swallowed, contact a doctor immediately. Change clothing that has come into contact with fuel.



Warning

Environmental hazard Improper handling of fuel is a danger to the environment.

- Do not allow fuel to get into the ground water, the ground, or the sewage system.

- Switch off the engine.
- Open the filler cap. ( p. 22)

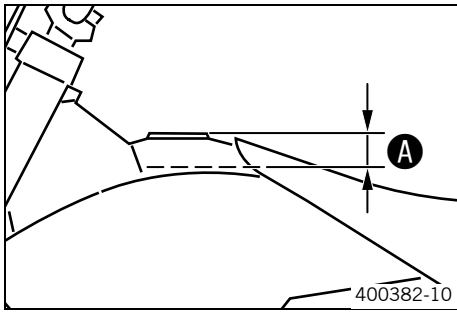

- Fill the fuel tank with fuel up to measurement **A**.

Guideline

Measurement of A	35 mm (1.38 in)	
Total fuel tank capacity, approx. (EXC-F, EXC-F SIX DAYS, XCF-W, XC-F)	9.2 l (2.43 US gal)	Super unleaded (ROZ 95 / RON 95 / PON 91) (☛ p. 116)
Total fuel tank capacity, approx. (SX-F)	8.0 l (2.11 US gal)	Super unleaded (ROZ 95 / RON 95 / PON 91) (☛ p. 116)

- Close the filler cap. (☛ p. 23)

Important maintenance work to be carried out by an authorized KTM workshop.

		S3N	S20A	S30A
Engine	Change the engine oil and oil filter, clean the oil screen. 🛠️ (📖 p. 86)	•	•	
	Replace the spark plug.			•
	Check the valve clearance. 🛠️	•	•	
	Check the engine mounting screws for tightness.	•	•	
	Clean the spark plug connectors and check for tightness.	•	•	
	Check that the screws in the shift lever and the kickstarter are tight.	•	•	
Carburetor	Check the carburetor connection boots for cracks and leakage.		•	
	Check the vent hoses for damage and routing without sharp bends.	•	•	
	Check the idle.	•	•	
Attachments	Check the cooling system for leakage.	•	•	
	Check the antifreeze and coolant level. (📖 p. 80)	•	•	
	Check the exhaust system for leakage and looseness.		•	
	Check the Bowden cables for damage, smooth operation and routing without sharp bends.	•	•	
	Check the fluid level of the hydraulic clutch. (📖 p. 62)	•	•	
	Clean the air filter. 🛠️ (📖 p. 83)	•	•	
	Check the cables for damage and routing without sharp bends.		•	
	Check the functioning of the electrical equipment.	•	•	
	Check the headlamp setting.		•	
Brakes	Check the front brake linings. (📖 p. 66)	•	•	
	Check the rear brake linings. (📖 p. 70)	•	•	
	Check the brake discs. (📖 p. 64)	•	•	
	Check the front brake fluid level. (📖 p. 65)	•	•	
	Check the rear brake fluid level. (📖 p. 69)	•	•	
	Check the brake lines for damage and leakage.	•	•	
	Check the free travel of the hand brake lever. (📖 p. 64)	•	•	
	Check the free travel of the foot brake lever. (📖 p. 68)	•	•	
	Check the brake system function.	•	•	
	Check the screws and guide bolts of the rake system for tightness.	•	•	
Chassis	Check the shock absorber and fork for leakage and functioning. 🛠️	•	•	
	Clean dust boots of fork legs. (📖 p. 46)		•	
	Bleed fork legs. (📖 p. 45)		•	
	Check the swingarm bearing.		•	
	Check play of steering head bearing. (📖 p. 46)	•	•	
	Check all screws to see if they are tight.	•	•	
Wheels	Check the spoke tension. (📖 p. 75)	•	•	
	Check the rim run-out.	•	•	
	Check the tire condition. (📖 p. 74)	•	•	
	Check the tire air pressure. (📖 p. 75)	•	•	
	Check the chain wear. (📖 p. 59)	•	•	
	Check the chain tension. (📖 p. 58)	•	•	
	Clean the chain. (📖 p. 57)	•	•	
	Check the wheel bearing for play.	•	•	
Clean and grease the adjusting screws of the chain adjuster.	•	•		

S3N: After 3 service hours

S20A: Every 20 service hours

S30A: Every 30 service hours

Important maintenance work to be carried out by an authorized KTM workshop (as additional order).

	Competition use				Hobby use			J1A	J2A
	S10A	S20A	S40A	S80A	S20A	S40A	S80A		
Carry out a complete fork service. 🛠️								•	•
Carry out a complete shock absorber service. 🛠️									•
Grease the steering head bearing. 🛠️ (📄 p. 53)								•	•
Treat electric contacts with contact spray.								•	•
Change the hydraulic clutch fluid. 🛠️ (📄 p. 63)								•	•
Change the front brake fluid. 🛠️								•	•
Change the rear brake fluid. 🛠️								•	•
Clean the spark arrestor. 🛠️ (250 XCF-W USA)								•	•
Check the clutch discs for wear. 🛠️		•	•	•		•	•		
Check the clutch. 🛠️		•	•	•		•	•		
Check the cylinder and piston for wear. 🛠️			•	•			•		
Check the camshafts. 🛠️			•	•			•		
Check the valve spring seat. 🛠️			•	•			•		
Check the valves. 🛠️			•	•			•		
Change the valves. 🛠️				•			•		
Check wear of valve guides. 🛠️				•			•		
Change the valve springs. 🛠️			•	•			•		
Check the timing-chain tensioner function. 🛠️			•	•			•		
Check the crankshaft run-out at the bearing pin. 🛠️			•	•			•		
Change the conrod bearing. 🛠️			•	•			•		
Change the crankshaft main bearing. 🛠️				•			•		
Fully check the transmission. 🛠️			•	•			•		
Check the shift mechanism. 🛠️			•	•			•		
Check the spring length of the oil pressure regulator valve. 🛠️			•	•			•		
Change the glass fiber yarn filling of the main silencer. 🛠️	•	•	•	•	•	•	•		
Change the foot brake cylinder seals. 🛠️		•	•	•		•	•		
Check/adjust the carburetor components. 🛠️			•	•		•	•	•	•

S10A: Every 10 service hours / after every race

S20A: Every 20 service hours

S40A: Every 40 service hours

S80A: Every 80 service hours

J1A: annually

J2A: every 2 years

Important maintenance work to be carried out by an authorized KTM workshop.

		S3N	S10A	S30A
Engine	Change the engine oil and oil filter, clean the oil screen. 🛠️ (📖 p. 86)	•	•	•
	Replace the spark plug.			•
	Check the valve clearance. 🛠️	•	•	•
	Check the engine mounting screws for tightness.	•	•	•
	Clean the spark plug connectors and check for tightness.	•	•	•
	Check that the screws in the shift lever and the kickstarter are tight.	•	•	•
Carburetor	Check the carburetor connection boots for cracks and leakage.		•	•
	Check the vent hoses for damage and routing without sharp bends.	•	•	•
	Check the idle.	•	•	•
Attachments	Check the cooling system for leakage.	•	•	•
	Check the antifreeze and coolant level. (📖 p. 80)	•	•	•
	Check the exhaust system for leakage and looseness.		•	•
	Check the Bowden cables for damage, smooth operation and routing without sharp bends.	•	•	•
	Check the fluid level of the hydraulic clutch. (📖 p. 62)	•	•	•
	Clean the air filter. 🛠️ (📖 p. 83)	•	•	•
	Check the cables for damage and routing without sharp bends.		•	•
Brakes	Check the front brake linings. (📖 p. 66)	•	•	•
	Check the rear brake linings. (📖 p. 70)	•	•	•
	Check the brake discs. (📖 p. 64)	•	•	•
	Check the front brake fluid level. (📖 p. 65)	•	•	•
	Check the rear brake fluid level. (📖 p. 69)	•	•	•
	Check the brake lines for damage and leakage.	•	•	•
	Check the free travel of the hand brake lever. (📖 p. 64)	•	•	•
	Check the free travel of the foot brake lever. (📖 p. 68)	•	•	•
	Check the brake system function.	•	•	•
	Check the screws and guide bolts of the brake system for tightness.	•	•	•
Chassis	Check the shock absorber and fork for leakage and functioning. 🛠️	•	•	•
	Clean dust boots of fork legs. (📖 p. 46)		•	•
	Bleed fork legs. (📖 p. 45)		•	•
	Check the swingarm bearing.		•	•
	Check play of steering head bearing. (📖 p. 46)	•	•	•
	Check all screws to see if they are tight.	•	•	•
Wheels	Check the spoke tension. (📖 p. 75)	•	•	•
	Check the rim run-out.	•	•	•
	Check the tire condition. (📖 p. 74)	•	•	•
	Check the tire air pressure. (📖 p. 75)	•	•	•
	Check the chain wear. (📖 p. 59)	•	•	•
	Check the chain tension. (📖 p. 58)	•	•	•
	Clean the chain. (📖 p. 57)	•	•	•
	Check the wheel bearing for play.	•	•	•
Clean and grease the adjusting screws of the chain adjuster.	•	•	•	

S3N: After 3 service hours - corresponds to about 21 liters (5.55 US gal) of fuel

S10A: Every 10 service hours - corresponds to about 70 liters (18.5 US gal) of fuel / after every race

S30A: Every 30 service hours - corresponds to about 210 liters (55.5 US gal) of fuel

Important maintenance work to be carried out by an authorized KTM workshop (as additional order).

	S10A	S20A	S40A	S80A	J1A	J2A
Carry out a complete fork service. 🛠️					•	•
Carry out a complete shock absorber service. 🛠️						•
Grease the steering head bearing. 🛠️ (📖 p. 53)					•	•
Treat electric contacts with contact spray.					•	•
Change the hydraulic clutch fluid. 🛠️ (📖 p. 63)					•	•
Change the front brake fluid. 🛠️					•	•
Change the rear brake fluid. 🛠️					•	•
Check the clutch discs for wear. 🛠️		•	•	•		
Check the clutch. 🛠️		•	•	•		
Check the cylinder and piston for wear. 🛠️			•	•		
Check the camshafts. 🛠️			•	•		
Check the valve spring seat. 🛠️			•	•		
Check the valves. 🛠️			•	•		
Change the valves. 🛠️				•		
Check wear of valve guides.				•		
Change the valve springs. 🛠️			•	•		
Check the timing-chain tensioner function. 🛠️			•	•		
Check the crankshaft run-out at the bearing pin. 🛠️			•	•		
Change the conrod bearing. 🛠️			•	•		
Change the crankshaft main bearing. 🛠️				•		
Fully check the transmission. 🛠️			•	•		
Check the shift mechanism. 🛠️			•	•		
Check the spring length of the oil pressure regulator valve. 🛠️			•	•		
Change the glass fiber yarn filling of the main silencer. 🛠️	•	•	•	•		
Change the foot brake cylinder seals. 🛠️		•	•	•		
Check/adjust the carburetor components. 🛠️			•	•	•	•

S10A: Every 10 service hours - corresponds to about 70 liters (18.5 US gal) of fuel / after every race

S20A: Every 20 service hours - corresponds to about 140 liters (37 US gal) of fuel

S40A: Every 40 service hours - corresponds to about 280 liters (74 US gal) of fuel

S80A: Every 80 service hours - corresponds to about 560 liters (148 US gal) of fuel

J1A: annually

J2A: every 2 years

Important checks and maintenance work to be carried out by the rider.

	NB1A
Check the engine oil level. (☛ p. 86)	•
Check the front brake fluid level. (☛ p. 65)	•
Check the rear brake fluid level. (☛ p. 69)	•
Check the front brake linings. (☛ p. 66)	•
Check the rear brake linings. (☛ p. 70)	•
Check and adjust Bowden cables.	•
Bleed fork legs. (☛ p. 45)	•
Clean dust boots of fork legs. (☛ p. 46)	•
Clean the chain. (☛ p. 57)	•
Check the chain tension. (☛ p. 58)	•
Check the chain wear. (☛ p. 59)	•
Check the rear sprocket / engine sprocket for wear. (☛ p. 59)	•
Clean the air filter. 🗑️ (☛ p. 83)	•
Check the tire air pressure. (☛ p. 75)	•
Check the tire condition. (☛ p. 74)	•
Check the coolant level. (☛ p. 80)	•
Empty the carburetor float chamber. 🗑️ (☛ p. 85)	•
Check that all operating elements for smooth operation.	•
Check braking.	•
Check all screws, nuts and hose clamps regularly for tightness.	•

NB1A: Depending on conditions of use according to requirements.

Jacking up the motorcycle

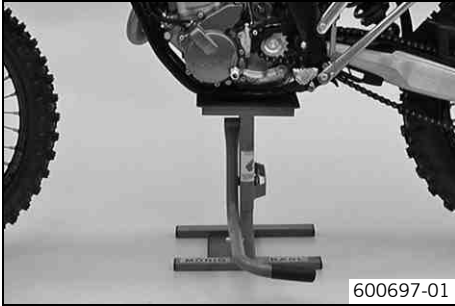

Note

Danger of damage Danger of damage by the vehicle running away or falling over.

- Always place the vehicle on a firm and even surface.

- Jack up the motorcycle underneath the engine. The wheels must no longer touch the ground.

Work stand (54829055000)

- Secure the motorcycle against falling over.

Removing the motorcycle from the work stand

Note

Danger of damage Danger of damage by the vehicle running away or falling over.

- Always place the vehicle on a firm and even surface.

- Remove the motorcycle from the work stand.

- Remove the work stand.

Checking the basic chassis setting with the rider's weight



Info

When adjusting the basic chassis setting, first adjust the shock absorber and then the fork.

- For optimal motorcycle riding characteristics and to avoid damage to forks, shock absorbers, swing arm and frame, the basic settings of the suspension components must match your body weight.
- As delivered, KTM offroad motorcycles are adjusted for a standard rider weight (with full protective clothing).

Guideline

Standard rider weight	75... 85 kg (165... 187 lb.)
-----------------------	------------------------------

- If your weight is above or below the standard range, you have to adjust the basic setting of the suspension components accordingly.
- Small weight differences can be compensated by adjusting the spring preload, but in the case of large weight differences, the springs must be replaced.

Compression damping of shock absorber

The shock absorber can regulate compression damping separately in the low-speed and high-speed ranges (Dual Compression Control). The term low and high speed refers to the movement of the shock absorber during compression and not the riding speed of the motorcycle.

The low-speed and high-speed technology works non-specifically.

Adjusting high-speed compression damping of the shock absorber



Danger

Danger of accidents The shock absorber is under high pressure.

- The shock absorber is filled with highly compressed nitrogen, so never dismantle the shock absorber or carry out any maintenance on it yourself.



Info

The high-speed setting can be seen during the fast compression of the shock absorber.

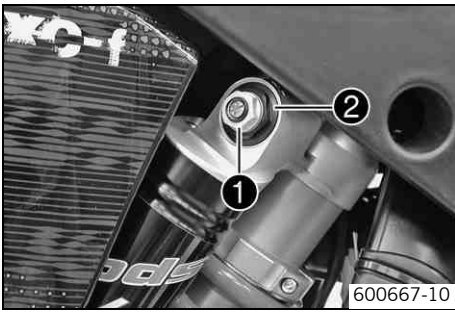

- Turn adjusting screw ❶ clockwise with a ring wrench until it stops.

i Info
Do not loosen nut ❷!

- Turn back counterclockwise by the number of turns corresponding to the shock absorber type.

Guideline

Compression damping, high-speed (EXC-F, EXC-F SIX DAYS, XCF-W)	
Comfort	2 turns
Standard	1.5 turns
Sport	1 turn
Compression damping, high-speed (250 XC-F USA)	
Comfort	1 turn
Standard	1 turn
Sport	3/4 turn
Compression damping, high-speed (250 SX-F EU)	
Comfort	1.5 turns
Standard	1.5 turns
Sport	1 turn
Compression damping, high-speed (250 SX-F USA)	
Comfort	1 turn
Standard	1 turn
Sport	3/4 turn

i Info
Turn clockwise to increase damping, turn counterclockwise to reduce suspension damping.

Adjusting the low-speed compression damping of the shock absorber

! Danger
Danger of accidents The shock absorber is under high pressure.

- The shock absorber is filled with highly compressed nitrogen, so never dismantle the shock absorber or carry out any maintenance on it yourself.

i Info
The low-speed setting can be seen during the slow to normal compression of the shock absorber.

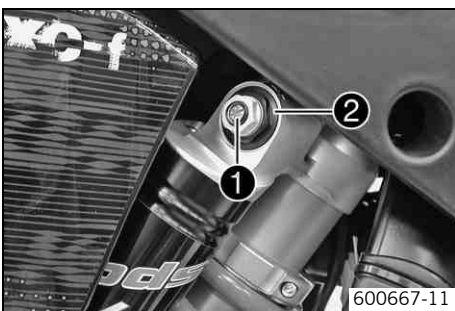

- Turn adjusting screw ❶ clockwise with a screwdriver until it stops.

i Info
Do not loosen nut ❷!

- Turn back counterclockwise by the number of clicks corresponding to the shock absorber type.

Guideline

Compression damping, low-speed (EXC-F, EXC-F SIX DAYS, XCF-W)	
Comfort	18 clicks
Standard	15 clicks
Sport	12 clicks
Compression damping, low-speed (250 XC-F USA)	
Comfort	17 clicks
Standard	15 clicks
Sport	13 clicks
Compression damping, low-speed (250 SX-F EU)	
Comfort	17 clicks
Standard	15 clicks
Sport	13 clicks
Compression damping, low-speed (250 SX-F USA)	
Comfort	17 clicks
Standard	15 clicks
Sport	13 clicks

i Info
Turn clockwise to increase damping, turn counterclockwise to reduce suspension damping.

Adjusting the rebound damping of the shock absorber

! Danger
Danger of accidents The shock absorber is under high pressure.

- The shock absorber is filled with highly compressed nitrogen, so never dismantle the shock absorber or carry out any maintenance on it yourself.

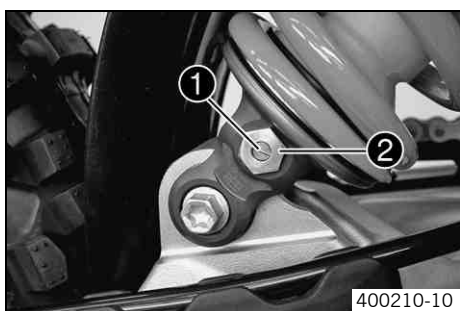

- Turn adjusting screw ❶ clockwise until it stops.

i Info
Do not loosen nut ❷!

- Turn back counterclockwise by the number of clicks corresponding to the shock absorber type.

Guideline

Rebound damping (EXC-F, EXC-F SIX DAYS, XCF-W)	
Comfort	26 clicks
Standard	24 clicks
Sport	22 clicks
Rebound damping (250 XC-F USA)	
Comfort	25 clicks
Standard	25 clicks
Sport	23 clicks
Rebound damping (250 SX-F EU)	
Comfort	24 clicks
Standard	22 clicks
Sport	21 clicks
Rebound damping (250 SX-F USA)	
Comfort	25 clicks
Standard	24 clicks
Sport	22 clicks

i Info
Turn clockwise to increase damping, turn counterclockwise to reduce suspension damping.

Measuring rear wheel sag unloaded

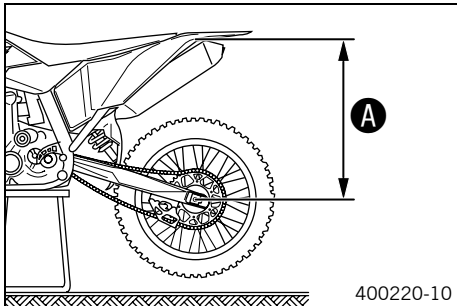

- Jack up the motorcycle. (☛ p. 37)
- Measure the distance – as vertical as possible – between the rear axle and a fixed point, for example, a mark on the side cover.
- Make a note of the value as measurement **A**.
- Remove the motorcycle from the work stand. (☛ p. 37)

Checking the static sag of the shock absorber

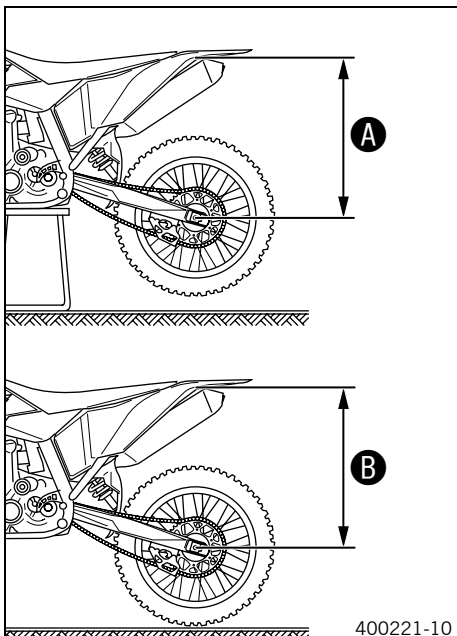

- Measure distance **A** of rear wheel unloaded. (☛ p. 40)
- Ask someone to help you by holding the motorcycle upright.
- Measure the distance between the rear axle and the fixed point again.
- Make a note of the value as measurement **B**.

i Info
The static sag is the difference between measurements **A** and **B**.

- Check the static sag.

Static sag (EXC-F, EXC-F SIX DAYS, XCF-W)	35 mm (1.38 in)
Static sag (250 XC-F USA)	33 mm (1.3 in)
Static sag (250 SX-F EU)	33 mm (1.3 in)
Static sag (250 SX-F USA)	33 mm (1.3 in)

- » If the static sag is less or more than the specified value:
 - Adjust the spring preload of the shock absorber. ☛ (☛ p. 41)

Checking the riding sag of the shock absorber

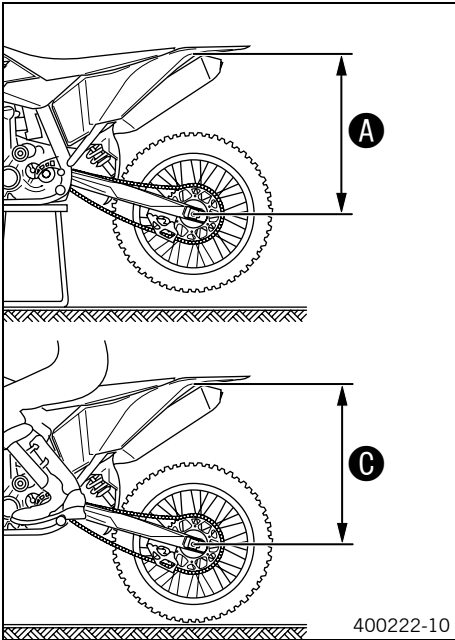

- Measure distance **A** of rear wheel unloaded. (☞ p. 40)
- With another person holding the motorcycle, sit on the saddle with full protective clothing in a normal sitting position (feet on footrests) and bounce up and down a few times until the rear suspension levels out.
- The other person now has to measure the distance between the rear axle and a fixed point.
- Make a note of the value as measurement **C**.

i Info

The riding sag is the difference between measurements **A** and **C**.

- Check the riding sag.

Riding sag (EXC-F, EXC-F SIX DAYS, XCF-W)	105 mm (4.13 in)
Riding sag (250 XC-F USA)	112 mm (4.41 in)
Riding sag (250 SX-F EU)	105 mm (4.13 in)
Riding sag (250 SX-F USA)	107 mm (4.21 in)

» If the riding sag differs from the specified measurement:

- Adjust the riding sag. ☞ (☞ p. 42)

Adjusting the spring preload of the shock absorber ☞

! Danger

Danger of accidents The shock absorber is under high pressure.

- The shock absorber is filled with highly compressed nitrogen, so never dismantle the shock absorber or carry out any maintenance on it yourself.

i Info

Before changing the spring preload, make a note of the present setting, e.g., by measuring the length of the spring.

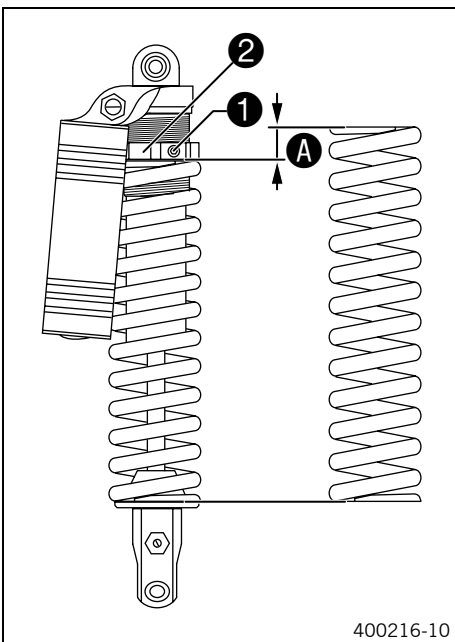

- Remove shock absorber. ☞ (☞ p. 42)
- After removing the shock absorber, clean it thoroughly.
- Loosen screw **1**.
- Turn adjusting ring **2** until the spring is no longer under tension.

Combination wrench (50329080000)
Hook wrench (T106S)

- Measure the overall spring length when not under tension.
- Tighten the spring by turning adjusting ring **2** to measurement **A**.

Guideline

Spring preload (EXC-F, EXC-F SIX DAYS, XCF-W)	9 mm (0.35 in)
Spring preload (250 XC-F USA)	5 mm (0.2 in)
Spring preload (250 SX-F EU)	6 mm (0.24 in)
Spring preload (250 SX-F USA)	7 mm (0.28 in)

i Info

Depending on the static sag and/or the riding sag, it may be necessary to increase or decrease the spring preload.

- Tighten screw **1**.

Guideline

Screw, shock absorber adjusting ring	M6	5 Nm (3.7 lbf ft)
--------------------------------------	----	-------------------

- Install the shock absorber. ☞ (☞ p. 42)

Adjusting the riding sag 🛠️

- Remove shock absorber. 🛠️ (🔧 p. 42)
- After removing the shock absorber, clean it thoroughly.
- Choose and mount a suitable spring.

Guideline

Spring rate	
Weight of rider: 65... 75 kg (143... 165 lb.)	66 N/mm (377 lb/in)
Weight of rider: 75... 85 kg (165... 187 lb.)	69 N/mm (394 lb/in)
Weight of rider: 85... 95 kg (187... 209 lb.)	72 N/mm (411 lb/in)

i Info

The spring rate is shown on the outside of the spring.
Smaller weight differences can be compensated by changing the spring preload.

- Install the shock absorber. 🛠️ (🔧 p. 42)
- Check the static sag of the shock absorber. (🔧 p. 40)
- Check the riding sag of the shock absorber. (🔧 p. 41)
- Adjust the rebound damping of the shock absorber. (🔧 p. 39)

Removing the shock absorber 🛠️

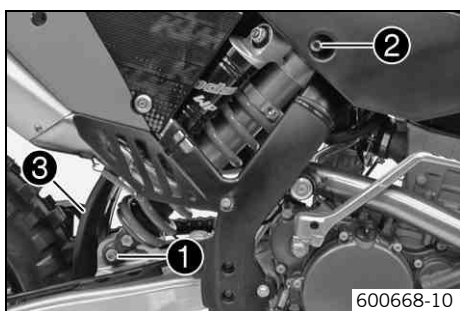

- Jack up the motorcycle. (🔧 p. 37)
- Remove screw 1 and lower the rear wheel with the swing arm as far as possible without blocking the rear wheel. Fix the rear wheel in this position.
- Remove screw 2, push splash protector 3 to the side, and remove the shock absorber.

Installing the shock absorber 🛠️

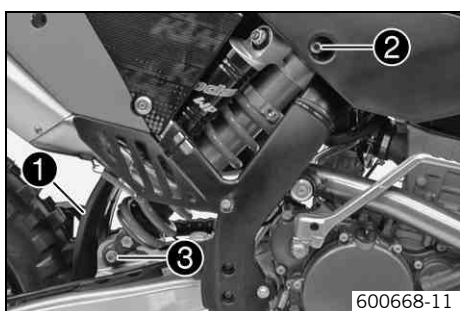

- Push splash protector 1 to the side and position the shock absorber. Mount and tighten screw 2.

Guideline

Screw, top shock absorber	M12	80 Nm (59 lbf ft)	Loctite® 243™
---------------------------	-----	----------------------	----------------------

- Mount and tighten screw 3.

Guideline

Screw, bottom shock absorber	M12	80 Nm (59 lbf ft)	Loctite® 243™
------------------------------	-----	----------------------	----------------------

i Info

The heim joint for the shock absorber at the swing arm is Teflon coated. It must not be greased with grease or with other lubricants. Lubricants dissolve the Teflon coating, thereby drastically reducing the service life.

- Remove the motorcycle from the work stand. (🔧 p. 37)

Checking basic setting of fork

i Info
For various reasons, no exact riding sag can be determined for the forks.

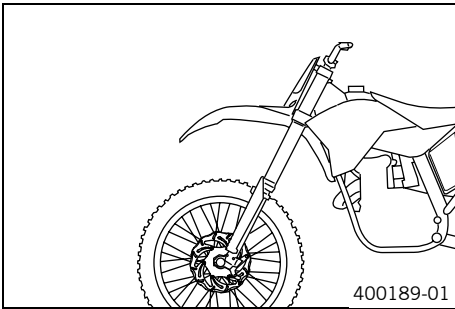

- As with the shock absorber, smaller weight differences can be compensated by the spring preload.
- However, if your fork is often overloaded (hard end stop on compression), you must fit harder springs to avoid damage to the fork and frame.

Adjusting the compression damping of the fork

i Info
The hydraulic compression damping determines the fork suspension behavior.

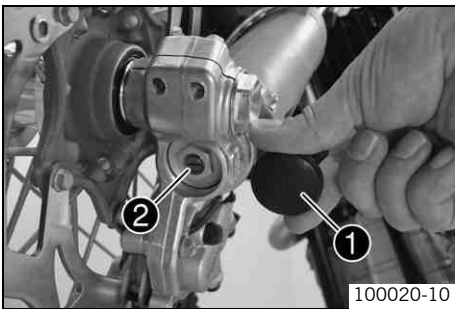

(EXC-F, EXC-F SIX DAYS, XCF-W)

- Remove protection covers **1**.
- Turn adjusting screws **2** clockwise until they stop.

i Info
The adjusting screws **2** are located at the bottom end of the fork legs. Make the same adjustment on both fork legs.

- Turn back counterclockwise by the number of clicks corresponding to the fork type.

Guideline

Compression damping	
Comfort	26 clicks
Standard	22 clicks
Sport	20 clicks

i Info
Turn clockwise to increase damping, turn counterclockwise to reduce suspension damping.

- Mount protection covers **1**.

(SX-F, 250 XC-F USA)

- Turn adjusting screws **1** clockwise until they stop.

i Info
The adjusting screws **1** are located at the top end of the fork legs. Make the same adjustment on both fork legs.

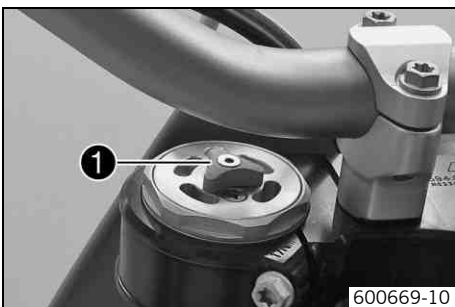

- Turn back counterclockwise by the number of clicks corresponding to the fork type.

Guideline

Compression damping (250 XC-F USA)	
Comfort	17 clicks
Standard	15 clicks
Sport	13 clicks
Compression damping (250 SX-F EU)	
Comfort	14 clicks
Standard	12 clicks
Sport	10 clicks
Compression damping (250 SX-F USA)	
Comfort	17 clicks
Standard	15 clicks
Sport	13 clicks

i Info
Turn clockwise to increase damping, turn counterclockwise to reduce suspension damping.

Adjusting the rebound damping of fork

i Info
The hydraulic rebound damping determines the fork suspension behavior.

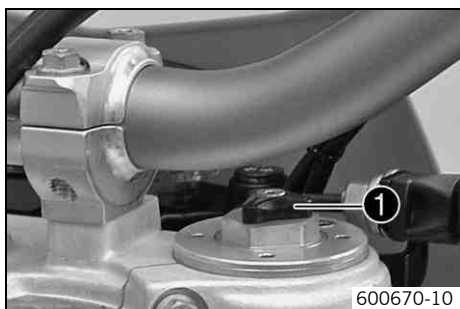

(EXC-F, EXC-F SIX DAYS, XCF-W)

- Turn adjusting screws ❶ clockwise until they stop.

i Info
The adjusting screws ❶ are located at the top end of the fork legs. Make the same adjustment on both fork legs.

- Turn back counterclockwise by the number of clicks corresponding to the fork type.

Guideline

Rebound damping	
Comfort	24 clicks
Standard	22 clicks
Sport	22 clicks

i Info
Turn clockwise to increase damping, turn counterclockwise to reduce suspension damping.

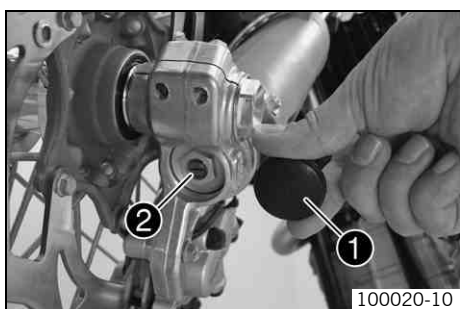

(SX-F, 250 XC-F USA)

- Remove protection covers ❶.
- Turn adjusting screws ❷ clockwise until they stop.

i Info
The adjusting screws ❷ are located at the bottom end of the fork legs. Make the same adjustment on both fork legs.

- Turn back counterclockwise by the number of clicks corresponding to the fork type.

Guideline

Rebound damping (250 XC-F USA)	
Comfort	22 clicks
Standard	21 clicks
Sport	21 clicks
Rebound damping (250 SX-F EU)	
Comfort	21 clicks
Standard	20 clicks
Sport	20 clicks
Rebound damping (250 SX-F USA)	
Comfort	22 clicks
Standard	22 clicks
Sport	20 clicks

i Info
Turn clockwise to increase damping, turn counterclockwise to reduce suspension damping.

- Mount protection covers ❶.

Adjusting the spring preload of the fork (EXC-F, EXC-F SIX DAYS, XCF-W)



- Turn adjusting screws counterclockwise until they stop.

i Info
Make the same adjustment on both fork legs.

- Turn back clockwise by the number of turns corresponding to the fork type.

Guideline

Spring preload - Preload Adjuster	
Comfort	0 turn
Standard	1 turn
Sport	3 turns

i Info
Turn clockwise to increase spring preload, turn counterclockwise to reduce spring preload.
Adjusting the spring preload has no influence on the absorption setting of the rebound damping.
Basically, however, you should set the rebound damping higher with a higher spring preload.

Bleeding fork legs

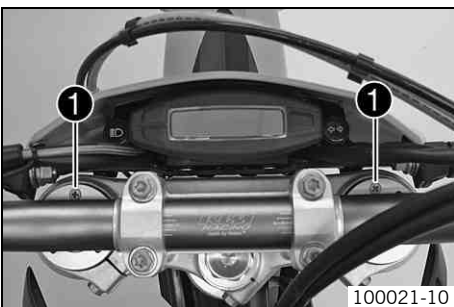

- Jack up the motorcycle. (☛ p. 37)
- Remove bleeder screws ❶ briefly.
✓ Any excess pressure escapes from the interior of the fork.
- Mount and tighten bleeder screws.
- Remove the motorcycle from the work stand. (☛ p. 37)

Cleaning dust boots of fork legs



- Jack up the motorcycle. (☛ p. 37)
- Loosen the fork protection. (☛ p. 46)
- Push dust boots ❶ of both fork legs downwards.



Info

The dust boots should remove dust and coarse dirt particles from the fork tubes. Over time, dirt can penetrate behind the dust boots. If this dirt is not removed, the oil seals behind can start to leak.



Warning

Danger of accidents Reduced braking due to oil or grease on the brake discs.

- Always keep the brake discs free of oil and grease, and clean them with brake cleaner when necessary.

- Clean and oil the dust boots and inner fork tube of both fork legs.

Universal oil spray (☛ p. 118)

- Press the dust boots back into their normal position.
- Remove excess oil.
- Position the fork protection. (☛ p. 46)
- Remove the motorcycle from the work stand. (☛ p. 37)

Loosening the fork protection

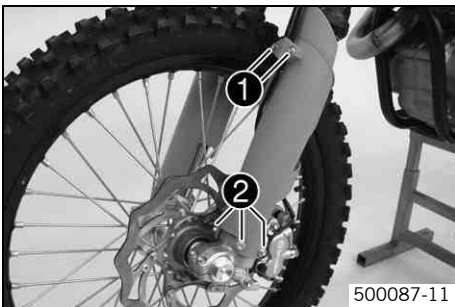

- Remove screws ❶ and take off clamp.
- Remove screws ❷ on left fork leg. Push the fork protection downwards.
- Remove the screws on the right fork leg. Push the fork protection downwards.

Positioning the fork protection



- Position the fork protection on the left fork leg. Mount and tighten screws ❶.

Guideline

Remaining screws, chassis	M6	10 Nm (7.4 lbf ft)
---------------------------	----	--------------------

(EXC-F, EXC-F SIX DAYS, XCF-W)

- Position the wiring harness.
- Position the brake line. Put the clamp on, mount and tighten screws ❷.
- Position the fork protection on the right fork leg. Mount and tighten the screws.

Guideline

Remaining screws, chassis	M6	10 Nm (7.4 lbf ft)
---------------------------	----	--------------------

Checking play of steering head bearing



Warning

Danger of accidents Unsafe riding behavior due to incorrect steering head bearing play.

- The steering head bearing play should be adjusted immediately in an authorized KTM workshop.



Info

If the bike is driven for a longer time with play in the steering head bearing, the bearing and the bearing seats in the frame can be damaged after time.

- Jack up the motorcycle. (☛ p. 37)

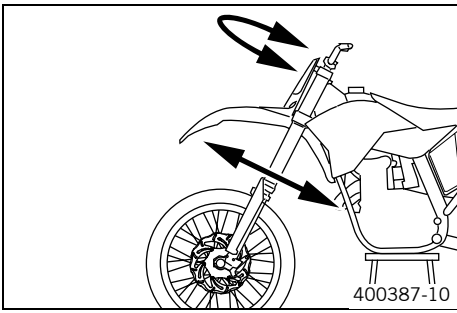

- Move the handlebar to the straight-ahead position. Move the fork legs to and fro in the direction of travel.

No play should be noticeable in the steering head bearing.

- » If there is noticeable play present:
 - (EXC-F SIX DAYS, XCF-W USA, XC-F, SX-F)**
 - Adjust play of the steering head bearing. (🔧 p. 47)
 - (EXC-F EU, EXC-F AUS, XCF-W ZA)**
 - Adjust play of the steering head bearing. (🔧 p. 47)
- Move the handlebar to and fro over the entire steering range.

The handlebar must be able to move easily over the entire steering range. No resting locations should be noticeable.

- » If click positions are noticeable:
 - (EXC-F SIX DAYS, XCF-W USA, XC-F, SX-F)**
 - Adjust play of the steering head bearing. (🔧 p. 47)
 - (EXC-F EU, EXC-F AUS, XCF-W ZA)**
 - Adjust play of the steering head bearing. (🔧 p. 47)
 - Check the steering head bearing and replace if required.
- Remove the motorcycle from the work stand. (🔧 p. 37)

Adjusting play of steering head bearing (EXC-F EU, EXC-F AUS, XCF-W ZA)

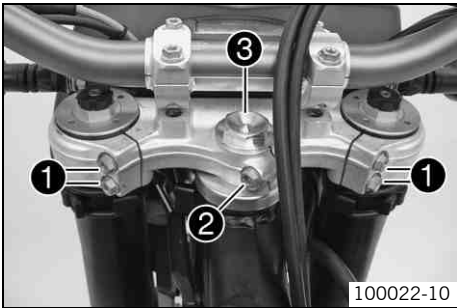

- Jack up the motorcycle. (🔧 p. 37)
- Loosen screws ❶ and ❷.
- Loosen and retighten screw ❸.

Guideline

Screw, top steering head	M20x1.5	10 Nm (7.4 lbf ft)
--------------------------	---------	--------------------

- Using a plastic hammer, tap lightly on the upper triple clamp to avoid strains.
- Fully tighten screw ❶.

Guideline

Screw, top triple clamp	M8	20 Nm (14.8 lbf ft)
-------------------------	----	---------------------

- Tighten screw ❷.

Guideline

Screw, top steering stem	M8	20 Nm (14.8 lbf ft)
--------------------------	----	---------------------

- Check play of steering head bearing. (🔧 p. 46)

Adjusting play of steering head bearing (EXC-F SIX DAYS, XCF-W USA, XC-F, SX-F)

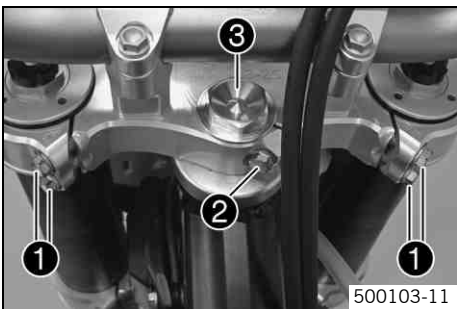

- Jack up the motorcycle. (🔧 p. 37)
- Loosen screw ❶. Remove screw ❷.
- Loosen and retighten screw ❸.

Guideline

Screw, top steering head	M20x1.5	10 Nm (7.4 lbf ft)
--------------------------	---------	--------------------

- Using a plastic hammer, tap lightly on the upper triple clamp to avoid strains.
- Fully tighten screw ❶.

Guideline

Screw, top triple clamp	M8	17 Nm (12.5 lbf ft)
-------------------------	----	---------------------

- Mount and tighten screw ❷.

Guideline

Screw, top steering stem	M8	17 Nm (12.5 lbf ft)	Loctite® 243™
--------------------------	----	---------------------	----------------------

- Check play of steering head bearing. (🔧 p. 46)

Fork offset (XCF-W USA, XC-F, SX-F)

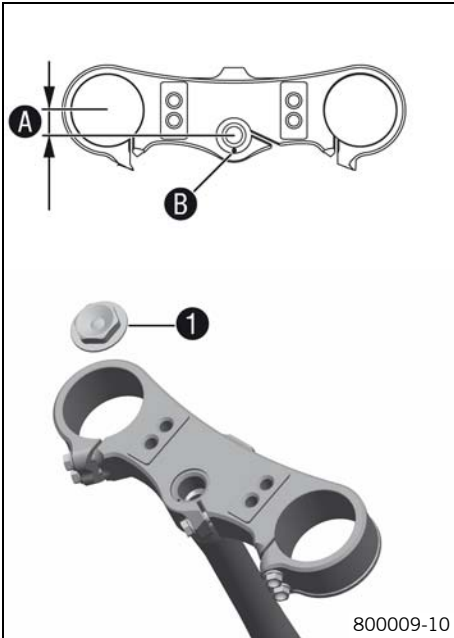

You can see the currently set offset if you remove screw ❶.

The fork offset ❶ has an impact on the handling of the vehicle. It is calculated from the center of the fork leg to the center of the steering head bearing.

The fork offset can optionally be adjusted.

Marking ❷ to the front gives greater stability on fast racetracks.

Fork offset	
Front marking	18 mm (0.71 in)

Marking ❷ to the rear (condition at delivery) gives better handling in bends.

Fork offset	
Rear marking	20 mm (0.79 in)

Setting the fork offset ↻ (XCF-W USA, XC-F, SX-F)

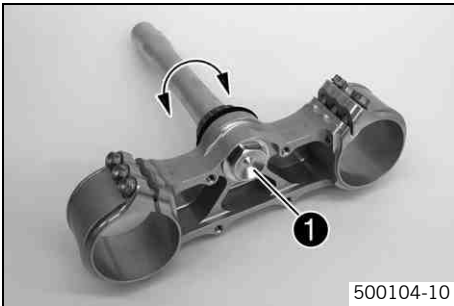

- Remove the lower triple clamp. ↻ (☞ p. 50)
- Remove screw ❶. Remove the steering stem.
- Clean the parts and check for damage.
- Rotate the steering stem 180° and insert into the triple clamp. Mount and tighten screw ❶.

Guideline

Screw, bottom steering head	M20x1.5	60 Nm (44.3 lbf ft)	Loctite® 243™
-----------------------------	---------	---------------------	---------------

- Install the lower triple clamp. ↻ (☞ p. 51)

Removing the fork legs

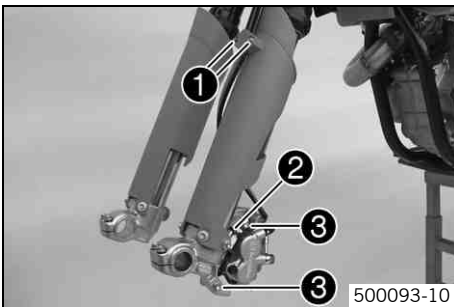

- Remove the front wheel. ↻ (☞ p. 72)
- Remove screws ❶ and take off clamp.

(EXC-F, EXC-F SIX DAYS, XCF-W)

- Remove cable clip ❷.
- Remove screws ❸ and take off brake caliper.
- Hang the brake caliper and the brake line loosely to the side.

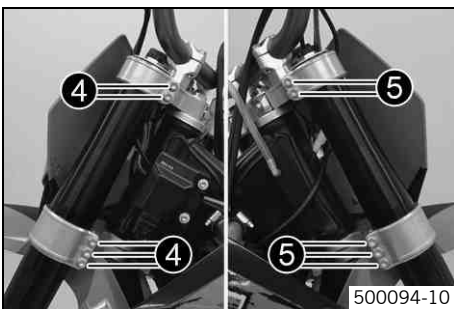

(EXC-F SIX DAYS, XCF-W USA, XC-F, SX-F)

- Loosen screw ❹. Remove the fork leg on the left.
- Loosen screw ❺. Remove the fork leg on the right.

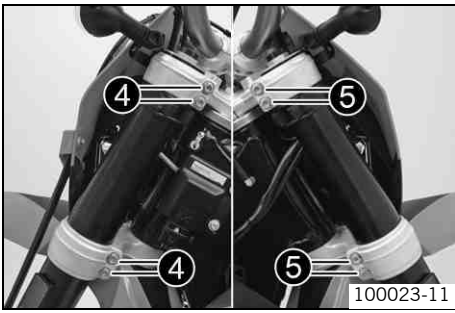

(EXC-F EU, EXC-F AUS, XCF-W ZA)

- Loosen screw ④. Remove the fork leg on the left.
- Loosen screw ⑤. Remove the fork leg on the right.

Installing the fork legs ↶

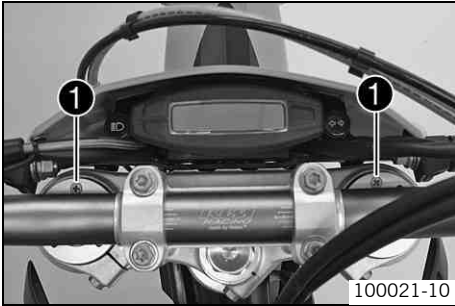

- Position the fork legs.

i Info

The topmost sunk nut in the fork leg must be flush to the upper edge of the upper triple clamp. Position the bleeder screw ① to the front.

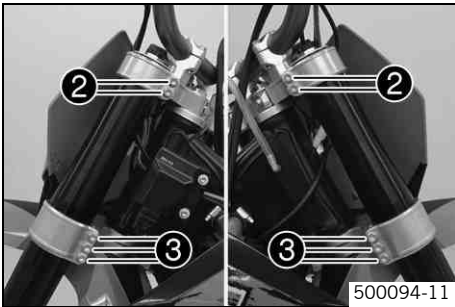

(EXC-F SIX DAYS, XCF-W USA, XC-F, SX-F)

- Fully tighten screw ②.

Guideline

Screw, top triple clamp	M8	17 Nm (12.5 lbf ft)
-------------------------	----	------------------------

- Fully tighten screw ③.

Guideline

Screw, bottom triple clamp	M8	12 Nm (8.9 lbf ft)
----------------------------	----	-----------------------

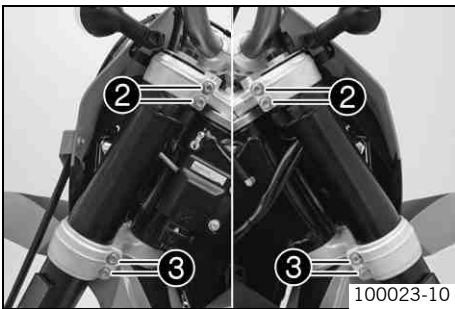

(EXC-F EU, EXC-F AUS, XCF-W ZA)

- Fully tighten screw ②.

Guideline

Screw, top triple clamp	M8	20 Nm (14.8 lbf ft)
-------------------------	----	------------------------

- Fully tighten screw ③.

Guideline

Screw, bottom triple clamp	M8	15 Nm (11.1 lbf ft)
----------------------------	----	------------------------

- Position brake caliper, mount and tighten screws ④.

Guideline

Screw, front brake caliper	M8	25 Nm (18.4 lbf ft)	Loctite® 243™
----------------------------	----	------------------------	----------------------

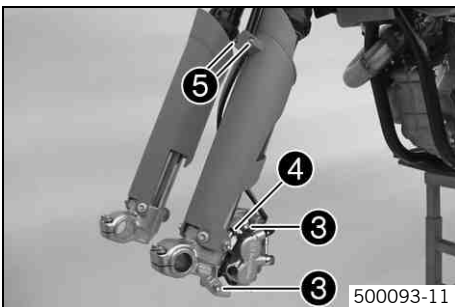

(EXC-F, EXC-F SIX DAYS, XCF-W)

- Mount cable clip ④.
- Position the wiring harness.
- Position the brake line. Put the clamp on, mount and tighten screws ⑤.
- Install the front wheel. ↶ (↷ p. 72)

Removing the fork protector ↩

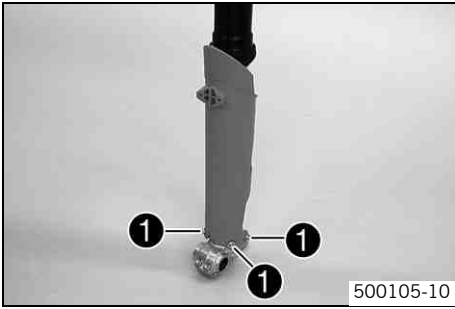

- Remove the fork legs. (↩ p. 48)
- Remove screws ❶ on the left fork leg. Remove the fork protector upwards.
- Remove the screws on the right fork leg. Remove the fork protector upwards.

Installing the fork protector ↩

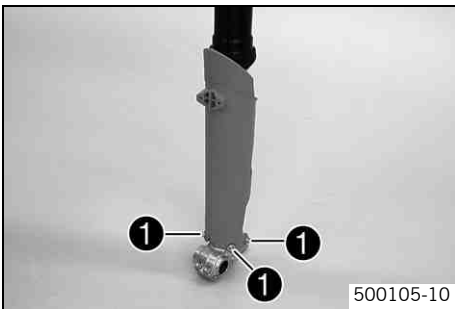

- Position the fork protection on the left fork leg. Mount and tighten screws ❶.

Guideline

Remaining screws, chassis	M6	10 Nm (7.4 lbf ft)
---------------------------	----	--------------------

- Position the fork protection on the right fork leg. Mount and tighten the screws.

Guideline

Remaining screws, chassis	M6	10 Nm (7.4 lbf ft)
---------------------------	----	--------------------

- Install the fork legs. (↩ p. 49)

Removing the lower triple clamp ↩ (EXC-F SIX DAYS, XCF-W USA, XC-F, SX-F)

- Remove the fork legs. (↩ p. 48)

(XCF-W USA, XC-F, SX-F)

- Dismount the start number plate. (↩ p. 54)

(250 EXC-F SIX DAYS EU)

- Remove the headlight mask with the headlight. (↩ p. 53)
- Dismount the front fender. (↩ p. 53)
- Remove screws ❶ and hang the CDI control unit to the side.

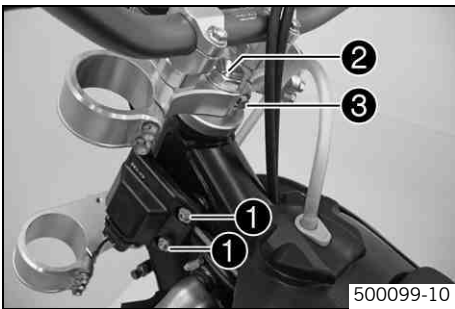

Info

Do not unplug the CDI control unit.

- Remove screw ❷. Remove screw ❸, take off the top triple clamp with the handlebar and place it on one side.



Info

Protect the motorcycle and its attachments from damage by covering them. Do not bend the cables and lines.

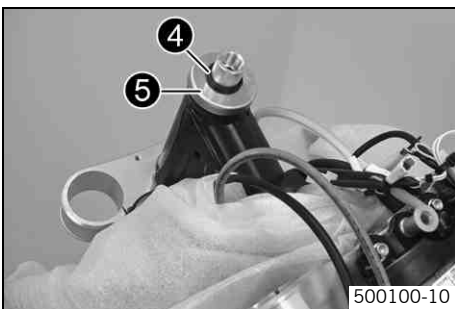

- Remove O-ring ❹. Remove protector ring ❺.
- Remove the lower triple clamp with the steering stem.
- Remove the upper steering head bearing.

Removing the lower triple clamp (EXC-F EU, EXC-F AUS, XCF-W ZA)

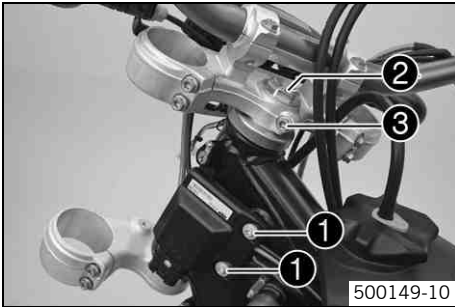

500149-10

- Remove the fork legs. (☛ p. 48)
- Remove the headlight mask with the headlight. (☛ p. 53)
- Dismount the front fender. (☛ p. 53)
- Remove screws ❶ and hang the CDI control unit to the side.

i Info
Do not unplug the CDI control unit.

- Remove screw ❷. Loosen screw ❸. Take off top triple clamp with the handlebar and place it on one side.

i Info
Protect the motorcycle and its attachments from damage by covering them. Do not bend the cables and lines.

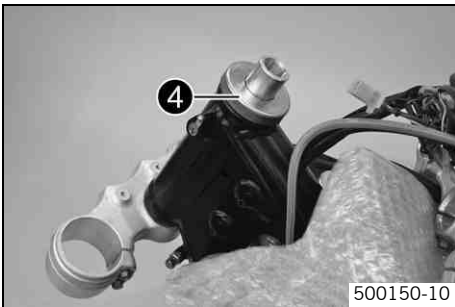

500150-10

- Remove protector ring ❹.
- Remove the lower triple clamp with the steering stem.
- Remove the upper steering head bearing.

Installing the lower triple clamp (EXC-F SIX DAYS, XCF-W USA, XC-F, SX-F)

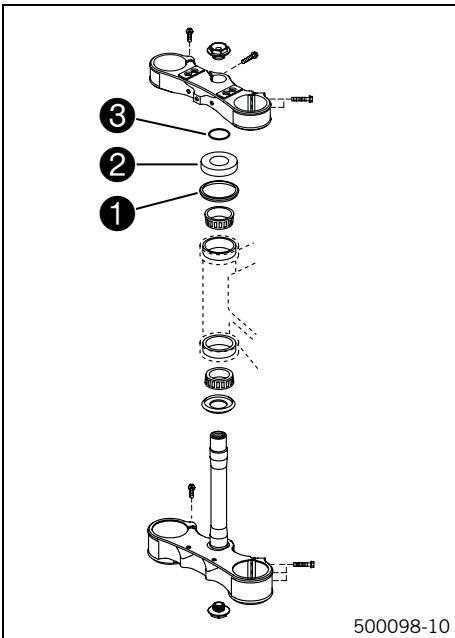

500098-10

- Clean the bearing and sealing elements, check for damage, and grease.

Long-life grease (☛ p. 117)

- Insert the lower triple clamp with the steering stem. Mount the upper steering head bearing.

i Info
Check whether the top steering head seal ❶ is correctly positioned.

- Push up protective ring ❷ and O-ring ❸.

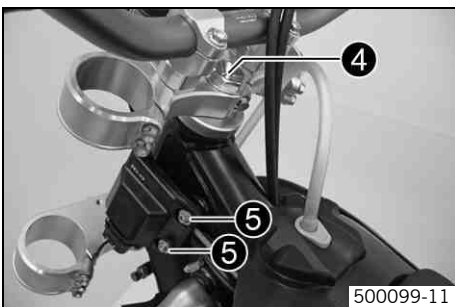

500099-11

- Position the upper triple clamp with the steering.
- Mount and tighten screw ❹.

Guideline

Screw, top steering head	M20x1.5	10 Nm (7.4 lbf ft)
--------------------------	---------	--------------------

- Position the clutch line, wiring harness and CDI control unit. Mount and tighten screws ❺.

Guideline

Remaining screws, chassis	M6	10 Nm (7.4 lbf ft)
---------------------------	----	--------------------

- Install the front fender. (☛ p. 53)

(XCF-W USA, XC-F, SX-F)

- Install the start number plate. (☛ p. 54)

(250 EXC-F SIX DAYS EU)

- Refit the headlight mask with the headlight. (☛ p. 54)
- Install the fork legs. ☛ (☛ p. 49)
- Mount and tighten screw ⑥.

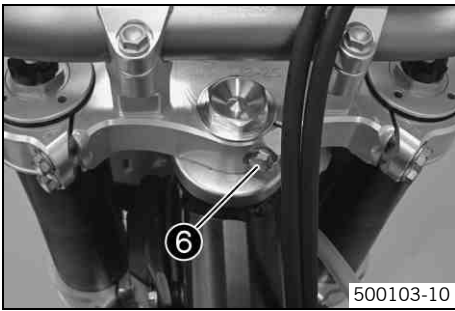

Guideline

Screw, top steering stem	M8	17 Nm (12.5 lbf ft)	Loctite® 243™
--------------------------	----	------------------------	---------------

- Check the cable harness, cable, brake and clutch line for free movement and free laying.
- Check play of steering head bearing. (☛ p. 46)

Installing the lower triple clamp ☛ (EXC-F EU, EXC-F AUS, XCF-W ZA)

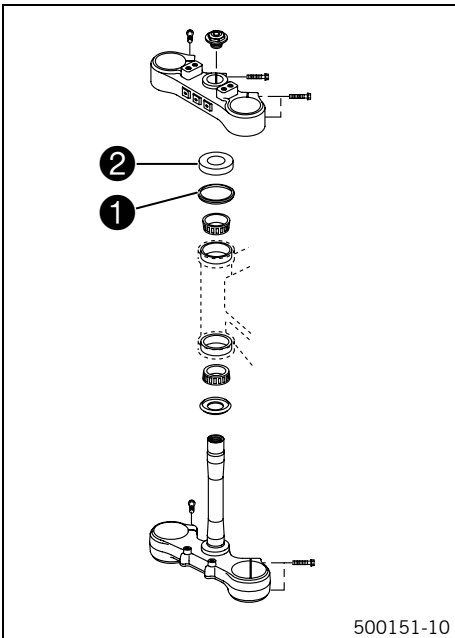

- Clean the bearing and sealing elements, check for damage, and grease.

Long-life grease (☛ p. 117)

- Insert the lower triple clamp with the steering stem. Mount the upper steering head bearing.

i Info

Check whether the top steering head seal ① is correctly positioned.

- Push on protective ring ②.

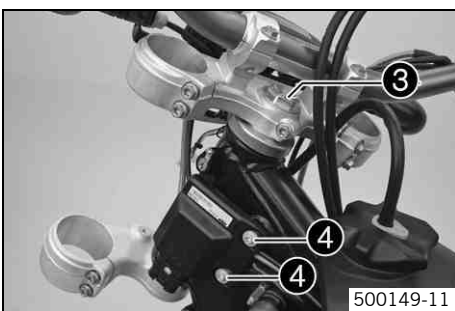

- Position the upper triple clamp with the steering.
- Mount and tighten screw ③.

Guideline

Screw, top steering head	M20x1.5	10 Nm (7.4 lbf ft)
--------------------------	---------	--------------------

- Position the clutch line, wiring harness and CDI control unit. Mount and tighten screws ④.

Guideline

Remaining screws, chassis	M6	10 Nm (7.4 lbf ft)
---------------------------	----	--------------------

- Install the front fender. (☛ p. 53)
- Refit the headlight mask with the headlight. (☛ p. 54)
- Install the fork legs. ☛ (☛ p. 49)
- Tighten screw ⑤.

Guideline

Screw, top steering stem	M8	20 Nm (14.8 lbf ft)
--------------------------	----	------------------------

- Check the cable harness, cable, brake and clutch line for free movement and free laying.
- Check play of steering head bearing. (☛ p. 46)

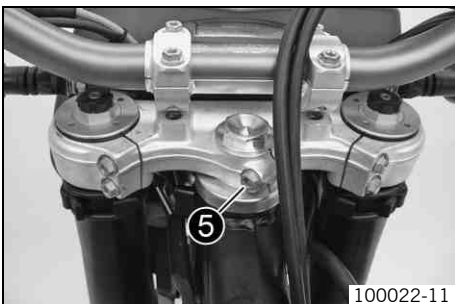

Greasing the steering head bearing

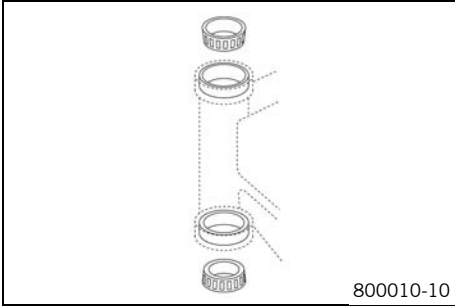

(EXC-F SIX DAYS, XCF-W USA, XC-F, SX-F)

- Remove the lower triple clamp. (p. 50)
- Install the lower triple clamp. (p. 51)

(EXC-F EU, EXC-F AUS, XCF-W ZA)

- Remove the lower triple clamp. (p. 51)
- Install the lower triple clamp. (p. 52)

Dismounting the front fender

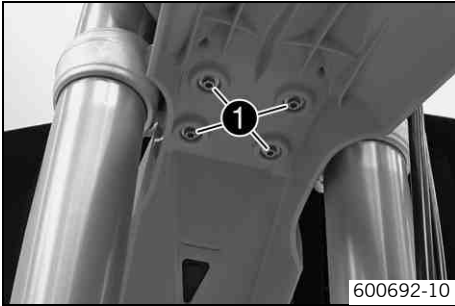

- Remove screws ❶. Remove the front fender.
- Make sure that the distance bushings remain in place.

Installing the front fender

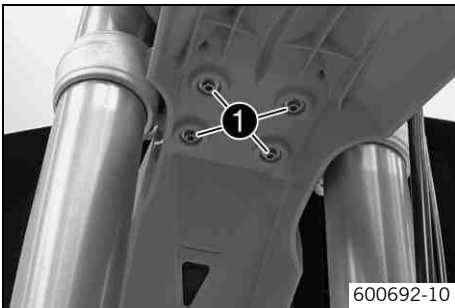

- Ensure that the spacing sleeves are mounted in the fender.
- Position the front fender. Mount and tighten screws ❶.

Guideline

Remaining screws, chassis	M6	10 Nm (7.4 lbf ft)
---------------------------	----	--------------------

i Info

Take care with the contact between the holding lugs and the start number plate or headlight mask.

Removing headlight mask with headlight (EXC-F, EXC-F SIX DAYS, XCF-W ZA)

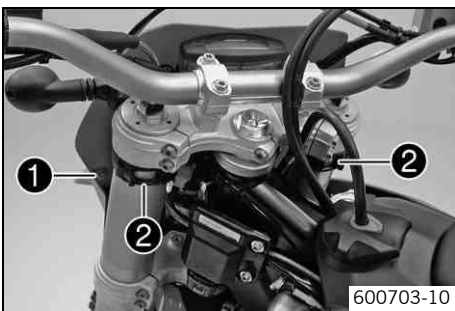

- Switch off all electrical equipment.
- Remove screw ❶ and take off clamp.
- Loosen the rubber band ❷. Push up the headlight mask and swing it forwards.

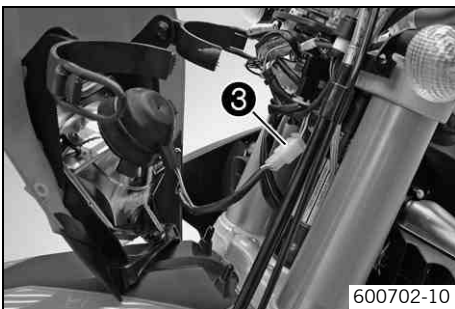

- Pull out the electric plug connector ❸ and remove the headlight mask with the headlight.

Refitting the headlight mask with the headlight (EXC-F, EXC-F SIX DAYS, XCF-W ZA)

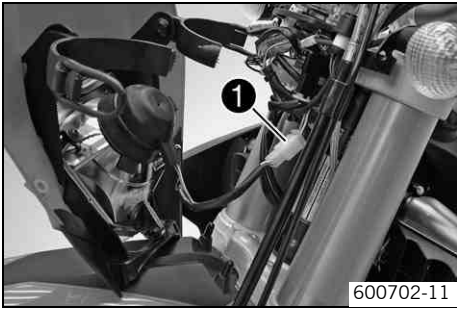

- Connect the electric plug connector ❶.

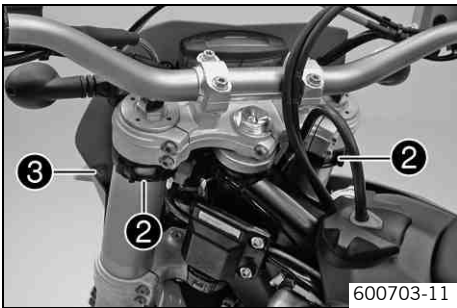

- Position the headlight mask and fix it with the rubber band ❷.

i Info

Take care with the contact of the holding lug at the fender.

- Position the brake line and cable harness. Put the clamp on, mount and tighten screw ❸.
- Check the headlamp setting.

Dismount the start number plate (XCF-W USA, XC-F, SX-F)

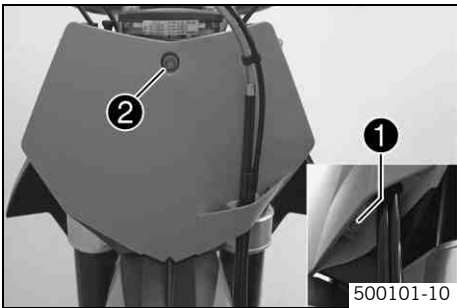

- Remove screw ❶ and take off clamp.
- Remove screw ❷ with the spacing sleeve. Remove the start number plate.

Installing the start number plate (XCF-W USA, XC-F, SX-F)

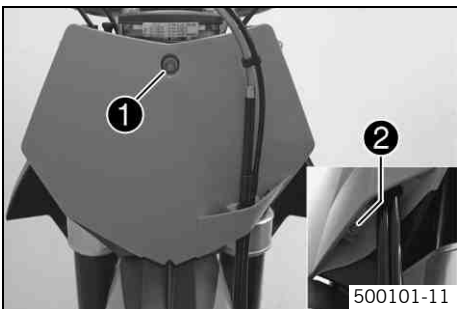

- Position the start number plate. Mount and tighten screw ❶ with the spacing sleeve.

Guideline

Remaining screws, chassis	M6	10 Nm (7.4 lbf ft)
---------------------------	----	--------------------

i Info

Take care with the contact of the holding lug at the fender.

- Position the brake line and cable harness. Put the clamp on, mount and tighten screw ❷.

Handlebar position

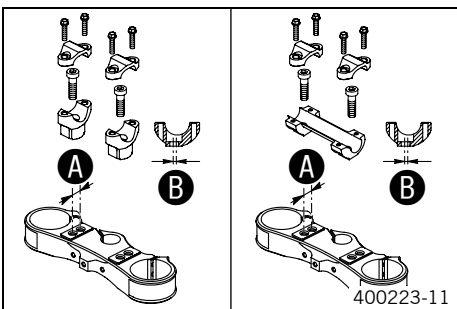

On the upper triple clamp, there are 2 holes at a distance of **A** to each other.

Distance A between holes	15 mm (0.59 in)
---------------------------------	-----------------

The holes on the handlebar support are placed at a distance of **B** from the center.

Distance B between holes	3.5 mm (0.138 in)
---------------------------------	-------------------

The handlebar supports can be mounted in 4 different positions.

(250 EXC-F SIX DAYS EU)

The handlebar supports can also be mounted at 2 different heights (with and without spacer).

Thick spacer	9 mm (0.35 in)
--------------	----------------

Adjusting the handlebar position ↩

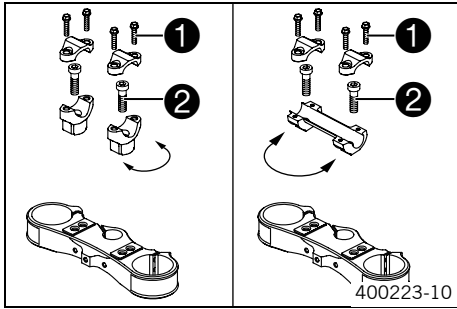

(EXC-F EU, EXC-F AUS, XCF-W, XC-F, SX-F)

- Remove the four screws ❶. Remove the handlebar clamp. Remove the handlebar and lay it to one side.

i Info
Protect the motorcycle and its attachments from damage by covering them.
Do not bend the cables and lines.

- Remove the two screws ❷. Remove the handlebar support.
- Place the handlebar support in the required position. Mount and tighten the two screws ❷.

Guideline

Screw, handlebar support	M10	40 Nm (29.5 lbf ft)	Loctite® 243™
--------------------------	-----	------------------------	----------------------

i Info
Position evenly the left and right handlebar supports.

- Position the handlebar.

i Info
Make sure cables and wiring are positioned correctly.

- Position the handlebar clamp. Mount and evenly tighten the four screws ❶.

Guideline

Screw, handlebar clamp	M8	20 Nm (14.8 lbf ft)	
------------------------	----	------------------------	--

i Info
Make sure the gap width is even.

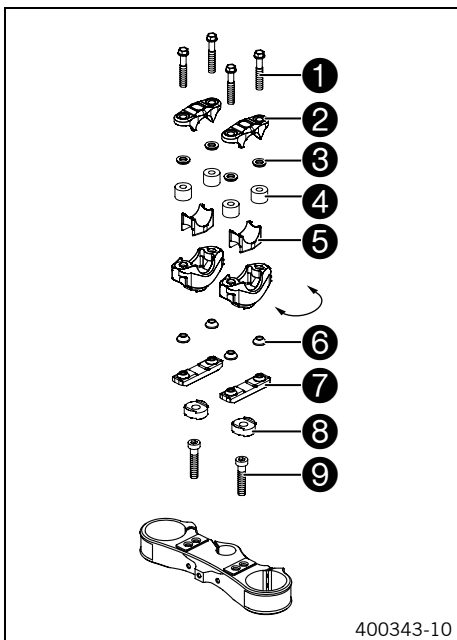

(250 EXC-F SIX DAYS EU)

- Remove the four screws ❶. Remove the handlebar clamps ❷ with rubber washers ❸ and elastomers ❹.
- Remove the handlebar and lay it to one side.

i Info
Protect the motorcycle and its attachments from damage by covering them.
Do not bend the cables and lines.

- Remove lower shells ❺.
- Remove clamp bar ❽ with rubber cones ❻.
- Remove the two screws ❹. Remove the handlebar support.
- Place the handlebar support in the required position. Mount and tighten the two screws ❹.

Guideline

Screw, handlebar support	M10	40 Nm (29.5 lbf ft)	Loctite® 243™
--------------------------	-----	------------------------	----------------------

Condition

Spacer ❸ fitted:

Use a M10x35 screw

Condition

without spacer ❸:

Use a M10x25 screw

i Info
Position evenly the left and right handlebar supports.

- Mount rubber cones ❻ and clamp bar ❽.

- Mount lower shells ⑤.
- Position the handlebar.

i Info
Make sure cables and wiring are positioned correctly.

- Position handlebar clamps ② with rubber washers ③ and elastomers ④.

Elastomer kit green - soft quality (SXS05125203)
Elastomer kit yellow - medium quality (standard) (SXS05125204)
Elastomer kit red - hard quality (SXS05125205)

i Info
The elastomers are available in different versions.

- Mount and evenly tighten the four screws ①.

Guideline

Screw, handlebar clamp	M8	16 Nm (11.8 lbf ft)
------------------------	----	------------------------

i Info
Make sure the gap width is even.

Checking gas Bowden cable route



600672-10

- The two gas Bowden cables must run parallel behind the handlebar down to the frame. They must be routed directly on the frame above the tank bearing to the carburetor.

Checking play in the gas Bowden cable

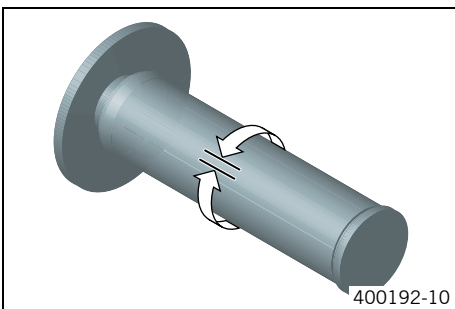

400192-10

- Move the handlebar to the straight-ahead position. Move the throttle grip back and forth slightly to ascertain the play in the gas Bowden cable.

Play in gas Bowden cable	3... 5 mm (0.12... 0.2 in)
--------------------------	----------------------------

- » If the gas Bowden cable play does not meet specifications:
 - Adjust the gas Bowden cable play. (🔧 p. 57)



Danger

Danger of poisoning Exhaust gases are poisonous and can result in unconsciousness and/or death.

- When running the engine, always make sure there is sufficient ventilation, and do not start or run the engine in a closed space.

- Start the engine and let it run idle. Move the handlebar to and fro over the entire steering range.

The idle speed must not change.

- » If the idle speed changes:
 - Adjust the gas Bowden cable play. 🛠️ (☞ p. 57)

Adjusting the gas Bowden cable play 🛠️

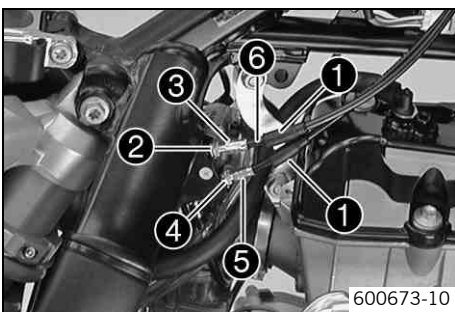

600673-10

- Dismount the fuel tank. 🛠️ (☞ p. 78)
- Check gas Bowden cable route. (☞ p. 56)
- Move the handlebar to the straight-ahead position.
- Push back bellows ❶.
- Loosen nut ❷. Turn adjusting screw ❸ in as far as possible.
- Loosen nut ❹. Turn adjusting screw ❺ so that there is play in the gas Bowden cable at the throttle grip.

Guideline

Play in gas Bowden cable	3... 5 mm (0.12... 0.2 in)
--------------------------	----------------------------

- Tighten nut ❹.
- Press and hold the throttle grip in the closed setting. Turn adjusting screw ❸ out until there is no play in the Bowden cable ❻.
- Tighten nut ❷.
- Push bellows ❶ on. Check the throttle grip for smooth operation.
- Install the fuel tank. 🛠️ (☞ p. 79)
- Check play in the gas Bowden cable. (☞ p. 56)

Checking for chain dirt accumulation

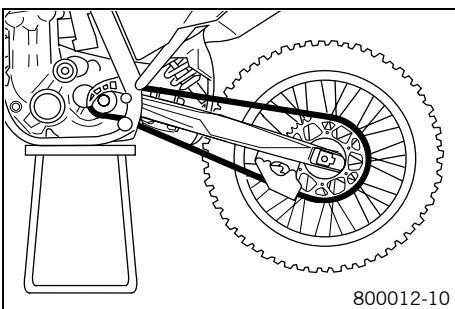

800012-10

- Check the chain for coarse dirt accumulation.
 - » If the chain is very dirty:
 - Clean the chain. (☞ p. 57)

Cleaning the chain



Warning

Danger of accidents Oil or grease on the tires reduces their grip.

- Remove oil and grease with a suitable cleaning material.



Warning

Danger of accidents Reduced braking due to oil or grease on the brake discs.

- Always keep the brake discs free of oil and grease, and clean them with brake cleaner when necessary.



Warning

Environmental hazard Problem materials cause environmental damage.

- Dispose of oil, grease, filters, fuel, cleaning substances, brake fluid, batteries, etc. according to regulations.



Info

The service life of the chain depends largely on its maintenance.

- Clean the chain regularly and then treat with chain spray.

Chain cleaner (☛ p. 117)

Offroad chain spray (☛ p. 117)

Checking the chain tension



Warning

Danger of accidents Danger caused by incorrect chain tension.

- If the chain tension is too high, the components of the secondary power train (chain, engine sprocket, rear sprocket, bearings in transmission and rear wheel) are under additional load. Apart from premature wear, in extreme cases the chain can rupture or the countershaft of the transmission can break. On the other hand, if the chain is loose, it can fall off the engine sprocket or the rear sprocket and block the rear wheel or damage the engine. Check for correct chain tension and adjust if necessary.

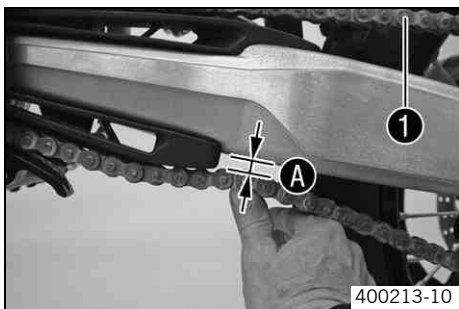

- Jack up the motorcycle. (☛ p. 37)
- Push the chain at the end of the chain sliding component upwards to measure the chain tension **A**.



Info

The upper chain section **1** must be taut.

Chain wear is not always even, so you should repeat this measurement at different chain positions.

Chain tension	8... 10 mm (0.31... 0.39 in)
---------------	------------------------------

- » If the chain tension does not meet specifications:
 - Adjusting chain tension - after checking. (☛ p. 60)
- Remove the motorcycle from the work stand. (☛ p. 37)

Checking the chain tension when fitting rear wheel



Warning

Danger of accidents Danger caused by incorrect chain tension.

- If the chain tension is too high, the components of the secondary power train (chain, engine sprocket, rear sprocket, bearings in transmission and rear wheel) are under additional load. Apart from premature wear, in extreme cases the chain can rupture or the countershaft of the transmission can break. On the other hand, if the chain is loose, it can fall off the engine sprocket or the rear sprocket and block the rear wheel or damage the engine. Check for correct chain tension and adjust if necessary.

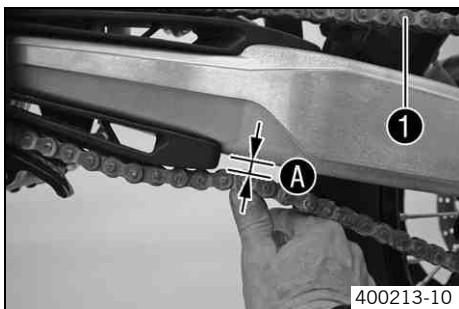

- Make sure that the chain adjusters are fitted correctly on the adjusting screws.
- Push the chain at the end of the chain sliding component upwards to measure chain tension **A**.



Info

The upper chain section **1** must be taut.

Chain wear is not always even, so you should repeat this measurement at different chain positions.

Chain tension	8... 10 mm (0.31... 0.39 in)
---------------	------------------------------

- » If the chain tension does not meet specifications:
 - Adjust the chain tension when fitting rear wheel. (☛ p. 61)

Checking the rear sprocket / engine sprocket for wear

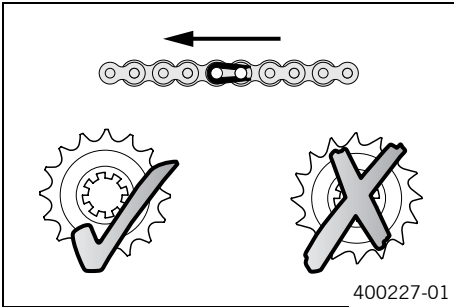

- Check the rear sprocket / engine sprocket for wear.
 - » If the rear sprocket / engine sprocket are worn:
 - Replace rear sprocket / engine sprocket.



Info

When fitting the chain joint, always make sure that the closed side of the joint faces forward (riding direction). The engine sprocket, rear sprocket and chain should always be replaced together.

- Check that the chain guide is firmly seated and not worn.

Checking chain wear

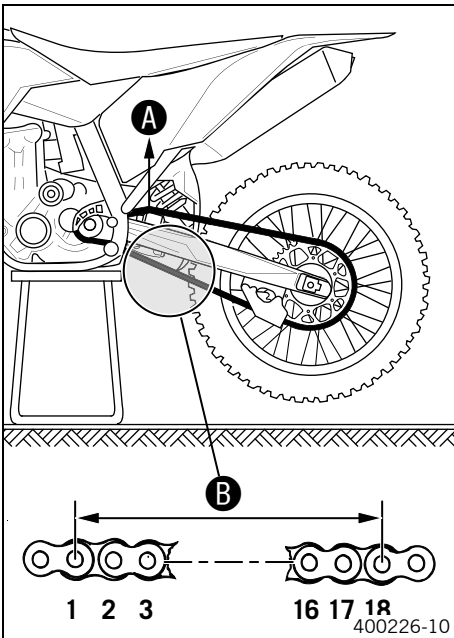

- Jack up the motorcycle. (☛ p. 37)
- Shift gear to neutral.
- Pull the upper chain section with the specified weight **A**.

Guideline

Weight of chain wear measurement	10... 15 kg (22... 33 lb.)
----------------------------------	----------------------------

- Measure distance **B** of 18 chain links in the lower chain section.



Info

Chain wear is not always even, so you should repeat this measurement at different chain positions.

Maximum distance B at the longest chain section	272 mm (10.71 in)
--	-------------------

- » If the distance **B** is greater than the specified measurement:
 - Replace the chain.



Info

When you replace the chain, you should also replace the rear sprocket and the engine sprocket. New chains wear out faster on old, worn sprockets.

- Remove the motorcycle from the work stand. (☛ p. 37)

Adjusting the chain tension



Warning

Danger of accidents Danger caused by incorrect chain tension.

- If the chain tension is too high, the components of the secondary power train (chain, engine sprocket, rear sprocket, bearings in transmission and rear wheel) are under additional load. Apart from premature wear, in extreme cases the chain can rupture or the countershaft of the transmission can break. On the other hand, if the chain is loose, it can fall off the engine sprocket or the rear sprocket and block the rear wheel or damage the engine. Check for correct chain tension and adjust if necessary.

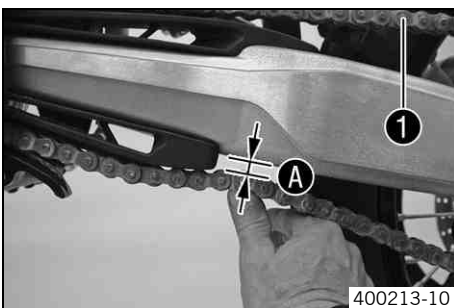

- Jack up the motorcycle. (☛ p. 37)
- Push the chain at the end of the chain sliding component upwards to measure chain tension **A**.



Info

The upper chain section **1** must be taut. Chain wear is not always even, so you should repeat this measurement at different chain positions.

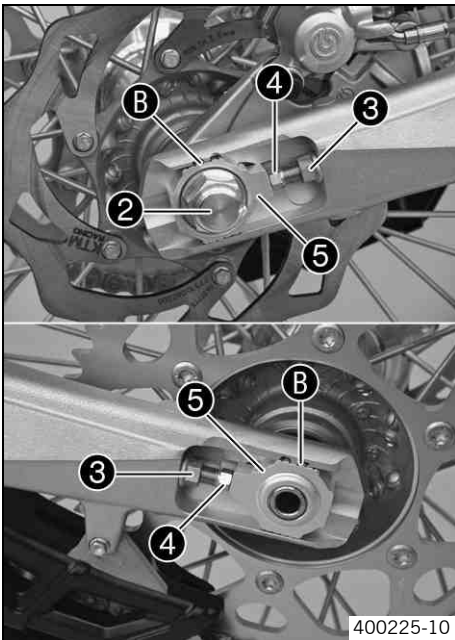

- Loosen nut ②.
- Loosen nuts ③.
- Adjust the chain tension by turning the left and right adjusting screws ④.

Guideline

Chain tension	8... 10 mm (0.31... 0.39 in)	
Turn the left and right adjusting screws ④ so that the markings on the left and right chain adjusters are in the same position relative to the reference marks ③. The rear wheel is then correctly aligned.		

- Tighten nuts ③.
- Make sure that chain adjusters ⑤ are fitted correctly on the adjusting screws ④.
- Tighten nut ②.

Guideline

Nut, rear wheel spindle	M20x1.5	80 Nm (59 lbf ft)
-------------------------	---------	-------------------

i Info
The wide adjustment range of the chain adjusters (32 mm) enables different secondary transmissions with the same chain length. Chain adjusters ⑤ can be turned by 180°.

- Remove the motorcycle from the work stand. (☛ p. 37)

Adjusting chain tension - after checking

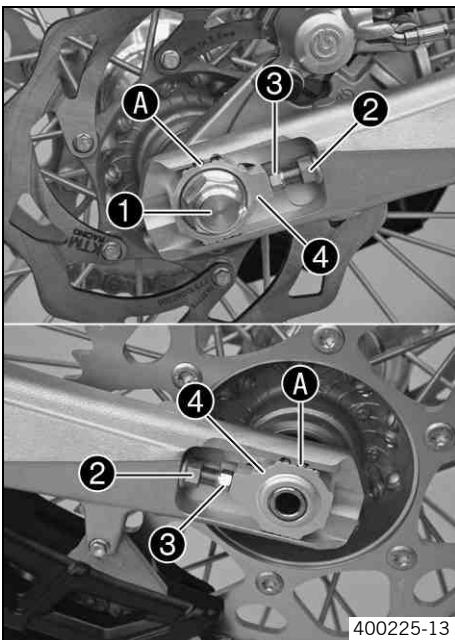

- Loosen nut ①.
- Loosen nuts ②.
- Adjust the chain tension by turning the adjusting screws ③ left and right.

Guideline

Chain tension	8... 10 mm (0.31... 0.39 in)	
Turn the adjusting screws ③ left and right so that the markings on the left and right chain adjusters are in the same position relative to the reference marks ④. The rear wheel is then correctly aligned.		

- Tighten nuts ②.
- Make sure that the chain adjusters ④ are fitted correctly on the adjusting screws ③.
- Tighten nut ①.

Guideline

Nut, rear wheel spindle	M20x1.5	80 Nm (59 lbf ft)
-------------------------	---------	-------------------

i Info
The wide adjustment range of the chain adjusters (32 mm) enables different secondary transmissions with the same chain length. The chain adjusters ④ can be turned by 180°.

Adjusting chain tension - fitting rear wheel

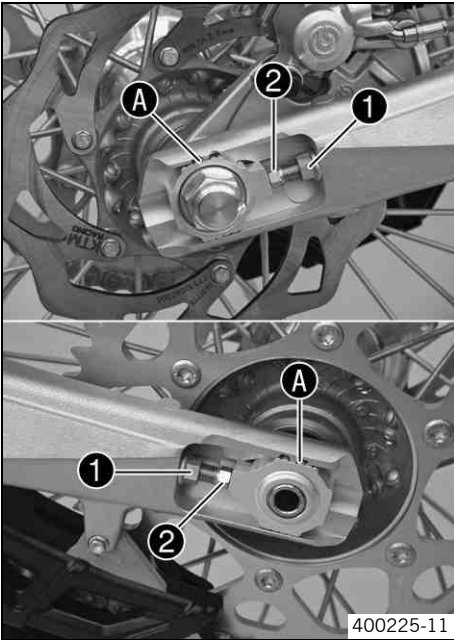

- Loosen nuts ❶.
- Adjust the chain tension by turning the adjusting screws ❷ left and right.

Guideline

Chain tension	8... 10 mm (0.31... 0.39 in)
Turn the adjusting screws ❷ left and right so that the markings on the left and right chain adjusters are in the same position relative to the reference marks A. The rear wheel is then correctly aligned.	

- Tighten nuts ❶.

Adjusting the chain guide ↻ (EXC-F, EXC-F SIX DAYS, XCF-W, XC-F)

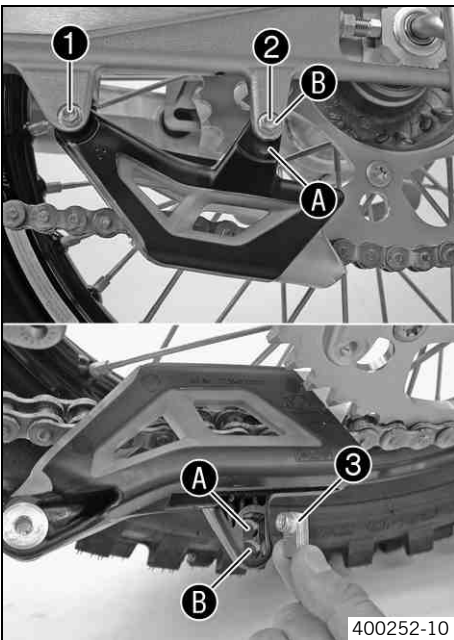

- Remove screws ❶ and ❷. Take off the chain guide.

Condition

Number of teeth: ≤ 44 teeth

- Insert nut ❸ in hole A. Position the chain guide.
- Mount and tighten screws ❶ and ❷.

Guideline

Remaining screws, chassis	M6	10 Nm (7.4 lbf ft)
---------------------------	----	-----------------------

Condition

Number of teeth: ≥ 45 teeth

- Insert nut ❸ in hole B. Position the chain guide.
- Mount and tighten screws ❶ and ❷.

Guideline

Remaining screws, chassis	M6	10 Nm (7.4 lbf ft)
---------------------------	----	-----------------------

Adjusting the chain guide ↩ (SX-F)

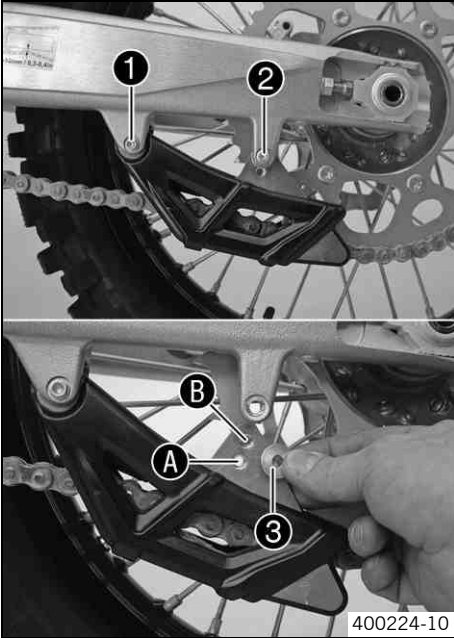

- Loosen screw ❶. Remove screw ❷. Push the chain guide down.

Condition

Number of teeth: ≤ 44 teeth

- Insert collar sleeve ❸ in hole ❹. Position the chain guide.
- Mount and tighten screw ❷. Tighten screw ❶.

Guideline

Remaining screws, chassis	M6	10 Nm (7.4 lbf ft)
---------------------------	----	-----------------------

Condition

Number of teeth: ≥ 45 teeth

- Insert collar sleeve ❸ in hole ❺. Position the chain guide.
- Mount and tighten screw ❷. Tighten screw ❶.

Guideline

Remaining screws, chassis	M6	10 Nm (7.4 lbf ft)
---------------------------	----	-----------------------

Adjusting basic position of clutch lever

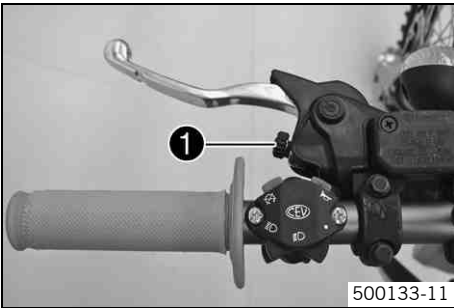

- Adjust the basic setting of the clutch lever to your hand size by turning adjusting screw ❶.

Info

Turn the adjusting screw clockwise to increase the distance between the clutch lever and the handlebar.
Turn the adjusting screw counterclockwise to decrease the distance between the clutch lever and the handlebar.
The range of adjustment is limited.
Turn the adjusting screw by hand only, and do not apply any force.
Do not make any adjustments while riding!

Checking the fluid level of hydraulic clutch

Warning

Skin irritations Brake fluid can cause skin irritation on contact.

- Avoid contact with skin and eyes, and keep out of the reach of children.
- If brake fluid gets into your eyes, rinse thoroughly with water and contact a doctor immediately.

Info

The fluid level rises with increasing wear of the clutch lining disc.
Avoid contact between brake fluid and painted parts. Brake fluid attacks paint!
Use only clean brake fluid from a sealed container!

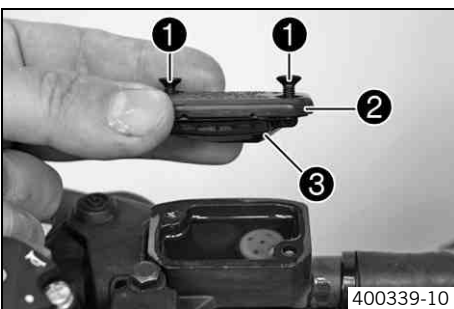

- Move the clutch fluid reservoir mounted on the handlebar to a horizontal position.
- Remove screws ❶.
- Remove cover ❷ with membrane ❸.
- Check the fluid level.

Fluid level under top level of container.	4 mm (0.16 in)
---	----------------

- » If the level of the fluid does not meet specifications:
 - Correct the fluid level of the hydraulic clutch.

Brake fluid DOT 4 / DOT 5.1 (☛ p. 116)
--

- Position the cover with the membrane. Mount and tighten the screws.

i Info
Clean up overflowed or spilt fluid immediately with water.

Changing the hydraulic clutch fluid

Warning
Skin irritations Brake fluid can cause skin irritation on contact.

- Avoid contact with skin and eyes, and keep out of the reach of children.
- If brake fluid gets into your eyes, rinse thoroughly with water and contact a doctor immediately.

Warning
Environmental hazard Problem materials cause environmental damage.

- Dispose of oil, grease, filters, fuel, cleaning substances, brake fluid, batteries, etc. according to regulations.

i Info
The fluid level rises with increasing wear of the clutch lining disc.
Avoid contact between brake fluid and painted parts. Brake fluid attacks paint!
Use only clean brake fluid from a sealed container!

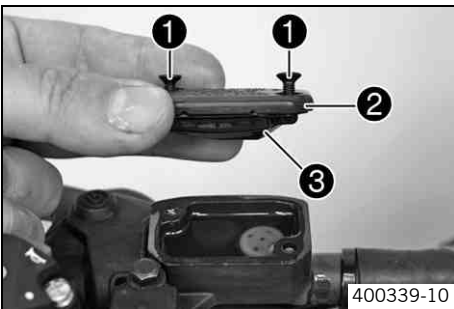

- Move the clutch fluid reservoir mounted on the handlebar to a horizontal position.
- Remove screws 1.
- Remove cover 2 with membrane 3.

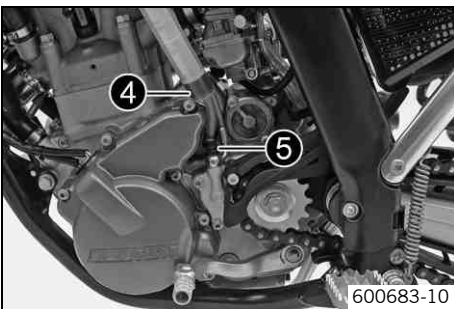

- Fill bleeding syringe 4 with the appropriate hydraulic fluid.

Bleed syringe (50329050000)

Brake fluid DOT 4 / DOT 5.1 (☞ p. 116)
--

- On the slave cylinder, remove bleeder screw 5 and mount bleeding syringe 4.

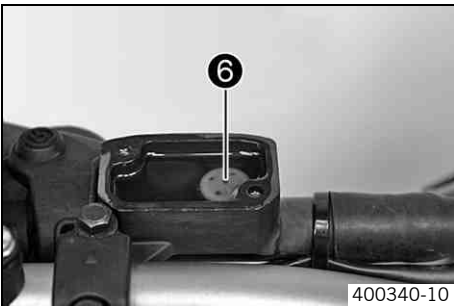

- Inject the liquid into the system until it escapes from bore hole 6 of the master cylinder without bubbles.
- To prevent overflow, drain fluid occasionally from the master cylinder reservoir.
- Remove the bleeding syringe. Mount and tighten screws bleeder screw.
- Correct the fluid level of the hydraulic clutch.

Guideline

Fluid level under top level of container.	4 mm (0.16 in)
---	----------------

- Position the cover with the membrane. Mount and tighten the screws.

i Info
Clean up overflowed or spilt fluid immediately with water.

Checking the brake discs

Warning
Danger of accidents Reduced braking due to worn brake discs.

- Worn brake discs should be replaced immediately in an authorized KTM workshop.

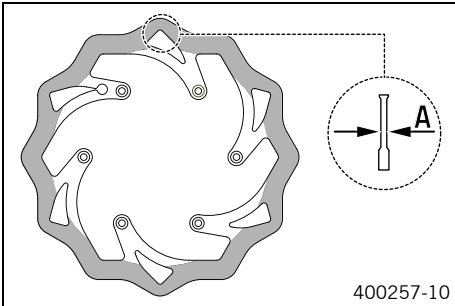

- Check the thickness of the front and rear brake discs at several places on the disc to see if it conforms to measurement **A**.

i Info
 Wear reduces the thickness of the brake disc around the area used by the brake linings.

Wear limit of brake discs	
Front	2.5 mm (0.098 in)
Rear	3.5 mm (0.138 in)

- » If the brake disc thickness is less than the specified value:
 - Change the brake disc.

Checking free travel of hand brake lever

Warning
Danger of accidents Brake system failure.

- If there is no free travel on the hand brake lever, pressure builds up on the front brake in the brake system. The front brake can fail due to overheating. Adjust free travel on hand brake lever according to specifications.

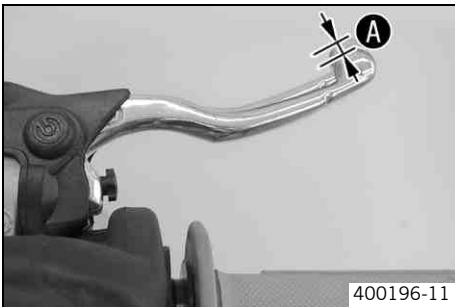

(XCF-W, XC-F, SX-F)

- Push the hand brake lever forwards and check free travel **A**.

Free travel of hand brake lever	≥ 3 mm (≥ 0.12 in)
---------------------------------	--------------------

- » If the free travel does not meet specifications:
 - Adjust the basic position of handbrake lever. (☛ p. 64)



(EXC-F, EXC-F SIX DAYS)

- Push the hand brake to the handlebar and check free travel **A**.

Free travel of hand brake lever	≥ 3 mm (≥ 0.12 in)
---------------------------------	--------------------

- » If the free travel does not meet specifications:
 - Adjust the free travel of the handbrake lever. (☛ p. 65)

Adjusting basic position of handbrake lever (XCF-W, XC-F, SX-F)

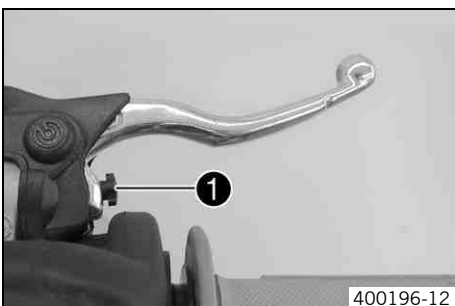

- Adjust the basic setting of the handbrake lever to your hand size by turning adjusting screw **1**.

i Info
 Turn the adjusting screw clockwise to increase the distance between the handbrake lever and the handlebar.
 Turn the adjusting screw counterclockwise to decrease the distance between the handbrake lever and the handlebar.
 The range of adjustment is limited.
 Turn the adjusting screw by hand only, and do not apply any force.
 Do not make any adjustments while riding!

- Check the free travel of the hand brake lever. (☛ p. 64)

Adjusting free travel of handbrake lever (EXC-F, EXC-F SIX DAYS)

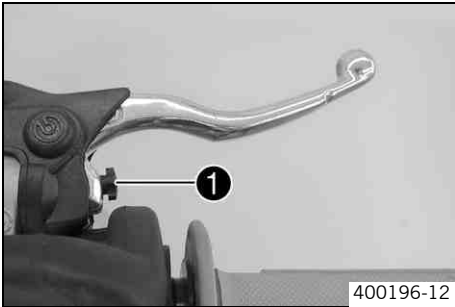

- Adjust the free travel of the handbrake lever with the adjustment screw ❶.

Info

Turn the adjustment screw clockwise to reduce free travel. The pressure point moves away from the handlebar.
 Turn the adjustment screw counterclockwise to increase free travel. The pressure point moves towards the handlebar.
 The range of adjustment is limited.
 Turn the adjusting screw by hand only, and do not apply any force.
 Do not make any adjustments while riding!

- Check the free travel of the hand brake lever. (☞ p. 64)

Checking the front brake fluid level

Warning
Danger of accidents Brake system failure.

- **MIN** If the brake fluid level falls below the MIN mark, this indicates a leakage in the brake system or worn-out brake linings. Have the brake system checked in an authorized KTM workshop, and do not ride any further.

Warning
Danger of accidents Reduced braking due to old brake fluid.

- Have the front and rear brake fluid replaced according to the service plan in an authorized KTM workshop.

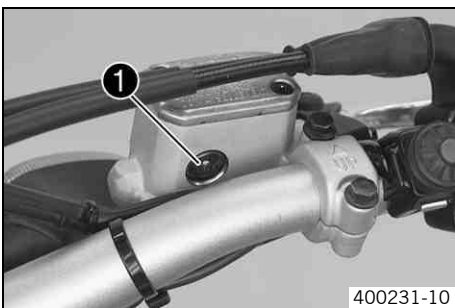

- Move the brake fluid reservoir mounted on the handlebar to a horizontal position.
- Check the brake fluid level in the viewer ❶.
 - » If the brake fluid is below the **MIN** mark:
 - Add front brake fluid. ☞ (☞ p. 65)

Adding front brake fluid ☞

Warning
Danger of accidents Brake system failure.

- **MIN** If the brake fluid level falls below the MIN mark, this indicates a leakage in the brake system or worn-out brake linings. Have the brake system checked in an authorized KTM workshop, and do not ride any further.

Warning
Skin irritations Brake fluid can cause skin irritation on contact.

- Avoid contact with skin and eyes, and keep out of the reach of children.
- If brake fluid gets into your eyes, rinse thoroughly with water and contact a doctor immediately.

Warning
Danger of accidents Reduced braking due to old brake fluid.

- Have the front and rear brake fluid replaced according to the service plan in an authorized KTM workshop.

Warning
Environmental hazard Problem materials cause environmental damage.

- Dispose of oil, grease, filters, fuel, cleaning substances, brake fluid, batteries, etc. according to regulations.

Info
 Never use DOT 5 brake fluid! This is based on silicone oil and is colored purple. Oil seals and brake lines are not designed for DOT 5 brake fluid.
 Avoid contact between brake fluid and painted parts. Brake fluid attacks paint!
 Use only clean brake fluid from a sealed container!

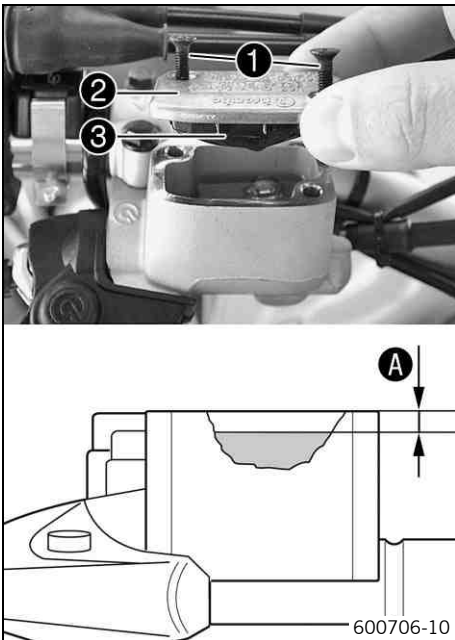

- Move the brake fluid reservoir mounted on the handlebar to a horizontal position.
- Remove screws ❶.
- Remove cover ❷ with membrane ❸.
- Add brake fluid to level A.

Guideline

Measurement of A	5 mm (0.2 in)
------------------	---------------

Brake fluid DOT 4 / DOT 5.1 (☞ p. 116)
--

- Position the cover with the membrane. Mount and tighten the screws.

i Info
Clean up overflowed or spilt brake fluid immediately with water.

Checking the front brake linings

⚠ Warning
Danger of accidents Reduced braking due to worn brake linings.

- Worn brake linings should be replaced immediately in an authorized KTM workshop.

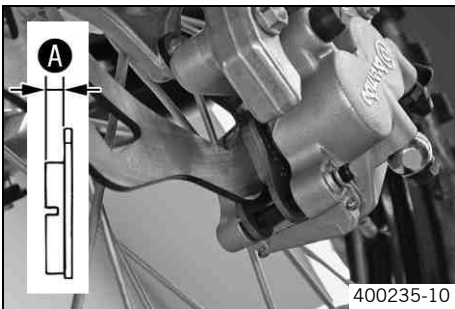

- Check the brake linings for minimum thickness A.

Minimum thickness A	≥ 1 mm (≥ 0.04 in)
---------------------	--------------------

- » If the minimum thickness is less than specified:
 - Change the front brake linings. ☞ (☞ p. 67)

Removing the front brake linings

⚠ Warning
Danger of accidents Improper brake maintenance and repair.

- Always have your brake system maintained and repaired in an authorized KTM workshop.

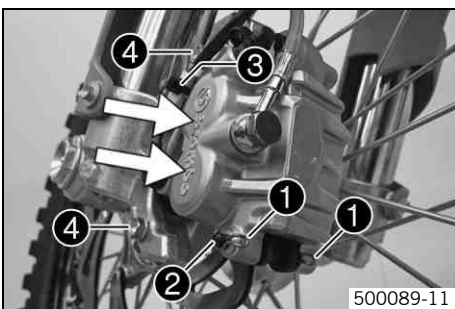

- Press the brake caliper by hand on to the brake disc in order to press back the brake pistons.

i Info
Make sure when pushing back the brake pistons that you do not press the brake caliper against the spokes.

- Remove locking split pins ❶, withdraw bolt ❷, and take out the brake pads.

(EXC-F, EXC-F SIX DAYS, XCF-W)

- Remove cable clip ❸.
- Remove screws ❹ and take off brake caliper.
- Clean the brake caliper and brake caliper support.

Installing the front brake linings



Warning

Danger of accidents Reduced braking due to oil or grease on the brake discs.

- Always keep the brake discs free of oil and grease, and clean them with brake cleaner when necessary.



Warning

Danger of accidents Reduced braking due to use of non-approved brake linings.

- Brake linings available from accessory suppliers are often not tested and approved for use on KTM vehicles. The construction and friction factor of the brake linings and therefore the brake power can differ considerably from the original KTM brake linings. If brake linings are used that differ from the originals, there is no guarantee that they comply with the original license. The vehicle no longer corresponds to the condition at delivery, and the warranty is no longer valid.

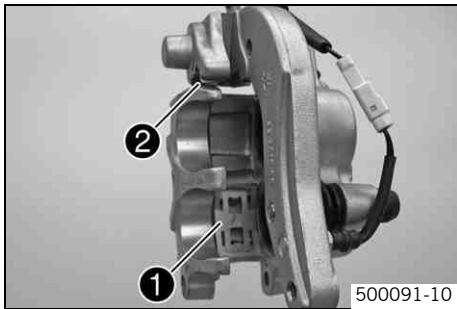

- Check the brake discs. ( p. 64)
- Check that leaf spring **1** in the brake caliper and sliding plate **2** in the brake caliper support are seated correctly.



Info

The arrow on the leaf spring points in the rotation direction of the brake disc.

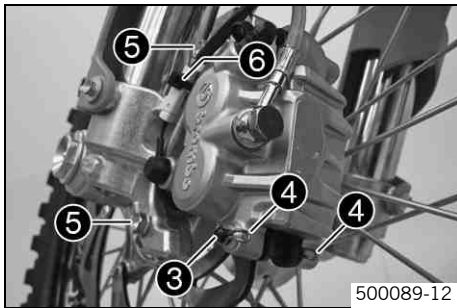

- Fit the brake pads, insert bolt **6**, and mount locking split pins **4**.
- Position the brake caliper, and mount and tighten screws **5**.

Guideline

Screw, front brake caliper	M8	25 Nm (18.4 lbf ft)	Loctite® 243™
----------------------------	----	------------------------	----------------------

(EXC-F, EXC-F SIX DAYS, XCF-W)

- Mount cable clip **3**.
- Operate the hand brake lever repeatedly until the brake linings lie on the brake disc and there is a tight spot.

Changing the front brake linings



Warning

Skin irritations Brake fluid can cause skin irritation on contact.

- Avoid contact with skin and eyes, and keep out of the reach of children.
- If brake fluid gets into your eyes, rinse thoroughly with water and contact a doctor immediately.



Warning

Danger of accidents Reduced braking due to old brake fluid.

- Have the front and rear brake fluid replaced according to the service plan in an authorized KTM workshop.



Warning

Environmental hazard Problem materials cause environmental damage.

- Dispose of oil, grease, filters, fuel, cleaning substances, brake fluid, batteries, etc. according to regulations.



Info

Never use DOT 5 brake fluid! This is based on silicone oil and is colored purple. Oil seals and brake lines are not designed for DOT 5 brake fluid.

Avoid contact between brake fluid and painted parts. Brake fluid attacks paint!

Use only clean brake fluid from a sealed container!

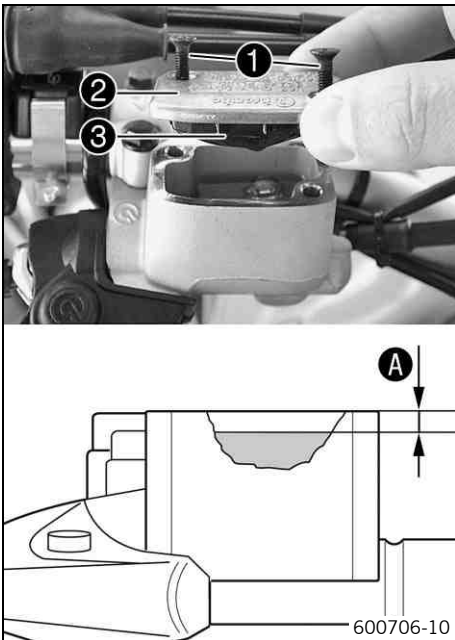

- Remove the front brake linings. ↩ (☞ p. 66)
- Move the brake fluid reservoir mounted on the handlebar to a horizontal position.
- Remove screws ❶.
- Remove cover ❷ with membrane ❸.
- Press the brake piston back to its basic position and make sure that no brake fluid overflows from the brake fluid reservoir.
- Install the front brake linings. ↩ (☞ p. 67)
- Add brake fluid to level A.

Guideline

Measurement of A	5 mm (0.2 in)
------------------	---------------

Brake fluid DOT 4 / DOT 5.1 (☞ p. 116)
--

- Position the cover with the membrane. Mount and tighten the screws.

i Info
Clean up overflowed or spilt brake fluid immediately with water.

Checking free travel of foot brake lever

Warning
Danger of accidents Brake system failure.

- If there is no free travel on the foot brake pedal, pressure builds up on the rear brake in the brake system. The rear brake can fail due to overheating. Adjust free travel on foot brake pedal according to specifications.

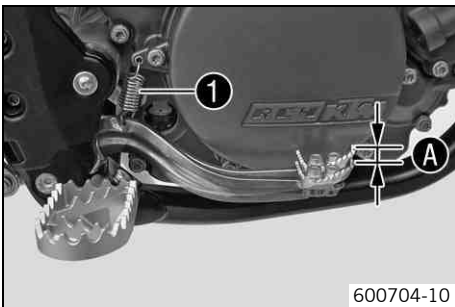

- Disconnect spring ❶.
- Move the foot brake lever backwards and forwards between the end stop and the foot brake cylinder piston bracket and check free travel A.

Guideline

Free travel at foot brake lever	3... 5 mm (0.12... 0.2 in)
---------------------------------	----------------------------

- » If the free travel does not meet specifications:
 - Adjust the basic position of the footbrake lever. ↩ (☞ p. 68)
- Reconnect spring ❶.

Adjusting basic position of footbrake lever ↩

Warning
Danger of accidents Brake system failure.

- If there is no free travel on the foot brake pedal, pressure builds up on the rear brake in the brake system. The rear brake can fail due to overheating. Adjust free travel on foot brake pedal according to specifications.

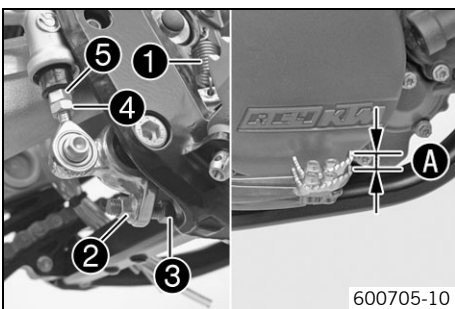

- Disconnect spring ❶.
- Loosen nut ❷ and with push rod ❸, turn it back until you have maximum free travel.
- To adjust the basic position of the footbrake lever individually, loosen nut ❷ and turn screw ❸ accordingly.

i Info
The range of adjustment is limited.

- Turn push rod ❸ accordingly until you have free travel A. If necessary, adjust the basic position of the footbrake lever.

Guideline

Free travel at foot brake lever	3... 5 mm (0.12... 0.2 in)
---------------------------------	----------------------------

- Hold screw ③ and tighten nut ②.

Guideline

Remaining nuts, chassis	M8	30 Nm (22.1 lbf ft)
-------------------------	----	------------------------

- Hold push rod ⑤ and tighten nut ④.

Guideline

Remaining nuts, chassis	M6	15 Nm (11.1 lbf ft)
-------------------------	----	------------------------

- Reconnect spring ①.

Checking the rear brake fluid level

- Warning**
Danger of accidents Brake system failure.
- **MIN** If the brake fluid level falls below the MIN mark, this indicates a leakage in the brake system or worn-out brake linings. Have the brake system checked in an authorized KTM workshop, and do not ride any further.

- Warning**
Danger of accidents Reduced braking due to old brake fluid.
- Have the front and rear brake fluid replaced according to the service plan in an authorized KTM workshop.

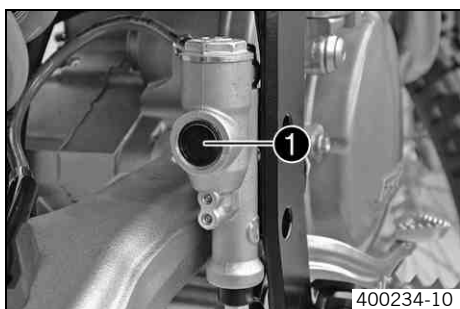

- Stand the vehicle upright.
- Check the brake fluid level in the viewer ①.
 - » When in the viewer ① an air bubble is visible:
 - Add brake fluid for the rear brake. 🛠️ (👉 p. 69)

Adding brake fluid for the rear brake 🛠️

- Warning**
Danger of accidents Brake system failure.
- **MIN** If the brake fluid level falls below the MIN mark, this indicates a leakage in the brake system or worn-out brake linings. Have the brake system checked in an authorized KTM workshop, and do not ride any further.

- Warning**
Skin irritations Brake fluid can cause skin irritation on contact.
- Avoid contact with skin and eyes, and keep out of the reach of children.
 - If brake fluid gets into your eyes, rinse thoroughly with water and contact a doctor immediately.

- Warning**
Danger of accidents Reduced braking due to old brake fluid.
- Have the front and rear brake fluid replaced according to the service plan in an authorized KTM workshop.

- Warning**
Environmental hazard Problem materials cause environmental damage.
- Dispose of oil, grease, filters, fuel, cleaning substances, brake fluid, batteries, etc. according to regulations.

- i** **Info**
- Never use DOT 5 brake fluid! This is based on silicone oil and is colored purple. Oil seals and brake lines are not designed for DOT 5 brake fluid.
Avoid contact between brake fluid and painted parts. Brake fluid attacks paint!
Use only clean brake fluid from a sealed container!

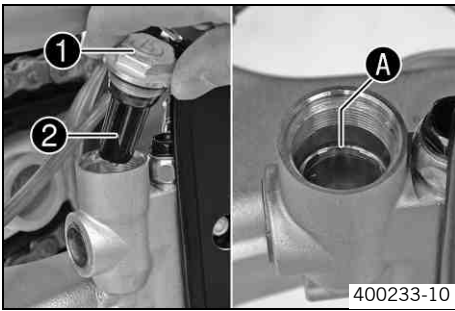

- Stand the vehicle upright.
- Remove screw cap ① with membrane ② and the O-ring.
- Add brake fluid to level A.

Brake fluid DOT 4 / DOT 5.1 (☛ p. 116)

- Mount the screw cap with the membrane and the O-ring.



Info

Clean up overflowed or spilt brake fluid immediately with water.

Checking the rear brake linings



Warning

Danger of accidents Reduced braking due to worn brake linings.

- Worn brake linings should be replaced immediately in an authorized KTM workshop.

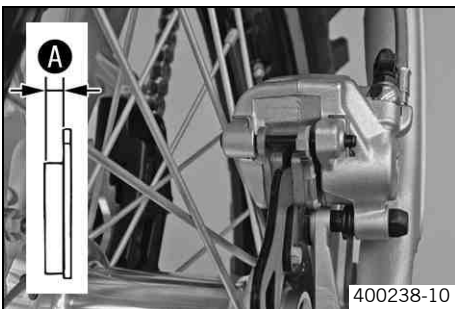

- Check the brake linings for minimum thickness A.

Minimum thickness A $\geq 1 \text{ mm } (\geq 0.04 \text{ in})$

- » If the minimum thickness is less than specified:
 - Change the rear brake linings. ☛ (☛ p. 71)

Removing rear brake linings ☛



Warning

Danger of accidents Improper brake maintenance and repair.

- Always have your brake system maintained and repaired in an authorized KTM workshop.

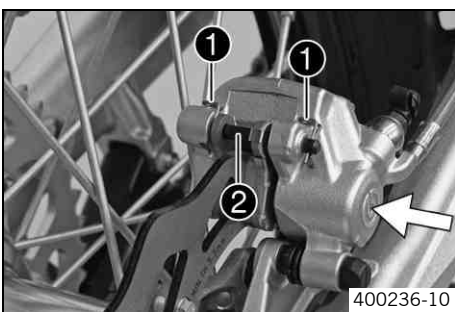

- Press the brake caliper by hand on to the brake disc in order to press back the brake piston.



Info

Make sure when pushing back the brake piston that you do not press the brake caliper against the spokes.

- Remove the locking split pins ①, withdraw the bolt ②, and take out the brake pads.
- Clean brake caliper and brake caliper support.

Installing the rear brake linings ☛



Warning

Danger of accidents Reduced braking due to oil or grease on the brake discs.

- Always keep the brake discs free of oil and grease, and clean them with brake cleaner when necessary.



Warning

Danger of accidents Reduced braking due to use of non-approved brake linings.

- Brake linings available from accessory suppliers are often not tested and approved for use on KTM vehicles. The construction and friction factor of the brake linings and therefore the brake power can differ considerably from the original KTM brake linings. If brake linings are used that differ from the originals, there is no guarantee that they comply with the original license. The vehicle no longer corresponds to the condition at delivery, and the warranty is no longer valid.

- Check the brake discs. (☛ p. 64)

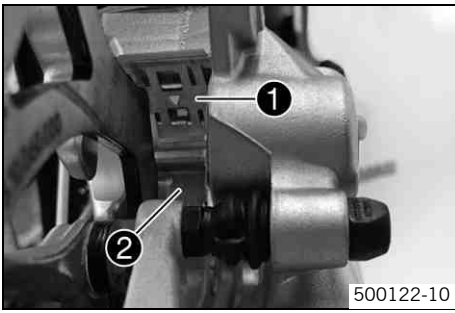

500122-10

- Check that leaf spring ❶ in the brake caliper and sliding plate ❷ in the brake caliper support are seated correctly.



Info

The arrow on the leaf spring points in the rotation direction of the brake disc.

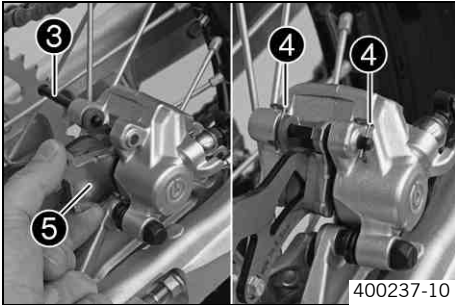

400237-10

- Fit the brake pads, insert bolt ❸, and mount locking split pins ❹.



Info

Make sure that the decoupling plate ❺ is mounted on the piston side of the brake pad.

- Operate the foot brake lever repeatedly until the brake linings lie on the brake disc and there is a tight spot.

Changing the rear brake linings 🛠️



Warning

Skin irritations Brake fluid can cause skin irritation on contact.

- Avoid contact with skin and eyes, and keep out of the reach of children.
- If brake fluid gets into your eyes, rinse thoroughly with water and contact a doctor immediately.



Warning

Danger of accidents Reduced braking due to old brake fluid.

- Have the front and rear brake fluid replaced according to the service plan in an authorized KTM workshop.



Warning

Environmental hazard Problem materials cause environmental damage.

- Dispose of oil, grease, filters, fuel, cleaning substances, brake fluid, batteries, etc. according to regulations.



Info

Never use DOT 5 brake fluid! This is based on silicone oil and is colored purple. Oil seals and brake lines are not designed for DOT 5 brake fluid.

Avoid contact between brake fluid and painted parts. Brake fluid attacks paint!

Use only clean brake fluid from a sealed container!

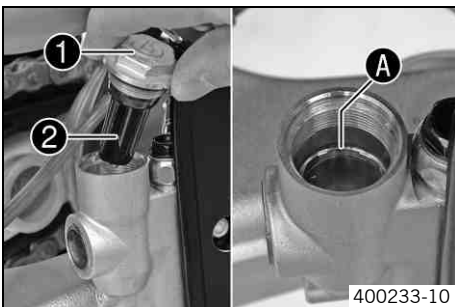

400233-10

- Remove the rear brake linings. 🛠️ (👉 p. 70)
- Stand the vehicle upright.
- Remove screw cap ❶ with membrane ❷ and the O-ring.
- Press the brake piston back to its basic position and make sure that no brake fluid overflows from the brake fluid reservoir.
- Install the rear brake linings. 🛠️ (👉 p. 70)
- Add brake fluid to level A.

Brake fluid DOT 4 / DOT 5.1 (👉 p. 116)

- Mount the screw cap with the membrane and the O-ring.



Info

Clean up overflowed or spilt brake fluid immediately with water.

Removing the front wheel ↩

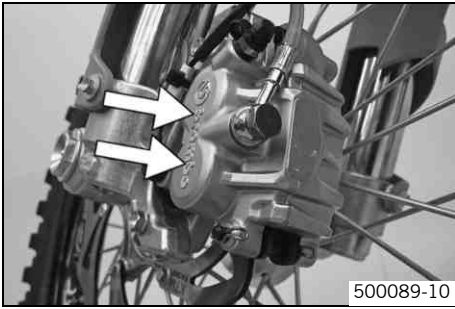

- Jack up the motorcycle. (↩ p. 37)
- Press the brake caliper by hand on to the brake disc in order to press back the brake pistons.

i Info

Make sure when pushing back the brake pistons that you do not press the brake caliper against the spokes.

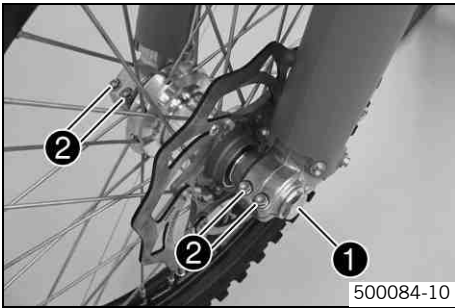

- Remove screw ❶.
- Loosen screw ❷.



- Holding the front wheel, withdraw the wheel spindle. Take the front wheel out of the fork.

i Info

Do not pull the hand brake lever when the front wheel is removed. Always lay the wheel down in such a way that the brake disc is not damaged.

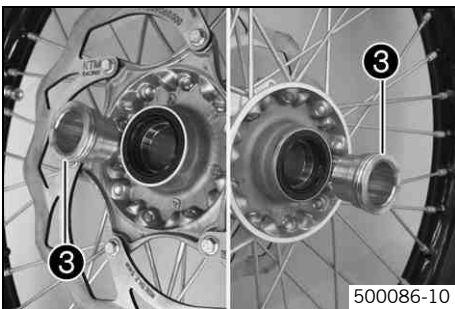

- Remove spacing sleeves ❸.

Installing the front wheel ↩



Warning

Danger of accidents Reduced braking due to oil or grease on the brake discs.

- Always keep the brake discs free of oil and grease, and clean them with brake cleaner when necessary.

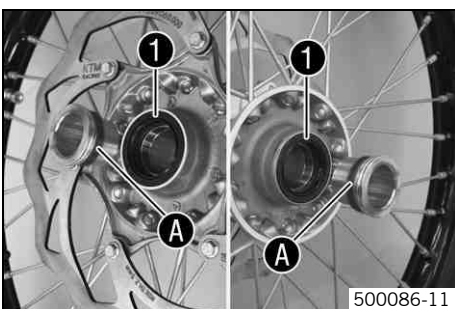

- Clean and grease shaft seal rings ❶ and bearing surface A of the spacing sleeves.
- Long-life grease (↩ p. 117)
- Insert the spacing sleeves.

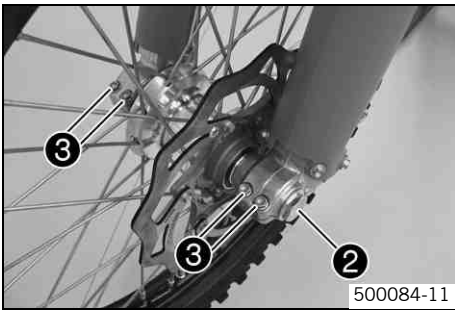

- Lift the front wheel into the fork, position it, and insert the wheel spindle.
- Mount and tighten screw ②.

Guideline

Screw, front wheel spindle	M24x1.5	45 Nm (33.2 lbf ft)
----------------------------	---------	------------------------

- Operate the hand brake lever several times until the brake pads are lying correctly on the brake disc.
- Remove the motorcycle from the work stand. (☛ p. 37)
- Pull the front wheel brake and push down hard on the fork several times to align the fork legs.
- Fully tighten screw ③.

Guideline

Screw, fork stub	M8	15 Nm (11.1 lbf ft)
------------------	----	------------------------

Removing rear wheel ☛

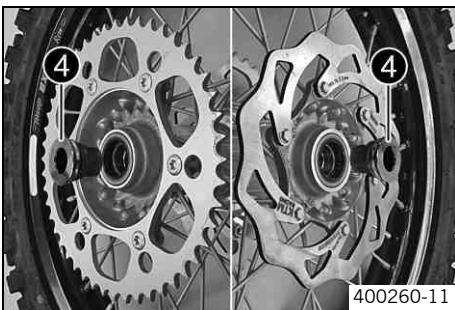
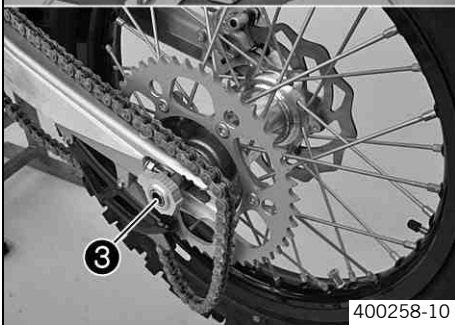
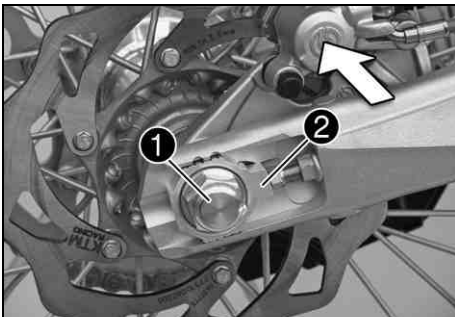

- Jack up the motorcycle. (☛ p. 37)
- Press the brake caliper by hand on to the brake disc in order to press back the brake piston.

i Info
Make sure when pushing back the brake piston that you do not press the brake caliper against the spokes.

- Remove nut ①.
- Remove chain adjuster ②. Withdraw the wheel spindle ③ only enough to allow the rear wheel to be pushed forward.
- Push the rear wheel forward as far as possible. Remove the chain from the rear sprocket.
- Holding the rear wheel, withdraw the wheel spindle. Take the rear wheel out of the swing arm.

i Info
Do not operate the foot brake when the rear wheel is removed.
Always lay the wheel down in such a way that the brake disc is not damaged.

- Remove the spacing sleeves ④.

Installing the rear wheel ☛

Warning
Danger of accidents Reduced braking due to oil or grease on the brake discs.

- Always keep the brake discs free of oil and grease, and clean them with brake cleaner when necessary.

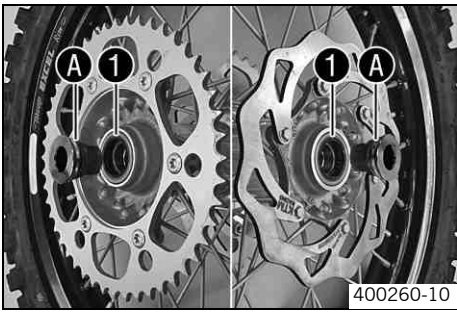

- Clean and grease shaft seal rings ① and bearing surface A of the spacing sleeves.

Long-life grease (☛ p. 117)

- Insert the spacing sleeves.

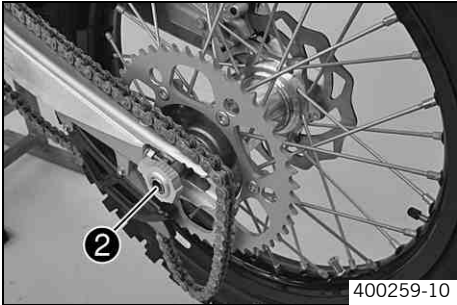

- Lift the rear wheel into the swing arm, position it, and insert the wheel spindle ②.
- Put the chain on.

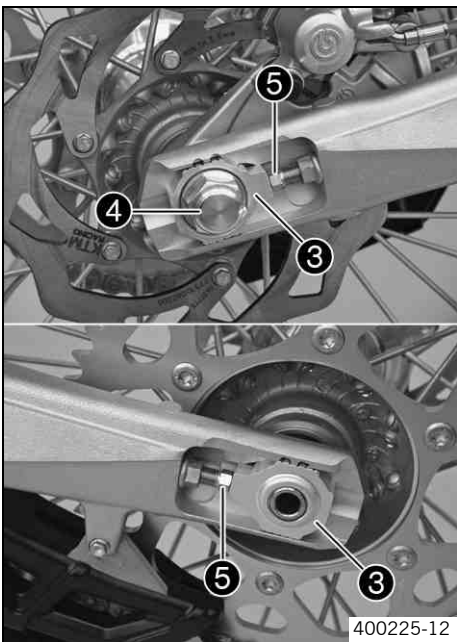

- Position the chain adjuster ③. Mount nut ④, but do not tighten it yet.
- Check the chain tension when fitting rear wheel. (☛ p. 58)
- Make sure that the chain adjusters ③ are fitted correctly on the adjusting screws ⑤.
- Tighten nut ④.

Guideline

Nut, rear wheel spindle	M20x1.5	80 Nm (59 lbf ft)
-------------------------	---------	-------------------

i Info

The wide adjustment range of the chain adjusters (32 mm) enables different secondary transmissions with the same chain length.
The chain adjusters ③ can be turned by 180°.

- Operate the foot brake lever repeatedly until the brake linings lie on the brake disc and there is a tight spot.
- Remove the motorcycle from the work stand. (☛ p. 37)

Tire condition checking

i Info

Only mount tires approved or recommended by KTM.
Other tires could have a negative effect on riding behavior.
The type, condition and air pressure of the tires all have an important impact on the riding behavior of the motorcycle.
The front and rear wheels must be mounted with tires with similar profiles.
Worn tires have a negative effect on riding behavior, especially on wet surfaces.

- Examine the front and rear tires for cuts, foreign bodies and other damage.
 - » If you find cuts, foreign bodies or other damage on a tire:
 - Change the tire.
- Check the depth of the tread.

i Info

Note local national regulations concerning the minimum tread depth.

Minimum tread depth	≥ 2 mm (≥ 0.08 in)
---------------------	--------------------

- » If the tread depth is less than the minimum allowable depth:
 - Change the tire.

Checking tire air pressure



Info

Low tire air pressure leads to abnormal wear and overheating of the tire. Correct tire air pressure ensures optimal riding comfort and maximum tire service life.



- Remove dust cap.
- Check tire air pressure when tires are cold.

Tire air pressure off road	
Front	1.0 bar (15 psi)
Rear	1.0 bar (15 psi)
Road tire pressure (EXC-F, EXC-F SIX DAYS)	
Front	1.5 bar (22 psi)
Rear	2.0 bar (29 psi)

- » If the tire pressure does not meet specifications:
 - Correct tire pressure.
- Mount dust cap.

Checking spoke tension



Warning

Danger of accidents Unstable riding behavior due to loose spokes.

- If you ride with loose spokes, the spokes can break. Have the spoke tension corrected in an authorized KTM workshop.



Info

A loose spoke can cause wheel imbalance, which leads to more loose spokes in a short time. If the spokes are too tight, they can break due to local overload. Check the spoke tension regularly, especially on a new motorcycle.



- To check spoke tension, tap each spoke with a screwdriver.

Guideline

You should hear a high note.		
Spoke nipple, front wheel	M4,5	5 Nm (3.7 lbf ft)
Spoke nipple, rear wheel	M5	5 Nm (3.7 lbf ft)



Info

If you hear different tone frequencies from different spokes, this is an indication of different spoke tensions.

Removing the battery ↘ (EXC-F, EXC-F SIX DAYS, XCF-W, XC-F)



Warning

Risk of injury Battery acid and battery gases cause serious chemical burns.

- Keep batteries out of the reach of children.
- Wear suitable protective clothing and goggles.
- Avoid contact with battery acid and battery gases.
- Keep the battery away from sparks or open fire. Charge only in well-ventilated rooms.
- In the event of skin contact, rinse with large amounts of water. If battery acid gets in the eyes, rinse with water for at least 15 minutes and contact a physician.

- Switch off all power consumers and switch off the engine.
- Remove the seat. (🔧 p. 77)

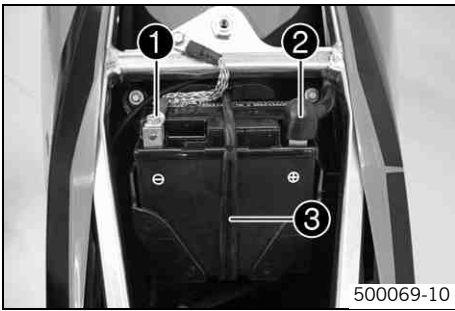

- Disconnect the negative (minus) cable ❶ of the battery.
- Pull back the plus pole cover ❷ and disconnect the positive (plus) cable of the battery.
- Hang the rubber band ❸ out to the bottom.
- Lift the battery up.

Installing the battery ↩ (EXC-F, EXC-F SIX DAYS, XCF-W, XC-F)

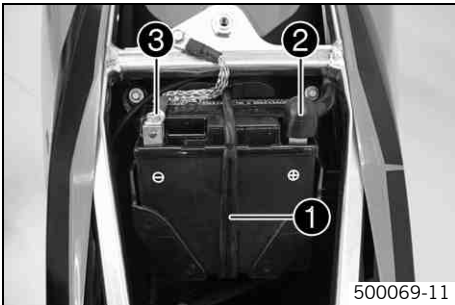

- Place the battery in the battery holder.

4Ah battery (YTX5L-BS) (☛ p. 99)

- Reconnect the rubber band ❶.
- Attach the plus cable and replace the plus pole cover ❷.
- Attach the minus cable ❸.
- Mount the seat. (☛ p. 78)

Recharging the battery ↩ (EXC-F, EXC-F SIX DAYS, XCF-W, XC-F)



Warning

Risk of injury Battery acid and battery gases cause serious chemical burns.

- Keep batteries out of the reach of children.
- Wear suitable protective clothing and goggles.
- Avoid contact with battery acid and battery gases.
- Keep the battery away from sparks or open fire. Charge only in well-ventilated rooms.
- In the event of skin contact, rinse with large amounts of water. If battery acid gets in the eyes, rinse with water for at least 15 minutes and contact a physician.



Warning

Environmental hazard Components and battery acid are a danger to the environment.

- Do not dispose of batteries in normal household waste. Take defective or used batteries to a battery recycling operator.



Warning

Environmental hazard Problem materials cause environmental damage.

- Dispose of oil, grease, filters, fuel, cleaning substances, brake fluid, batteries, etc. according to regulations.



Info

Even if there is no load on the battery, it loses power every day. The charge state and the type of charge are very important for the service life of the battery. Fast recharging with a high charge current shortens the battery's service life. If the charge current, the charge voltage and the charge time are exceeded, electrolyte escapes through the breathing holes. The battery capacity is then reduced. If the battery is discharged from starting, it must be recharged immediately. If it stands for a long time in a discharged state, the battery becomes over-discharged and sulfated, and then it is destroyed. The battery is maintenance-free, i.e., the acid level does not have to be checked.

- Switch off all power consumers and switch off the engine.
- Remove the seat. (☛ p. 77)
- Disconnect the minus (negative) cable of the battery to avoid damage to the motorcycle's electronics.

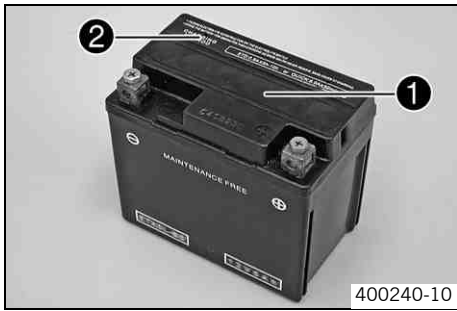

400240-10

- Connect the battery charger to the battery. Switch on the battery charger.

Battery charger (58429074000)

You can also use the battery charger to test rest potential and start potential of the battery, and to test the generator. With this device, you cannot overcharge the battery.



Info

Never remove the lid ❶.
Charge the battery with at most 10% of the capacity specified on the battery ❷.

- Switch off the charger after charging. Disconnect the battery.

Guideline

The charge current, charge voltage and charge time must not be exceeded.

Charge the battery regularly when the motorcycle is not in use.	3 months
---	----------

- Mount the seat. (☛ p. 78)

Removing a fuse (EXC-F, EXC-F SIX DAYS, XCF-W, XC-F)

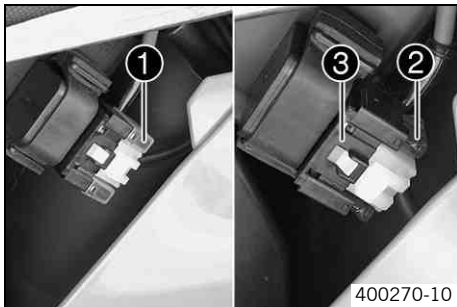

400270-10

- Switch off all power consumers and switch off the engine.
- Dismount the air filter box lid. (☛ p. 82)
- Remove the protection cover ❶.



Info

The fuse ❷ is located in the starter relay ❸ under the filter box cover.

- Remove the fuse ❷.

Replacing the fuse (EXC-F, EXC-F SIX DAYS, XCF-W, XC-F)



Warning

Fire hazard The electrical system can be overloaded by the use of incorrect fuses.

- Use only fuses with the prescribed amperage. Never by-pass or repair fuses.

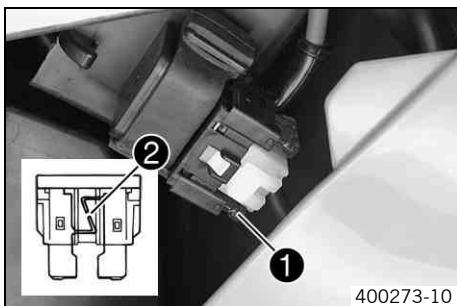

400273-10

- Refit the fuse.

Fuse (58011109110)



Info

A reserve fuse ❶ is located in the starter relay.
Replace a burned-out fuse ❷ only by an equivalent fuse.
If the new fuse burns out, contact an authorized KTM workshop.

- Replace the protection cover.
- Install the air filter box lid. (☛ p. 82)

Removing the seat

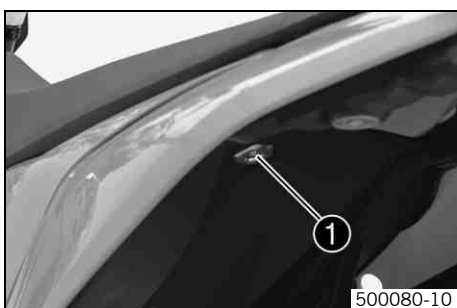

500080-10

- Remove screw ❶. Lift up the seat at the rear, pull it back and then remove from above.

Mounting the seat

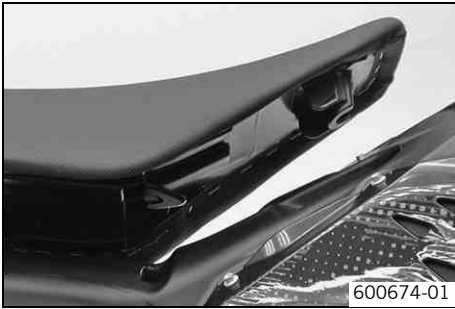

- Hook in the front of the seat at the collar sleeve of the fuel tank, lower it at the rear and simultaneously push it forward.
- Make sure that the seat is correctly locked in.
- Mount and tighten the screw of the seat fixing.

Guideline

Remaining screws, chassis	M6	10 Nm (7.4 lbf ft)
---------------------------	----	--------------------

Dismounting the fuel tank



Danger

Fire hazard Fuel can easily catch fire.

- Never fill up the vehicle near open flames or burning cigarettes, and always switch off the engine first. Be careful that no fuel is spilt, especially on hot vehicle components. Clean up spilt fuel immediately.
- Fuel in the fuel tank expands when warm and can escape if the tank is overfilled. See specifications on filling up with fuel.



Warning

Danger of poisoning Fuel is poisonous and a health hazard.

- Avoid contact between fuel and skin, eyes and clothing. Do not inhale fuel vapors. If fuel gets into your eyes, rinse immediately with water and contact a doctor. Wash affected skin areas immediately with soap and water. If fuel is swallowed, contact a doctor immediately. Change clothing that has come into contact with fuel. Store fuel in a suitable canister according to regulations and keep it out of the reach of children.

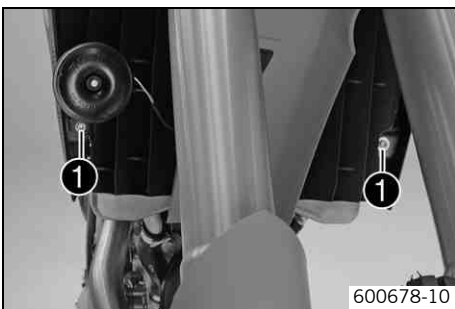

- Remove the seat. (☛ p. 77)

(EXC-F, EXC-F SIX DAYS, XCF-W, XC-F)

- Turn handle ❶ of the fuel tap to the **OFF** position. (Figure 500137-10☛ p. 22)

(SX-F)

- Turn handle ❶ of the fuel tap to the **OFF** position. (Figure 500178-10☛ p. 22)

- Pull off the fuel hose.



Info

Remaining fuel may flow out of the fuel hose.

- Remove screws ❶ with the collar sleeve.

(EXC-F, EXC-F SIX DAYS)

- Hang the horn and horn bracket to one side.

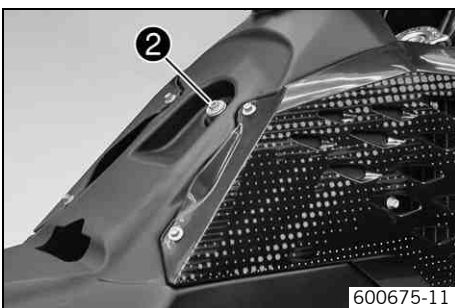

- Remove screw ❷ with the collar sleeve.

- Remove the tube from the fuel tank vent line.



- Pull both spoilers to the side of the radiator bracket ❸ and take the fuel tank away upward.

Installing the fuel tank ↶



Danger

Fire hazard Fuel can easily catch fire.

- Never fill up the vehicle near open flames or burning cigarettes, and always switch off the engine first. Be careful that no fuel is spilt, especially on hot vehicle components. Clean up spilt fuel immediately.
- Fuel in the fuel tank expands when warm and can escape if the tank is overfilled. See specifications on filling up with fuel.



Warning

Danger of poisoning Fuel is poisonous and a health hazard.

- Avoid contact between fuel and skin, eyes and clothing. Do not inhale fuel vapors. If fuel gets into your eyes, rinse immediately with water and contact a doctor. Wash affected skin areas immediately with soap and water. If fuel is swallowed, contact a doctor immediately. Change clothing that has come into contact with fuel.



- Position the fuel tank and install the two spoilers to the side of the radiator fixing.
- Make sure that no cables or Bowden cables are trapped or damaged.

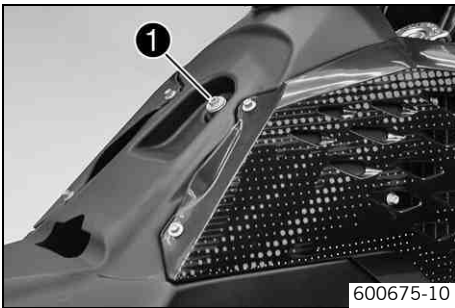

- Mount the fuel tank vent hose.
- Mount and tighten screw ❶ with the collar sleeve.

Guideline

Remaining screws, chassis	M6	10 Nm (7.4 lbf ft)
---------------------------	----	--------------------

(EXC-F, EXC-F SIX DAYS)

- Position the horn with the horn bracket.

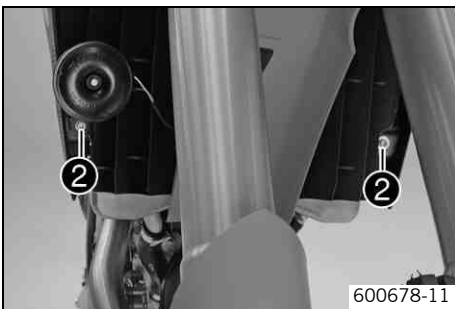

- Mount and tighten screws ❷ with the collar sleeve.

Guideline

Remaining screws, chassis	M6	10 Nm (7.4 lbf ft)
---------------------------	----	--------------------

- Connect the fuel hose.
- Mount the seat. (↶ p. 78)

Cooling system

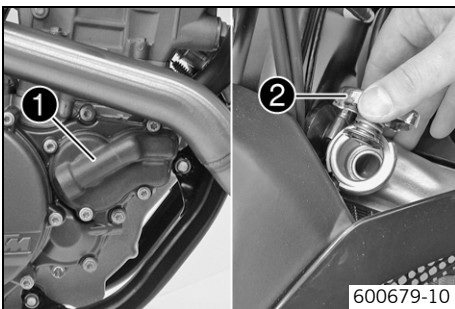

The water pump ❶ in the engine forces the coolant to flow.

The pressure resulting from the warming of the cooling system is regulated by a valve in the radiator cap ❷. The specified coolant temperature is therefore permissible without danger of function problems.

120 °C (248 °F)

Cooling is effected by the air stream.

The lower the speed, the less the cooling effect. Dirty cooling fins also reduce the cooling effect.

(250 EXC-F SIX DAYS EU, 250 XCF-W ZA)

The radiator fan provides extra cooling. It is controlled by a thermostwitch.

Checking antifreeze and coolant level

- Warning**
Danger of scalding The coolant gets very hot when the motorcycle is driven and is under high pressure.
- Do not open the radiator, radiator hoses or other cooling system components when the engine is hot. Allow the engine and cooling system to cool down. If you scald yourself, hold the affected area under cold water immediately.

- Warning**
Danger of poisoning Coolants are poisonous and a health hazard.
- Avoid contact between coolants and skin, eyes and clothing. If fuel gets into your eyes, rinse immediately with water and contact a doctor. Wash affected skin areas immediately with soap and water. If coolant is swallowed, contact a doctor immediately. Change clothes that have come into contact with coolants. Keep coolants out of the reach of children.

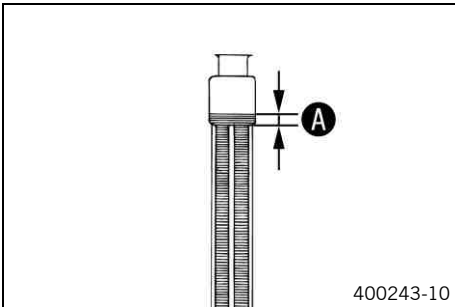

- Stand the motorcycle upright on a horizontal surface.
- Remove the radiator cap.
- Check antifreeze of coolant.

-25... -45 °C (-13... -49 °F)

- » If the antifreeze of the cooling liquid does not meet specifications:
 - Correct antifreeze of coolant.
- Check the coolant level in the radiator.

Coolant level A above radiator fins.	10 mm (0.39 in)
---	-----------------

- » If the level of the cooling liquid does not meet specifications:
 - Correct the coolant level.

Alternative 1

Coolant (☛ p. 116)

Alternative 2

Coolant (mixed ready to use) (☛ p. 116)

- Refit the radiator cap.

Checking the coolant level

- Warning**
Danger of scalding The coolant gets very hot when the motorcycle is driven and is under high pressure.
- Do not open the radiator, radiator hoses or other cooling system components when the engine is hot. Allow the engine and cooling system to cool down. If you scald yourself, hold the affected area under cold water immediately.

- Warning**
Danger of poisoning Coolants are poisonous and a health hazard.
- Avoid contact between coolants and skin, eyes and clothing. If fuel gets into your eyes, rinse immediately with water and contact a doctor. Wash affected skin areas immediately with soap and water. If coolant is swallowed, contact a doctor immediately. Change clothes that have come into contact with coolants. Keep coolants out of the reach of children.

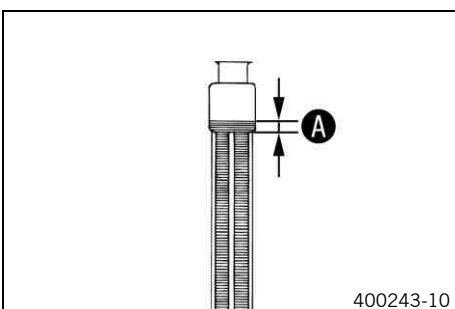

- Stand the motorcycle upright on a horizontal surface.
- Remove the radiator cap.
- Check the coolant level in the radiator.

Coolant level A above radiator fins.	10 mm (0.39 in)
---	-----------------

- » If the level of the cooling liquid does not meet specifications:
 - Correct the coolant level.

Alternative 1

Coolant (☛ p. 116)

Alternative 2

Coolant (mixed ready to use) (☛ p. 116)

- Refit the radiator cap.

Draining the coolant

- Warning**
Danger of scalding The coolant gets very hot when the motorcycle is driven and is under high pressure.
- Do not open the radiator, radiator hoses or other cooling system components when the engine is hot. Allow the engine and cooling system to cool down. If you scald yourself, hold the affected area under cold water immediately.

- Warning**
Danger of poisoning Coolants are poisonous and a health hazard.
- Avoid contact between coolants and skin, eyes and clothing. If fuel gets into your eyes, rinse immediately with water and contact a doctor. Wash affected skin areas immediately with soap and water. If coolant is swallowed, contact a doctor immediately. Change clothes that have come into contact with coolants. Keep coolants out of the reach of children.

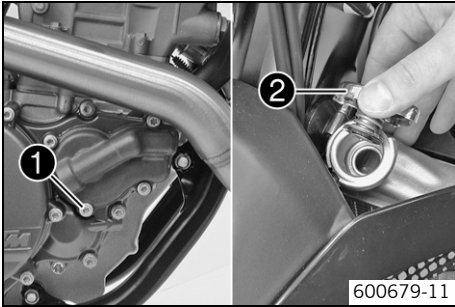

- Stand the vehicle upright.
- Place a suitable container under the water pump cover.
- Remove screw 1. Remove radiator cap 2.
- Completely drain the coolant.
- Mount screw 1 with a new seal and tighten it.

Guideline

Screw, water pump cover	M6	10 Nm (7.4 lbf ft)
-------------------------	----	--------------------

Refilling coolant

- Warning**
Danger of poisoning Coolants are poisonous and a health hazard.
- Avoid contact between coolants and skin, eyes and clothing. If fuel gets into your eyes, rinse immediately with water and contact a doctor. Wash affected skin areas immediately with soap and water. If coolant is swallowed, contact a doctor immediately. Change clothes that have come into contact with coolants. Keep coolants out of the reach of children.

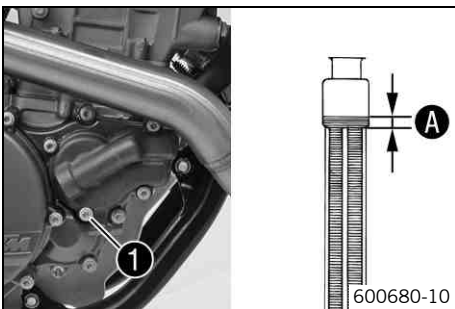

- Make sure that the screw 1 is tightened.
- Stand the vehicle upright.
- Pour coolant in up to measurement A above the radiator fins.

Guideline

10 mm (0.39 in)		
Coolant	1.2 l (1.3 qt.)	Coolant (☛ p. 116)
		Coolant (mixed ready to use) (☛ p. 116)

- Refit the radiator cap.
- Make a short test ride.
- Check the coolant level. (☛ p. 80)

Glass fiber yarn filling of main silencer

The main silencer is filled with glass fiber yarn. Over a period, the fibers of the insulating material vanish into the air, and the silencer "burns out". Not only is the noise level higher, the performance characteristic changes.

Removing main silencer

Warning
Danger of burns The exhaust system gets very hot when the vehicle is driven.

- Allow the exhaust system to cool down. Do not touch hot components.

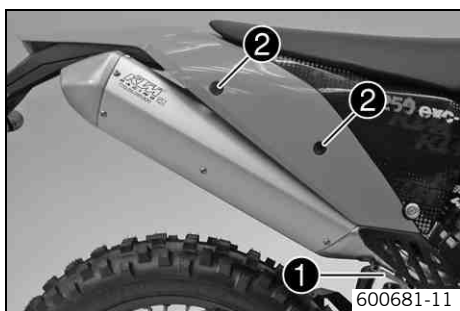

- Disconnect spring ❶.
- Remove screws ❷ and take off main silencer.

Installing the main silencer

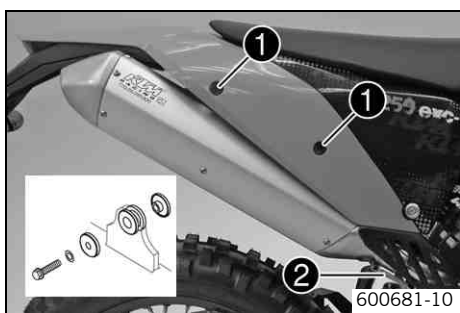

- Mount the main silencer. Mount and tighten screws ❶.

Guideline

Remaining screws, chassis	M6	10 Nm (7.4 lbf ft)
---------------------------	----	--------------------

- Reconnect spring ❷.

Dismounting the air filter box lid



- Pull off the air filter box lid in area ❶ to the side and remove to the front.

Installing the air filter box lid

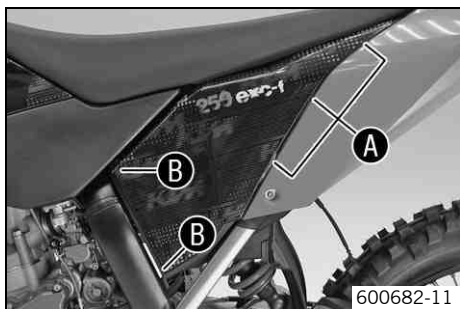

- Insert the air filter box lid into the rear area ❶ and clip it into the front area ❷.

Removing the air filter ↩

Note

Engine failure Unfiltered intake air has a negative effect on the service life of the engine.

- Never ride the vehicle without an air filter since dust and dirt can get into the engine and result in increased wear.



Warning

Environmental hazard Problem materials cause environmental damage.

- Dispose of oil, grease, filters, fuel, cleaning substances, brake fluid, batteries, etc. according to regulations.

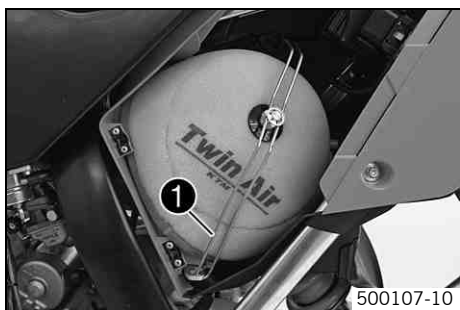

- Dismount the air filter box lid. (↩ p. 82)
- Hang the air filter holder ❶ out to the bottom and swing it to the side. Remove the air filter with the air filter support.
- Remove the air filter from the air filter support.

Installing the air filter ↩

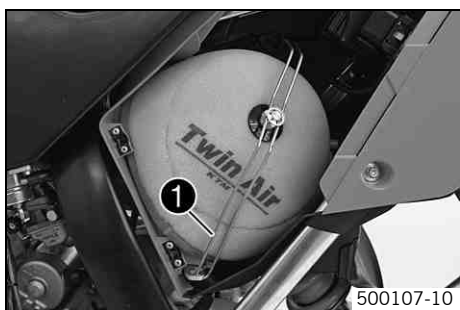

- Mount the clean air filter onto the air filter support.
- Put in both parts together, position them and fix them with the air filter support ❶.



Info

If the air filter is not correctly mounted, dust and dirt can penetrate into the engine and can cause damage.

- Install the air filter box lid. (↩ p. 82)

Cleaning air filter ↩



Warning

Environmental hazard Problem materials cause environmental damage.

- Dispose of oil, grease, filters, fuel, cleaning substances, brake fluid, batteries, etc. according to regulations.



Info

Do not clean the air filter with fuel or petroleum since these substances attack the foam.

- Remove the air filter. ↩ (↩ p. 83)
- Wash the air filter thoroughly in special cleaning liquid and allow it to dry properly.

Air filter cleaner (↩ p. 117)



Info

Only press the air filter to dry it, never wring it out.

- Oil the dry air filter with a high/quality filter oil.

Oil for foam air filter (↩ p. 118)

- Clean the air filter box.
- Check carburetor connection boot for damage and tightness.
- Install the air filter. ↩ (↩ p. 83)

Carburetor - idle

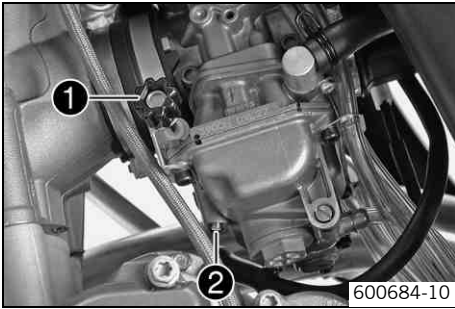

The idle setting of the carburetor has a big influence on the starting behavior, stable idling and the response to throttle opening. That means that an engine with a correctly set idle speed is easier to start than if the idle is set wrongly.

i Info

The carburetor and its components are subject to increased wear caused by engine vibration. Wear can result in malfunctioning.

The idle speed is adjusted with the adjustment screw ❶.
The idle mixture is adjusted with the idle mixture adjustment screw ❷.

Carburetor - adjusting idle ↩

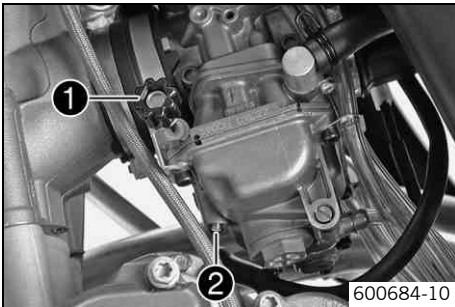

- Screw in the idle adjusting screw ❷ until it stops and then to the prescribed basic setting.

Guideline

Idle mixture adjusting screw (EXC-F, EXC-F SIX DAYS, SX-F)	
Open	1.25 turns
Idle mixture adjusting screw (250 XCF-W ZA, 250 XC-F USA)	
Open	1.0 turn
Idle mixture adjusting screw (250 XCF-W USA)	
Open	1.5 turns

Adjustment tool for mixture control screw (77329034000)

- Run the engine until warm.

Guideline

Warm-up time	≥ 5 min
--------------	---------



Danger

Danger of poisoning Exhaust gases are poisonous and can result in unconsciousness and/or death.

- When running the engine, always make sure there is sufficient ventilation, and do not start or run the engine in a closed space.

- Adjust the idle speed with adjusting screw ❶.

Guideline

Choke function deactivated – The choke lever is pushed in to the stop. (EXC-F AUS, XCF-W, XC-F, SX-F) (☛ p. 23)	
Choke function deactivated – The choke lever is pushed back to the stop. (EXC-F EU, EXC-F SIX DAYS) (☛ p. 23)	
Idle speed	1,400... 1,500 rpm

- Turn the idle adjusting screw ❷ slowly until the idle speed begins to fall.
- Note the position and turn the idle adjusting screw slowly counterclockwise until the idle speed falls.
- Adjust to the point between these two positions with the highest idle speed.

i Info

If there is a big engine speed rise, reduce the idle speed to a normal level and repeat the above steps.

The extreme sport motorcyclist will set the mixture about ¼ of a turn back from this ideal value (leaner, in a clockwise direction) since the engine becomes hotter in sporting use.

If the procedure described here does not lead to satisfactory results, the cause may be a wrongly dimensioned idling jet.

If you can turn the idle adjusting screw to the end without any change of engine speed, you have to mount a smaller idling jet.

The idle adjusting screw must not be opened more than two turns. If more than two turns are necessary (rich mixture), use a larger idling jet.

After changing the idling jet, start from the beginning with the adjusting steps.

- Adjust the idle speed with adjusting screw ❶.

Guideline

Choke function deactivated – The choke lever is pushed in to the stop. (EXC-F AUS, XCF-W, XC-F, SX-F) (☛ p. 23)	
Choke function deactivated – The choke lever is pushed back to the stop. (EXC-F EU, EXC-F SIX DAYS) (☛ p. 23)	
Idle speed	1,400... 1,500 rpm

i Info
Following extreme air temperature or altitude changes, adjust the idle speed again.

Emptying the carburetor float chamber ☞

⚠ Danger
Fire hazard Fuel can easily catch fire.

- Never fill up the vehicle near open flames or burning cigarettes, and always switch off the engine first. Be careful that no fuel is spilt, especially on hot vehicle components. Clean up spilt fuel immediately.
- Fuel in the fuel tank expands when warm and can escape if the tank is overfilled. See specifications on filling up with fuel.

⚠ Warning
Danger of poisoning Fuel is poisonous and a health hazard.

- Avoid contact between fuel and skin, eyes and clothing. Do not inhale fuel vapors. If fuel gets into your eyes, rinse immediately with water and contact a doctor. Wash affected skin areas immediately with soap and water. If fuel is swallowed, contact a doctor immediately. Change clothing that has come into contact with fuel. Store fuel in a suitable canister according to regulations and keep it out of the reach of children.

🌿 Warning
Environmental hazard Improper handling of fuel is a danger to the environment.

- Do not allow fuel to get into the ground water, the ground, or the sewage system.

i Info
Carry out this work with a cold engine.

(EXC-F, EXC-F SIX DAYS, XCF-W, XC-F)

- Turn handle ❶ of the fuel tap to the **OFF** position. (Figure 500137-10☛ p. 22)

(SX-F)

- Turn handle ❶ of the fuel tap to the **OFF** position. (Figure 500178-10☛ p. 22)

✓ No more fuel flows from the tank to the carburetor.

- Guide the hose coming down behind the engine into a suitable container.

i Info
Water in the float chamber results in malfunctioning.

- Undo screw ❶ (turn it counterclockwise) a few turns and drain the fuel from the float chamber.
- Tighten screw ❶.

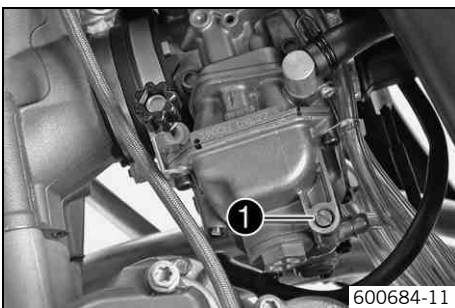

Checking the engine oil level

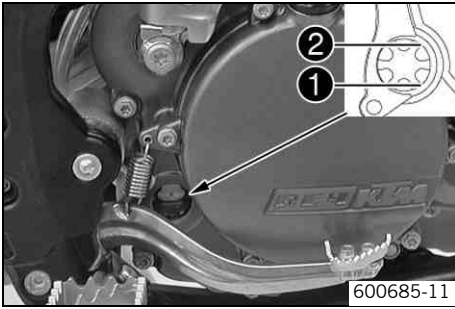

- Stand the motorcycle upright on a horizontal surface.

Condition

The engine is cold.

- Check the engine oil level.

The engine oil level is at the bottom edge of level viewer ❶.

- » If the engine oil level is below the specified level:
 - Add engine oil. (☛ p. 89)

Condition

The engine is warm.

- Check the engine oil level.

The engine oil level is at the top edge of level viewer ❷.

- » If the engine oil level is below the specified level:
 - Add engine oil. (☛ p. 89)

Changing the engine oil and oil filter, cleaning the oil screen ☛

- Drain the engine oil. ☛ (☛ p. 86)
- Clean the oil screens. ☛ (☛ p. 87)
- Remove the oil filter. ☛ (☛ p. 88)
- Install the oil filter. ☛ (☛ p. 88)
- Fill up with engine oil. ☛ (☛ p. 89)

Draining the engine oil ☛



Warning

Danger of scalding Engine oil and gear oil get very hot when the motorcycle is driven.

- Wear suitable protective clothing and gloves. If you scald yourself, hold the affected area under cold water immediately.



Warning

Environmental hazard Problem materials cause environmental damage.

- Dispose of oil, grease, filters, fuel, cleaning substances, brake fluid, batteries, etc. according to regulations.



Info

Drain the engine oil only when the engine is warm.

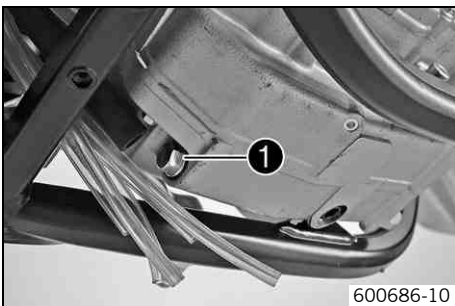

- Stand the motorcycle on its side stand on a horizontal surface.
- Place a suitable container under the engine.
- Remove oil drain plug ❶.
- Completely drain the engine oil.
- Thoroughly clean the oil drain plug with the magnet.
- Clean the sealing area on the engine.
- Mount and tighten oil drain plug ❶ with the seal ring.

Guideline

Oil drain plug with magnet	M12x1.5	20 Nm (14.8 lbf ft)
----------------------------	---------	------------------------

Cleaning the oil screens



Warning

Danger of scalding Engine oil and gear oil get very hot when the motorcycle is driven.

- Wear suitable protective clothing and gloves. If you scald yourself, hold the affected area under cold water immediately.



Warning

Environmental hazard Problem materials cause environmental damage.

- Dispose of oil, grease, filters, fuel, cleaning substances, brake fluid, batteries, etc. according to regulations.

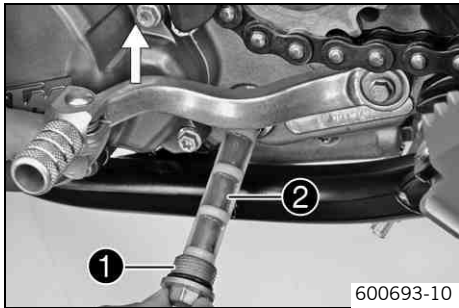

- Place a suitable container under the engine.
- Remove plug 1 with oil screen 2 and the O-rings.

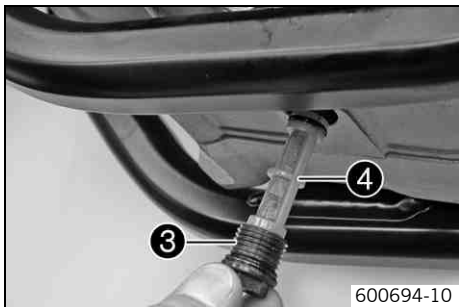

- Remove plug 3 with oil screen 4 and the O-rings.
- Drain the remaining engine oil.
- Thoroughly clean parts and sealing area.

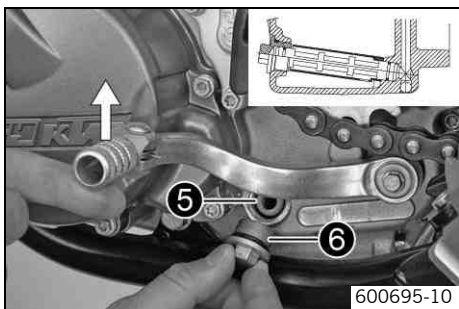

- Position oil screen 5 with the O-rings.
- Mount and tighten plug 6 with the O-ring.

Guideline

Plug for oil screen, long	M20x1.5	15 Nm (11.1 lbf ft)
---------------------------	---------	------------------------

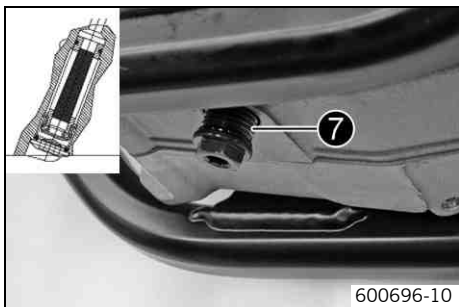

- Position the oil screen with the O-rings.
- Mount and tighten plug 7 with the O-ring.

Guideline

Plug for oil screen, short	M16x1.5	10 Nm (7.4 lbf ft)	lubricated with engine oil
----------------------------	---------	-----------------------	----------------------------

Removing the oil filter ↩

- Warning**
Danger of scalding Engine oil and gear oil get very hot when the motorcycle is driven.
- Wear suitable protective clothing and gloves. If you scald yourself, hold the affected area under cold water immediately.

- Warning**
Environmental hazard Problem materials cause environmental damage.
- Dispose of oil, grease, filters, fuel, cleaning substances, brake fluid, batteries, etc. according to regulations.

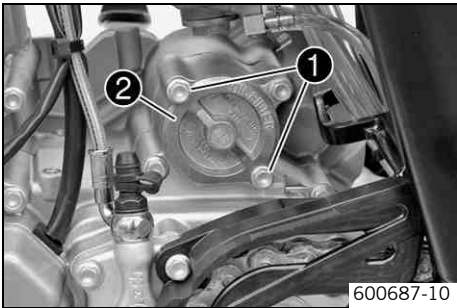

600687-10

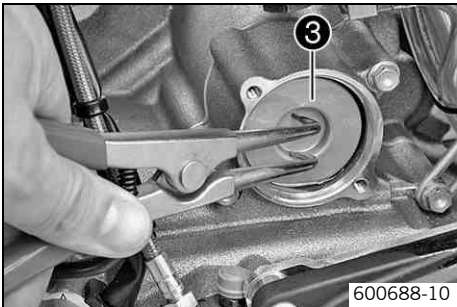

600688-10

- Place a suitable container under the engine.
- Remove screws ①. Remove oil filter cover ② with O-ring.

- Pull the oil filter insert ③ out of the oil filter casing.

Circlip pliers reverse (51012011000)

- Completely drain the engine oil.
- Thoroughly clean parts and sealing area.

Installing the oil filter ↩

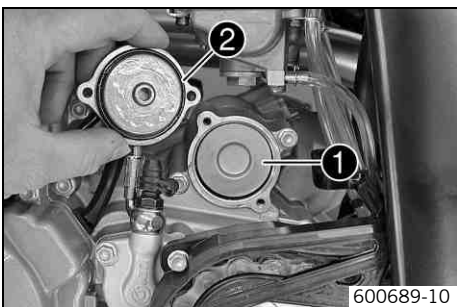

600689-10

- Lay the motorcycle on its side and fill the oil filter housing to about 1/3 full with engine oil.
- Fill oil filter ① with engine oil and place it in the oil filter container.
- Lubricate O-ring ② of the oil filter cover.

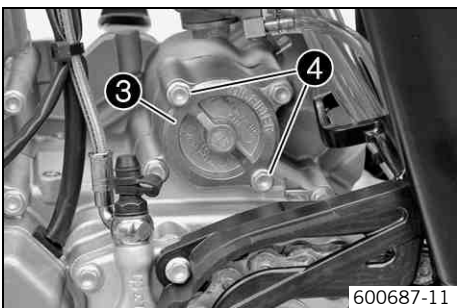

600687-11

- Mount oil filter cover ③.
- Mount and tighten screws ④.

Guideline

Screw, oil filter cover	M5	6 Nm (4.4 lbf ft)
-------------------------	----	-------------------

- Stand the motorcycle up.

Filling up with engine oil



Info

Too little engine oil or poor-quality engine oil results in premature wear to the engine.

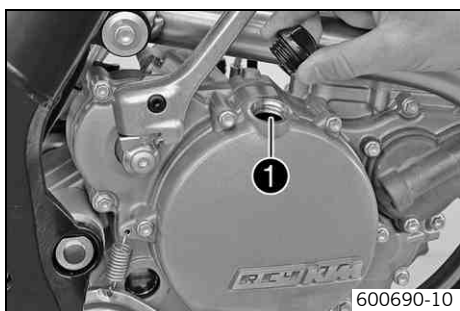

- Remove screw connection ❶ on the clutch cover and fill up with engine oil.

Engine oil	1.10 l (1.16 qt.)	Engine oil (SAE 10W/50) (☛ p. 116)
------------	-------------------	------------------------------------

- Mount and tighten screw cap ❶.



Danger

Danger of poisoning Exhaust gases are poisonous and can result in unconsciousness and/or death.

- When running the engine, always make sure there is sufficient ventilation, and do not start or run the engine in a closed space.

- Start the engine and check that it is oil-tight.
- Check the engine oil level. (☛ p. 86)

Adding engine oil



Info

Too little engine oil or poor-quality engine oil results in premature wear to the engine.

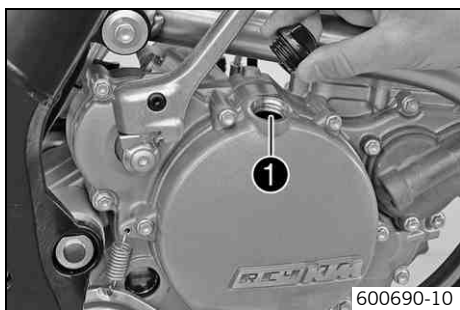

- Remove screw cap ❶ from the clutch cover and fill up with engine oil.

Engine oil (SAE 10W/50) (☛ p. 116)

- Mount and tighten screw cap ❶.



Danger

Danger of poisoning Exhaust gases are poisonous and can result in unconsciousness and/or death.

- When running the engine, always make sure there is sufficient ventilation, and do not start or run the engine in a closed space.

- Start the engine and check that it is oil-tight.
- Check the engine oil level. (☛ p. 86)

Faults	Possible cause	Action
The engine cannot be cranked (electric starter). EXC-F, EXC-F SIX DAYS, XCF-W, XC-F	Operating error	– Go through the steps of starting the engine. (☛ p. 28)
	Battery discharged	– Recharge the battery. ☛ (☛ p. 76) – Check the charging voltage. ☛ – Check the closed current. ☛ – Check the generator. ☛
	Fuse blown	– Remove the fuse. (☛ p. 77) – Replace the fuse. (☛ p. 77)
	Starter relay defective	– Check the starter relay. ☛
	Starter motor defective	– Check the starter motor. ☛
Engine turns but does not start.	Operating error	– Go through the steps of starting the engine. (☛ p. 28)
	Motorcycle was out of use for a long time and there is old fuel in the float chamber	– Empty the carburetor float chamber. ☛ (☛ p. 85)
	Fuel feed interrupted	– Check the fuel tank breather. – Clean the fuel tap. – Check/adjust the carburetor components. ☛
	Engine flooded	– Clean and dry the spark plug or replace if necessary.
	Spark plug oily or wet	– Clean and dry the spark plug or replace if necessary.
	Electrode distance (plug gap) of spark plug too wide	– Adjust the plug gap. Guideline Spark plug electrode gap 0.7 mm (0.028 in)
	Defect in ignition system	– Check the ignition system. ☛
	Short-circuit cable in cable harness frayed, short-circuit button or emergency OFF switch defective	– Check the wiring harness (visual check). – Check the electrical system.
	Plug connector of CDI control device, pulse generator or ignition coil oxidized.	– Clean the plug connector and treat it with contact spray.
	Water in carburetor or jets blocked	– Check/adjust the carburetor components. ☛
Engine has no idle.	Idling jet blocked	– Check/adjust the carburetor components. ☛
	Adjusting screws on carburetor distorted	– Carburetor - adjust the idle speed. ☛ (☛ p. 84)
	Spark plug defective	– Change spark plug.
	Ignition system defective	– Check the ignition coil. ☛ – Check the CDI unit. ☛ – Check the spark plug connector. ☛ – Check the ignition pulse generator. ☛ – Check the generator. ☛
Engine does not speed up.	Carburetor running over because float needle dirty or worn.	– Check/adjust the carburetor components. ☛
	Loose carburetor jets	– Check/adjust the carburetor components. ☛
	Ignition system defective	– Check the ignition coil. ☛ – Check the CDI unit. ☛ – Check the spark plug connector. ☛ – Check the ignition pulse generator. ☛ – Check the generator. ☛

Faults	Possible cause	Action
Engine has too little power.	Fuel feed interrupted	<ul style="list-style-type: none"> - Check the fuel tank breather. - Clean the fuel tap. - Check/adjust the carburetor components. 🛠️
	Air filter very dirty	<ul style="list-style-type: none"> - Clean the air filter. 🛠️ (📄 p. 83)
	Exhaust system leaky, deformed or too little glass fiber yarn filling in main silencer	<ul style="list-style-type: none"> - Check exhaust system for damage. - Change glass fiber yarn filling of main silencer. 🛠️
	Valve clearance too little	<ul style="list-style-type: none"> - Adjust the valve clearance. 🛠️
	Ignition system defective	<ul style="list-style-type: none"> - Check the ignition coil. 🛠️ - Check the CDI unit. 🛠️ - Check the spark plug connector. 🛠️ - Check the ignition pulse generator. 🛠️ - Check the generator. 🛠️
Engine stalls or is popping into the carburetor	Lack of fuel	<p>(EXC-F, EXC-F SIX DAYS, XCF-W, XC-F)</p> <ul style="list-style-type: none"> - Turn handle ❶ of the fuel tap to the ON position. (Figure 500137-10 📄 p. 22) <p>(SX-F)</p> <ul style="list-style-type: none"> - Turn handle ❶ of the fuel tap to the ON position. (Figure 500178-10 📄 p. 22) - Fill up with fuel. (📄 p. 30)
	Engine takes in bad air	<ul style="list-style-type: none"> - Check rubber sleeves and carburetor for tightness.
Engine overheats.	Too little coolant in cooling system	<ul style="list-style-type: none"> - Check the cooling system for leakage. - Check the coolant level. (📄 p. 80)
	Too little air stream	<ul style="list-style-type: none"> - Switch off engine when standing.
	Radiator fins very dirty	<ul style="list-style-type: none"> - Clean radiator fins.
	Foam formation in cooling system	<ul style="list-style-type: none"> - Drain the coolant. 🛠️ (📄 p. 81) - Refill the coolant. 🛠️ (📄 p. 81)
	Bent radiator hose	<ul style="list-style-type: none"> - Change the radiator hose. 🛠️
	Thermostat defective	<ul style="list-style-type: none"> - Check the thermostat. 🛠️ <p>Guideline Opening temperature: 70 °C (158 °F)</p>
	Defect in radiator fan system (250 EXC-F SIX DAYS EU, 250 XCF-W ZA)	<ul style="list-style-type: none"> - Check the radiator fan fuse. - Check the radiator fan. 🛠️ - Check the thermostat. 🛠️
High oil consumption	Engine vent hose bent	<ul style="list-style-type: none"> - Route the vent hose without bends or replace it if necessary.
	Engine oil level too high	<ul style="list-style-type: none"> - Check the engine oil level. (📄 p. 86)
	Engine oil too thin (low viscosity)	<ul style="list-style-type: none"> - Change the engine oil and oil filter, clean the oil screen. 🛠️ (📄 p. 86)
	Piston or cylinder is worn	<ul style="list-style-type: none"> - Piston/cylinder - determine the mounting clearance 🛠️
Battery discharged	The battery does not charge	<ul style="list-style-type: none"> - Check the charging voltage. 🛠️ - Check the charging current. 🛠️ - Check the generator. 🛠️
	Undesired power consumer	<ul style="list-style-type: none"> - Check the closed current. 🛠️
Speedometer values deleted (time, stop watch, lap times)	The battery in the speedometer is empty.	<ul style="list-style-type: none"> - Change the battery in the speedometer.

Cleaning motorcycle

Note

Material damage Damage and destruction of components by high-pressure cleaning equipment.

- Never clean the vehicle with high-pressure cleaning equipment or a strong water-jet. The excessive pressure can penetrate electrical components, connects, Bowden cables, and bearings, etc., and can damage or destroy these parts.

Warning



Environmental hazard Problem materials cause environmental damage.

- Dispose of oil, grease, filters, fuel, cleaning substances, brake fluid, batteries, etc. according to regulations.

Info

If you clean the motorcycle regularly, its value and appearance are maintained over a long period. Avoid direct sunshine on the motorcycle during cleaning.

- Before you clean the motorcycle, seal the exhaust system to prevent penetration by water.
- First remove coarse dirt particles with a gentle water spray.
- Spray very dirty areas with a normal motorcycle cleaner and then clean with a paintbrush.

Motorcycle cleaner (☛ p. 117)

Info

Use warm water containing normal motorcycle cleaner and a soft sponge.

- After rinsing the motorcycle with a gentle water spray, allow it to dry thoroughly.
- Empty the carburetor float chamber. 🛠️ (☛ p. 85)

Warning



Danger of accidents Reduced braking due to wet or dirty brakes.

- Clean or dry dirty or wet brakes by riding and braking gently.

- After cleaning, ride the vehicle a short distance until the engine warms up, and then apply the brakes.

Info

The heat produced causes water at inaccessible positions in the engine and the brakes to evaporate.

- Push back the protection covers on the handlebar instruments to allow water to evaporate.
- After the motorcycle has cooled off, oil or grease all moving parts and bearings.
- Clean the chain. (☛ p. 57)
- Treat bare metal parts (except for brake discs and exhaust system) with anti-corrosion materials.

Cleaning and polishing materials for metal, rubber and plastic (☛ p. 117)

- Treat all painted parts with a mild paint polish.

High-luster polish for paint (☛ p. 117)

- To prevent electrical problems, treat electric contacts and switches with contact spray.

Contact spray (☛ p. 117)

(EXC-F, EXC-F SIX DAYS)

- Lubricate the steering lock.

Universal oil spray (☛ p. 118)

Storage



Warning

Danger of poisoning Fuel is poisonous and a health hazard.

- Avoid contact between fuel and skin, eyes and clothing. Do not inhale fuel vapors. If fuel gets into your eyes, rinse immediately with water and contact a doctor. Wash affected skin areas immediately with soap and water. If fuel is swallowed, contact a doctor immediately. Change clothing that has come into contact with fuel. Store fuel in a suitable canister according to regulations and keep it out of the reach of children.



Info

If you want to garage the motorcycle for a longer period, take the following actions.

Before storing the motorcycle, check all parts for function and wear. If service, repairs or replacements are necessary, you should do this during the storage period (less workshop overload). In this way, you can avoid long workshop waiting times at the start of the new season.

- Clean the motorcycle. (🔧 p. 92)
- Change the engine oil and oil filter, clean the oil screen. 🛠️ (🔧 p. 86)
- Check the antifreeze and coolant level. (🔧 p. 80)
- Drain the fuel from the tank into a suitable container.
- Empty the carburetor float chamber. 🛠️ (🔧 p. 85)
- Check the tire air pressure. (🔧 p. 75)

(EXC-F, EXC-F SIX DAYS, XCF-W, XC-F)

- Remove the battery. 🛠️ (🔧 p. 75)

(EXC-F, EXC-F SIX DAYS, XCF-W, XC-F)

- Recharge the battery. 🛠️ (🔧 p. 76)

Guideline

Storage temperature of battery without direct sunlight.	0... 35 °C (32... 95 °F)
---	--------------------------

- The storage place should be dry and not subject to large temperature fluctuations.



Info

KTM recommends jacking up the motorcycle.

- Jack up the motorcycle. (🔧 p. 37)
- Cover the motorcycle with a porous sheet or blanket. Do not use non-porous materials since they prevent humidity from escaping, thus causing corrosion.



Info

Avoid running the engine for a short time only. Since the engine cannot warm up properly, the water vapor produced during combustion condenses and causes valves and exhaust system to rust.

Putting into operation after storage

- Remove the motorcycle from the work stand. (🔧 p. 37)

(EXC-F, EXC-F SIX DAYS, XCF-W, XC-F)

- Install the battery. 🛠️ (🔧 p. 76)
- Fill up with fuel. (🔧 p. 30)
- Checks before putting into operation (🔧 p. 28)
- Make a test ride.

Design	1-cylinder 4-stroke engine, water-cooled
Displacement	248.60 cm ³ (15.1706 cu in)
Stroke	54.80 mm (2.1575 in)
Bore	76 mm (2.99 in)
Compression ratio	12.8:1
Idle speed	1,400... 1,500 rpm
Control	DOHC, four valves controlled via cam lever, drive via tooth-wheel chain
Valve diameter, intake	30.0 mm (1.181 in)
Valve diameter, exhaust	26.0 mm (1.024 in)
Valve clearance	
Exhaust at: 20 °C (68 °F)	0.12... 0.17 mm (0.0047... 0.0067 in)
Intake at: 20 °C (68 °F)	0.10... 0.15 mm (0.0039... 0.0059 in)
Crankshaft bearing	2 cylinder bearings
Conrod bearing	Needle bearing
Piston pin bearing	Bronze bush
Pistons	Forged light alloy
Piston rings	1 compression ring, 1 oil scraper ring
Engine lubrication	Pressure circulation lubrication with two rotary pumps
Primary transmission	22:68
Clutch	Multidisc clutch in oil bath/hydraulically activated
Transmission ratio (EXC-F, EXC-F SIX DAYS, XCF-W)	
1st gear	13:33
2nd gear	17:33
3rd gear	19:29
4th gear	23:28
5th gear	23:23
6th gear	26:22
Transmission ratio (SX-F, 250 XC-F USA)	
1st gear	13:32
2nd gear	15:30
3rd gear	17:28
4th gear	19:26
5th gear	21:25
6th gear	22:24
Generator (EXC-F, EXC-F SIX DAYS, XCF-W, XC-F)	
Light coil and charging coil	12 V, 80 W
Generator (SX-F)	
Light coil and charging coil	none
Ignition	Contactless controlled fully electronic ignition with digital ignition adjustment, type Kokusan
Spark plug	NGK CR 9 EKB
Spark plug electrode gap	0.7 mm (0.028 in)
Cooling	Water cooling, permanent circulation of coolant by water pump
Starting aid (EXC-F, EXC-F SIX DAYS, XCF-W, XC-F)	Electric starter/kickstarter
Starting aid (SX-F)	Kickstarter

Capacity- engine oil

Engine oil	1.10 l (1.16 qt.)	Engine oil (SAE 10W/50) (☛ p. 116)
------------	-------------------	------------------------------------

Capacity - coolant

Coolant	1.2 l (1.3 qt.)	Coolant (☛ p. 116)
		Coolant (mixed ready to use) (☛ p. 116)

Oil jet, conrod lubrication	M4		Loctite® 243™
Oil jet for cam lever lubrication	M5	4 Nm (3 lbf ft)	Loctite® 243™
Screw, locking lever	M5	6 Nm (4.4 lbf ft)	Loctite® 243™
Screw, freewheel hub	M5	7 Nm (5.2 lbf ft)	Loctite® 243™
Screw, ignition pulse generator	M5	6 Nm (4.4 lbf ft)	Loctite® 243™
Screw, stator bracket (SX-F)	M5	6 Nm (4.4 lbf ft)	Loctite® 243™
Screw, oil filter cover	M5	6 Nm (4.4 lbf ft)	–
Screw, oil pump cover	M5	6 Nm (4.4 lbf ft)	Loctite® 243™
Oil jet, piston cooling	M6x0.75	4 Nm (3 lbf ft)	Loctite® 243™
Screw, cover plate of valve cover	M6	3 Nm (2.2 lbf ft)	Loctite® 243™
Screw, kickstarter stop	M6	10 Nm (7.4 lbf ft)	Loctite® 243™
Screw, timing chain securing guide	M6	10 Nm (7.4 lbf ft)	Loctite® 243™
Screw, exhaust flange	M6	10 Nm (7.4 lbf ft)	Loctite® 243™
Screw, starter motor (EXC-F, EXC-F SIX DAYS, XCF-W, XC-F)	M6	10 Nm (7.4 lbf ft)	–
Screw, generator cover	M6	10 Nm (7.4 lbf ft)	–
Screw, cable holder in generator cover	M6	6 Nm (4.4 lbf ft)	Loctite® 243™
Screw, clutch cover	M6	10 Nm (7.4 lbf ft)	–
Screw, clutch spring	M6	10 Nm (7.4 lbf ft)	–
Screw, clutch slave cylinder	M6	10 Nm (7.4 lbf ft)	–
Locking screw for bearing	M6	6 Nm (4.4 lbf ft)	Loctite® 243™
Screw, engine housing	M6	10 Nm (7.4 lbf ft)	–
Screw, shift drum locating	M6	10 Nm (7.4 lbf ft)	Loctite® 243™
Screw, shift lever	M6	10 Nm (7.4 lbf ft)	Loctite® 243™
Screw, timing chain tensioning rail	M6	10 Nm (7.4 lbf ft)	Loctite® 243™
Screw, stator bracket (EXC-F, EXC-F SIX DAYS, XCF-W, XC-F)	M6	8 Nm (5.9 lbf ft)	Loctite® 243™
Screw, valve cover	M6	10 Nm (7.4 lbf ft)	–
Screw, water pump cover	M6	10 Nm (7.4 lbf ft)	–
Screw, cylinder head	M6	10 Nm (7.4 lbf ft)	–
Nut, camshaft bearing bridge	M7	15 Nm (11.1 lbf ft)	lubricated with engine oil
Screw, camshaft bearing bridge	M7	15 Nm (11.1 lbf ft)	lubricated with engine oil
Stud, camshaft bearing bridge	M7		Loctite® 243™
Screw, kickstarter	M8	25 Nm (18.4 lbf ft)	Loctite® 243™
Screw, timing chain guide rail	M8	10 Nm (7.4 lbf ft)	Loctite® 243™
Plug, crankshaft location	M8	20 Nm (14.8 lbf ft)	–
Screw, unlocking of timing chain tensioner	M10x1	10 Nm (7.4 lbf ft)	–
Screw, engine sprocket	M10	60 Nm (44.3 lbf ft)	Loctite® 243™
Screw, cylinder head	M10	Tightening sequence: Tighten diagonally, beginning with the rear screw on the chain shaft. Step 1 40 Nm (29.5 lbf ft) Step 2 50 Nm (36.9 lbf ft)	lubricated with engine oil
Spark plug	M10	10... 12 Nm (7.4... 8.9 lbf ft)	–
Nut, rotor	M12x1	60 Nm (44.3 lbf ft)	–
Screw, camshaft gear	M12x1	80 Nm (59 lbf ft)	Loctite® 243™
Plug, oil pressure regulator valve	M12x1.5	20 Nm (14.8 lbf ft)	–
Oil drain plug with magnet	M12x1.5	20 Nm (14.8 lbf ft)	–
Plug for oil screen, short	M16x1.5	10 Nm (7.4 lbf ft)	lubricated with engine oil

Nut, inner clutch hub	M18x1.5	120 Nm (88.5 lbf ft)	Loctite® 243™
Nut, primary gear	M18LHx1.5	150 Nm (110.6 lbf ft)	Loctite® 243™
Plug for oil screen, long	M20x1.5	15 Nm (11.1 lbf ft)	–
Plug, timing chain tensioner	M24x1.5	25 Nm (18.4 lbf ft)	–

EXC-F, EXC-F SIX DAYS

Carburetor type	KEIHIN FCR-MX 39
Carburetor identification number	3900H
Needle position	3rd position from top
Idle mixture adjusting screw	
Open	1.25 turns
Pump membrane stop	2.15 mm (0.0846 in)
Main jet	168
Jet needle	OBDIS (OBETP)
Idling jet	42
Idle air jet	100
Cold start jet	65 (85)
Leakage nozzle	70
Slide stop	present

XCF-W, 250 XCF USA

Carburetor type	KEIHIN FCR-MX 39
Carburetor identification number	3900K
Needle position (250 XCF-W USA)	3rd position from top
Needle position (250 XCF-W ZA, 250 XC-F USA)	5th position from top
Idle mixture adjusting screw (250 XCF-W ZA, 250 XC-F USA)	
Open	1.0 turn
Idle mixture adjusting screw (250 XCF-W USA)	
Open	1.5 turns
Pump membrane stop	2.15 mm (0.0846 in)
Main jet	168
Jet needle (250 XCF-W USA)	OBEKT
Jet needle (250 XCF-W ZA, 250 XC-F USA)	OBETP
Idling jet	42
Idle air jet	100
Cold start jet	85
Leakage nozzle	50

SX-F

Carburetor type	KEIHIN FCR-MX 39
Carburetor identification number	3925I
Needle position	4th position from top
Idle mixture adjusting screw	
Open	1.25 turns
Pump membrane stop	2.15 mm (0.0846 in)
Main jet	175
Jet needle	OBEKP
Idling jet	40
Idle air jet	100
Cold start jet	85
Leakage nozzle	50

Frame	Central tube frame made of chrome molybdenum steel tubing	
Fork (EXC-F, EXC-F SIX DAYS, XCF-W)	WP Suspension 4860 MXMA PA	
Fork (250 XC-F USA)	WP Suspension 4860 MXMA CC	
Fork (250 SX-F EU)	WP Suspension 4860 MXMA CC	
Fork (250 SX-F USA)	WP Suspension 4860 MXMA CC	
Suspension travel		
Front	300 mm (11.81 in)	
Rear	335 mm (13.19 in)	
Fork offset (XCF-W USA, XC-F, SX-F)		
Front marking	18 mm (0.71 in)	
Rear marking	20 mm (0.79 in)	
Fork offset (250 EXC-F SIX DAYS EU)	19 mm (0.75 in)	
Fork offset (EXC-F EU, EXC-F AUS, XCF-W ZA)	20 mm (0.79 in)	
Shock absorber	WP Suspension PDS 5018 DCC	
Brake system	Disc brakes, brake calipers on floating bearings	
Diameter of brake discs		
Front	260 mm (10.24 in)	
Rear	220 mm (8.66 in)	
Wear limit of brake discs		
Front	2.5 mm (0.098 in)	
Rear	3.5 mm (0.138 in)	
Tire air pressure off road		
Front	1.0 bar (15 psi)	
Rear	1.0 bar (15 psi)	
Road tire pressure (EXC-F, EXC-F SIX DAYS)		
Front	1.5 bar (22 psi)	
Rear	2.0 bar (29 psi)	
Final drive (EXC-F, EXC-F SIX DAYS)	14:38 (13:50)	
Final drive (XCF-W)	13:52	
Final drive (SX-F, 250 XC-F USA)	13:48	
Chain	5/8 x 1/4"	
Rear sprockets available	38, 40, 42, 45, 48, 49, 50, 51, 52	
Steering head angle	63.5°	
Wheelbase	1,475±10 mm (58.07±0.39 in)	
Seat height unloaded	985 mm (38.78 in)	
Ground clearance unloaded	380 mm (14.96 in)	
Weight without fuel, approx. (EXC-F, EXC-F SIX DAYS)	105.7 kg (233 lb.)	
Weight without fuel, approx. (250 XCF-W ZA)	102.6 kg (226.2 lb.)	
Weight without fuel, approx. (250 XCF-W USA, 250 XC-F USA)	101.6 kg (224 lb.)	
Weight without fuel, approx. (SX-F)	98 kg (216 lb.)	
Maximum permissible front axle load	145 kg (320 lb.)	
Maximum permissible rear axle load	190 kg (419 lb.)	
Maximum permissible overall weight	335 kg (739 lb.)	
4Ah battery (EXC-F, EXC-F SIX DAYS, XCF-W, XC-F)	YTX5L-BS	Battery voltage: 12 V Nominal capacity: 4 Ah maintenance-free

Lighting equipment

Headlight (EXC-F, EXC-F SIX DAYS, XCF-W ZA)	BA20d	12 V 35/35 W
Parking light (EXC-F, EXC-F SIX DAYS, XCF-W ZA)	W2,1x9,5d	12 V 5 W
Indicator lights (EXC-F, EXC-F SIX DAYS)	W2x4,6d	12 V 1.2 W
Flasher light (EXC-F, EXC-F SIX DAYS)	BA15s	12 V 10 W
Brake/tail light (EXC-F, EXC-F SIX DAYS, XCF-W ZA)	LED	
License plate lamp (EXC-F, EXC-F SIX DAYS)	W2,1x9,5d	12 V 5 W

Tires

Validity	Front tire	Rear tire
(EXC-F, EXC-F SIX DAYS)	90/90 - 21 M/C 54M M+S TT Metzeler MEC 6 DAYS EXTREME	120/90 - 18 M/C 65M M+S TT Metzeler MEC 6 DAYS EXTREME
(XCF-W, 250 XC-F USA)	80/100 - 21 51M TT Bridgestone Bridgestone M59	100/100 - 18 64M TT Bridgestone Bridgestone M402
(SX-F)	80/100 - 21 51M TT Bridgestone Bridgestone M59	100/90 - 19 62M TT Bridgestone Bridgestone M70

For further information, see the Service section under:
<http://www.ktm.com>

Capacity - fuel

Total fuel tank capacity, approx. (EXC-F, EXC-F SIX DAYS, XCF-W, XC-F)	9.2 l (2.43 US gal)	Super unleaded (ROZ 95 / RON 95 / PON 91) (☛ p. 116)
Total fuel tank capacity, approx. (SX-F)	8.0 l (2.11 US gal)	Super unleaded (ROZ 95 / RON 95 / PON 91) (☛ p. 116)
Fuel reserve, approx. (EXC-F, EXC-F SIX DAYS, XCF-W, XC-F)	2 l (2 qt.)	

EXC-F, EXC-F SIX DAYS, XCF-W

Fork part number	14.18.7E.04
Fork	WP Suspension 4860 MXMA PA
Compression damping	
Comfort	26 clicks
Standard	22 clicks
Sport	20 clicks
Rebound damping	
Comfort	24 clicks
Standard	22 clicks
Sport	22 clicks
Spring preload - Preload Adjuster	
Comfort	0 turn
Standard	1 turn
Sport	3 turns
Spring length with preload spacer(s)	510 mm (20.08 in)
Spring rate	
Weight of rider: 65... 75 kg (143... 165 lb.)	4.0 N/mm (22.8 lb/in)
Weight of rider: 75... 85 kg (165... 187 lb.)	4.2 N/mm (24 lb/in)
Weight of rider: 85... 95 kg (187... 209 lb.)	4.4 N/mm (25.1 lb/in)
Fork length	940 mm (37.01 in)
Air chamber length	110 ⁺²⁰ ₋₃₀ mm (4.33 ^{+0.79} _{-1.18} in)
FORK OIL	Fork oil (SAE 5) (☛ p. 116)

250 XC-F USA

Fork part number	14.18.7E.28	
Fork	WP Suspension 4860 MXMA CC	
Compression damping		
Comfort	17 clicks	
Standard	15 clicks	
Sport	13 clicks	
Rebound damping		
Comfort	22 clicks	
Standard	21 clicks	
Sport	21 clicks	
Spring length with preload spacer(s)	492 mm (19.37 in)	
Spring rate		
Weight of rider: 65... 75 kg (143... 165 lb.)	4.2 N/mm (24 lb/in)	
Weight of rider: 75... 85 kg (165... 187 lb.)	4.4 N/mm (25.1 lb/in)	
Weight of rider: 85... 95 kg (187... 209 lb.)	4.6 N/mm (26.3 lb/in)	
Fork length	940 mm (37.01 in)	
Gas pressure	1.2 bar (17 psi)	
Oil capacity / cartridge	195 ml (6.59 fl. oz.)	Fork oil (SAE 5) (☛ p. 116)
Oil capacity / fork tube without cartridge	365 ml (12.34 fl. oz.)	Fork oil (SAE 5) (☛ p. 116)

250 SX-F EU

Fork part number	14.18.7E.03	
Fork	WP Suspension 4860 MXMA CC	
Compression damping		
Comfort	14 clicks	
Standard	12 clicks	
Sport	10 clicks	
Rebound damping		
Comfort	21 clicks	
Standard	20 clicks	
Sport	20 clicks	
Spring length with preload spacer(s)	492 mm (19.37 in)	
Spring rate		
Weight of rider: 65... 75 kg (143... 165 lb.)	4.2 N/mm (24 lb/in)	
Weight of rider: 75... 85 kg (165... 187 lb.)	4.4 N/mm (25.1 lb/in)	
Weight of rider: 85... 95 kg (187... 209 lb.)	4.6 N/mm (26.3 lb/in)	
Fork length	940 mm (37.01 in)	
Gas pressure	1.2 bar (17 psi)	
Oil capacity / cartridge	195 ml (6.59 fl. oz.)	Fork oil (SAE 5) (☛ p. 116)
Oil capacity / fork tube without cartridge	360 ml (12.17 fl. oz.)	Fork oil (SAE 5) (☛ p. 116)

250 SX-F USA

Fork part number	14.18.7E.22	
Fork	WP Suspension 4860 MXMA CC	
Compression damping		
Comfort	17 clicks	
Standard	15 clicks	
Sport	13 clicks	
Rebound damping		
Comfort	22 clicks	
Standard	22 clicks	
Sport	20 clicks	
Spring length with preload spacer(s)	492 mm (19.37 in)	
Spring rate		
Weight of rider: 65... 75 kg (143... 165 lb.)	4.4 N/mm (25.1 lb/in)	
Weight of rider: 75... 85 kg (165... 187 lb.)	4.6 N/mm (26.3 lb/in)	
Weight of rider: 85... 95 kg (187... 209 lb.)	4.8 N/mm (27.4 lb/in)	
Fork length	940 mm (37.01 in)	
Gas pressure	1.2 bar (17 psi)	
Oil capacity / cartridge	195 ml (6.59 fl. oz.)	Fork oil (SAE 5) (☛ p. 116)
Oil capacity / fork tube without cartridge	375 ml (12.68 fl. oz.)	Fork oil (SAE 5) (☛ p. 116)

EXC-F, EXC-F SIX DAYS, XCF-W

Shock absorber part number	12.18.7E.04
Shock absorber	WP Suspension PDS 5018 DCC
Compression damping, low-speed	
Comfort	18 clicks
Standard	15 clicks
Sport	12 clicks
Compression damping, high-speed	
Comfort	2 turns
Standard	1.5 turns
Sport	1 turn
Rebound damping	
Comfort	26 clicks
Standard	24 clicks
Sport	22 clicks
Spring preload	9 mm (0.35 in)
Spring rate	
Weight of rider: 65... 75 kg (143... 165 lb.)	66 N/mm (377 lb/in)
Weight of rider: 75... 85 kg (165... 187 lb.)	69 N/mm (394 lb/in)
Weight of rider: 85... 95 kg (187... 209 lb.)	72 N/mm (411 lb/in)
Spring length	250 mm (9.84 in)
Gas pressure	10 bar (145 psi)
Static sag	35 mm (1.38 in)
Riding sag	105 mm (4.13 in)
Fitted length	411 mm (16.18 in)

250 XC-F USA

Shock absorber part number	12.18.7E.28
Shock absorber	WP Suspension PDS 5018 DCC
Compression damping, low-speed	
Comfort	17 clicks
Standard	15 clicks
Sport	13 clicks
Compression damping, high-speed	
Comfort	1 turn
Standard	1 turn
Sport	3/4 turn
Rebound damping	
Comfort	25 clicks
Standard	25 clicks
Sport	23 clicks
Spring preload	5 mm (0.2 in)
Spring rate	
Weight of rider: 65... 75 kg (143... 165 lb.)	66 N/mm (377 lb/in)
Weight of rider: 75... 85 kg (165... 187 lb.)	69 N/mm (394 lb/in)
Weight of rider: 85... 95 kg (187... 209 lb.)	72 N/mm (411 lb/in)
Spring length	250 mm (9.84 in)
Gas pressure	10 bar (145 psi)
Static sag	33 mm (1.3 in)
Riding sag	112 mm (4.41 in)
Fitted length	411 mm (16.18 in)

250 SX-F EU

Shock absorber part number	12.18.7E.03
Shock absorber	WP Suspension PDS 5018 DCC
Compression damping, low-speed	
Comfort	17 clicks
Standard	15 clicks
Sport	13 clicks
Compression damping, high-speed	
Comfort	1.5 turns
Standard	1.5 turns
Sport	1 turn
Rebound damping	
Comfort	24 clicks
Standard	22 clicks
Sport	21 clicks
Spring preload	6 mm (0.24 in)
Spring rate	
Weight of rider: 65... 75 kg (143... 165 lb.)	66 N/mm (377 lb/in)
Weight of rider: 75... 85 kg (165... 187 lb.)	69 N/mm (394 lb/in)
Weight of rider: 85... 95 kg (187... 209 lb.)	72 N/mm (411 lb/in)
Spring length	250 mm (9.84 in)
Gas pressure	10 bar (145 psi)
Static sag	33 mm (1.3 in)
Riding sag	105 mm (4.13 in)
Fitted length	411 mm (16.18 in)

250 SX-F USA

Shock absorber part number	12.18.7E.22
Shock absorber	WP Suspension PDS 5018 DCC
Compression damping, low-speed	
Comfort	17 clicks
Standard	15 clicks
Sport	13 clicks
Compression damping, high-speed	
Comfort	1 turn
Standard	1 turn
Sport	3/4 turn
Rebound damping	
Comfort	25 clicks
Standard	24 clicks
Sport	22 clicks
Spring preload	7 mm (0.28 in)
Spring rate	
Weight of rider: 65... 75 kg (143... 165 lb.)	66 N/mm (377 lb/in)
Weight of rider: 75... 85 kg (165... 187 lb.)	69 N/mm (394 lb/in)
Weight of rider: 85... 95 kg (187... 209 lb.)	72 N/mm (411 lb/in)
Spring length	250 mm (9.84 in)
Gas pressure	10 bar (145 psi)
Static sag	33 mm (1.3 in)
Riding sag	107 mm (4.21 in)
Fitted length	411 mm (16.18 in)

Spoke nipple, front wheel	M4,5	5 Nm (3.7 lbf ft)	–
Spoke nipple, rear wheel	M5	5 Nm (3.7 lbf ft)	–
Screw, spoiler on fuel tank (250 XCF-W USA, 250 XC-F USA)	M5x12	1.5 Nm (1.11 lbf ft)	–
Remaining nuts, chassis	M6	15 Nm (11.1 lbf ft)	–
Remaining screws, chassis	M6	10 Nm (7.4 lbf ft)	–
Screw, rear brake disc	M6	14 Nm (10.3 lbf ft)	–
Screw, front brake disc	M6	14 Nm (10.3 lbf ft)	–
Screw, shock absorber adjusting ring	M6	5 Nm (3.7 lbf ft)	–
Screw, ball joint of push rod on foot-brake cylinder	M6	10 Nm (7.4 lbf ft)	–
Nut, rear sprocket screw	M8	35 Nm (25.8 lbf ft)	Loctite® 243™
Nut, rim lock	M8	10 Nm (7.4 lbf ft)	–
Remaining nuts, chassis	M8	30 Nm (22.1 lbf ft)	–
Remaining screws, chassis	M8	25 Nm (18.4 lbf ft)	–
Screw, front brake caliper	M8	25 Nm (18.4 lbf ft)	Loctite® 243™
Screw, top triple clamp (EXC-F SIX DAYS, XCF-W USA, XC-F, SX-F)	M8	17 Nm (12.5 lbf ft)	–
Screw, top triple clamp (EXC-F EU, EXC-F AUS, XCF-W ZA)	M8	20 Nm (14.8 lbf ft)	–
Screw, bottom triple clamp (EXC-F SIX DAYS, XCF-W USA, XC-F, SX-F)	M8	12 Nm (8.9 lbf ft)	–
Screw, bottom triple clamp (EXC-F EU, EXC-F AUS, XCF-W ZA)	M8	15 Nm (11.1 lbf ft)	–
Screw, fork stub	M8	15 Nm (11.1 lbf ft)	–
Screw, top steering stem (EXC-F SIX DAYS, XCF-W USA, XC-F, SX-F)	M8	17 Nm (12.5 lbf ft)	Loctite® 243™
Screw, top steering stem (EXC-F EU, EXC-F AUS, XCF-W ZA)	M8	20 Nm (14.8 lbf ft)	–
Screw, handlebar clamp (EXC-F EU, EXC-F AUS, XCF-W, XC-F, SX-F)	M8	20 Nm (14.8 lbf ft)	–
Screw, handlebar clamp (250 EXC-F SIX DAYS EU)	M8	16 Nm (11.8 lbf ft)	–
Screw, engine brace	M8	33 Nm (24.3 lbf ft)	–
Screw, subframe	M8	35 Nm (25.8 lbf ft)	Loctite® 243™
Screw, side stand fixing	M8	40 Nm (29.5 lbf ft)	Loctite® 243™
Engine carrying screw	M10	60 Nm (44.3 lbf ft)	–
Remaining nuts, chassis	M10	50 Nm (36.9 lbf ft)	–
Remaining screws, chassis	M10	45 Nm (33.2 lbf ft)	–
Screw, handlebar support	M10	40 Nm (29.5 lbf ft)	Loctite® 243™
Nut, seat fixing	M12x1	20 Nm (14.8 lbf ft)	–
Screw, top shock absorber	M12	80 Nm (59 lbf ft)	Loctite® 243™
Screw, bottom shock absorber	M12	80 Nm (59 lbf ft)	Loctite® 243™
Nut, swingarm pivot	M16x1.5	100 Nm (73.8 lbf ft)	–
Screw-in nozzles, cooling system	M20x1.5	12 Nm (8.9 lbf ft)	Loctite® 243™
Nut, rear wheel spindle	M20x1.5	80 Nm (59 lbf ft)	–
Screw, top steering head	M20x1.5	10 Nm (7.4 lbf ft)	–
Screw, bottom steering head (XCF-W USA, XC-F, SX-F)	M20x1.5	60 Nm (44.3 lbf ft)	Loctite® 243™
Screw, front wheel spindle	M24x1.5	45 Nm (33.2 lbf ft)	–

Wiring diagram (EXC-F EU, EXC-F SIX DAYS)

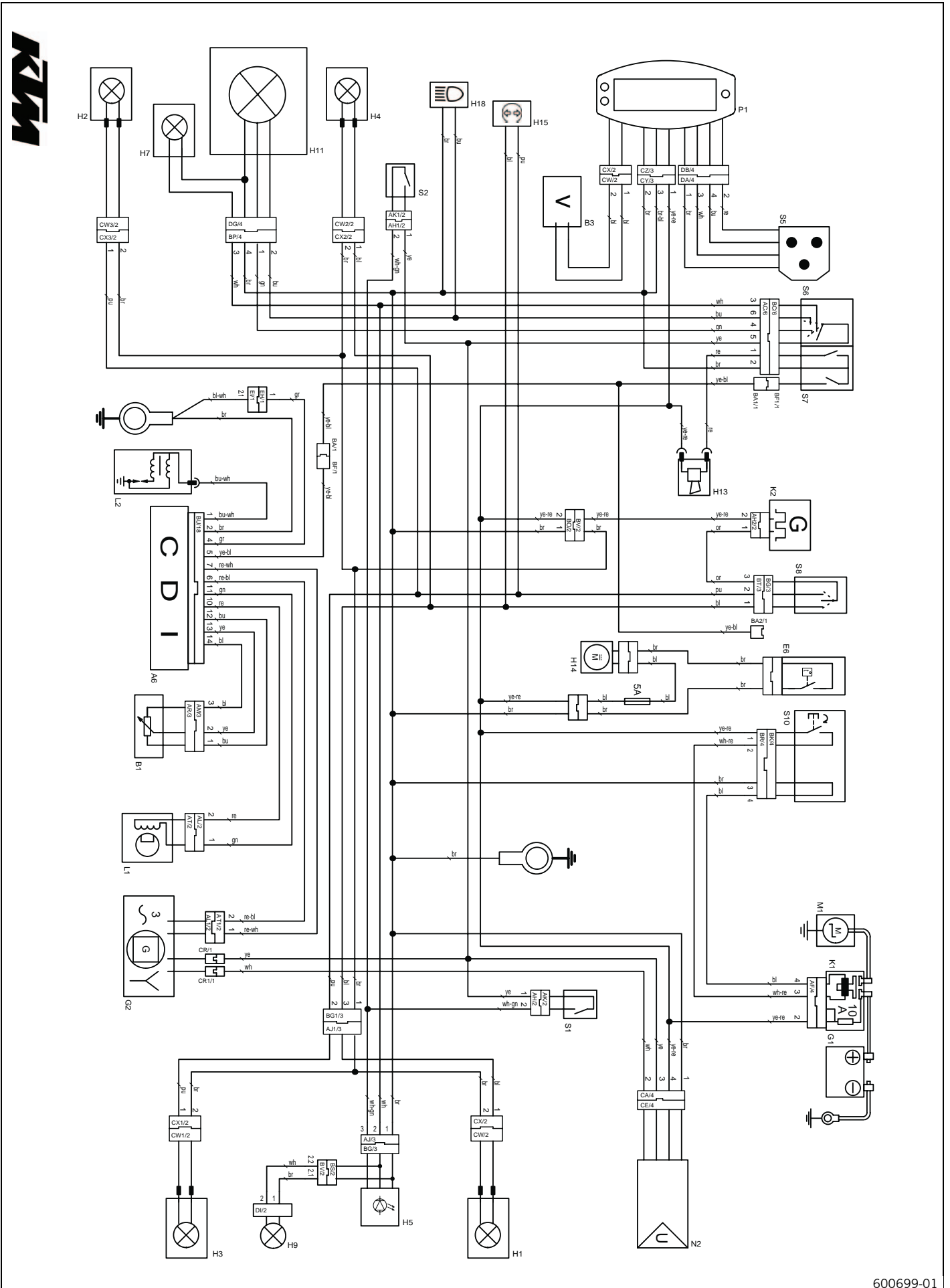

Components

A6	CDI controller
B1	Throttle position sensor
B3	Wheel speed sensor
E6	Thermoswitch (EXC-F SIX DAYS)
G1	Battery
G2	Generator
H1	Right rear flasher
H2	Left front flasher
H3	Left rear flasher
H4	Right front flasher
H5	Brake/tail light
H7	Parking light
H9	License plate lamp
H11	Low/high beam
H13	Horn
H14	Radiator fan (EXC-F SIX DAYS)
H15	Flasher indicator light
H18	High beam indicator light
K1	Starter relay with main fuse
K2	Flasher relay
L1	Pulse generator
L2	Ignition coil
M1	Starter motor
N2	Voltage regulator/rectifier
P1	Speedometer
S1	Rear brake light switch
S2	Front brake light switch
S5	Tripmaster switch (optional)
S6	Light switch
S7	Horn button, short circuit button
S8	Flasher switch
S10	Electric starter button

Cable colors

bl	Black
bl-wh	Black-white
br	Brown
br-bl	Brown-black
bu	Blue
bu-wh	Blue-white
gn	Green
gr	Gray
or	Orange
pu	Violet
re	Red
re-bl	Red-black
re-wh	Red-white
wh	White
wh-gn	White-green
wh-re	White-red
ye	Yellow
ye-bl	Yellow-black

ye-re Yellow-red

Wiring diagram (250 EXC-F AUS)

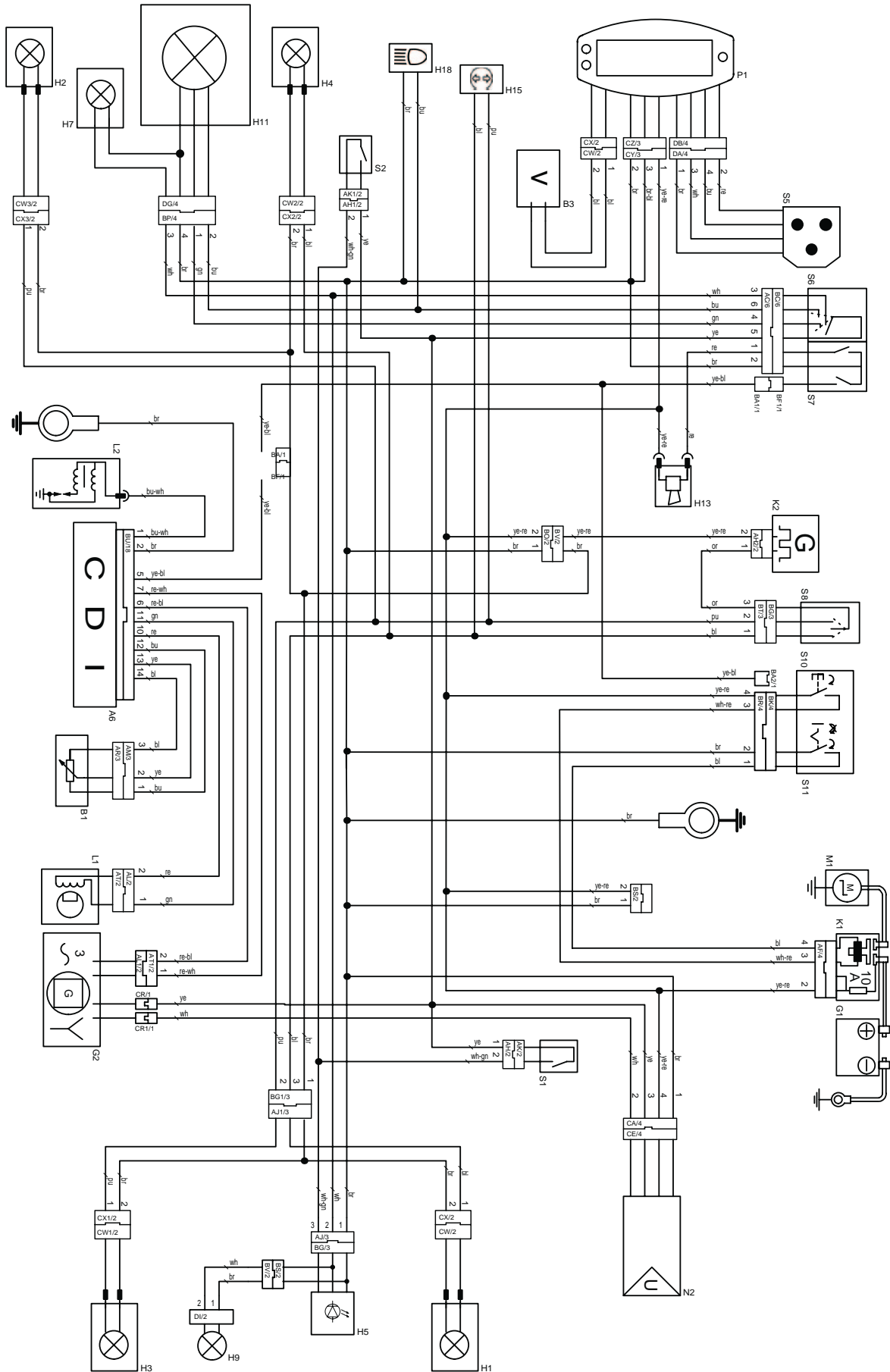

Components

A6	CDI controller
B1	Throttle position sensor
B3	Wheel speed sensor
G1	Battery
G2	Generator
H1	Right rear flasher
H2	Left front flasher
H3	Left rear flasher
H4	Right front flasher
H5	Brake/tail light
H7	Parking light
H9	License plate lamp
H11	Low/high beam
H13	Horn
H15	Flasher indicator light
H18	High beam indicator light
K1	Starter relay with main fuse
K2	Flasher relay
L1	Pulse generator
L2	Ignition coil
M1	Starter motor
N2	Voltage regulator/rectifier
P1	Speedometer
S1	Rear brake light switch
S2	Front brake light switch
S5	Tripmaster switch (optional)
S6	Light switch
S7	Horn button, short circuit button
S8	Flasher switch
S10	Electric starter button
S11	Emergency OFF switch

Cable colors

bl	Black
br	Brown
br-bl	Brown-black
bu	Blue
bu-wh	Blue-white
gn	Green
or	Orange
pu	Violet
re	Red
re-bl	Red-black
re-wh	Red-white
wh	White
wh-gn	White-green
wh-re	White-red
ye	Yellow
ye-bl	Yellow-black
ye-re	Yellow-red

Wiring diagram (XCF-W, 250 XC-F USA)

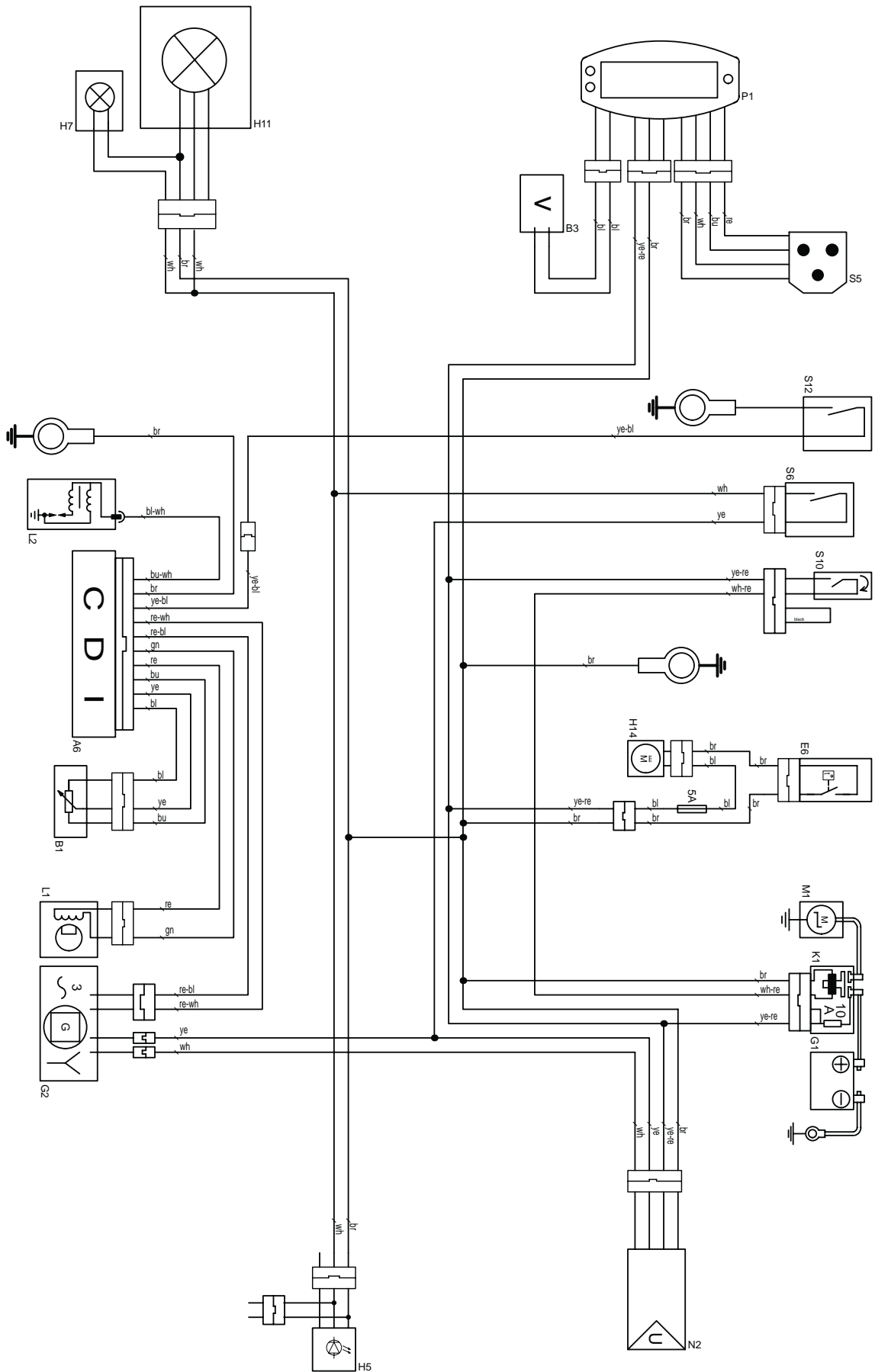

Components

A6	CDI controller
B1	Throttle position sensor
B3	Wheel speed sensor
E6	Thermoswitch (XCF-W ZA)
G1	Battery
G2	Generator
H5	Brake/tail light (XCF-W ZA)
H7	Parking light (XCF-W ZA)
H11	Low beam (XCF-W ZA)
H14	Radiator fan (XCF-W ZA)
K1	Starter relay with main fuse
L1	Pulse generator
L2	Ignition coil
M1	Starter motor
N2	Voltage regulator/rectifier
P1	Speedometer
S5	Tripmaster switch (optional)
S6	Light switch
S10	Electric starter button
S12	Short circuit button

Cable colors

bl	Black
bl-wh	Black-white
br	Brown
bu	Blue
bu-wh	Blue-white
gn	Green
re	Red
re-bl	Red-black
re-wh	Red-white
wh	White
wh-re	White-red
ye	Yellow
ye-bl	Yellow-black
ye-re	Yellow-red

Wiring diagram (SX-F)

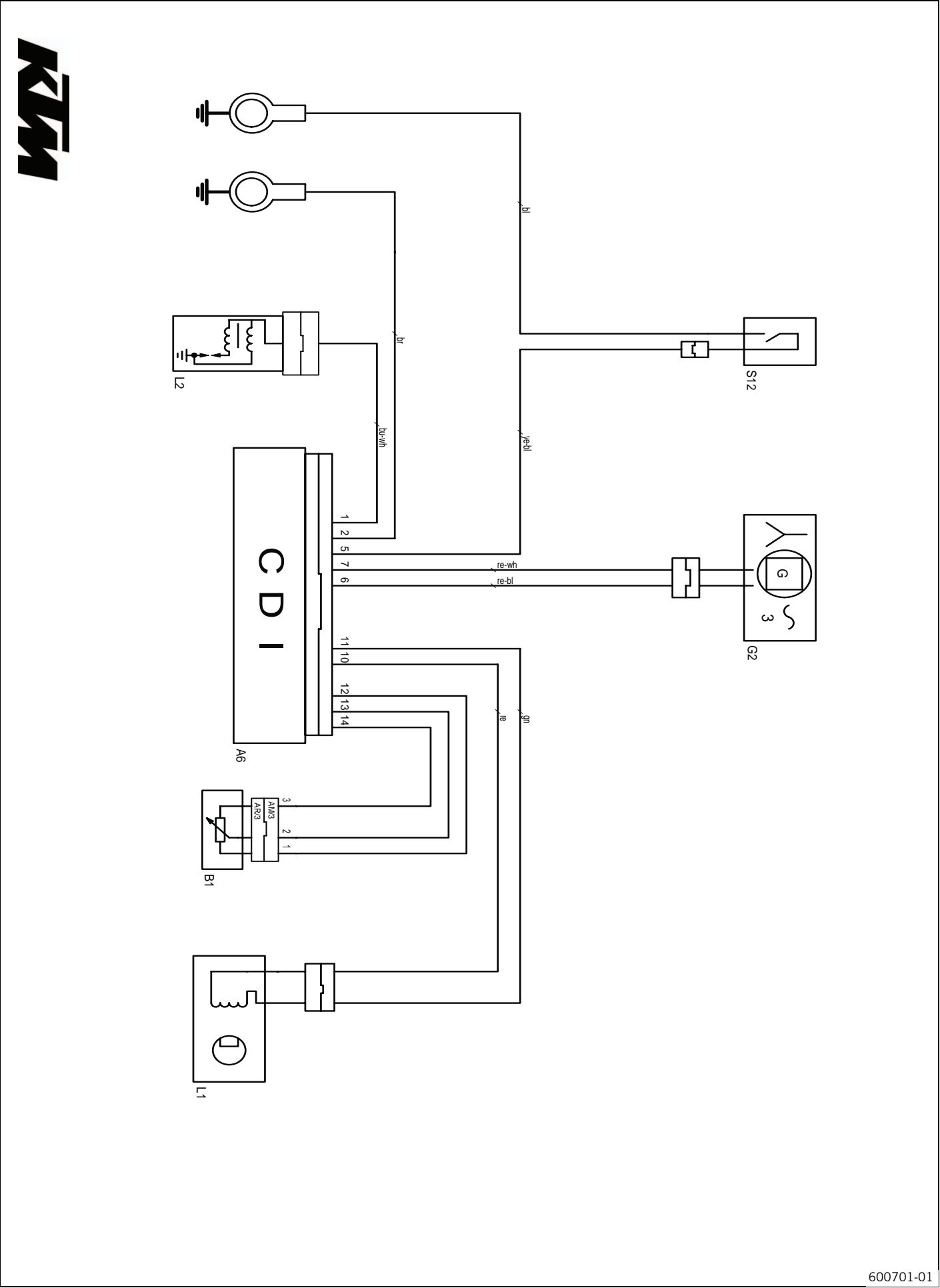

Components

A6	CDI controller
B1	Throttle position sensor
G2	Generator
L1	Pulse generator
L2	Ignition coil
S12	Short circuit button

Cable colors

bl	Black
br	Brown
bu-wh	Blue-white
gn	Green
re	Red
re-bl	Red-black
re-wh	Red-white
ye-bl	Yellow-black

Brake fluid DOT 4 / DOT 5.1

According to

- DOT

Guideline

- Use only brake fluid that complies with the specified standards (see specifications on the container) and that possesses the corresponding properties. KTM recommends **Castrol** and **Motorex®** products.

Supplier

Castrol

- **RESPONSE BRAKE FLUID SUPER DOT 4**

Motorex®

- **Brake Fluid DOT 5.1**

Coolant

Guideline

- Use only suitable coolant (even in countries with high temperatures). Using inferior antifreeze can result in corrosion and foaming. KTM recommends **Motorex®** products.

Mixture ratio

Antifreeze: -25... -45 °C (-13... -49 °F)	50 % Anti-corrosion/antifreeze 50 % distilled water
---	--

Coolant (mixed ready to use)

Antifreeze	-40 °C (-40 °F)
------------	-----------------

Supplier

Motorex®

- **Anti Freeze**

Engine oil (SAE 10W/50)

According to

- JASO T903 MA (☛ p. 119)
- SAE (☛ p. 119) (SAE 10W/50)

Guideline

- Use only engine oils that comply with the specified standards (see specifications on the container) and that possess the corresponding properties. KTM recommends **Motorex®** products.

Synthetic engine oil

Supplier

Motorex®

- **Cross Power 4T**

Fork oil (SAE 5)

According to

- SAE (☛ p. 119) (SAE 5)

Guideline

- Use only oils that comply with the specified standards (see specifications on the container) and that possesses the corresponding properties. KTM recommends **Motorex®** products.

Supplier

Motorex®

- **Racing Fork Oil**

Super unleaded (ROZ 95 / RON 95 / PON 91)

According to

- DIN EN 228 (ROZ 95 / RON 95 / PON 91)

Air filter cleaner

Specification

- KTM recommends **Motorex®** products.

Supplier

Motorex®

- **Twin Air Dirt Bio Remover**

Chain cleaner

Specification

- KTM recommends **Motorex®** products.

Supplier

Motorex®

- **Chain Clean 611**

Cleaning and polishing materials for metal, rubber and plastic

Specification

- KTM recommends **Motorex®** products.

Supplier

Motorex®

- **Protect & Shine 645**

Contact spray

Specification

- KTM recommends **Motorex®** products.

Supplier

Motorex®

- **Accu Contact**

High-luster polish for paint

Specification

- KTM recommends **Motorex®** products.

Supplier

Motorex®

- **Moto Polish**

Long-life grease

Specification

- KTM recommends **Motorex®** products.

Supplier

Motorex®

- **Fett 2000**

Motorcycle cleaner

Specification

- KTM recommends **Motorex®** products.

Supplier

Motorex®

- **Moto Clean 900**

Offroad chain spray

Specification

- KTM recommends **Motorex®** products.

Supplier

Motorex®

- **Chain Lube 622**

Oil for foam air filter

Specification

- KTM recommends **Motorex®** products.

Supplier

Motorex®

- **Twin Air Liquid Power**

Universal oil spray

Specification

- KTM recommends **Motorex®** products.

Supplier

Motorex®

- **Joker 440 Universal**

JASO T903 MA

Different technical development directions required a new specification for 4-stroke motorcycles – the JASO T903 MA Standard. Earlier, engine oils from the automobile industry were used for 4-stroke motorcycles because there was no separate motorcycle specification. Whereas long service intervals are demanded for automobile engines, high performance at high engine speeds are in the foreground for motorcycle and ATV engines. With most motorcycles and ATVs, the gearbox and the clutch are lubricated with the same oil as the engine. The JASO MA Standard meets these special requirements.

SAE

The SAE viscosity classes were defined by the Society of Automotive Engineers and are used for classifying oils according to their viscosity. The viscosity describes only one property of oil and says nothing about quality.

A	
Accessories	6
Air filter	
cleaning	83
installing	83
removing	83
Air filter box lid	
installing	82
removing	82
Antifreeze	
checking	80
B	
Basic chassis setting	
checking with rider's weight	37
Battery	
installing	76
recharging	76
removing	75
Brake discs	
checking	64
Brake fluid	
front brake, adding	65
rear brake, adding	69
Brake fluid level	
of front brake, checking	65
of rear brake, checking	69
Brake linings	
front brake, changing	67
front brake, checking	66
front brake, installing	67
front brake, removing	66
of rear brake, removing	70
rear brake, changing	71
rear brake, checking	70
rear brake, installing	70
C	
Carburetor	
adjusting idle	84
emptying the float chamber	85
idle	84
Chain	
cleaning	57
Chain guide	
adjusting	61-62
Chain tension	
adjusting	59
checking	58
Chain wear	
checking	59
Chassis number	10
Choke	23
CLEANING	92
Clutch	
changing fluid	63
checking fluid level	62

Clutch lever	12
adjusting basic position	62
Compression damping	
fork, adjusting	43
Compression damping, high-speed	
shock absorber, adjusting	37
Compression damping, low-speed	
shock absorber, adjusting	38
Coolant	
draining	81
refilling	81
Coolant level	
checking	80
Cooling system	79
D	
Dust boots	
cleaning	46
E	
Electric starter button	13
Emergency OFF switch	12
Engine	
running in	27
Engine number	10
Engine oil	
adding	89
changing	86
draining	86
refilling	89
Engine oil level	
checking	86
Environment	7
F	
Filler cap	
closing	23
opening	22
Filling up	
Fuel	30
Flasher switch	14
Foot brake pedal	24
adjusting basic position	68
checking free travel	68
Fork	
checking basic setting	43
Fork legs	
bleeding	45
installing	49
removing	48
Fork offset	48
adjusting	48
Fork protector	
installing	50
removing	50
Front fender	
installing	53

- removing 53
- Front wheel**
 - installing 72
 - removing 72
- Fuel tank**
 - installing 79
 - removing 78
- Fuel tap** 22
- Fuel, oils, etc.** 6
- Fuse**
 - installing 77
 - removing 77
- G**
- Gas Bowden cable route**
 - checking 56
- H**
- Hand brake lever** 12
 - adjusting basic position 64
 - adjusting free travel 65
 - checking free travel 64
- Handlebar position** 54
 - adjusting 55
- Horn button** 13
- K**
- Key number** 10
- Kickstarter** 24
- L**
- Light switch** 13
- Lower triple clamp**
 - fitting 52
 - installing 51
 - removing 50-51
- M**
- Main silencer**
 - installing 82
 - removing 82
- Maintenance** 6
- Motorcycle**
 - cleaning 92
- O**
- Oil filter**
 - changing 86
 - installing 88
 - removing 88
- Oil screen**
 - cleaning 86
- Oil screens**
 - cleaning 87
- Overview of indicator lamps** 14
- OWNER'S MANUAL** 7
- P**
- Play in gas Bowden cable**
 - adjusting 57
 - checking 56
- Plug-in stand** 24
- Putting into operation**
 - advice on first use 26
 - after storage 93
 - Checks before putting into operation 28
- R**
- Rear sprocket / engine sprocket**
 - checking for wear 59
- Rear wheel**
 - installing 73
 - removing 73
- Rebound damping**
 - fork, adjusting 44
 - shock absorber, adjusting 39
- Riding sag**
 - adjusting 42
- S**
- Seat**
 - mounting 78
 - removing 77
- Service schedule**
 - EXC-F, EXC-F SIX DAYS, XCF-W 32-33
 - rider 36
 - XC-F, SX-F 34-35
- Shift lever** 23
- Shock absorber**
 - installing 42
 - removing 42
 - riding sag, checking 41
 - static sag, checking 40
- Short circuit button** 12
- Side stand** 24
- Spare parts** 6
- Speedometer**
 - adjusting 16
 - Function description 15
 - Setting kilometers or miles 15
 - Setting the clock 16
- Spoke tension**
 - checking 75
- Spring preload**
 - fork, adjusting 45
 - shock absorber, adjusting 41
- Start number plate**
 - installing 54
 - removing 54
- Starting** 28
- steering**
 - locking 25
 - unlocking 25
- Steering head bearing**
 - greasing 53
- Steering head bearing play**
 - adjusting 47
 - checking 46

Storage 93

T

Technical data

carburetor 98
chassis 99-100
engine 94-95
fork 101-102
shock absorber 103-104
tightening torques, chassis 105
tightening torques, engine 96-97

Tire air pressure

checking 75

Tire condition

checking 74

Transport 6

TROUBLESHOOTING 90-91

Type label 10

V

View of vehicle

left front 8
right rear 9

W

Warranty 6

Wiring diagram 106-115

Work rules 6



3211348en



09/2008 Photo: Mitterbauer



KTM-Sportmotorcycle AG
5230 Mattighofen/Austria
<http://www.ktm.com>