



RR 350-390-430-480 EFI

Thanks for your preference, and have a good time! This handbook contains the information you need to properly operate and maintain your motorcycle.

The data, specifications and images shown in this manual does not constitute an engagement on the part of BETAMOTOR S.p.A. BETAMOTOR reserves the right to make any changes and improvements to its models at any moment and without notice.

Code 031440420 000

IMPORTANT

We recommend you to check all the tightenings after the first one or two hours' ride over rough ground. Special attention should be paid to the following parts:

- rear sprocket
- ensure that the footrests are properly fixed
- front/rear brake levers/calipers/discs
- check that the plastics are properly fastened
- engine bolts
- shock absorber bolts/swingarm
- wheel hubs/spokes
- rear frame
- pipe connections
- tensioning the chain

IMPORTANT

In the event of interventions on the vehicle, contact Betamotor after-sales service.

CONTENTS	
Operating instructions.....	5
Symbols.....	5
Riding safety	6
CHAPTER 1 GENERAL INFORMATION	7
Vehicle identification data	8
Tools kit	8
Familiarizing with the vehicle.....	9
Specifications	10
Recommended lubricants and liquid	13
CHAPTER 2 OPERATION	15
Main parts	16
Digital rpm indicator operating instructions.....	20
Checks before and after use	30
Running in.....	30
Fuelling.....	31
Starting the engine	32
Engine shut-down	32
Vehicle preparation for use in heavy-duty conditions.....	33
CHAPTER 3 ADJUSTMENTS.....	35
Key to symbols.....	36
Brakes	36
Clutch.....	36
Adjustment of gas clearance.....	37
Idle adjustment	37
Handlebar adjustment	37
Adjusting fork.....	39
Shock absorber.....	39
CHAPTER 4 CHECKS AND MAINTENANCE	43
Engine oil.....	44
Gearbox oil	46
Liquid coolant.....	47
Air filter	49
Spark plug	51
Front brake.....	52
Rear brake	55

Clutch control	58
Check and adjusting of steering play	60
Oil fork	61
Rear suspension leverage	64
Tyres	65
Chain	65
Headlight	67
Replacing the headlight bulbs	67
Tail light	67
Battery	68
Fuses	70
Cleaning the vehicle	71
Electrical connector maintenance	72
Prolonged inactivity	74
Scheduled maintenance vehicle	75
Tightening torque overview	77
CHAPTER 5 REMOVING AND INSTALLING SUPERSTRUCTURES	79
Removing and installing of the saddle	80
Removing and installing air filter cover panel	81
Removing and installing of the tank	82
CHAPTER 6 TROUBLESHOOTING	83
Troubleshooting	84











OPERATING INSTRUCTIONS

- The vehicle must be accompanied by: number-plate, registration document, tax disc and insurance.
- Do not sit on the vehicle when it is on its stand.
- Do not start the engine in closed places.

WARNING

Any modifications and tampering with the vehicle during the warranty period exempt the manufacturer from all responsibility and invalidate warranty.

SYMBOLS

-  SAFETY/ATTENTION
Failure to respect information marked with this symbol can entail a personal hazard.
-  INTEGRITY OF THE VEHICLE
Failure to respect information marked with this symbol can entail serious damage to the vehicle and termination of the warranty.
-  FLAMMABLE LIQUID HAZARD
-  Read the use and maintenance manual carefully.
-  MANDATORY TO WEAR PROTECTIVE CLOTHING
Use of the vehicle is subject to wearing specific protective clothing and safety footwear.
-  PROTECTIVE GLOVES MANDATORY
To perform the operations described, it is mandatory to wear protective gloves.
-  FORBIDDEN TO USE NAKED FLAMES OR POSSIBLE UNCONTROLLED IGNITION SOURCES
-  NO SMOKING
-  DO NOT USE MOBILE PHONE
-  CORROSIVE SUBSTANCES HAZARD
Liquids marked with this symbol are highly corrosive: handle with care
-  POISONING HAZARD

RIDING SAFETY

- Observe the Highway Code.
- Always wear approved personal protective equipment.
- Always keep the crash helmet visor clean.
- Do not keep sharp or brittle objects in your pockets while riding.
- Properly adjust the rearview mirrors.
- Always ride in a seated position, with both hands on the handlebars and both feet on the footrests.
- Never ride abreast with other vehicles.
- Do not tow and avoid being towed by other vehicles.
- Always keep a safe distance from other vehicles.
- Do not start off while the vehicle is on its stand.
- Avoid swaying and wheelies as they are extremely dangerous for your own and other people's safety as well as for your vehicle.
- Always apply both brakes on dry roads with no gravel and sand. Using one brake may be dangerous and cause uncontrolled skidding.
- To reduce the braking distance, always apply both brakes.
- On wet roads and in off-road riding, drive with care and at moderate speed. Take special care in applying the brakes.

CHAPTER 1 GENERAL INFORMATION

CONTENTS

Vehicle identification data	8
Frame identification	8
Engine identification	8
Tools kit	8
Familiarizing with the vehicle.....	9
Main parts.....	9
Specifications	10
Weight.....	10
Dimensions	10
Tyres.....	10
Capacities	10
Front suspension.....	11
Rear suspension	11
Front brake.....	11
Rear brake	11
Engine	12
Recommended lubricants and liquid	13

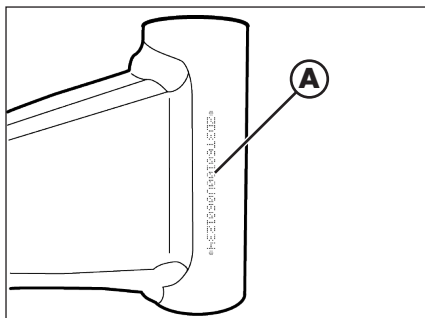

VEHICLE IDENTIFICATION DATA

FRAME IDENTIFICATION

Frame identification data **A** are stamped on the right side of the steering head tube.

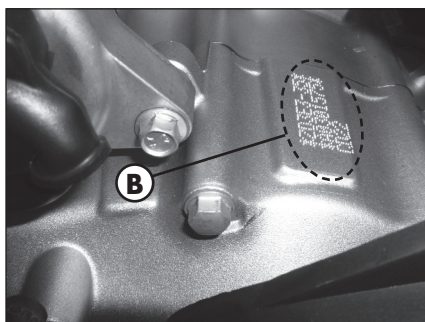

ENGINE IDENTIFICATION

Engine identification data **B** are stamped in the area shown in the figure.



TOOLS KIT

The following items are supplied as standard: operation, maintenance manual, tool kit and the cable adapter to connect the CAN socket to a scantool (see photo).

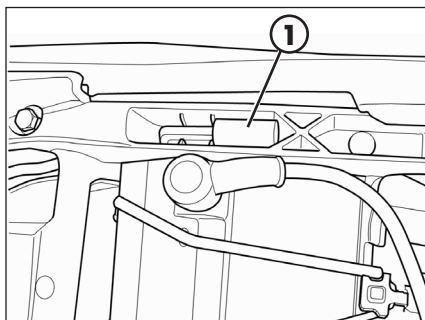

The hex key **1** and its socket wrench (8 mm) are found inside the battery compartment. Remove the seat to reach them (page 80).

FAMILIARIZING WITH THE VEHICLE

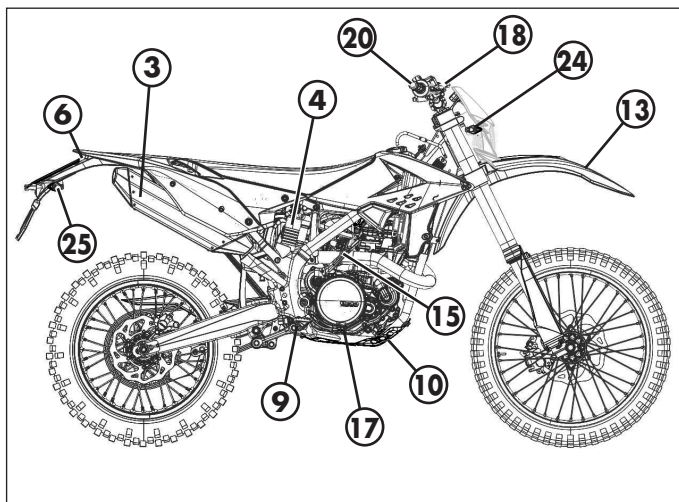
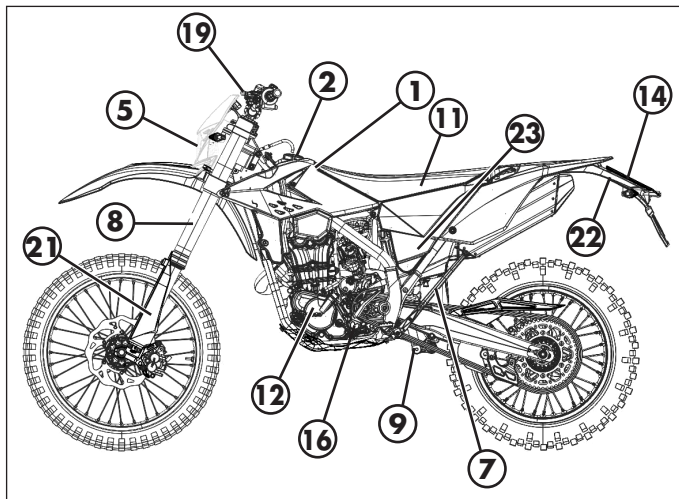

MAIN PARTS

- | | | |
|-------------------------|-----------------------------------|------------------------|
| 1 - Fuel tank | 10 - Lower bumper
(Bumper kit) | 18 - Front brake lever |
| 2 - Tank cap | 11 - Saddle | 19 - Clutch lever |
| 3 - Silencer | 12 - Engine | 20 - Throttle |
| 4 - Rear shock absorber | 13 - Front mudguard | 21 - Fork covers |
| 5 - Headlight | 14 - Number-plate holder | 22 - Rear mudguard |
| 6 - Rear light | 15 - Kick-start | 23 - Cover air filter |
| 7 - Side stand | 16 - Gear lever | 24 - Front indicators |
| 8 - Fork | 17 - Rear brake lever | 25 - Rear indicators |
| 9 - Rider's footrests | | |

SPECIFICATIONS

WEIGHT

Weight in running order with full fuel and optional

Version	Total [kg]	Front [kg]	Rear [kg]
RR 350 - RR 390	126,5	61,8	64,7
RR 430 - RR 480	127,5	62	65,5

DIMENSIONS

maximum length (with plate holder)	2270 mm
maximum width	807 mm
overall height	1270 mm
wheelbase.....	1490 mm
saddle height.....	940 mm
ground clearance.....	320 mm
footrest height.....	413 mm

TYRES

Dimensions		Pressure [Bar]	
Front tyre	Rear tyre	Front tyre	Rear tyre
90/90-21	140/80-18	1,5 (road use)	1,8 (road use)
		1 (off-road use)	1 (off-road use)

front rim	21x1,6 - 36 holes
rear rim	18x2,15 - 36 holes

CAPACITIES

fuel tank.....	8 liter
including reserve.....	2 liter
coolant circuit.....	1,3 liter
engine oil.....	750 ml following normal maintenance work
.....	800 ml following a complete engine review
gear oil.....	750 ml following normal maintenance work
.....	800 ml following a complete engine review

FRONT SUSPENSION

Hydraulic upside-down fork (shafts Ø48 mm) with open cartridge

Spring	K 4,8
Oil type	Liqui Moly SAE 5W
Oil quantity	545 g
Compression clicks (from completely closed)	14
Rebound clicks (from completely closed)	14

REAR SUSPENSION

Single shock absorber with compound lever

Spring	K 5,4
Static sag load (see page 41)	35 mm
Compression clicks, high speeds (from completely closed)	21
Compression clicks, low speeds (from completely closed)	24
Rebound clicks (from completely closed)	20
Rear wheel travel	290 mm

FRONT BRAKE

Ø 260 mm disc and dual-piston floating caliper

REAR BRAKE

Ø240 mm disc and single-piston floating caliper

ENGINE

Version	RR 350	RR 390	RR 430	RR 480
Type	Single-cylinder, 4-stroke			
Bore x stroke [mm]	88x57,4	88x63,4	95x60,8	100x60,8
Displacement [cm ³]	349,1	386	431	478
Compression ratio	13,19:1	12,5:1	12,3:1	11,9:1
CO ₂ [g/km] * #	93	94	94	102
Fuel consumption [l/100km] * #	3,842	3,896	3,887	4,219

* Only valid for EUROPA version

WMTc cycle related data, for class L vehicles

Fuel system.....electronic injection, double injector

Cooling system forced liquid circulation by pump

Spark plug NGK LKAR 8A - 9

Clutch..... wet, multidisc

Transmission..... 6-speed with front claw clutch

Version	RR 350	RR 390	RR 430	RR 480
Primary drive	28/76	28/76	31/72	31/72
Gear ratio 1 st gear	12/31	12/31	12/31	12/31
Gear ratio 2 nd gear	15/28	15/28	15/28	15/28
Gear ratio 3 rd gear	19/28	19/28	19/28	19/28
Gear ratio 4 th gear	20/24	20/24	20/24	20/24
Gear ratio 5 th gear	27/27	27/27	27/27	27/27
Gear ratio 6 th gear	28/24	28/24	28/24	28/24
Final drive	15/45 * 13/50	15/45 * 13/49	15/45 * 13/48	15/45 * 13/48

* Only valid for EUROPA version

Starting..... electric starter (Kick-starter optional)

RECOMMENDED LUBRICANTS AND LIQUID

To maximize the vehicle's performance and ensure many years of trouble-free operation, we recommend using the following products:

PRODUCT TYPE	SPECIFICATIONS
ENGINE OIL	Liqui Moly racing Synth 10W50
GEAR AND CLUTCH OIL	Liqui Moly racing Synth 10W50
BRAKE OIL	Liqui Moly brake fluid DOT 5.1
CLUTCH ACTUATOR OIL	Liqui Moly brake fluid DOT 5.1
FORK OIL	Liqui Moly SAE 5W
TIE ROD GREASE	Liqui Moly Schmierfix
LIQUID COOLANT	Liqui Moly Coolant ready mix RAF 12 PLUS

Note:

It is essential that all renewals should be performed with the products listed in the table above.

CHAPTER 2 OPERATION

CONTENTS

Main parts	16
Clutch lever	16
LH switch.....	16
RH switch	16
Front brake lever and gas control	17
Gear change lever.....	17
Brake pedal	17
Kickstart - Optional	17
Side stand	18
Keys	18
Steering lock.....	19
Digital rpm indicator operating instructions.....	20
Checks before and after use	30
Running in.....	30
Fuelling.....	31
Starting the engine	32
Engine shut-down	32
Vehicle preparation for use in heavy-duty conditions.....	33

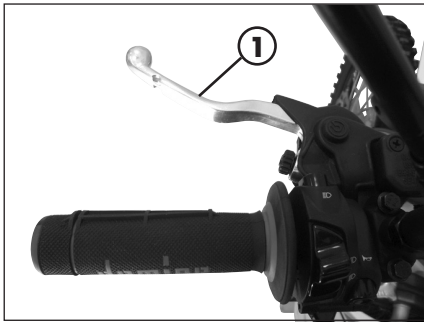

MAIN PARTS

CLUTCH LEVER

Clutch lever **1** is fitted to the left-hand side of the handlebars.

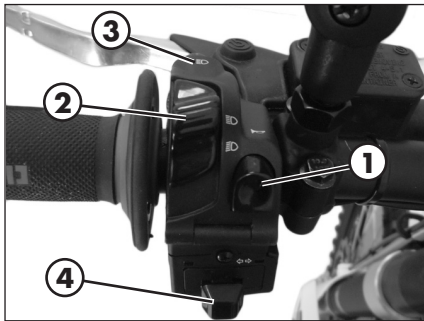

LH SWITCH

The dip and service switch is located on the left side of the handlebar and is composed as follows:

1 - Horn button;

2 - Dip switch:

 parking lights and high beam;

 parking lights and low beam;

3 - Flash-to-pass button;

4 - Turn signal light switch: shifting lever left or right activates the left or right indicators. When released, the lever returns to the central position. Press it to turn the indicators off.

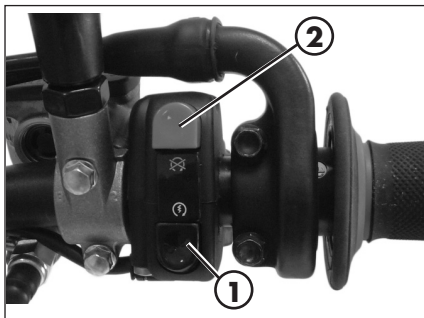

RH SWITCH

Starter button **1** is located on the right-hand side of the handlebars and operate the electric engine starter. For startup, refer to page 32.

Do not press the button **1** while the engine is running.

The button **2** turns off the engine.

FRONT BRAKE LEVER AND GAS CONTROL

The front brake lever **A** and the gas throttle **B** are located on the right side of the handlebar.

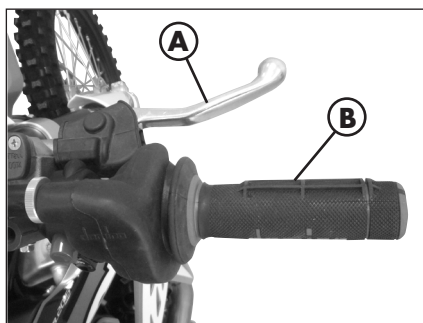

GEAR CHANGE LEVER

Gear change lever is fitted to the left side of the engine.

The positions corresponding to the different gears are shown in the figure.

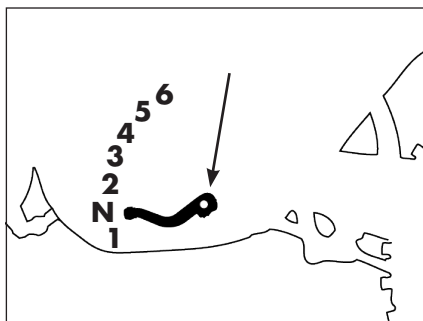

BRAKE PEDAL

Brake pedal is located in front of the right-hand footrest.

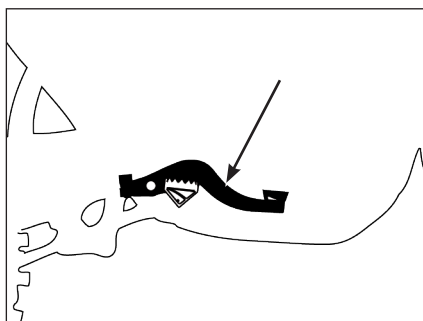

KICKSTART - OPTIONAL

The kick-starter pedal is located on the right side of the engine. The upper part is rotatable. To start, depress the kick-starter outward and with a quick movement downward.

The pedal will automatically return upwards. After starting, manually fold the pedal in the rest position.

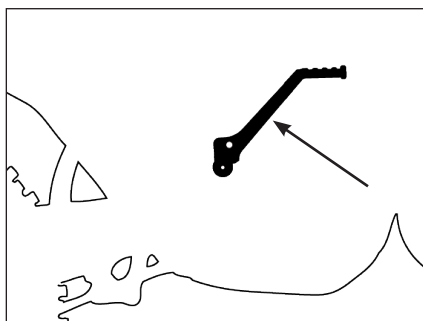

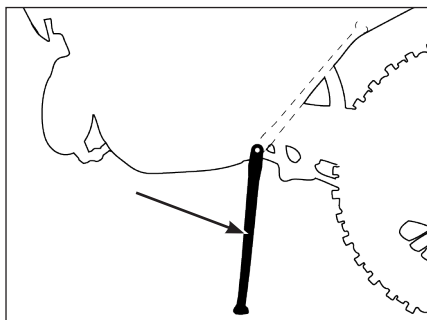

SIDE STAND

Press down side stand with the foot and lean the vehicle against it.

Ensure that the ground is solid and the vehicle stands steadily.



WARNING: do not climb on the vehicle when the side stand is down.

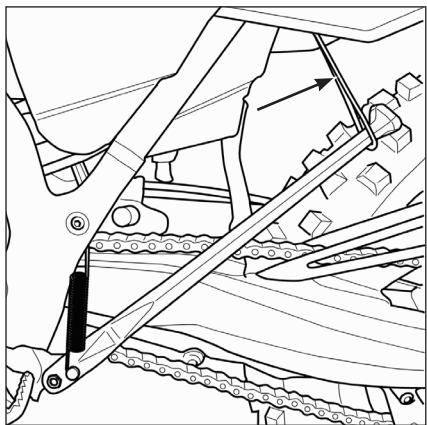

If the vehicle is used off-road, the closed stand can be further fastened by means of rubber band.

KEYS

The vehicle is supplied with two keys (one key and its spare).

STEERING LOCK

To activate the steering lock:

- turn the handlebar counter-clockwise;
 - push the key and turn counter-clockwise;
- Remove the key from this position.

To deactivate the steering lock:

- turn the key clockwise;
- turn the handlebar clockwise;

From this position, the handlebar is free to move, the key can be removed.

WARNING: do not keep the spare key inside the vehicle, but in a safe place.

We suggest you note the code number stamped on the keys. In this way you can obtain a duplicate.

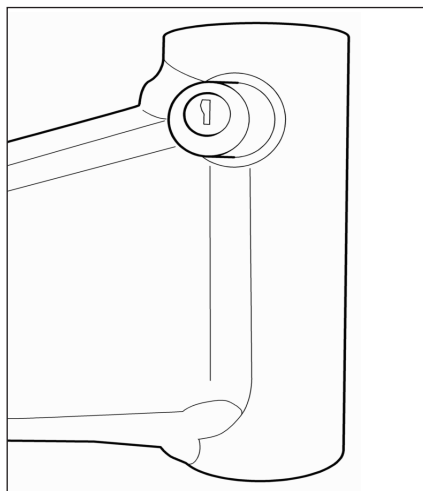

Index

- 1 General information
- 2 Operating condition
- 3 General characteristics
 - 3.1 Dashboard start-up process
 - 3.1.1 Wake up events
 - 3.2 LCD Display
 - 3.2.1 LCD general characteristics
 - 3.2.2 Speed
 - 3.2.3 Odometer
 - 3.2.4 Trip A
 - 3.2.5 Trip B
 - 3.2.6 Clock
 - 3.2.7 Ride Time
 - 3.2.8 Unit option display
 - 3.2.9 Wheel length display
 - 3.2.10 Motorbike battery level
 - 3.2.11 Push Button Management Table
 - 3.3 Telltales
- 4 Coin battery

1 GENERAL INFORMATION

The dashboard integrates these main blocks:

- LCD display for showing all required information
- 2 pushbuttons
- Coin battery

**2 OPERATING CONDITION**

Standard supply voltage: 10 to 16V
 Minimum supply voltage w/o reset: 6.5V

3 GENERAL CHARACTERISTICS

3.1 DASHBOARD START-UP PROCESS

The dashboard do some start-up process when is turned ON. There are three different wakes up events for starting the dashboard.

This start-up process consists in turning ON the telltales and the LCD backlight and the LCD will show all the segments during 2 seconds.

After the start-up process, dashboard is kept ON during 30 seconds if there are no events as pushbutton press, speed signal or engine ON.

3.1.1 WAKE UP EVENTS

3.1.1.1 Motorbike power supply is activated

When the power supply of dashboard is activated (e.g. when engine is turned on), the dashboard does the normal start-up process and is kept ON while

3.1.1.2 Wheel revolution

If the motorbike generated a speed pulse, the dashboard will be turned ON doing the normal start-up process. After the start-up process the dashboard will display the normal mode, and will be ON during 30 seconds if no speed pulse is generated.

3.1.1.3 Button is pushed

If one or both buttons are pushed the dashboard will be turned ON doing the start-up process.

After the start-up process the dashboard will display the normal mode, and will be ON during 30 seconds if no pushbutton is pressed.

3.2 LCD DISPLAY

Dashboard is equipped with a LCD display for showing following information:

- Speed
- SoC vehicle battery
- Odometer (distance or ride time)
- Trip TOTAL-A-B (distance or ride time)
- Clock

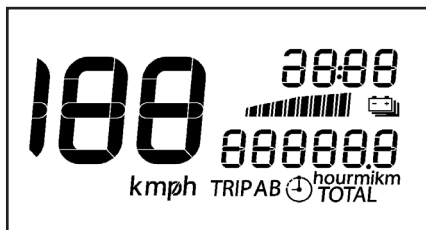

Each information/data is refreshed independently at different rate, depending on information type and variability of this information.

3.2.1 LCD GENERAL CHARACTERISTICS

Each information/data is refreshed independently at different rates, depending on information type and variability of this information.

3.2.2 SPEED

Dashboard computes and displays the motorbike speed on LCD display. Speed information can be obtained from:

Dedicated digital input for measuring speed sensor frequency.

3.2.2.1 Speed digital input configuration

Configuration parameters for speed input and speed visualization.

Dimensions displayed: [km/h or mph]

Minimum speed indication: [5 km/h]

Speedometer advance: [5 %]

Wheel parameters:

- Wheel perimeter selectable between 2 values:
 - Default wheel perimeter value: (enduro) 2100mm
 - 2nd wheel perimeter value: 1811mm
- Pulses per turn: [1 pulses/turn]

3.2.2.2 Speed LCD

Speed and speed units are permanently displayed (km/h or mph).

km/h display range: 0 to 199km/h.

mph display range: 0 to 199mph.

Leading zeros suppressed.

Following picture shows LCD displaying speed in km/h and mph:

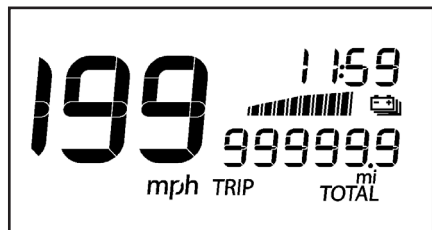
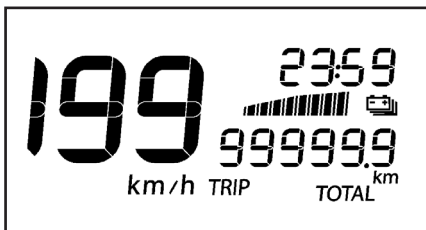

3.2.3 ODOMETER

Dashboard provides an odometer and is displayed on LCD display.

This option can be displayed scrolling by "MODE" button.

6 digits and "ODO" icon lighted.

Leading zeros not suppressed.

Display range from 000000 to 999999 km or miles. If odometer is greater than 999999 km, odometer will be fixed as 999999km.

Minimum display unit: 1 km or mile.

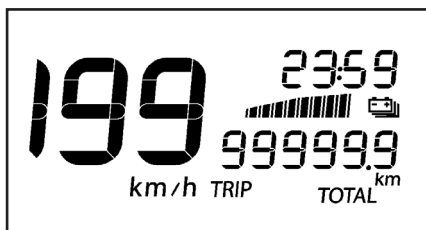

3.2.4 TRIP A

Dashboard provides 2 trips and is displayed on LCD display.

This option can be displayed scrolling by "MODE" dashboard button.

4 digits (3digits + decimal point + 1 digit), "TRIP" icon lighted and "A" on the left. Leading zeros suppressed.

Display range from 0.0 to 999.9 km or miles.

Trip A counter counts from 0 up to 999.9 and then rolls over to 0 and continue counting.

Minimum display unit: 0.1 km or miles.

Trip A reset by pressing "SET" button more than 2 seconds.

Trip A display the Trip A ride time pressing "SET" button less than 2 seconds. Ride time is showed as an hour decimal number. Examples: 30 min is 0.5 or 1h20min is 1.3.

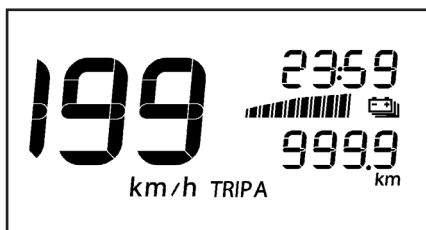

3.2.5 TRIP B

This option can be displayed scrolling by "MODE" dashboard button.

4 digits (3digits + decimal point + 1 digit), "TRIP" icon lighted and "B" on the left. Leading zeros suppressed.

Display range from 0.0 to 999.9 km or miles.

Trip B counter counts from 0 up to 999.9 and then rolls over to 0 and continue counting.

Minimum display unit: 0.1 km or miles.

Trip B reset by pressing "SET" button more than 2 seconds.

Trip B display the Trip B ride time pressing "SET" button less than 2 seconds. Ride time is showed as an hour decimal number. Examples: 30 min is 0.5 or 1h20min is 1.3 .



3.2.6 CLOCK

Dashboard provides a clock and is displayed on LCD display. Time is obtained from internal crystal quartz and is kept while dashboard is connected to coin battery.

Clock format	If units of measure are km 24h
	If units of measure are mi 12h

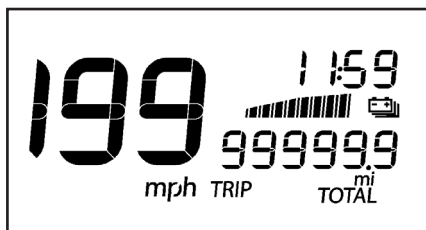
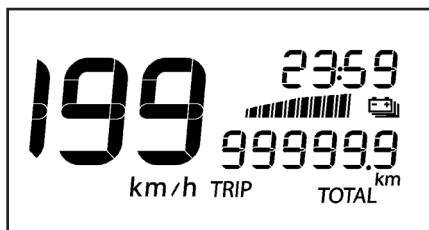

3.2.7 RIDE TIME

Dashboard provides a Ride Time and is displayed on LCD display. Time is obtained from internal crystal quartz and is kept with a push buttons. When the motorbike is turned on the ride time starts again.



3.2.8 UNIT OPTION DISPLAY

Dashboard provides the possibility to change the units and be displayed.

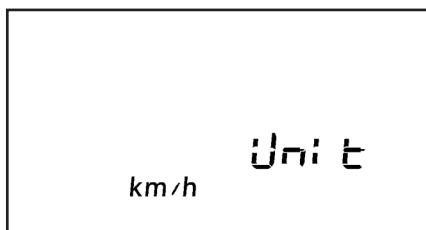
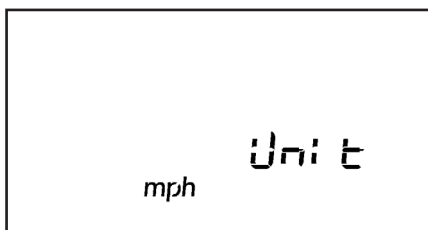

3.2.9 WHEEL LENGTH DISPLAY

Dashboard provides the possibility to change the wheel length and be displayed. The length can be selected between 2 fixed values:

2100mm (enduro)

1811mm

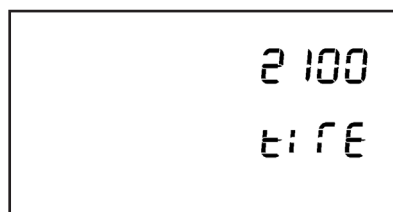
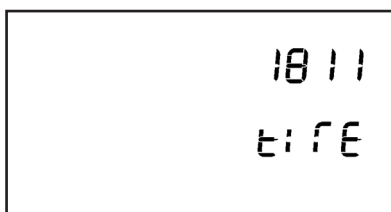

Pushing mode and set more than 2 seconds wheel length is saved. "Saved" will be displayed during 1 second on Dashboard.

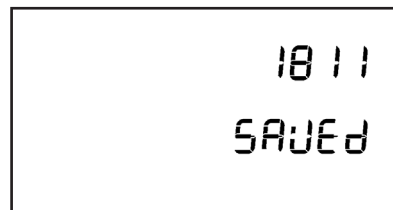

3.2.10 MOTORBIKE BATTERY LEVEL

Dashboard displays level of voltage of battery power supply:
Relationship between bars and level of voltage:

Bars	Voltage [V]	Bars	Voltage [V]
0 → 1	11	4 → 5	13
1 → 2	11.5	5 → 6	13.5
2 → 3	12	6 → 7	14
3 → 4	12.5	7 → 8	14.5

Battery level is updated every 30 seconds. Each update increase or decrease 1 bar.

**WARNING:**

If the word "HIGH" appears with the battery indicator flashing, turn off the engine and disconnect the battery as described on page 68.

Contact authorised BETAMOTOR customer service.

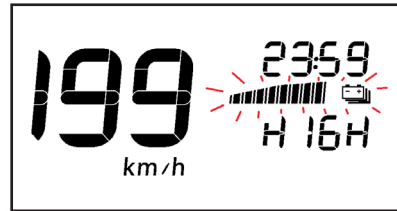

3.2.11 PUSH BUTTON MANAGEMENT TABLE

Mode	Speed	Function	Button	Time (sec)	Activity
ODO			MODE	<2	TOTAL- TRIPA - TRIPB - TOTAL
			SET	<2	Ride time- km – Ride time
	0	CLOCK MODE	MODE&SET	>2	CLOCK MODE
	0	WHEEL LENGTH	MODE	>10	WHEEL LENGTH MODE
	0		SET	>10	Km/h - mph - Km/h
TRIPA			MODE	<2	TRIPA - TRIPB - ODO - TRIPA
			SET	<2	Ride Time- Km– Ride time
			SET	>2	Reset Trip A and Ride time
	0	CLOCK MODE	MODE&SET	>2	CLOCK MODE
TRIPB			MODE	<2	TRIPB - ODO – TRIPA - TRIPB
			SET	<2	Ride Time- Km– Ride time
			SET	>2	Reset Trip A and Ride time
	0	CLOCK MODE	MODE&SET	>2	CLOCK MODE

Mode	Speed	Function	Button	Time (sec)	Activity
CLOCK MODE	0	"On Entering Stop Clock Mode"	MODE	<2	Increase in the Hour digits
			MODE	>2	Speedy increase in the Hour digits
			SET	<2	Increase in the minutes digits
			SET	>2	Speedy increase in the minutes digits
			MODE&SET	>2	Exit clock set mode and save the value
			NO ACTION	>10	Auto exit without saving

Mode	Speed	Function	Button	Time (sec)	Activity
WHEEL LENGTH	0	On entering wheel length mode	MODE	<2	Change wheel 2100 – 1811
			MODE&SET	>2	Exit wheel length mode and save the value
			NO ACTION	>10	Auto exit without saving



2

3.3 TELLTALES

LED number indicator:



Telltale/Indicator lights specifications:

Number of telltales: 4

LED number	Function	Symbol
LED 1	Blinkers	
LED 2	High beam	
LED 3	Fuel Reserve	
LED 4	MIL telltale (Engine management system fault)	

Power +12V are provided to the dashboard only when the bike is turned on (regulator line).

Blinkers LED 

The system activates the indicator in synchrony with the activation of the direction indicators

High beam LED 

The system activates the indicator in synchrony with the activation of the high beam.

Reserve LED 

MIL LED 

Indicates a fault in the engine management system. In case of prolonged lighting, consult an authorised Betamotor dealer as soon as possible.

4 COIN BATTERY

Dashboard is equipped with a coin battery (1) for keeping time when motorbike is off. Coin size: CR2032.

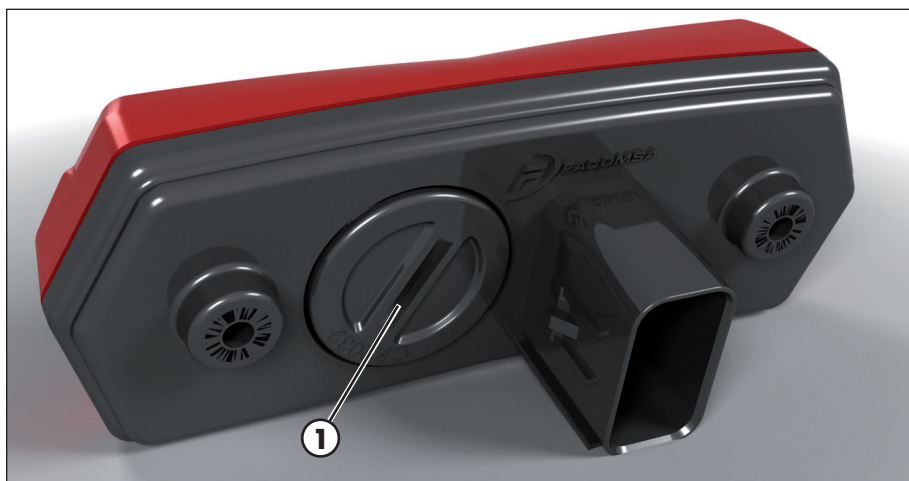

2

CHECKS BEFORE AND AFTER USE

For safe driving and long vehicle life you should:



1 Check all fluid levels.



2 Check the correct operation of the brakes and brake pad wear (page 54).



3 Check pressure, general condition and thickness of tread.

4 Check that the spokes are properly tightened.

5 Check the tensioning of the chain (page 65).



6 Check the adjustment and the operation of all the cable controls.



7 Inspect all the nuts and bolts.

8 With the engine running, check the operation of the headlight, the rear and brake lights, the indicators, the warning lights and the horn.

9 Wash the motorcycle thoroughly after off-road use (page 71).

OPERATION

RUNNING IN

The running-in period lasts approximately 15 hours, during which it is advisable to:

- 1 During the first 3 hours of operation the engine should only be used to approximately 50 percent of its power. In addition, the engine speed should not exceed 7,000 rpm.
- 2 For the next 12 hours of operation the engine should only be used to about 75 percent of its power.

WARNING

After the first 3 hours change the engine and gear oil.

This procedure should be followed each time piston, piston rings, cylinder, crankshaft or crankshaft bearings are replaced.

FUELLING

Use unleaded petrol (gasoline).

Disconnect the ventilation pipe **1**.
To open the tank turn the cap **2** anticlockwise.

To close the fuel tank's cap, set it on the tank and crew it clockwise.

Fuel tank capacity is shown on page 10.

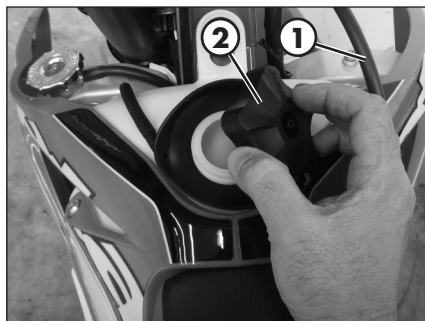

WARNING:

The refuelling should be performed with the engine off.

When the operation is finished, reconnect the ventilation pipe.



WARNING:

Fire hazard. Fuel is highly flammable.



Always stop the engine when refuelling and keep open flames and lighted cigarettes away.



Do not top up fuel while using a mobile phone.

Refuel in an open well ventilated area.

Pay special attention so that the fuel does not come into contact with hot parts of the vehicle. Immediately clean up any spilled fuel.



WARNING: Risk of poisoning.

Fuel is poisonous liquid and a health hazard.



Fuel must not come into contact with the skin, eyes, and clothing. Do not breathe in the fuel vapours. If contact occurs with the eyes, rinse immediately with plenty of water and seek medical advice. If contact occurs with skin, immediately clean contaminated areas with soap and water. If fuel is swallowed, contact a doctor immediately. Change clothing that is contaminated with fuel.

WARNING: Environmental pollution hazard.

The fuel must not contaminate the ground water, the ground, or the sewage system.

2

STARTING THE ENGINE

The bike starts ONLY with the battery mounted on the vehicle and connected to the electrical system.

Check that the gears are in neutral (page 17).

Close the side stand (page 18).

WARNING:

During start-up it is advisable not to operate the throttle.

WHIT ELECTRIC STARTER (page 16):

Press the startup button for a max of 3 seconds. If the vehicle does not startup, wait 30 seconds before attempting a new startup.

NOTE

Pauses are needed to diffuse the generated heat and to avoid damaging the battery. If the battery is at a temperature below 15°C, the electric startup will be weak, not because the battery is deteriorated but because it needs to be warmed up. Therefore, with temperatures below 15°C, several startup attempts may be necessary to heat the battery and thereby increase the battery power provided by the battery.

Do not press the button while the engine is running.

NOTE: If the battery charge is not sufficient to allow the electric starter you can still start the bike with the start lever if the battery voltage is more than 8V.

WITH KICK-STARTER (page 17):

Depress the kick-starter with a sharp movement of the foot.

In case of cold start with kick starter it is required to act on the starting lever for about three times.

WARNING:

Do not try to start the engine by combining the effect of the kick starter and the electric starter.

ENGINE SHUT-DOWN

To shut-down the engine press the button  on the switch unit (page 16).

WARNING:

In case of fall the vehicle turns off after about 5 seconds.

VEHICLE PREPARATION FOR USE IN HEAVY-DUTY CONDITIONS

Using the vehicle in heavy-duty conditions, such as sand or wet or muddy soils, may require the corrective actions mentioned below.

The following are considered heavy-duty operating conditions:

- Dry sand
- Wet sand
- Particularly wet and muddy soils
- Driving in high temperature and low speed conditions
- Driving in low temperature and snow conditions

General actions:

- Verify filter and filter box cleaning (page 49)
- Verify tensioning and wear of the chain (page 66)
- Verify all electrical connectors, making sure they are well connected. Keep them dry and clean.

USE ON DRY SAND

- Apply specific protection against sand to the air filter
- Clean the chain
- Assemble a steel crown. For this operation contact the Betamotor service network. (Do not grease the chain!)
- Verify that the radiator fins are clean
- Verify that the radiator fins are not bent

USE ON WET SAND

- Apply an anti-water cap for the water filter
- Clean the chain
- Assemble a steel crown. For this operation, contact the Betamotor service network. (Do not grease the chain!)
- Verify that the radiator fins are clean
- Verify that the radiator fins are not bent

USE ON PARTICULARLY WET AND MUDDY SOILS

- Apply an anti-water cap for the water filter
- Assemble a steel crown. For this operation contact the Betamotor service network.
- Verify that the radiator fins are clean
- Verify that the radiator fins are not bent
- After use, proceed with washing (page 71)

DRIVING IN HIGH TEMPERATURE AND LOW SPEED CONDITIONS

- Adjust crown size based on the route.
Note: The oil has a tendency to heat up quickly when there is frequent clutch use and when using a crown whose dimensions are excessive. For this operation contact the Betamotor service network.
- Clean the chain
- Verify that the radiator fins are clean
- Verify that the radiator fins are not bent
- Verify cooling liquid level (page 47)
- For this use it is recommended to use an electric fan (optional). For the code, refer to the Betamotor accessory catalogue.

DRIVING IN LOW TEMPERATURE AND SNOW CONDITIONS

- Apply water protection to the air filter
- After use, proceed with washing (page 71)

CHAPTER 3 ADJUSTMENTS

CONTENTS

Key to symbols.....	36
Brakes	36
Front brake	36
Rear brake	36
Clutch.....	36
Adjustment of gas clearance.....	37
Idle adjustment	37
Handlebar adjustment	37
U-bolt position adjustment.....	37
Adjustment of the handlebar position	38
Adjusting fork.....	39
Adjusting the rebound damper	39
Adjusting the compression damper	39
Shock absorber.....	39
Adjusting the rebound damper	39
Adjusting the hydraulic compression damper (high and low speeds)	40
Adjusting the spring preload	40
Static sag load test	41
Suspensions settings according to the weight of the rider.....	42

KEY TO SYMBOLS



Tightening torque



Threadlocker Medium

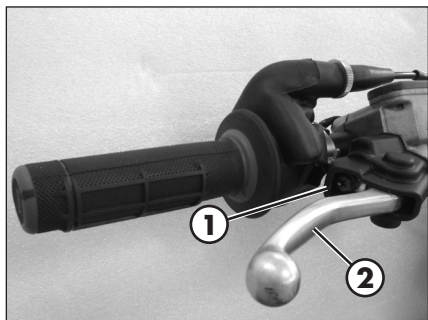

BRAKES

FRONT BRAKE

The front brake is disk type with hydraulic control.

The home position of brake lever **2** can be adjusted by means of screw **1**.

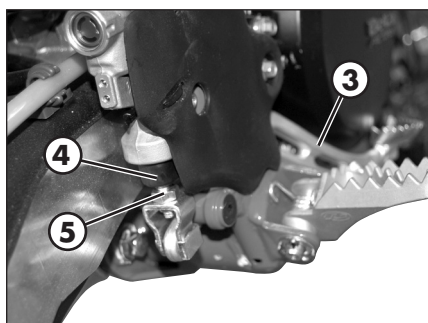

REAR BRAKE

The home position of brake pedal **3** can be altered by turning adjusting screw **5** after loosening the counternut located under dust cap **4**. Loosen the counternut and turn the adjusting screw until the desired height is obtained. Retighten the counternut after completing the operation.

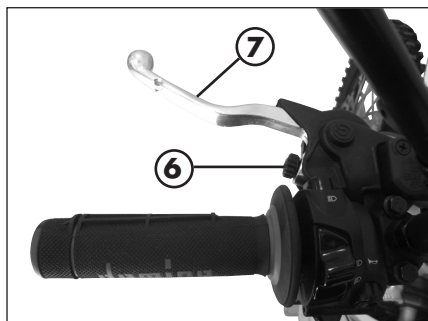

CLUTCH

The adjustment screw **6** allows adjustment of the distance of lever **7** from the knob. The empty run is recovered automatically.

ADJUSTMENT OF GAS CLEARANCE

The throttle control cable should always have a 3-5 mm play. In addition, the idle speed should not change when the handlebars are fully rotated to the left or right. Push back protective cap **1**. Loosen counternut **2** and turn adjusting screw **3**. Tighten the counternut and check that the throttle twist grip turns smoothly.

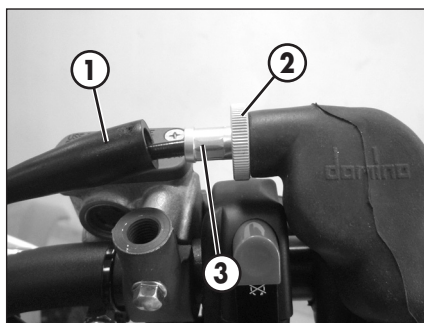

IDLE ADJUSTMENT

The minimum speed is controlled directly by the electronic control unit. Any manual adjustment is not allowed.

 **WARNING!** Do not modify the indicated screw for any reason. Modifying the position of this screw may cause abnormal response behaviour and engine operation. Moving the indicated screw, in terms of the warranty, is considered tampering.

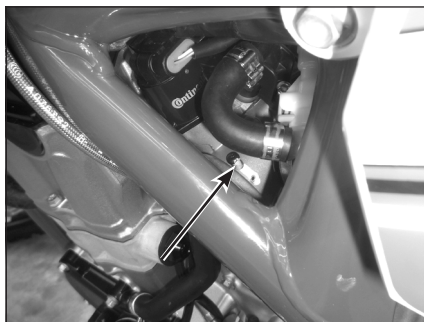

HANDLEBAR ADJUSTMENT

U-BOLT POSITION ADJUSTMENT

The lower bracket **1** can be mounted on the holes nr. **2**, **3** or **4** respectively.

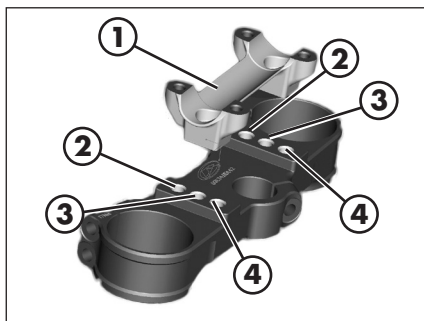

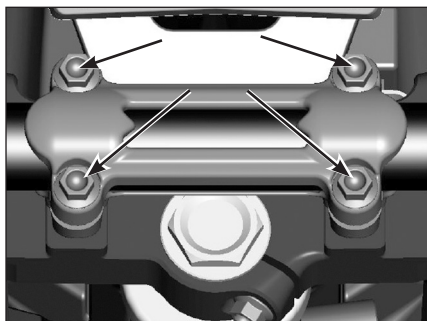

To adjust the position of the u-bolt remove the screws shown in the figure.

Remove the handlebar.

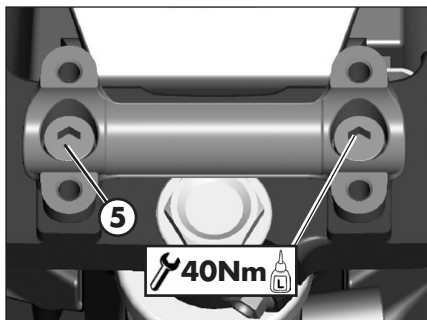

Remove the screws **5**.

NOTE: Before removing the screws **5** heat the area with a hairdryer of the type used by coachbuilders.

Position the U-bolt as required.

At the end refit the screws **5** after the application of thread lock fluid and tighten to the torque indicated.

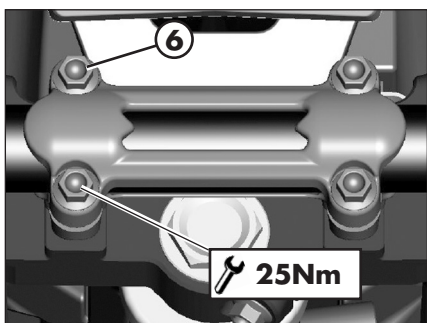

Apply the handlebar.

Apply the top u-bolt.

Refit the screws **6**. Tighten to the torque indicated.

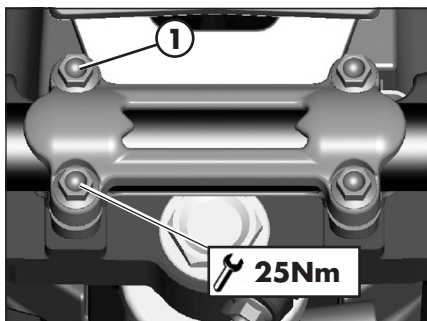

ADJUSTMENT OF THE HANDLEBAR POSITION

The handlebar can be adjusted by rotating it back and forth.

To adjust the handlebar loosen screws **1**.

Position the handlebar according to requirements.

Tighten to the torque indicated.

ADJUSTING FORK

ADJUSTING THE REBOUND DAMPER

The hydraulic rebound damper determines the behaviour of the telescopic fork during extension and can be adjusted by means of screw **A**. Turning the screw clockwise increases the action of the rebound damper; turning it anticlockwise decreases the action of the rebound damper.

For standard calibration, refer to page 11.



ADJUSTING THE COMPRESSION DAMPER

The hydraulic compression damper determines the behaviour of the telescopic fork during compression and can be adjusted by means of screw **B** located at the lower end of the fork legs. Turning the screw clockwise increases the action of the compression damper; turning it anticlockwise decreases the action of the compression damper.

For standard calibration, refer to page 11.

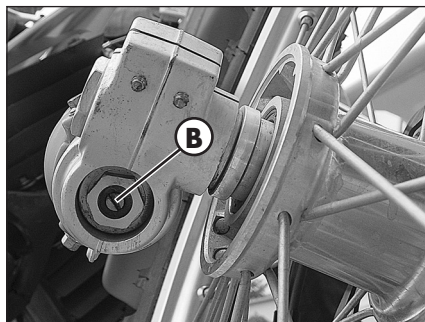

SHOCK ABSORBER

ADJUSTING THE REBOUND DAMPER

Turn screw **A** to adjust the hydraulic rebound damper.

Turning the screw anticlockwise (out) decreases the damping effect.

For standard setting, refer to page 11.

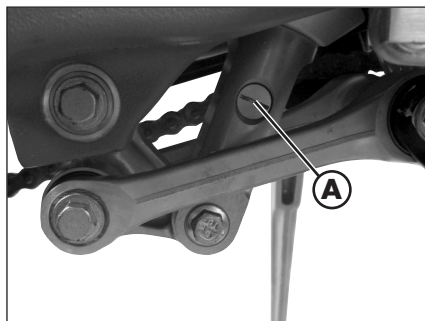

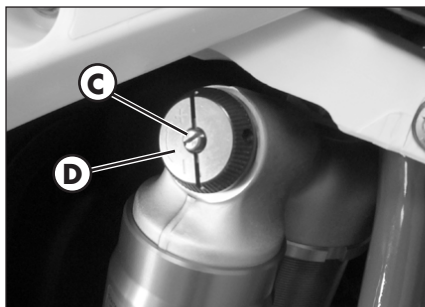

ADJUSTING THE HYDRAULIC COMPRESSION DAMPER (HIGH AND LOW SPEEDS)

Adjustment for low compression speed:

- Using a screwdriver, loosen screw **C** by turning it clockwise to increase the hydraulic compression damper.

For standard setting, refer to page 11.

Adjustment for high compression speed:

- Turn knob **D** anticlockwise to decrease the hydraulic compression damper.

For standard setting, refer to page 11.

WARNING:

Starting from the standard position, turn the knob anticlockwise (with a closing action), the center screw will have an integral movement, then will rotate with the knob.

For standard setting, refer to page 11.

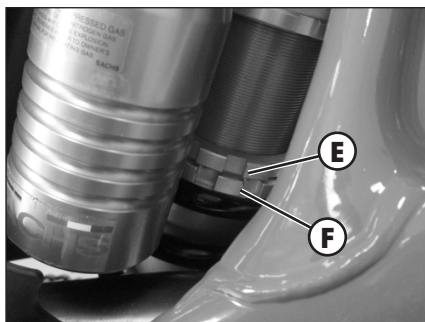

ADJUSTING THE SPRING PRELOAD

Loosen counter-ring **E**, rotate ring **F** clockwise to increase the spring preload (and consequently the shock absorber preload) or anticlockwise to decrease it. After obtaining the desired preload, turn counter-ring **E** until it stops against adjusting ring **F**.

For standard setting, refer to page 11.

NOTE: for the handling of ring nuts use the specific wrench provided in the standard tool kit shown in the figure.



STATIC SAG LOAD TEST

To verify the static sag of the shock absorber proceed as follows:

- Place the motorcycle on the work stand.
- Measure the vertical distance between the rear wheel axle and a reference point on the rear fairings.
- Write down the dimension H_1 .
- Remove the work stand.
- Keep the motorcycle in vertical position and measure again the distance between the wheel axle and the reference point previously established.
- Write down the dimension H_2 .

Verify that the value of the static compression $X = H_1 - H_2$ matches the one shown on page 11. Otherwise, perform the adjustment of the spring preload as described above.

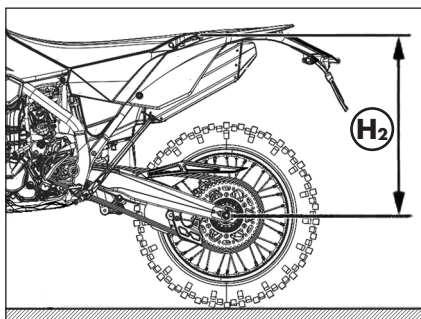
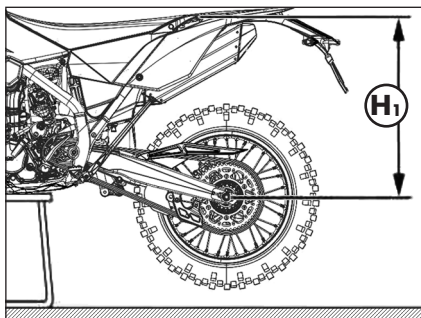

3

SUSPENSIONS SETTINGS ACCORDING TO THE WEIGHT OF THE RIDER

The table below shows the spring constant K of the suspensions (fork and shock absorber) depending on the weight of the driver.

Refer to the accessories catalogue Betamotor to obtain the spring codes.

Fork	
Rider weight [kg]	K (Spring constant)
< 55	4,2
55 - 70	4,6
70 - 85	4,8
> 85	5

Shock absorber	
Rider weight [kg]	K (Spring constant)
< 50	4,8
50 - 60	5
60 - 70	5,2
70 - 80	5,4
80 - 95	5,6
> 95	5,8

 Standard settings

CHAPTER 4 CHECKS AND MAINTENANCE

CONTENTS

Engine oil.....	44
Check the level	44
Replacement	44
Gearbox oil	46
Check the level	46
Replacement.....	46
Liquid coolant.....	47
Check the level	47
Replacement.....	48
Air filter	49
Air filter cleaning	50
Spark plug	51
Front brake.....	52
Check the level of the front brake fluid	52
Restoring the level of the front brake fluid	52
Bleeding the front brake	53
Front brake lining control	54
Brake disc thickness control	54
Rear brake.....	55
Check the level of the rear brake fluid.....	55
Restoring the level of the rear brake fluid	55
Bleeding the rear brake	56
Rear brake lining control.....	57
Brake disc thickness control	57
Clutch control	58
Check the level	58
Bleeding	59
Check and adjusting of steering play.....	60
Oil fork.....	61
Removing legs	61
Oil replacement	61
Legs assembly and parts	63
Rear suspension leverage.....	64
Tyres.....	65
Chain	65
Check and adjust tightening chain	65
Check for chain wear	66
Headlight.....	67
Replacing the headlight bulbs	67
Tail light.....	67
Battery.....	68
Battery removal.....	68
Battery assembly.....	69
Inactivity	69
Charging the battery	70
Fuses	70
Cleaning the vehicle.....	71
General precautions.....	71
Electrical connector maintenance	72
Control unit connector.....	72
Air pressure and temperature sensor.....	73
Prolonged inactivity.....	74
Scheduled maintenance vehicle	75
Tightening torque overview	77

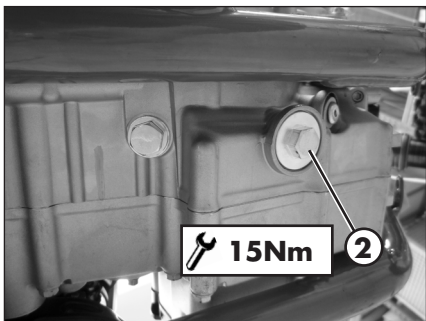
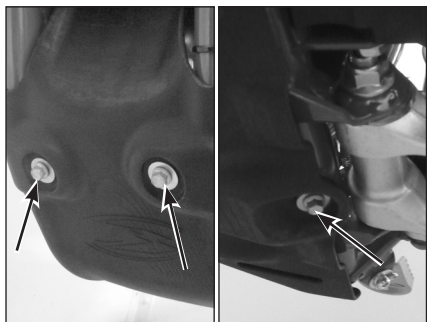
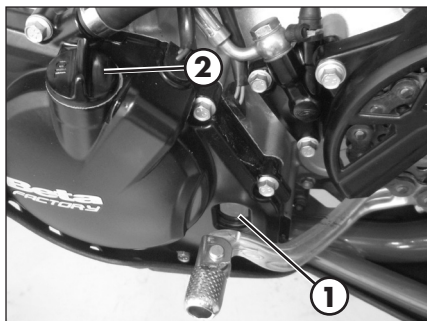

ENGINE OIL

CHECK THE LEVEL

When engine is cold check the oil level by means of porthole **1**. The oil level must be always visible from the porthole.

In contrary case restore the oil level through cap **2** up to the upper edge of the inspection window.

Use the oil indicated on page 13 in the "Recommended lubricants and liquids" table.

REPLACEMENT

Always perform the replacement when engine is hot:

- Position the drive on a flat base ensuring stability.
- Remove the engine casing by loosening the screws shown in the figure.
- Place a container under the engine.



WARNING:

Hot oil can cause severe burns!

- Unscrew filler plug **1** and drain plug **2**.
- Remove the wire mesh filter.
- Drain all the oil from the crankcase.
- Thoroughly clean the drain plug, the wire mesh filter and the sealing surfaces.

- Mount the wire mesh filter and the drain plug.
- Tighten to the torque indicated.

To change the paper filter, remove the oil tap form engine unscrewing the two screws **3**. Using special seeger ring pliers, pull the paper oil filter.

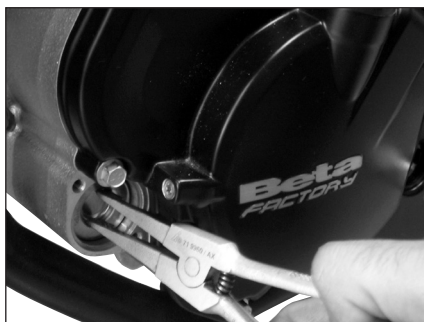
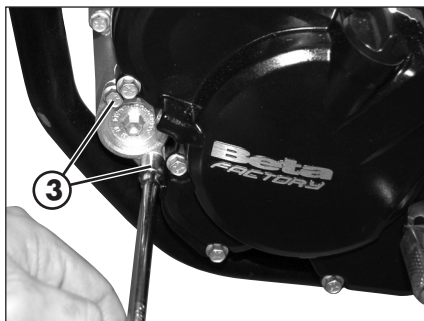

Mount the new paper filter, close the oil tap to engine, tighten the screws at 10 Nm.

Pour in the quantity of liquid indicated on page 10.

Use the oil indicated on page 13 in the "Recommended lubricants and liquids" table.

- Screw on filler cap **1** again.
- Start the engine and run at idle for a few minutes.
- Turn off the engine and wait for about one minute, then check the level and top up if needed, without exceeding the upper edge of the inspection window.

WARNING:

Hot oil can cause severe burns!

ATTENTION:

Dispose of used oil in compliance with the regulations in force.

Re-assemble the engine protection plate by tightening the screws to 10Nm.

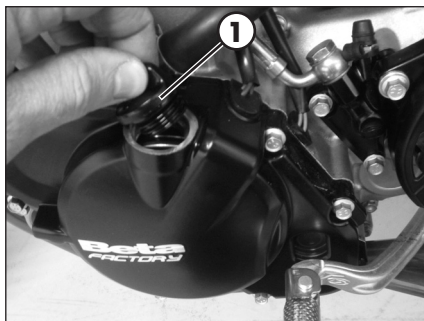
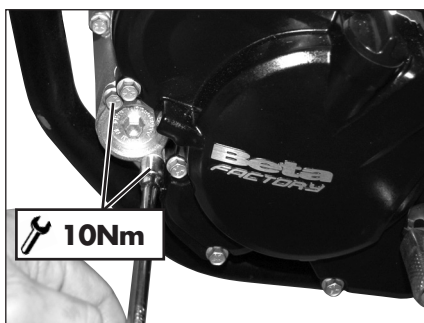

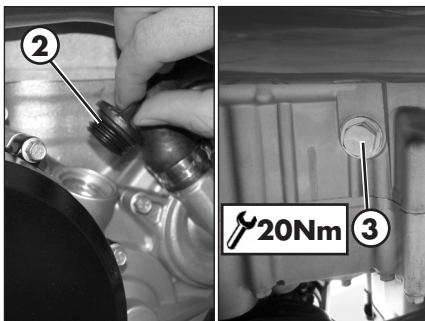
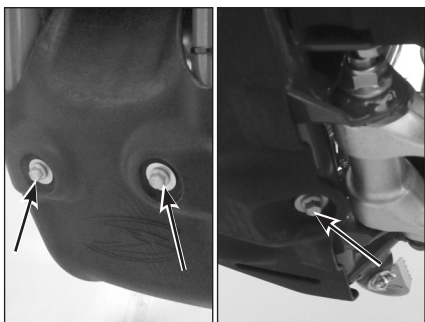
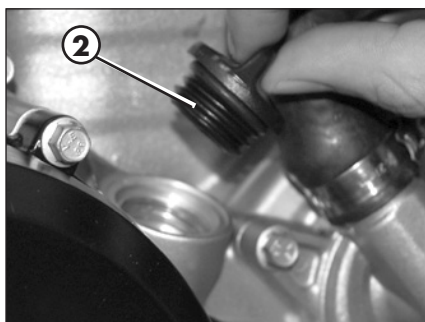
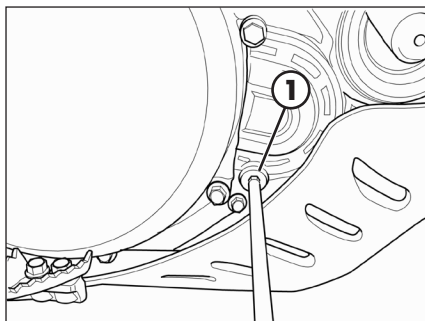

GEARBOX OIL

CHECK THE LEVEL

Hold the vehicle upright.
Position the drive on a flat base ensuring stability.

Remove the inspection cap **1**.

The oil level must arrive to the lower edge of check hole.

In contrary case restore the oil level through cap **2**.

Use the oil indicated on page 13 in the "Recommended lubricants and liquids" table.

REPLACEMENT

Always perform the replacement when engine is hot:

- Position the drive on a flat base ensuring stability.
- Remove the engine casing by loosening the screws shown in the figure.
- Place a container under the engine.

⚠ WARNING:
Hot oil can cause severe burns!

- Unscrew filler plug **2** and drain plug **3**.
- Drain all the oil from the crankcase.
- Apply the cap **3** and tighten up to the specified torque.

Pour in the quantity of liquid indicated on page 10.

Use the oil indicated on page 13 in the "Recommended lubricants and liquids" table.

Close plug **2**.

WARNING:

Hot oil can cause severe burns!

ATTENTION:

Dispose of used oil in compliance with the regulations in force.

Re-assemble the engine protection plate by tightening the screws to 10Nm.

LIQUID COOLANT

CHECK THE LEVEL

Keep the vehicle in vertical position relative to the ground.

The level of the coolant must be checked when the engine is cold. Use the following procedure:

- Unscrew cap **1** and ensure that the liquid is visible in the lower portion of the load-ing tube.
- In the case in which the liquid is not visible remove the vent screw **2** and proceed topping up.
- At the end of operation refit the filler cap and the vent screw.

Use the oil indicated on page 13 in the "Recommended lubricants and liquids" table.

 **WARNING:** Never unscrew the filler cap of the radiator when the engine is hot. Danger of burning!

 **WARNING:**
Wear appropriate protective clothing and protection gloves.

 Keep coolant out of reach of children.

 Avoid any direct contact of the coolant with skin, eyes or clothing. If this happens:

- with the eyes, rinse immediately with plenty of water and seek medical advice;
- with skin, Immediately clean contaminated areas with soap and water Change clothing that is contaminated with coolant.

If coolant is swallowed, contact a doctor immediately.

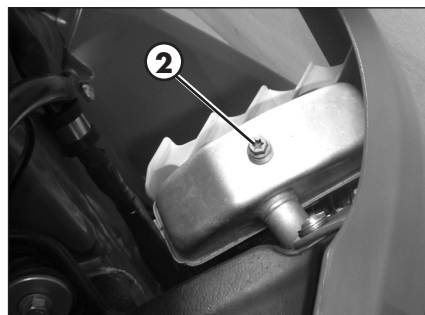
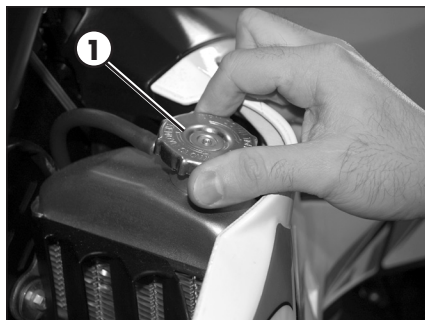
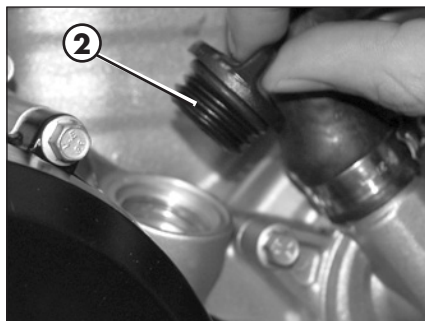

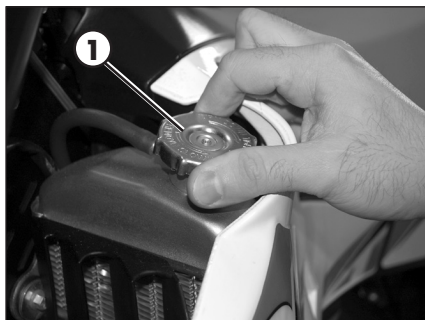
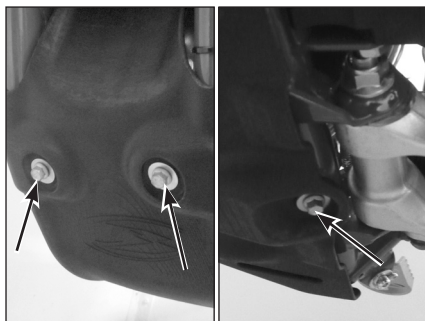

REPLACEMENT

Keep the vehicle in vertical position relative to the ground.

Replacement of the coolant must take place when the engine is cold.

- Remove the engine casing by loosening the screws shown in the figure.

- Unscrew cap **1**.

- Place a container under screw **2**.

- Unscrew the screw **2**.

- Drain the liquid.

- Tighten screw **2** applying the specific washer.

- Re-assemble the engine protection plate by tightening the screws to 10Nm.

- Unscrew drain screw **3**.
- Proceed to filling.
- Reapply the loading cap and the bleeding screw.

The amounts of liquid are shown on page 10.

Use the liquid indicated on page 13 in the "Recommended lubricants and liquids" table.

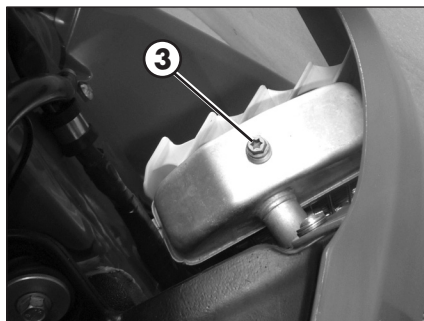

WARNING:

Never unscrew the filler cap of the radiator when the engine is hot. Danger of burning!



WARNING:

Never unscrew the filler cap of the radiator when the engine is hot. Danger of burning!



WARNING:

Wear appropriate protective clothing and protection gloves.



Keep coolant out of reach of children.



Avoid any direct contact of the coolant with skin, eyes or clothing. If this happens:

- with the eyes, rinse immediately with plenty of water and seek medical advice.
- with skin, Immediately clean contaminated areas with soap and water Change clothing that is contaminated with coolant.

If coolant is swallowed, contact a doctor immediately.

AIR FILTER

Check after every ride.

To access the filter:

- Remove the saddle (page 80).
- Unhook the filter cover panel by pulling it outward.

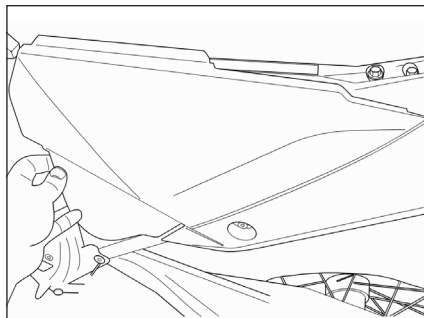

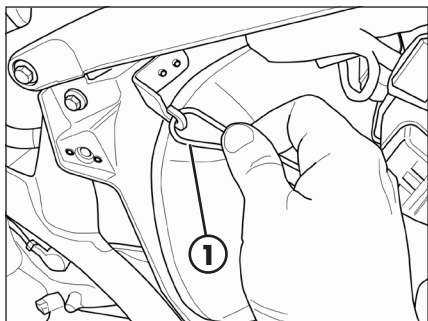

- Release filter fastener **1**

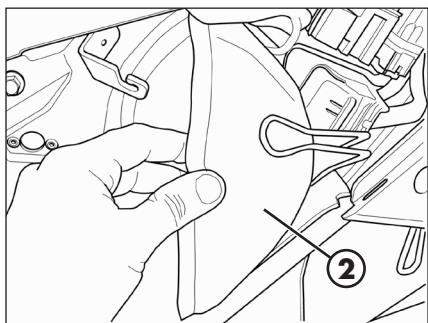

- Pull out air filter **2**

 **WARNING:**
After every intervention, check that nothing has been left inside the filter box.

Reassemble by performing the operations in reverse order.

AIR FILTER CLEANING

- Thoroughly wash the filter with water and soap.
- Dry the filter.
- Wet the filter with filter oil and then remove the excess oil to prevent it from dripping.
- If necessary also clean the interior of the filter box.

 **WARNING:**
Do not clean the filter with gasoline or petrol.

 **NOTE:**
If the filter is damaged, replace it immediately.
To replace, contact authorised Betamotor customer service.

 **WARNING:**
Never use the vehicle if the air filter is not in place. The infiltration of dust and dirt can cause damage and considerable wear.

 **WARNING:**
After every intervention, check that nothing has been left inside the filter box.

SPARK PLUG

Keeping the spark plug in good condition will reduce fuel consumption and increase engine performance.

To accede to spark plug, is necessary to take off saddle (page 80) and the fuel tank (page 82).

Examine the distance between the electrodes with a feeler. This distance should be from $0,5 \div 0,6$ mm. If it is not, it may be corrected by bending the earth electrode.

Check as well that there are no cracks in the insulation or corroded electrodes. If so, replace immediately.

When replacing the spark plug, screw it in by hand until it stops, then tighten with a wrench.

 **WARNING:**
Do not check while the engine is hot.

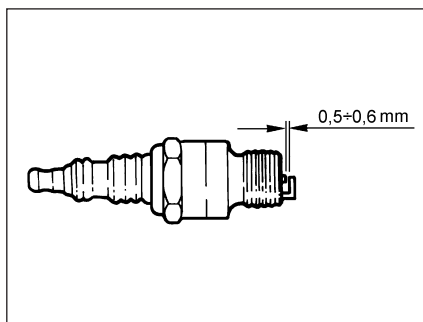

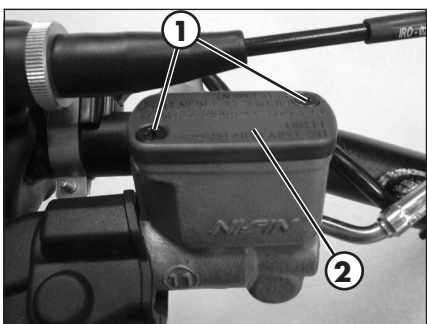
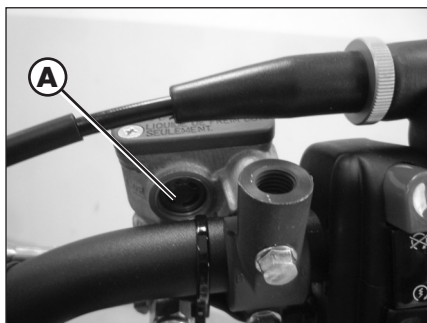

FRONT BRAKE

CHECK THE LEVEL OF THE FRONT BRAKE FLUID

Check the level of the brake fluid through sight **A**. The level of the fluid should never fall below the mark in the sight.

RESTORING THE LEVEL OF THE FRONT BRAKE FLUID

To restore the level of the brake fluid, loosen the two screws **1**, lift cap **2** and add brake fluid until its level is 5 mm below the upper rim of the reservoir.

Use the liquid indicated on page 13 in the "Recommended lubricants and liquids" table.



WARNING:

The brake fluid is extremely corrosive. Take care not to spill it on the paintwork.



Wear appropriate protective clothing and protection gloves.



Keep coolant out of reach of children.



WARNING: Avoid any direct contact of the liquid with skin, eyes or clothing. If this happens:

- with the eyes, rinse immediately with plenty of water and seek medical advice.
- with skin, immediately clean contaminated areas with soap and water. Change clothing that is contaminated with liquid.

If liquid is swallowed, contact a doctor immediately.

BLEEDING THE FRONT BRAKE

To bleed air from the front brake circuit, proceed as follows:

- Remove the rubber cap **1** from the valve **2**.
- Open the sump cap.
- Place one end of a small transparent tube into the valve **2**, and the other end inside a container.
- Pump with the brake lever 2/3 times and keep the lever pressed.
- Unscrew the valve and let the oil drain.
- If air is still visible in the tube repeat above operation until obtaining a continuous outflow of oil within no air bubbles.
- Close the valve and release the lever.

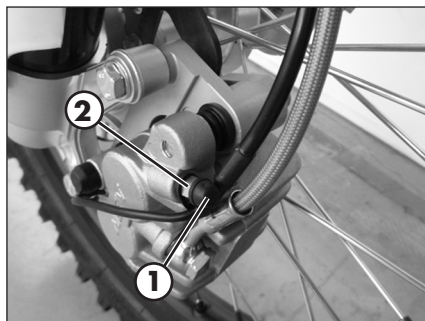

NOTE:

during this procedure, continuously top up the brake pump tank to replace the oil that is out flowing.

- Remove the tube.
- Replace the rubber cap.
- Close the oil reservoir cap.

Use the liquid indicated on page 13 in the "Recommended lubricants and liquids" table.



WARNING:

The brake fluid is extremely corrosive. Take care not to spill it on the paintwork.



Wear appropriate protective clothing and protection gloves.



Keep coolant out of reach of children.



WARNING: Avoid any direct contact of the liquid with skin, eyes or clothing. If this happens:

- with the eyes, rinse immediately with plenty of water and seek medical advice.
- with skin, immediately clean contaminated areas with soap and water. Change clothing that is contaminated with liquid.

If liquid is swallowed, contact a doctor immediately.

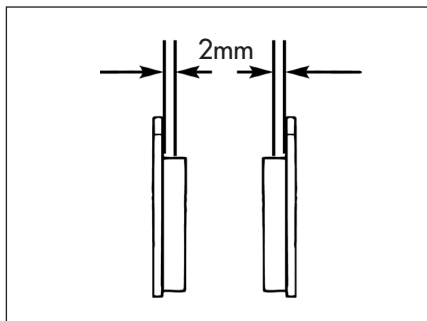

FRONT BRAKE LINING CONTROL

In order to verify the wear condition of front brake is enough to view the caliper from the bottom, where is possible to glimpse the brake lining tails which will have to show a brake of 2 mm in thickness. If the stratum is lesser let's start replacing them.

NOTE:

Perform the check according to the times shown in the table on page 75.

To replace, contact authorised Betamotor customer service.

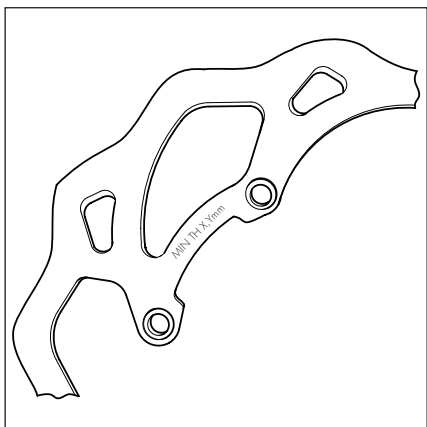

BRAKE DISC THICKNESS CONTROL

Periodically verify disc condition. In case signs of damage, veins, or deformations are present, proceed with replacement. Verify disc thickness. The minimum thickness is engraved on the disc.

Once the limit is in proximity or has been reached, proceed with brake disc replacement.

For replacement, contact an authorised Betamotor after-sales service centre.

REAR BRAKE

CHECK THE LEVEL OF THE REAR BRAKE FLUID

Check the level of the brake fluid through sight **A**. The level of the fluid should never fall below the mark in the sight.

RESTORING THE LEVEL OF THE REAR BRAKE FLUID

To restore the oil level, top up by means of oil filler cap **1**.

Use the liquid indicated on page 13 in the "Recommended lubricants and liquids" table.

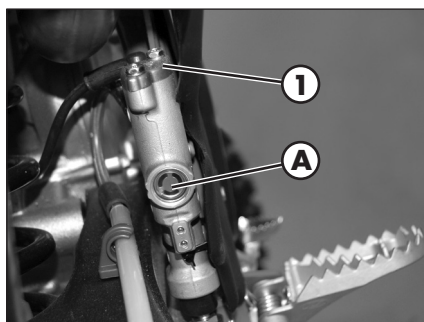

 **WARNING:**
The brake fluid is extremely corrosive. Take care not to spill it on the paintwork.

 Wear appropriate protective clothing and protection gloves.

 Keep coolant out of reach of children.

 **WARNING:** Avoid any direct contact of the liquid with skin, eyes or clothing. If this happens:

- with the eyes, rinse immediately with plenty of water and seek medical advice.
- with skin, immediately clean contaminated areas with soap and water. Change clothing that is contaminated with liquid.

If liquid is swallowed, contact a doctor immediately.

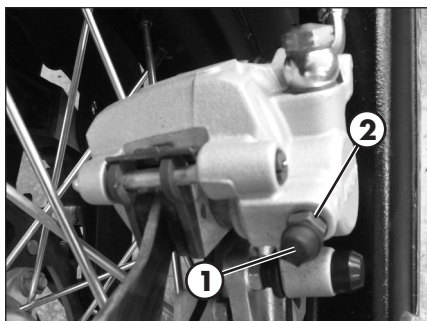

BLEEDING THE REAR BRAKE

To bleed air from the rear brake circuit, proceed as follows:

- Remove the rubber cap **1** from the valve **2**.
- Open the sump cap.
- Place one end of a small transparent tube into the valve **2**, and the other end inside a container.
- Pump with the brake lever 2/3 times and keep the pedal pressed.
- Unscrew the valve and let the oil drain.
- If air is still visible in the tube repeat above operation until obtaining a continuous outflow of oil within no air bubbles.
- Close the valve and release the lever.

NOTE:

During this procedure, continuously top up the brake pump tank to replace the oil that is out flowing.

- Remove the tube.
- Replace the rubber cap.
- Close the oil reservoir cap.

Use the liquid indicated on page 13 in the "Recommended lubricants and liquids" table.



WARNING:

The brake fluid is extremely corrosive. Take care not to spill it on the paintwork.



Wear appropriate protective clothing and protection gloves.



Keep coolant out of reach of children.



WARNING: Avoid any direct contact of the liquid with skin, eyes or clothing. If this happens:

- with the eyes, rinse immediately with plenty of water and seek medical advice.
- with skin, immediately clean contaminated areas with soap and water. Change clothing that is contaminated with liquid.

If liquid is swallowed, contact a doctor immediately.

REAR BRAKE LINING CONTROL

In order to verify the wear condition of front brake is enough to view the caliper from the bottom, where is possible to glimpse the brake lining tails which will have to show a brake of 2 mm in thickness. If the stratum is lesser let's start replacing them.

NOTE:

Perform the check according to the times shown in the table on page 75.

To replace, contact authorised Betamotor customer service.

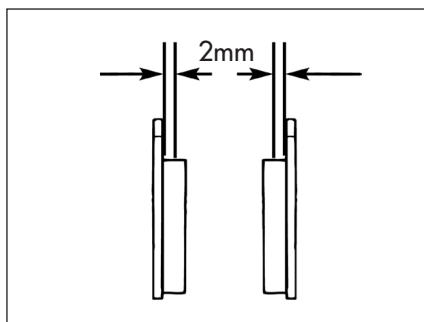

BRAKE DISC THICKNESS CONTROL

Periodically verify disc condition. In case signs of damage, veins, or deformations are present, proceed with replacement. Verify disc thickness. The minimum thickness is engraved on the disc.

Once the limit is in proximity or has been reached, proceed with brake disc replacement.

For replacement, contact an authorised Betamotor after-sales service centre.

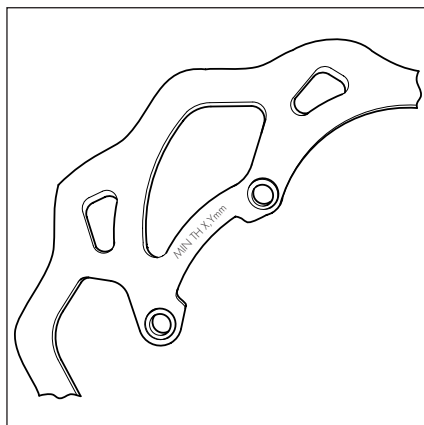

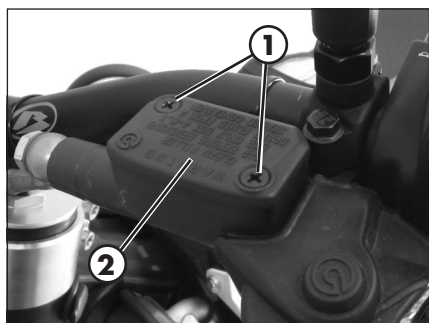

CLUTCH CONTROL

CHECK THE LEVEL

To check the oil level in the clutch pump, first remove cover **2**.

Remove the two screws **1** and take off cover **2** together with the rubber bellows. With the clutch pump in a horizontal position, the level of the oil should be 5 mm below the upper rim.

In the case where the level is lower than specified top up.

Use the liquid indicated on page 13 in the "Recommended lubricants and liquids" table.



WARNING:

The clutch fluid is extremely corrosive. Take care not to spill it on the paintwork.



Wear appropriate protective clothing and protection gloves.



Keep coolant out of reach of children.



WARNING: Avoid any direct contact of the liquid with skin, eyes or clothing. If this happens:

- with the eyes, rinse immediately with plenty of water and seek medical advice.
- with skin, immediately clean contaminated areas with soap and water. Change clothing that is contaminated with liquid.

If liquid is swallowed, contact a doctor immediately.

BLEEDING

To bleed air from the clutch pump, proceed as follows:

- Remove the rubber cap **1** from the valve **2**.
- Open the sump cap.
- Place one end of a small transparent tube into the valve **2**, and the other end inside a container.
- Pump with the clutch lever 2/3 times and keep the lever pressed.
- Unscrew the valve and let the oil drain.
- If air is still visible in the tube repeat above operation until obtaining a continuous outflow of oil within no air bubbles.
- Close the valve and release the lever.

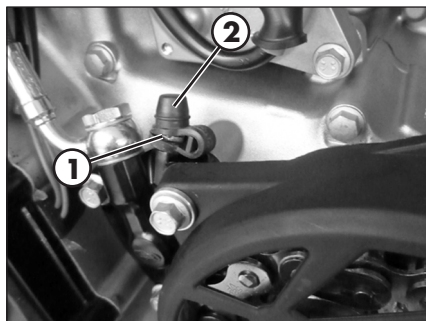

NOTE:

During this procedure, continuously top up the pump tank to replace the liquid that is out flowing.

- Remove the tube.
- Replace the rubber cap.

Use the liquid indicated on page 13 in the "Recommended lubricants and liquids" table.



WARNING:

The clutch fluid is extremely corrosive. Take care not to spill it on the paintwork.



Wear appropriate protective clothing and protection gloves.



Keep coolant out of reach of children.



WARNING: Avoid any direct contact of the liquid with skin, eyes or clothing. If this happens:

- with the eyes, rinse immediately with plenty of water and seek medical advice.
- with skin, immediately clean contaminated areas with soap and water. Change clothing that is contaminated with liquid.

If liquid is swallowed, contact a doctor immediately.

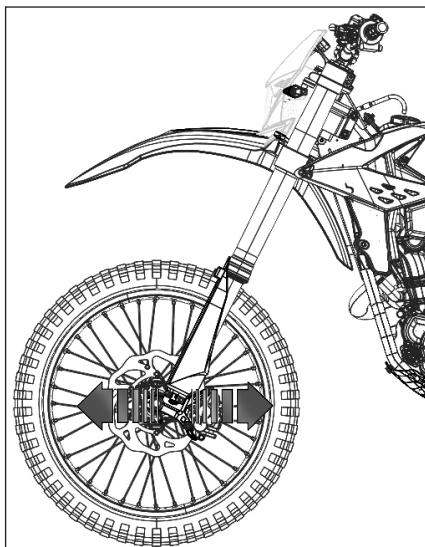

CHECK AND ADJUSTING OF STEERING PLAY

Periodically check the play in the steering sleeve by moving the fork back and forth as shown in the figure. Whenever you feel play, adjust as described below:

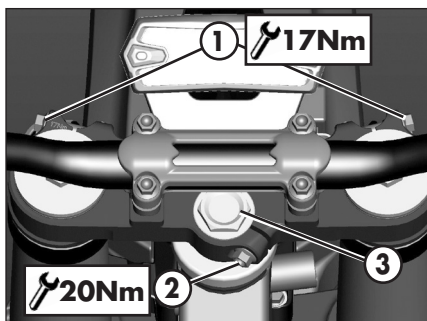

- Loosen the screws **1**
 - Loosen the screw **2**
 - Reduce the play by turning nut **3**
- Tighten the screws to the prescribed torque values.

! **WARNING:**
Tightening of the screws should be carried out by adjusting the torque wrench to the stability torque with repeated tightening until stability torque has been achieved.

OIL FORK

The procedure for changing the oil in the forks is provided only for information.

We recommend having the operation performed by a BETAMOTOR authorized workshop.

REMOVING LEGS

To replace, proceed as follows:

- Position the vehicle on the central bike stand.
- Remove the cable gland U-bolt **1**.
- Remove the brake caliper **2**.
- Remove cap **3**, loosen the screws **4**, slide the wheel pin out and remove the front wheel.
- Loosen shaft lock screws **5** and take off the slider.



OIL REPLACEMENT

- Place the legs vertically with cap **1** facing upwards. Loosen the upper cap **1**.



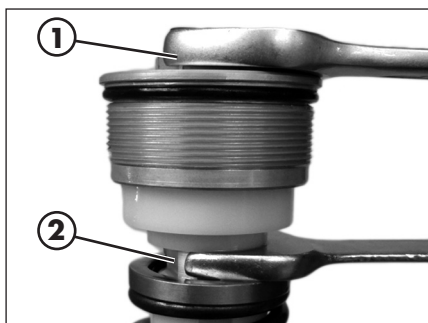

- Loosen the counter-nut **2** and remove cap **1**.

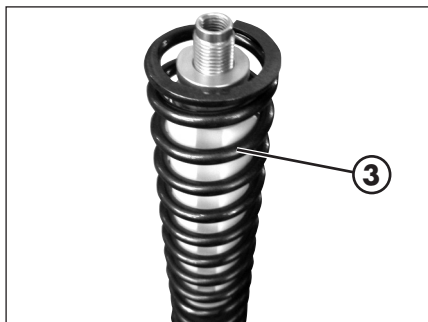

- Extract the spring **3** and overturn the pipe, making the oil escape.



- Move the pumping unit and drain the remaining oil. When the oil has been drained completely, introduce the amount of new oil described in chapter 1.

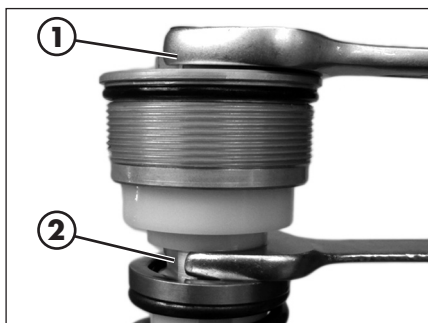

- Bleed the pumping unit of air, making it rise and fall until complete loading. Introduce the spring and screw the cap **1** until it is completely inserted on the pumping rod. Block the cap to the pumping rod via the counter-nut **2**.

- Tighten the cap to the completely extended leg.



LEGS ASSEMBLY AND PARTS

Apply the legs to the vehicle and tighten the screws to the torque indicated.

WARNING:
grease the screws before their application.

- !** **WARNING:**
Tightening of the screws should be carried out by adjusting the torque wrench to the stability torque with repeated tightening until stability torque has been achieved.

Apply wheel and wheel bolt.

Apply brake caliper, disc cover and fender.

Tighten brake calliper and U-bolt to the indicated torque, after depositing medium resistance threadlocker.

Place the vehicle on the ground.



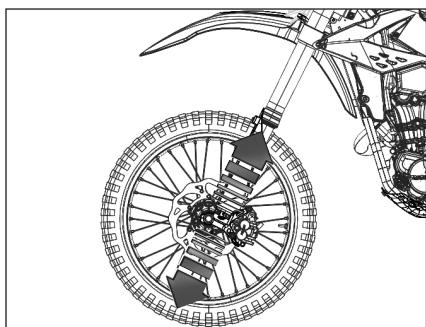

Compress and release the fork 3-4 times.

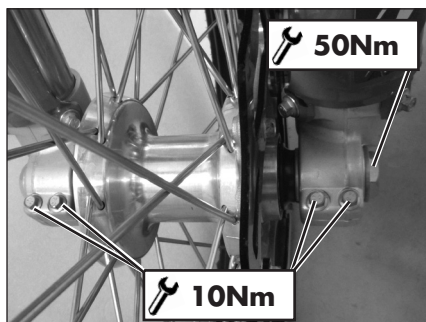

Tighten the wheel bolt and the screws of the foot-leg.

⚠ WARNING:
Tightening of the screws should be carried out by adjusting the torque wrench to the stability torque with repeated tightening until stability torque has been achieved.

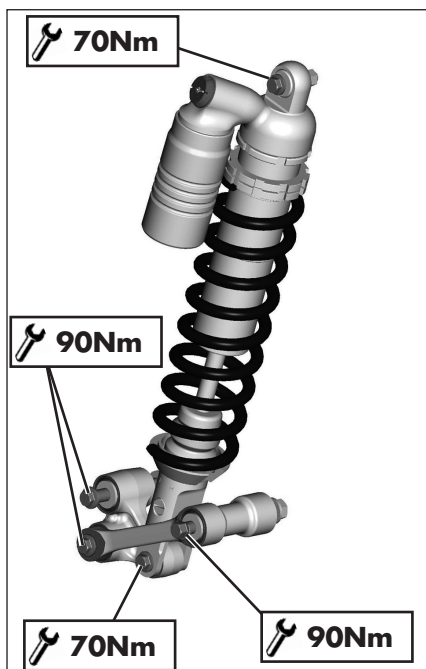

REAR SUSPENSION LEVERAGE

In order to guarantee optimal operation and duration over time of the progressive leverage of the rear suspension, it is recommended to periodically check correct tightness of nuts and bolts.

Verify that suspension nuts and bolts are at the indicated torque.

TYRES

Only fit tyres approved by BETAMOTOR.

Unsuitable tyres can adversely affect the road holding of the vehicle.

- To protect your safety, immediately replace any damaged tyres.
- Slick tyres adversely affect the road holding of the vehicle, especially on wet roads and in off-road riding.
- Insufficient pressure results in abnormal wear and overheating of the tyres.
- The front and rear tyres must have the same tread design.
- Always measure the inflating pressures when the tyres are cold.
- Keep the tyre pressures within the prescribed range.

CHAIN

Checking the drive chain periodically to ensure longer chain life. Always keep it lubricated and clean of deposited dirt.

Take special care in preventing the lubricant from coming into contact with the rear tyre or brake disc, otherwise the tyre grip and the action of the brake would be greatly reduced, making it very difficult to control the vehicle.

CHECK AND ADJUST TIGHTENING CHAIN

Position the drive on a flat base ensuring stability.

If the chain play exceeds 30÷35 mm tension the chain.

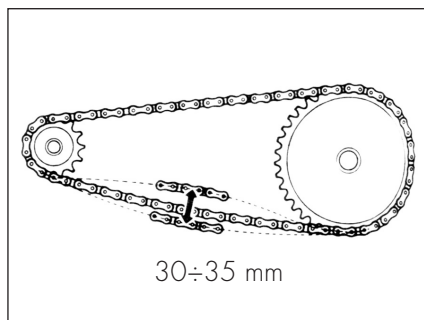

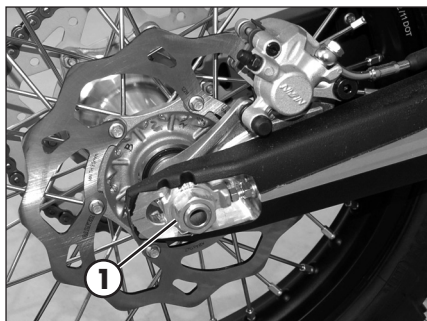

- Loosen the pin **1**.

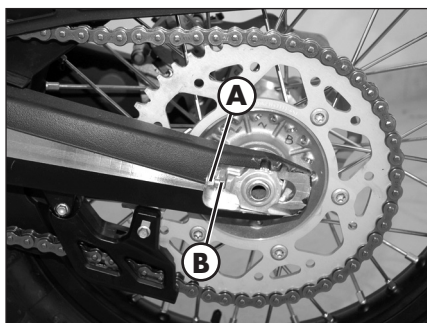

- Loosen counter nuts **A** on either side of the fork.
- Turn adjusting screws **B** on either side until the desired chain tension is obtained.
- Tighten counter nuts **A** on either side of the fork.

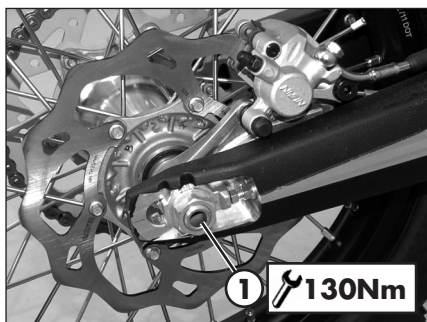

- Tighten the pin **1** to the torque indicated.

CHECK FOR CHAIN WEAR

Shift into neutral, pull up the upper stretch of the chain with a force of 10 - 15 kg (see figure). Measure the length of 18 links on the lower stretch of the chain. If the length is ≥ 272 mm, replace the chain. Chains do not always wear evenly. For this reason it is important that the measurement is taken at different points along the chain.

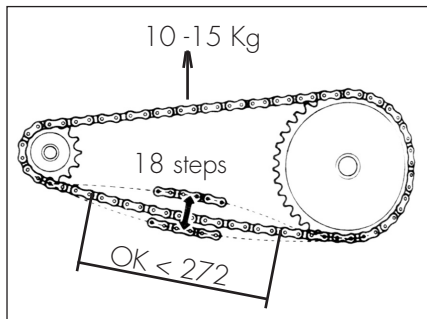

When fitting a new chain, be sure to replace the chainring and sprocket as well. New chains wear more quickly if fitted on old and worn sprockets. After replacing the chain, adjust its tension as described on page 65.

HEADLIGHT

Keep the headlight glass clean at all times (see page 71).

Periodically check the correct angle of the light beam.

REPLACING THE HEADLIGHT BULBS

Release both spring washers and move forward the lamp holder front cowl.

Carefully remove the headlight bulb **1** together with lamp holder. To replace the high beam / low beam, lift the rubber cover **2**, release connector, push on the spring **3** and remove the lamp holder and replace the light bulb with a new one. Be careful not to touch the bulb so as not to compromise its efficiency.

To refit, follow the procedure above but in reverse order.

Fasten the lamp holder front cowl to the supporting pins and fix it with the two elastics.

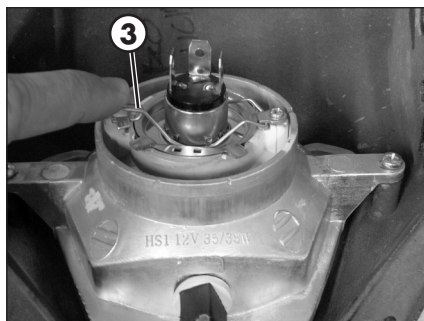
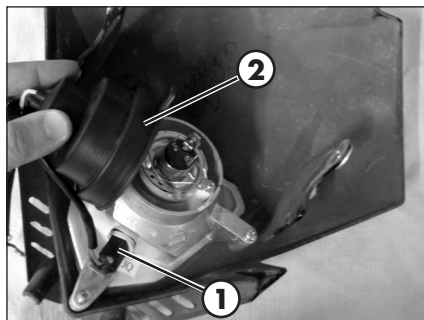

TAIL LIGHT

Keep the tail light glass clean at all times (see page 71).

The LED tail light is sealed. In the case of burnout of one or more LEDs it is necessary to replace the entire group.

To replace, contact authorised Betamotor customer service.

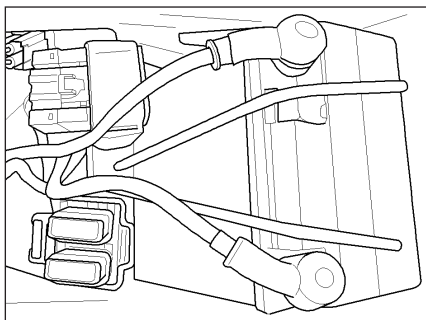

BATTERY

Battery is located under the saddle and requires no maintenance.

Keep the battery terminals clean. If necessary, protect them with a thin film of acid-free grease.



WARNING:

The battery contains hazardous substances:

- Keep the batterie out of the reach of children.



- Keep sparks and open flames away from the battery.



- Charge the battery only in well-ventilated areas, keeping it away from flammable materials. Use only chargers suitable for charging lithium-ion batteries.



- Do not attempt to charge fully exhausted batteries with a voltage lower than the minimum 9V. In this case, dispose of the battery according to applicable regulations.



- Do not remove the protections.

- When installing the battery, be sure to observe the polarity of the terminals.

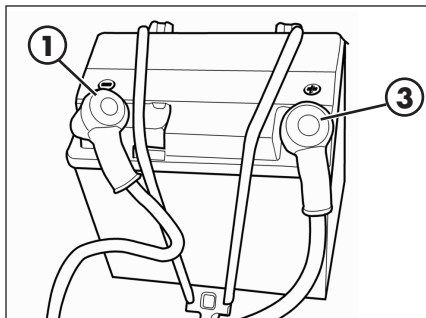

BATTERY REMOVAL

Shut off all electrical users and stop the engine.

Remove the saddle (page 80).

FIRST remove the cap **1** of the negative pole and disconnect the negative lug **2** (black) from the negative pole.

THEN remove the cap of the positive pole **3** and disconnect the positive lug **4** (red) from the positive pole (+).

Release the rubber band **5**.

Remove the battery.

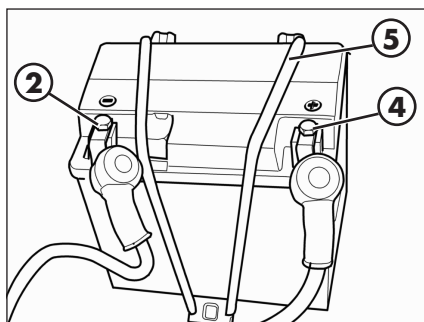

BATTERY ASSEMBLY

When fitting the battery, insert it with the terminals as shown in picture.

Reattach the rubber band **5**.

FIRST Connect the positive lug **4** (red) to the positive pole (+) of the battery by pushing the protective cap **3** in its position.

THEN secure the negative lug **2** (black) to the negative pole (-) of the battery by bringing the relative protective cap **1** in position.

Refit the saddle (page 80).

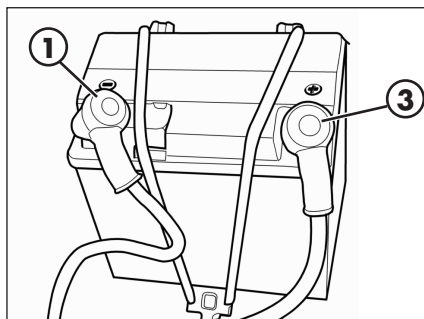
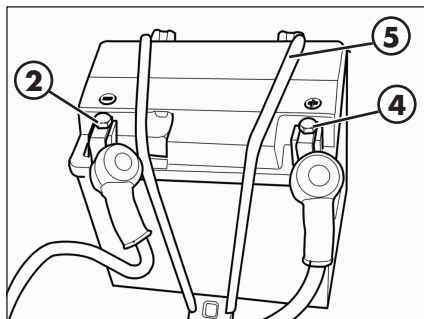

INACTIVITY

If the vehicle is not going to be used for a long time:

- remove the battery (page 68).
- charge with an adequate charger (page 70).
- store the battery in a dry place. The ideal temperature for storing the lithium-ion battery is 20°C.



CHARGING THE BATTERY

Check the battery charge using a multimeter or by pressing the "TEST" button on the battery

- Voltage < 9V or "LOW":
 - Do NOT charge the battery
 - Replace the battery with a new equivalent one
- Voltage < 12.4V or "MED":
 - Charge the battery

Guidelines to charge the battery:



Use ONLY chargers suitable for charging lithium-ion batteries.

Maximum charging voltage: 14.4V

Maximum charging current: 3.0A

Maximum charge time: 12h

Recharge the battery regularly with a specific battery charger when the vehicle is not used for more than 6 months

Ideal temperature for charging lithium ion batteries: 20 °C.

FUSES

To access the fuse, remove the saddle (page 80).

Fuse **1**: in the event of a blown fuse, the services listed in the table are not operational:

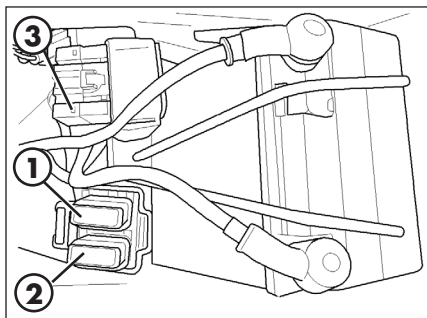

Rear lights
Stop
Front lights
Tachometer and control lights
Turn lights
Klaxon
Electric fan (optional)

Fuse **2**: in the event of a blown fuse, the vehicle stops/does not start.

Fuse **3**: in the event of a blown fuse, the vehicle does not start/stops.

Three spare fuses comes with the kit accompanying the vehicle.





A blown fuse should only be replaced with another of the same type.

Should the new fuse also burn out when fitted, immediately contact a specialized BETAMOTOR dealer.

CLEANING THE VEHICLE

GENERAL PRECAUTIONS

-  **WARNING:** Do not clean your vehicle with a high-pressure device with a strong jet of water. Excessive pressure can reach electrical components, connectors, flexible cables, bearings, etc and can damage or destroy them.
-  **WARNING:** Wash motorbikes frequently with cold water that are used near the sea (salty air) and on roads subject to salt spreading in winter. Cover with a film of oil or silicone spray unpainted parts and the most exposed parts such as wheels, forks and swingarm. Do not treat rubber parts and brakes.

When cleaning, avoid direct exposure to sunlight.

Close off the exhaust system to prevent water from entering.

-  Avoid directing the jet of water onto the air filter box cover and the throttle body.

WASHING MODE



Use water jet to soften the dirt and mud accumulated on the paintwork, then remove them with a soft bodywork sponge soaked in water and shampoo. Subsequently rinse well with water, and dry with air and cloth or suede leather.

Detergents pollute water. Always wash the vehicle in areas equipped for collection and purification of the washing liquids.

AFTER WASHING

Proceed to the emptying of the filter box using the appropriate ventilation and drying.

After cleaning, ride a short distance until the engine reaches operating temperature.

-   **WARNING:** braking effect is reduced with wet brakes. Operate the brakes cautiously to allow them to dry.

Push back the handlebar control covers, so that water can evaporate.

When the bike is completely dry and cooled down, lubricate all moving parts.

Treat all plastic and painted components with non-aggressive detergents or products that are specific for the care of the motorcycle.

To prevent malfunction of the electrical system, treat electric contacts and switches with electrical contact spray.

⊘ ATTENTION: any oxidation of electrical contacts may result in serious malfunctioning to the power supply system.

Specifically, treat the battery poles as described on page 68 and pay particular attention to what is contained here below.

ELECTRICAL CONNECTOR MAINTENANCE

Disconnect the connectors listed below, blow compressed air on the connector both on the system and on the component side, and treat electrical contacts and switches with spray for electrical contacts.

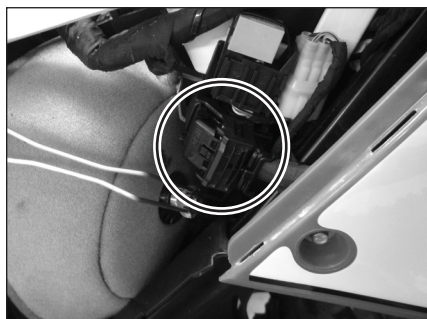

CONTROL UNIT CONNECTOR

The connector is positioned as indicated in figure.

To access it, remove the air filter cover side (page 81).



To remove the connector one must:
1) press the lock device;

- 2) rotate the safety device as shown;
- 3) remove the connector.

For re-assembly, proceed opposite the above-mentioned order.

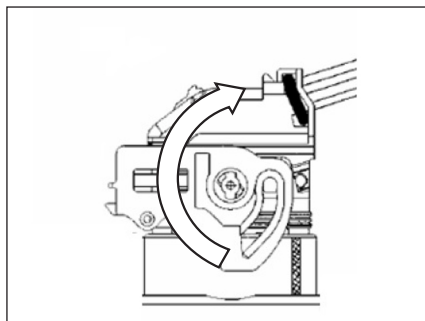

AIR PRESSURE AND TEMPERATURE SENSOR

Remove the tank (page 82).

The connector is positioned as indicated in figure.

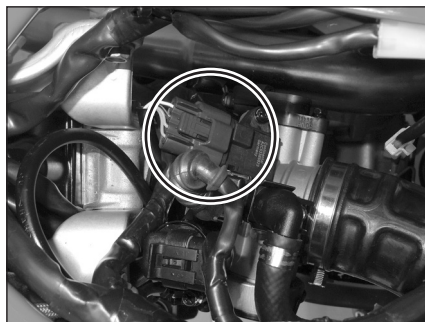

- 1) press the lock device;
- 2) Pull the connector upwards.

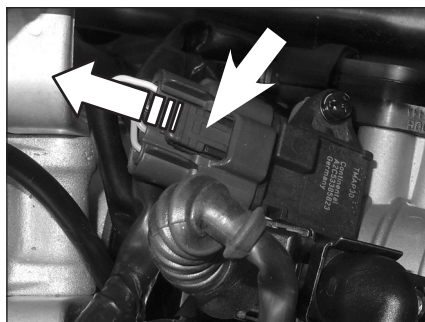

For re-assembly, proceed opposite the above-mentioned order.

Attention: at the end of the operation ensure that the connector is blocked.



4 PROLONGED INACTIVITY

A few simple operations should be performed to keep the vehicle in good condition whenever it is to remain inactive for a long period (e.g. during the winter):

- Thoroughly clean the vehicle.
- Reduce the tyre pressures by approximately 30 percent, and if possible raise the tyres off the ground.
- Cover the unpainted parts, excepting the brakes and the rubber parts, with a film of oil or spray silicone.
- Remove the battery (page 68) and follow the instructions for inactivity (page 69) and recharging (page 70).

AFTER PROLONGED INACTIVITY

- Reinstall the battery.
- Restore the tyre inflating pressures.
- Check the tightening of all the screws having an important mechanical function.

SCHEDULED MAINTENANCE VEHICLE

Engine	End of running-in - 3 hours	Coupon 1 - 30 hours	Coupon 2 - 60 hours	Coupon 3 - 90 hours	Coupon 4 - 120 hours	Coupon 5 - 150 hours	Coupon 6 - 180 hours
Engine oil	S	S	S	S	S	S	S
Paper filter oil	S	S	S	S	S	S	S
Wire netting filter oil	P	P	P	P	P	P	P
Gear and clutch oil	S	S	S	S	S	S	S
Engine clamping screws	C	C	C	C	C	C	C
Head screws	T						
Kick start and gearchange lever screws	C	C	C	C	C	C	C
Spark plug cap	P	P	P	S	P	P	S
Spark plug	C		S		S		S
Breather pipe	C	C	C	C	C	C	C
Countershaft bearings				S			S
Crankshaft bearings				S			S
Connecting rod				S			S
Piston and segments				S			S
Cylinder				C			C
Surface appearance of the cams				C			C
Valve clearance	C	C	C	C	C	C	C
Valves				C			S
Valve guide wear				C			C
Valve spring				C			S
Clutch disc wear		C	C	S	C	C	S
Clutch springs		C	C	S	C	C	S
Clutch hub - basket wear		C	C	C	C	C	C
Gearbox bearing (crankcase side)				S			S
Surface appearance of the gearbox				C			C
Water pump seals				S			S
Oil pump control gears				S			S

Key

C Check (Clean, adjust, lubricate, replace as necessary)**S Replace/renew****R Adjust****P Clean****T Tighten**

The required engine maintenance is strongly depending on the level of use and on the accordingly done periodic checks and service.

The mentioned maintenance intervals are for the normal use of the vehicle, subject to the condition that the engine was never running under extraordinary conditions and the periodic service was done accurately.

		End of running-in - 3 hours	Coupon 1 - 30 hours	Coupon 2 - 60 hours	Coupon 3 - 90 hours	Coupon 4 - 120 hours	Coupon 5 - 150 hours	Coupon 6 - 180 hours
Carburetor	Tightness	C	C	C	C	C	C	C
	Idling setting	C	C	C	C	C	C	C
	Fuel pipe	C	C	C	C	C	C	C
	Breather pipe	C	C	C	C	C	C	C
Assembling groups	Coolant system tightness and coolant level	C	C	C	C	C	C	C
	Exhaust manifold tightness	C	C	C	C	C	C	C
	Drives sliding and regulation	C	C	C	C	C	C	C
	Liquid level clutch pump	C	C	C	C	C	C	C
	Airbox and air filter	P	P	P	P	P	P	P
	Chain, plate wheel and pinion	C	C	C	C	C	C	C
Brake	Liquid level, pads thickness	C	C	C	C	C	C	C
	Disc thickness	C	C	C	C	C	C	C
	Pipe tightness	C	C	C	C	C	C	C
Cycling	Idle travel levers and drives sliding	C	C	C	C	C	C	C
	Shock absorber and telescopic fork tightness	C	C	C	C	C	C	C
	Rear suspension linkage	C	C	C	C	C	C	C
	Dust seal	P	P	P	P	P	P	P
	Bearings of steering	C	C	C	C	C	C	C
Wheels	Bolts	T	T	T	T	T	T	T
	Wheel spokes and rim coaxiality	C	C	C	C	C	C	C
	Tyres (wear and pressure)	C	C	C	C	C	C	C
	Bearings clearance	C	C	C	C	C	C	C

Key

C Check (Clean, adjust, lubricate, replace as necessary)

S Replace/renew

R Adjust

P Clean

T Tighten

WARNING:

For any service requirements, please contact Betamotor's Authorized Service Network.

TIGHTENING TORQUE OVERVIEW

Here below is an overview of the tightening torque of all pieces subject to adjustment or maintenance:

Forecarriage		
	Tightening torque [Nm]	Threadlock
Wheel pin	50	
Fork foots - wheel pin	10*	
Brake caliper - Fork	35	M
U-bolt fork tube protection	1,5	
Steering head base - fork legs	12*	
Steering head - fork legs	17*	
Stem pin on steering head	20	
Lower handlebar u-bolt - steering head	40	M
Upper handlebar u-bolt - lower handlebar u-bolt	25	

Rear axle		
	Tightening torque [Nm]	Threadlock
Wheel pin	130	
Rear shock absorber - frame	70	
Rear shock absorber - rocker arm	70	
Connecting rod - frame	90	
Connecting rod - rocker arm	90	
Rocker arm - swinging arm	90	

Engine		
	Tightening torque [Nm]	Threadlock
Engine oil drain plug	15	
Paper oil filter plug	10	
Gearbox oil drain plug	20	

M Medium strength threadlock



WARNING:

Tightening of the screws should be carried out by adjusting the torque wrench to the stability torque with repeated tightening until stability torque has been achieved.

Fairings		
	Tightening torque [Nm]	Notes
Fuel tank to the frame (front fixing)	10	
Fuel tank to the frame (rear fixing)	10	Grease
Fuel tank fairings to the radiator	7	

CHAPTER 5 REMOVING AND INSTALLING SUPERSTRUCTURES

CONTENTS

Removing and installing of the saddle.....	80
Removing and installing air filter cover panel.....	81
Removing and installing of the tank	82

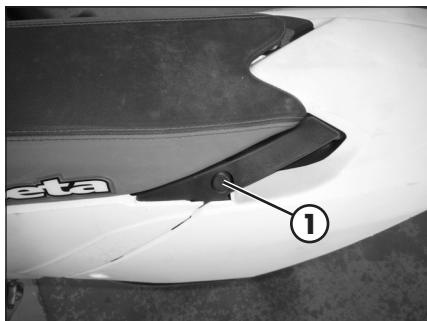

REMOVING AND INSTALLING OF THE SADDLE

Press button **1**.

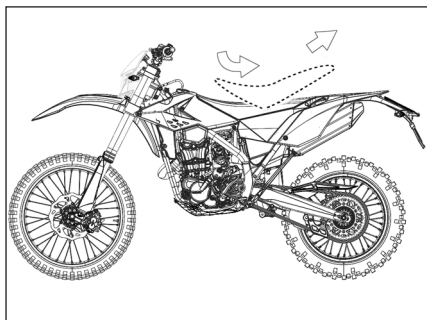

Remove the saddle towards the rear of the motorcycle.



To re-assemble:

Insert the cavity **1** of the saddle in slot **2**.

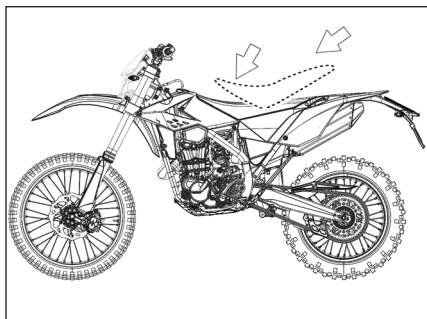

Press the saddle down in the middle and at the same time, push it forwards until the bayonet joint engages in its seat.



WARNING

Make sure the bayonet joint **3** is firmly inserted into the button lock.

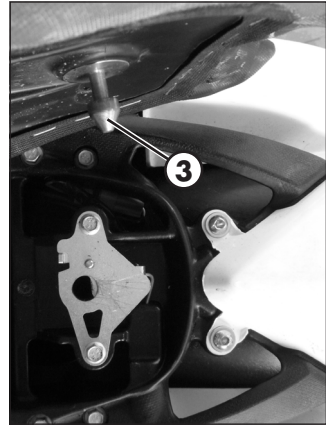

REMOVING AND INSTALLING AIR FILTER COVER PANEL

Remove the saddle (page 80).

Grab the side panel in the front side and pull out.

To refit insert the tabs **1** into their slots.

Slide the side panel toward the vehicle.

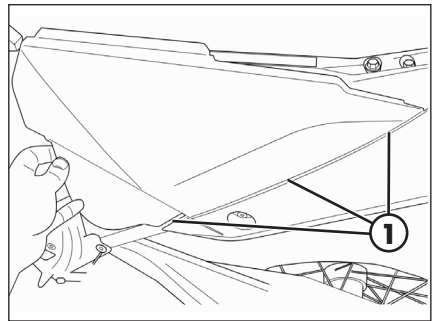



REMOVING AND INSTALLING OF THE TANK

Remove the saddle (page 80).

Remove the two screws fastening the tank to the frame and the screw (one per side) securing the fairing to the radiator.

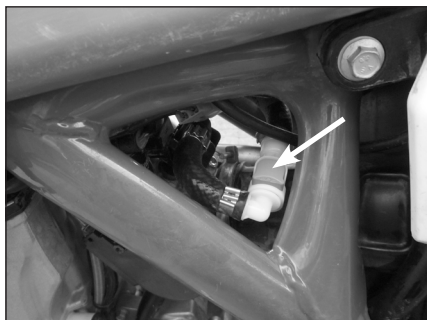

Disconnect the fuel hose by pressing the appropriate button of the quick coupling.

Lift the tank.

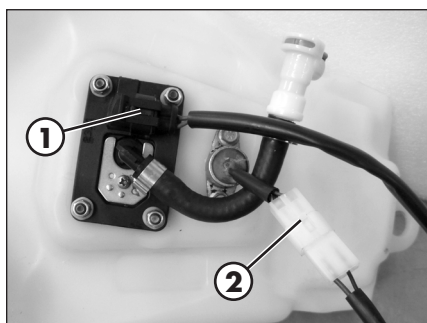

Disconnect the electrical connector **1** and **2**.

Remove the tank with its fairings.

Reassemble proceeding in the reverse order.

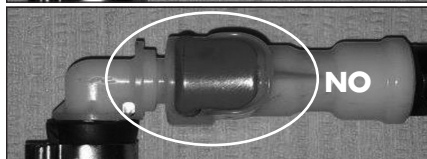
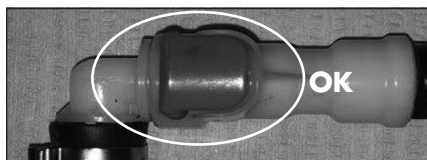

! **WARNING**
For safety reason, the fuel flow is stopped when the connector is even partially engaged.
Make sure that the fuel quick release fittings are well inserted.

CHAPTER 6 TROUBLESHOOTING

CONTENTS

Troubleshooting	84
Alphabetical index	85

6 TROUBLESHOOTING

TRUBLESHOOTING

PROBLEM	CAUSE	REMEDY
The engine starts but the telltale "MIL" lights on 	Engine management system fault	Contact authorised BETAMOTOR customer service
The electric starter does not turn	Decompressor failure	Contact authorised BETAMOTOR customer service
	Flat battery	Check the battery
	Blown fuse	Replace
	Defective relay	Contact authorised BETAMOTOR customer service
	Defective starter motor	Contact authorised BETAMOTOR customer service
The engine rotates, but does not start	Fuel quick release fittings incorrectly inserted	Check that the fuel quick release fittings are properly inserted (page 82).
	Spark plug dirty	Clean or replace the spark plug
	Spark gap wrongly adjusted	Restore the spark gap
	Faulty ignition/injection system	Contact authorised BETAMOTOR customer service
"High Voltage" appears on the instrument	- Overcharging	Disconnect the battery (page 68) Contact authorised BETAMOTOR customer service
The motor stops or splutters	Lack of fuel	Refuel
Engine overheats	Radiator grill blocked	Remove and clean the grill
	Radiator (air side) blocked	Clean the radiator
	Insufficient air flow	Check that the cooling fan is working correctly
	Silencer partly clogged	Contact authorised BETAMOTOR customer service
Front braking poor	Brake pads worn	Contact authorised BETAMOTOR customer service
	Air or humidity in the hydraulic circuit	Contact authorised BETAMOTOR customer service
Rear braking poor	Brake pads worn	Contact authorised BETAMOTOR customer service
	Air or humidity in the hydraulic circuit	Contact authorised BETAMOTOR customer service

ALPHABETICAL INDEX

Adjusting fork	39
Adjustment of gas clearance.....	37
Air filter	49
Battery.....	68
Brakes	36
Chain	65
Check and adjusting of steering play.....	60
Checks before and after use	30
Cleaning the vehicle.....	71
Clutch.....	36
Clutch control	58
Digital rpm indicator operating instructions.....	20
Electrical connector maintenance	72
Engine oil.....	44
Engine shut-down	32
Familiarizing with the vehicle.....	9
Front brake.....	52
Fuelling.....	31
Fuses	70
Gearbox oil	46
Handlebar adjustment	37
Headlight.....	67
Idle adjustment	37
Key to symbols.....	36
Liquid coolant	47
Main parts	16

Oil fork	61
Operating instructions.....	5
Prolonged inactivity	74
Rear brake	55
Rear suspension leverage.....	64
Recommended lubricants and liquid	13
Removing and installing air filter cover panel.....	81
Removing and installing of the saddle.....	80
Removing and installing of the tank	82
Replacing the headlight bulbs.....	67
Riding safety	6
Running in.....	30
Scheduled maintenance vehicle	75
Shock absorber.....	39
Spark plug	51
Specifications	10
Starting the engine	32
Symbols.....	5
Tail light.....	67
Tightening torque overview	77
Tools kit	8
Troubleshooting	84
Tyres.....	65
Vehicle identification data	8
Vehicle preparation for use in heavy-duty conditions.....	33