



OWNER'S MANUAL

TTR250

TTR250V(C)

LIT-11626-19-30

5GF-28199-17

⚠ WARNING

The engine exhaust from this product contains chemicals known to the State of California to cause cancer, birth defects or other reproductive harm.

YAMAHA

LIT-CALIF-65-01

Emission Control Information- Yamaha Motor Co., Ltd. YAMAHA

This 2006 model year Snowmobile, ATV or Off highway Motorcycle is not subject to the phased-in emission standards and related requirements for model year 2006 applicable under 40 CFR 1051.

INTRODUCTION

EAU10060



Congratulations on your purchase of the Yamaha TTR250V. This model is the result of Yamaha's vast experience in the production of fine sporting, touring, and pacesetting racing machines. It represents the high degree of craftsmanship and reliability that have made Yamaha a leader in these fields.

This manual will give you an understanding of the operation, inspection, and basic maintenance of this machine. If you have any questions concerning the operation or maintenance of your machine, please consult a Yamaha dealer.

IMPORTANT MANUAL INFORMATION

EAU10160

Particularly important information is distinguished in this manual by the following notations:

	The Safety Alert Symbol means ATTENTION! BECOME ALERT! YOUR SAFETY IS INVOLVED!
 WARNING	Failure to follow WARNING instructions could result in severe injury or death to the machine operator, a bystander or a person inspecting or repairing the machine.
CAUTION:	A CAUTION indicates special precautions that must be taken to avoid damage to the machine.
NOTE:	A NOTE provides key information to make procedures easier or clearer.

NOTE:

- This manual should be considered a permanent part of this machine and should remain with it even if the machine is subsequently sold.
- Yamaha continually seeks advancements in product design and quality. Therefore, while this manual contains the most current product information available at the time of printing, there may be minor discrepancies between your machine and this manual. If you have any questions concerning this manual, please consult your Yamaha dealer.

EWA10010

WARNING

PLEASE READ THIS MANUAL AND THE “YOU AND YOUR MOTORCYCLE: RIDING TIPS” BOOKLET CAREFULLY AND COMPLETELY BEFORE OPERATING THIS MACHINE. DO NOT ATTEMPT TO OPERATE THIS MACHINE UNTIL YOU HAVE ATTAINED ADEQUATE KNOWLEDGE OF ITS CONTROLS AND OPERATING FEATURES AND UNTIL YOU HAVE BEEN TRAINED IN SAFE AND PROPER RIDING TECHNIQUES. REGULAR INSPECTIONS AND CAREFUL MAINTENANCE, ALONG WITH GOOD RIDING SKILLS, WILL ENSURE THAT YOU SAFELY ENJOY THE CAPABILITIES AND THE RELIABILITY OF THIS MACHINE.

IMPORTANT MANUAL INFORMATION

EWA10040

 **WARNING**

THIS MACHINE IS DESIGNED AND MANUFACTURED FOR OFF-ROAD USE ONLY. IT IS ILLEGAL TO OPERATE THIS MACHINE ON ANY PUBLIC STREET, ROAD OR HIGHWAY. SUCH USE IS PROHIBITED BY LAW. THIS MACHINE COMPLIES WITH ALMOST ALL STATE OFF-HIGHWAY NOISE LEVEL AND SPARK ARRESTER LAWS AND REGULATIONS. PLEASE CHECK YOUR LOCAL RIDING LAWS AND REGULATIONS BEFORE OPERATING THIS MACHINE.

IMPORTANT MANUAL INFORMATION

EAU10192



**TTR250V
OWNER'S MANUAL
©2005 by Yamaha Motor Corporation, U.S.A.
1st edition, April 2005
All rights reserved.
Any reprinting or unauthorized use
without the written permission of
Yamaha Motor Corporation, U.S.A.
is expressly prohibited.
Printed in Japan.
P/N LIT-11626-19-30**

TABLE OF CONTENTS

SAFETY INFORMATION	1-1	OPERATION AND IMPORTANT	
Location of important labels	1-5	RIDING POINTS	5-1
DESCRIPTION	2-1	Starting and warming up a cold	
Left view	2-1	engine	5-1
Right view	2-2	Starting a warm engine	5-2
Controls and instruments.....	2-3	Shifting	5-2
INSTRUMENT AND CONTROL		Engine break-in	5-3
FUNCTIONS	3-1	Parking	5-3
Main switch	3-1	PERIODIC MAINTENANCE AND	
Tripmeter	3-1	MINOR REPAIR	6-1
Handlebar switches	3-1	Owner's tool kit	6-1
Clutch lever	3-2	Periodic maintenance chart for the	
Shift pedal	3-2	emission control system	6-2
Brake lever	3-3	General maintenance and lubrication	
Brake pedal	3-3	chart	6-3
Fuel tank cap	3-3	Removing and installing the cowling	
Fuel	3-4	and panels	6-6
Fuel tank breather hose	3-5	Checking the spark plug	6-7
Fuel cock	3-5	Engine oil and oil filter element	6-8
Starter (choke) knob "1\2"	3-6	Cleaning the air filter element	6-12
Seat	3-6	Cleaning the spark arrester	6-13
Adjusting the front fork	3-7	Carburetor	6-14
Adjusting the shock absorber		Checking the throttle cable free	
assembly	3-9	play	6-14
Starting circuit cut-off system	3-11	Valve clearance	6-15
PRE-OPERATION CHECKS	4-1	Tires	6-15
Pre-operation check list	4-2	Spoke wheels	6-17
		Accessories and replacement	
		parts	6-17
		Adjusting the clutch lever free	
		play	6-18
		Adjusting the brake lever free	
		play	6-19
		Checking the front and rear brake	
		pads	6-19
		Checking the brake fluid level	6-20
		Changing the brake fluid	6-21
		Drive chain slack	6-21
		Cleaning and lubricating the drive	
		chain	6-23
		Checking and lubricating the	
		cables	6-23
		Checking and lubricating the throttle	
		grip and cable	6-24
		Checking and lubricating the brake	
		and clutch levers	6-24
		Lubricating the brake pedal	6-24
		Checking and lubricating the	
		sidestand	6-25
		Checking the front fork	6-25
		Checking the steering	6-26
		Checking the wheel bearings	6-26
		Battery	6-27
		Replacing the fuse	6-28
		Replacing the headlight bulb	6-29
		Replacing the taillight bulb	6-30
		Supporting the machine	6-31
		Front wheel	6-31
		Rear wheel	6-33
		Troubleshooting	6-34

TABLE OF CONTENTS

Troubleshooting chart6-35

MACHINE CARE AND

STORAGE7-1

Care7-1

Storage7-3

SPECIFICATIONS8-1

CONSUMER INFORMATION.....9-1

Identification numbers9-1

Motorcycle noise regulation9-3

Maintenance record9-4

YAMAHA MOTOR CORPORATION,

U.S.A. OFF-ROAD MOTORCYCLE

LIMITED WARRANTY9-5

YAMAHA EXTENDED SERVICE

(Y.E.S.)9-7

EAU10332

THIS MACHINE IS A SINGLE TRACK VEHICLE. ITS SAFE USE AND OPERATION IS DEPENDENT UPON THE USE OF PROPER RIDING TECHNIQUES AS WELL AS THE EXPERTISE OF THE OPERATOR. EVERY OPERATOR SHOULD KNOW THE FOLLOWING REQUIREMENTS BEFORE RIDING THIS MACHINE.

HE OR SHE SHOULD:

- OBTAIN THOROUGH INSTRUCTIONS FROM A COMPETENT SOURCE ON ALL ASPECTS OF MACHINE OPERATION.
- OBSERVE THE WARNINGS AND MAINTENANCE REQUIREMENTS IN THE OWNER'S MANUAL.
- OBTAIN QUALIFIED TRAINING IN SAFE AND PROPER RIDING TECHNIQUES.
- OBTAIN PROFESSIONAL TECHNICAL SERVICE AS INDICATED BY THE OWNER'S MANUAL AND/OR WHEN MADE NECESSARY BY MECHANICAL CONDITIONS.

Safe riding

- Always make pre-operation checks. Careful checks may help prevent an accident.
- This machine is designed for off-road use only, therefore, it is illegal to operate it on public streets, roads, or highways. Off-road use on public lands may be illegal. Please check local regulations before riding.
- This machine is designed to carry the operator only. No passengers.
- Many accidents involve inexperienced operators.
 - Make sure that you are qualified and that you only lend your machine to other qualified operators.
 - Know your skills and limits. Staying within your limits may help you to avoid an accident.
- Many accidents have been caused by error of the machine operator. A typical error made by the operator is veering wide on a turn due to EXCESSIVE SPEED or undercornering (insufficient lean angle for

the speed). Never travel faster than warranted by conditions.

- Ride cautiously in unfamiliar areas. You may encounter hidden obstacles that could cause an accident.
- The posture of the operator is important for proper control. The operator should keep both hands on the handlebar and both feet on the operator footrests during operation to maintain control of the machine.
- Never ride under the influence of alcohol or other drugs.

Protective apparel

The majority of fatalities from machine accidents are the result of head injuries. The use of a safety helmet is the single most critical factor in the prevention or reduction of head injuries.

- Always wear an approved helmet.
- Wear a face shield or goggles. Wind in your unprotected eyes could contribute to an impairment of vision that could delay seeing a hazard.
- The use of a jacket, heavy boots,

SAFETY INFORMATION

1

trousers, gloves, etc., is effective in preventing or reducing abrasions or lacerations.

- Never wear loose-fitting clothes, otherwise they could catch on the control levers, footrests, or wheels and cause injury or an accident.
- Never touch the engine or exhaust system during or after operation. They become very hot and can cause burns. Always wear protective clothing that covers your legs, ankles, and feet.

Modifications

Modifications made to this machine not approved by Yamaha, or the removal of original equipment, may render the machine unsafe for use and may cause severe personal injury. Modifications may also make your machine illegal to use.

Loading and accessories

Adding accessories or cargo to your machine can adversely affect stability and handling if the weight distribution of the machine is changed. To avoid the

possibility of an accident, use extreme caution when adding cargo or accessories to your machine. Use extra care when riding a machine that has added cargo or accessories. Here are some general guidelines to follow if loading cargo or adding accessories to your machine:

Loading

The total weight of the operator, accessories and cargo must not exceed the maximum load limit of 90 kg (198 lb). When loading within this weight limit, keep the following in mind:

- Cargo and accessory weight should be kept as low and close to the machine as possible. Make sure to distribute the weight as evenly as possible on both sides of the machine to minimize imbalance or instability.
- Shifting weights can create a sudden imbalance. Make sure that accessories and cargo are securely attached to the machine before riding. Check accessory mounts and cargo restraints frequently.

- Never attach any large or heavy items to the handlebar, front fork, or front fender. These items, including such cargo as sleeping bags, duffel bags, or tents, can create unstable handling or a slow steering response.

Accessories

Genuine Yamaha accessories have been specifically designed for use on this machine. Since Yamaha cannot test all other accessories that may be available, you must personally be responsible for the proper selection, installation and use of non-Yamaha accessories. Use extreme caution when selecting and installing any accessories.

Keep these guidelines in mind for mounting accessories in addition to those provided under "Loading".

- Never install accessories or carry cargo that would impair the performance of your machine. Carefully inspect the accessory before using it to make sure that it does not in any way reduce ground clearance

or cornering clearance, limit suspension travel, steering travel or control operation, or obscure lights or reflectors.

- Accessories fitted to the handlebar or the front fork area can create instability due to improper weight distribution or aerodynamic changes. If accessories are added to the handlebar or front fork area, they must be as lightweight as possible and should be kept to a minimum.
- Bulky or large accessories may seriously affect the stability of the machine due to aerodynamic effects. Wind may attempt to lift the machine, or the machine may become unstable in cross winds.
- Certain accessories can displace the operator from his or her normal riding position. This improper position limits the freedom of movement of the operator and may limit control ability, therefore, such accessories are not recommended.

- Use caution when adding electrical accessories. If electrical accessories exceed the capacity of the machine's electrical system, an electric failure could result, which could cause a dangerous loss of lights or engine power.

Gasoline and exhaust gas

- **GASOLINE IS HIGHLY FLAMMABLE:**
 - Always turn the engine off when refueling.
 - Take care not to spill any gasoline on the engine or exhaust pipe(s)/muffler(s) when refueling.
 - Never refuel while smoking or in the vicinity of an open flame.
- Never start the engine or let it run for any length of time in a closed area. The exhaust fumes are poisonous and may cause loss of consciousness and death within a short time. Always operate your machine in an area that has adequate ventilation.
- Always turn the engine off before

leaving the machine unattended and remove the key from the main switch. When parking the machine, note the following:

- The engine and exhaust pipe(s)/muffler(s) may be hot, therefore, park the machine in a place where pedestrians or children are not likely to touch these hot areas.
- Do not park the machine on a slope or soft ground, otherwise it may fall over.
- Do not park the machine near a flammable source (e.g., a kerosene heater, or near an open flame), otherwise it could catch fire.
- When transporting the machine in another vehicle, make sure that it is kept upright and that the fuel cock(s) are turned to "ON" or "RES" (for vacuum type)/"OFF" (for manual type). If the machine should lean over, gasoline may leak out of the carburetor or fuel tank.
- If you should swallow any gaso-

SAFETY INFORMATION

line, inhale a lot of gasoline vapor, or allow gasoline to get into your eyes, see your doctor immediately. If any gasoline spills on your skin or clothing, immediately wash the affected area with soap and water and change your clothes.

1

SAFETY INFORMATION

EAU10381

Location of important labels

Please read the following important labels carefully before operating this vehicle.

1

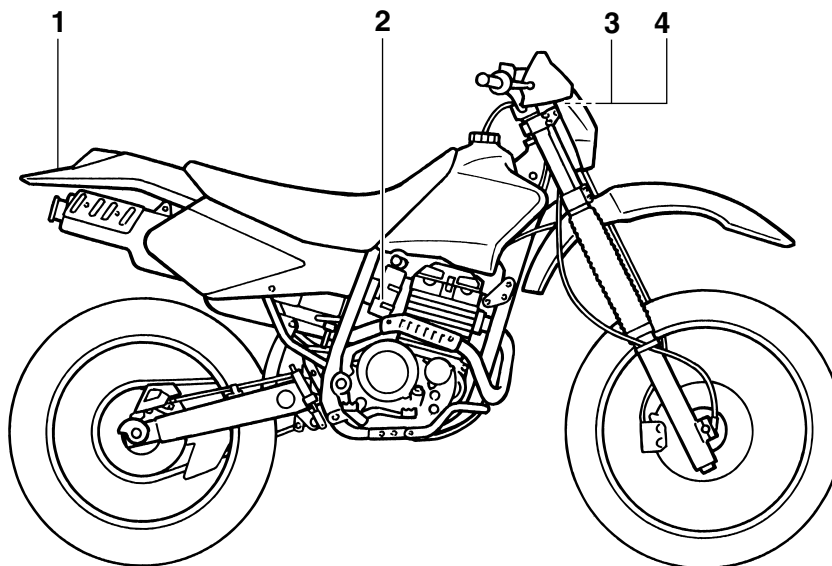

1

 WARNING

Riding as a passenger can cause the vehicle to go out of control.
Loss of control can cause a collision or rollover, which can result in severe injury or death.

NEVER ride as a passenger.

3XJ-2151H-A1

3

 WARNING

- **BEFORE YOU OPERATE THIS VEHICLE, READ THE OWNER'S MANUAL AND ALL LABELS.**
- **NEVER CARRY A PASSENGER.** You increase your risk of losing control if you carry a passenger.
- **NEVER OPERATE THIS VEHICLE ON PUBLIC ROADS.** You can collide with another vehicle if you operate this vehicle on a public road.
- **ALWAYS WEAR AN APPROVED MOTORCYCLE HELMET,** eye protection, and protective clothing.
- **EXPERIENCED RIDER ONLY.**

5PA-2118K-00

2

 WARNING

This unit contains high pressure nitrogen gas. Mishandling can cause explosion.

- Read owner's manual for instructions.
- Do not incinerate, puncture or open.

YAMAHA 4AA-22259-80

4

TIRE INFORMATION

Cold tire normal pressure should be set as follows.

FRONT : 100 kPa,{1.00 kgf/cm²}, 15 psi
REAR : 100 kPa,{1.00 kgf/cm²}, 15 psi

3RV-21668-A0

1

DESCRIPTION

EAU10410

Left view

2

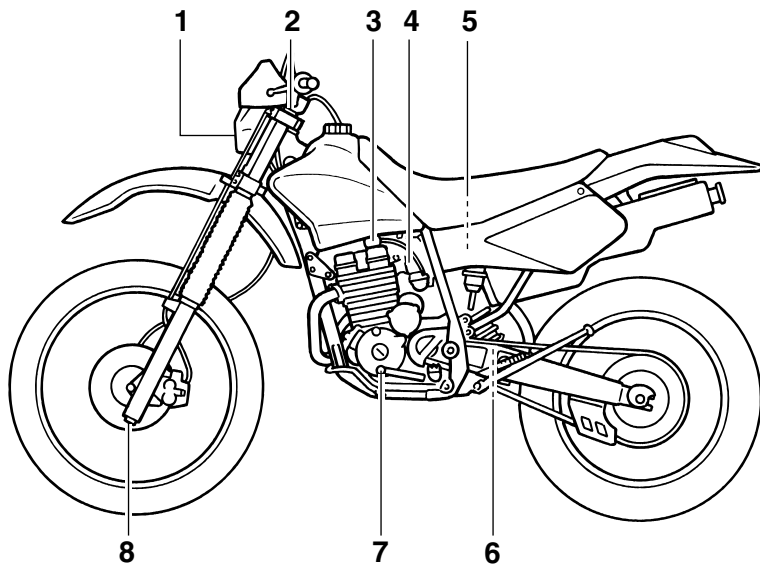

1. Headlight (page 6-29)

2. Front fork air valve (page 3-7)

3. Fuel cock (page 3-5)

4. Starter (choke) knob (page 3-6)

5. Air filter element (page 6-12)

6. Shock absorber assembly rebound damping force adjusting dial
(page 3-9)

7. Shift pedal (page 3-2)

8. Front fork damping adjusting screw (page 3-7)

Right view

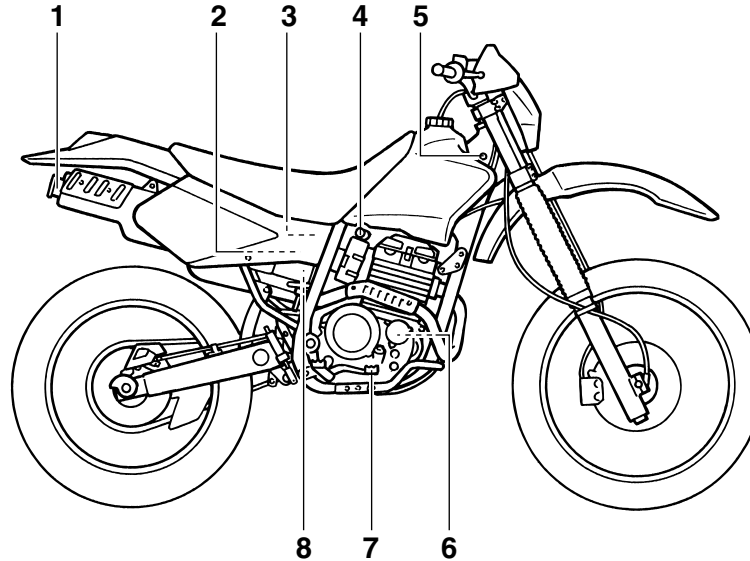

1. Spark arrester (page 6-13)
2. Battery (page 6-27)
3. Fuse (page 6-28)
4. Shock absorber assembly compression damping force adjusting knob (page 3-9)
5. Main switch (page 3-1)
6. Engine oil filter element (page 6-8)
7. Brake pedal (page 3-3)

8. Shock absorber assembly spring preload adjusting nut (page 3-9)

DESCRIPTION

EAU10430

Controls and instruments

2

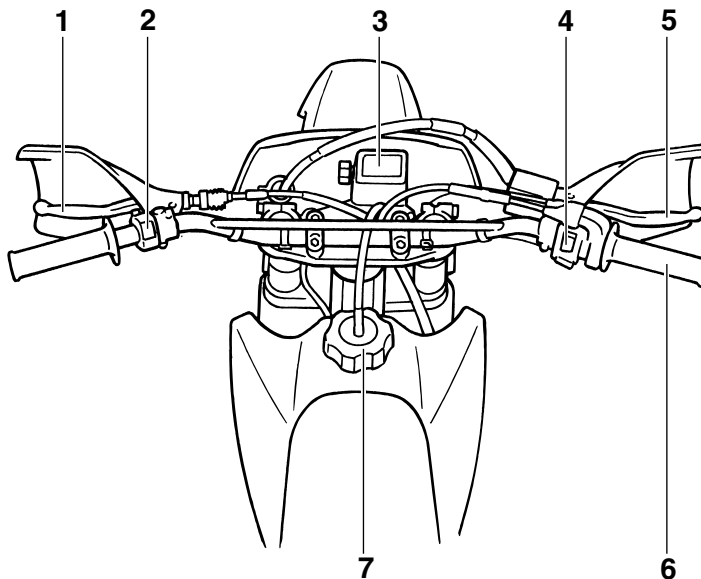

1. Clutch lever (page 3-2)
2. Left handlebar switch (page 3-1)
3. Tripmeter (page 3-1)
4. Right handlebar switches (page 3-1)
5. Brake lever (page 3-3)
6. Throttle grip (page 6-14)
7. Fuel tank cap (page 3-3)

INSTRUMENT AND CONTROL FUNCTIONS

Main switch

EAU10450

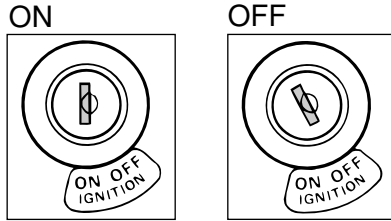

The main switch controls the ignition and lighting systems. The various main switch positions are described below.

ON

EAU10630

All electrical systems are supplied with power, and the engine can be started. The key cannot be removed.

OFF

EAU10660

All electrical systems are off. The key can be removed.

Tripmeter

EAU11830

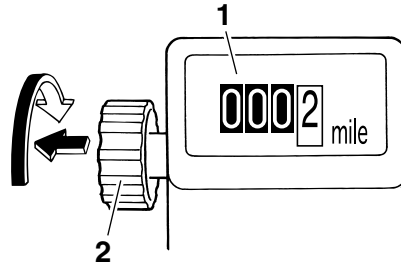

1. Tripmeter
2. Tripmeter reset knob

The tripmeter shows the distance traveled since it was last set to zero with the reset knob. The tripmeter can be used to estimate the distance that can be traveled with a full tank of fuel. This information will enable you to plan future fuel stops.

Handlebar switches

EAU12343

Left

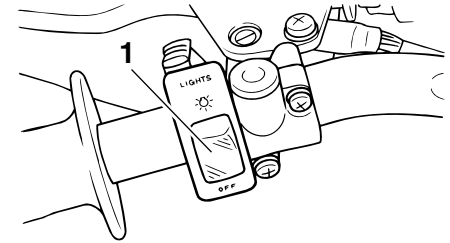

1. Light switch "☀"

Right

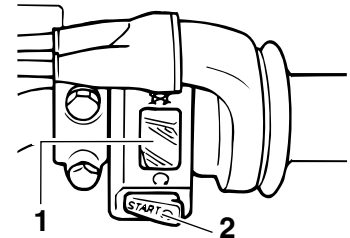

1. Engine stop switch "⊘/⊘"
2. Start switch "START"

INSTRUMENT AND CONTROL FUNCTIONS

Light switch “☀”

EAU12540

Set this switch to “☀” to turn on the headlight and the taillight.

ECA10980

CAUTION:

Always turn the key to “OFF” and light switch to “OFF” when the engine is not running, otherwise the headlight will stay on and the battery may discharge due to extended use.

3

Engine stop switch “○/⊗”

EAU12660

Set this switch to “○” before starting the engine. Set this switch to “⊗” to stop the engine in case of an emergency, such as when the vehicle overturns or when the throttle cable is stuck.

EAU12690

Start switch “START”

Push this switch to crank the engine with the starter.

ECA10050

CAUTION:

See page 5-1 for starting instructions prior to starting the engine.

Clutch lever

EAU31640

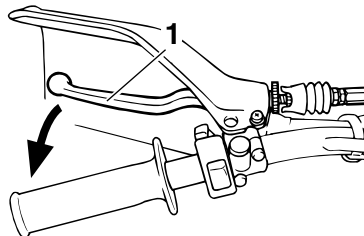

1. Clutch lever

The clutch lever is located at the left handlebar grip. To disengage the clutch, pull the lever toward the handlebar grip. To engage the clutch, release the lever. The lever should be pulled rapidly and released slowly for smooth clutch operation.

The clutch lever is equipped with a clutch switch, which is part of the starting circuit cut-off system. (See page 3-11.)

Shift pedal

EAU12870

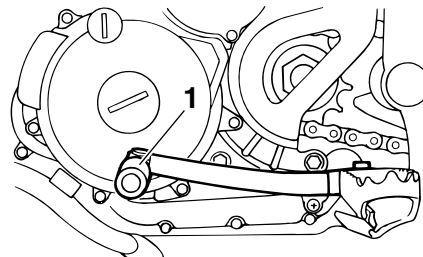

1. Shift pedal

The shift pedal is located on the left side of the engine and is used in combination with the clutch lever when shifting the gears of the 6-speed constant-mesh transmission equipped on this machine.

INSTRUMENT AND CONTROL FUNCTIONS

Brake lever

EAU12890

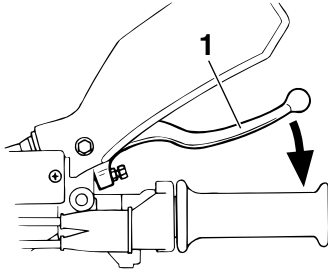

1. Brake lever

The brake lever is located at the right handlebar grip. To apply the front brake, pull the lever toward the handlebar grip.

Brake pedal

EAU12941

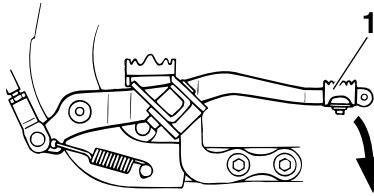

1. Brake pedal

The brake pedal is on the right side of the machine. To apply the rear brake, press down on the brake pedal.

Fuel tank cap

EAU13180

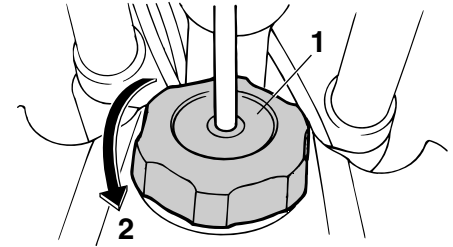

1. Fuel tank cap
2. Remove.

To remove the fuel tank cap, turn it counterclockwise, and then pull it off. To install the fuel tank cap, insert it into the tank opening, and then turn it clockwise.

EWA11090



WARNING
Make sure that the fuel tank cap is properly closed before riding.

INSTRUMENT AND CONTROL FUNCTIONS

Fuel

EAU13210

fuel may deteriorate painted surfaces or plastic parts.

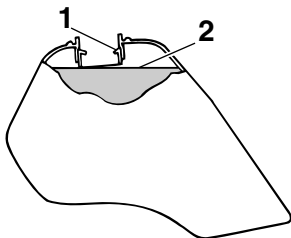

EAU13300

Recommended fuel:
UNLEADED GASOLINE ONLY
Fuel tank capacity:
9.5 L (2.51 US gal) (2.09 Imp.gal)
Fuel reserve amount:
2.0 L (0.53 US gal) (0.44 Imp.gal)

ECA11400

CAUTION:

Use only unleaded gasoline. The use of leaded gasoline will cause severe damage to internal engine parts, such as the valves and piston rings, as well as to the exhaust system.

Your Yamaha engine has been designed to use regular unleaded gasoline with a pump octane number [(R+M)/2] of 86 or higher, or a research octane number of 91 or higher. If knocking (or pinging) occurs, use a gasoline of a different brand or premium unleaded fuel. Use of unleaded fuel will extend spark plug life and reduce

maintenance costs.

Gasohol

There are two types of gasohol: gasohol containing ethanol and that containing methanol. Gasohol containing ethanol can be used if the ethanol content does not exceed 10%. Gasohol containing methanol is not recommended by Yamaha because it can cause damage to the fuel system or vehicle performance problems.

3

1. Fuel tank filler tube
2. Fuel level

Make sure that there is sufficient fuel in the tank. Fill the fuel tank to the bottom of the filler tube as shown.

EWA10880

WARNING

- Do not overfill the fuel tank, otherwise it may overflow when the fuel warms up and expands.
- Avoid spilling fuel on the hot engine.

ECA10070

CAUTION:

Immediately wipe off spilled fuel with a clean, dry, soft cloth, since

INSTRUMENT AND CONTROL FUNCTIONS

Fuel tank breather hose

EAU13410

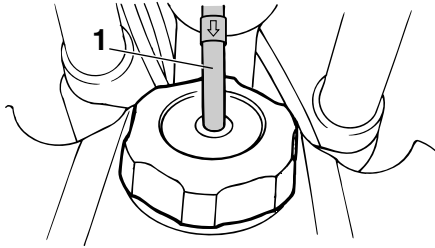

1. Fuel tank breather hose

Before operating the machine:

- Check the fuel tank breather hose connection.
- Check the fuel tank breather hose for cracks or damage, and replace it if damaged.
- Make sure that the end of the fuel tank breather hose is not blocked, and clean it if necessary.

Fuel cock

EAU13560

The fuel cock supplies fuel from the tank to the carburetor while filtering it also.

The fuel cock has three positions:

OFF

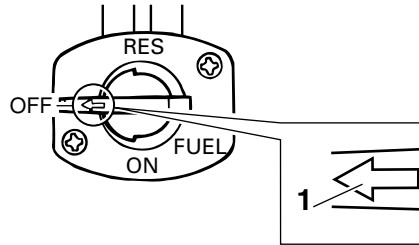

1. Arrow mark positioned over "OFF"

With the lever in this position, fuel will not flow. Always return the lever to this position when the engine is not running.

ON

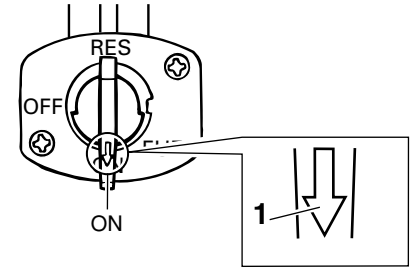

1. Arrow mark positioned over "ON"

With the lever in this position, fuel flows to the carburetor. Normal riding is done with the lever in this position.

RES

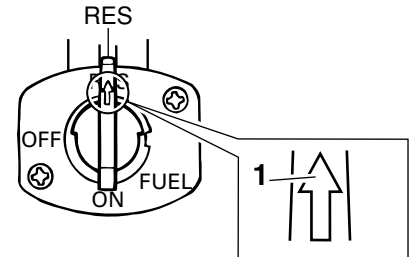

1. Arrow mark positioned over "RES"

This indicates reserve. If you run out of

INSTRUMENT AND CONTROL FUNCTIONS

fuel while riding, move the lever to this position. Fill the tank at the first opportunity. Be sure to set the lever back to “ON” after refueling!

3

EAU13600

Starter (choke) knob “”

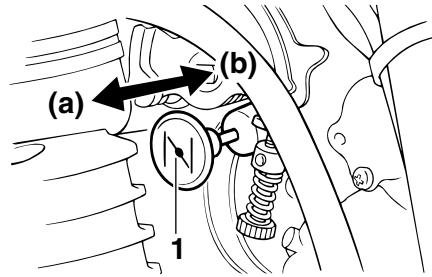

1. Starter (choke) knob “”

Starting a cold engine requires a richer air-fuel mixture, which is supplied by the starter (choke).

Move the knob in direction (a) to turn on the starter (choke).

Move the knob in direction (b) to turn off the starter (choke).

EAU13960

Seat

To remove the seat

Remove the bolts, and then pull the seat off.

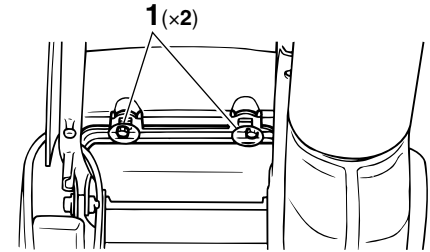

1. Bolt

To install the seat

1. Insert the projections on the front of the seat into the seat holders as shown.

EAU14671

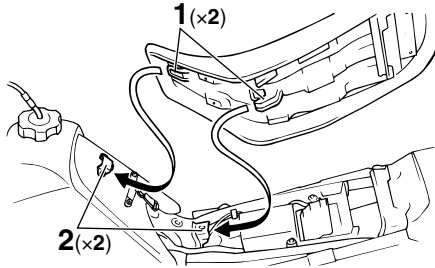

1. Projection
2. Seat holder

2. Place the seat in the original position, and then tighten the bolts.

NOTE: _____
Make sure that the seat is properly secured before riding.

Adjusting the front fork

The front fork is equipped with air valves for adjusting the spring rate and screws for adjusting the damping force.

EWA10190



WARNING
There should be no difference in air pressure between the fork legs.

Spring rate

The total spring rate is adjusted by changing the air pressure as follows.

1. Lift the front wheel off the ground according to the procedure on page 6-31.

NOTE: _____
When checking and adjusting the air pressure, there should be no weight on the front end of the vehicle.

2. Remove the air valve cap from each fork leg.

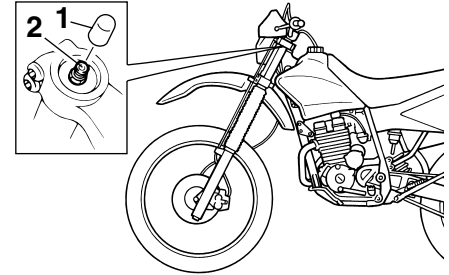

1. Front fork air valve cap
2. Front fork air valve

3. Check the air pressure in each fork leg with an air pressure gauge.

NOTE: _____
An optional air pressure gauge is available at a Yamaha dealer.

4. To increase the spring rate and thereby harden the suspension, increase the air pressure with an air pump. To decrease the spring rate and thereby soften the suspension, decrease the air pressure by pushing each valve stem down.

INSTRUMENT AND CONTROL FUNCTIONS

3

Spring rate:

Minimum (soft):

Air pressure = 0 kPa (0 psi)
(0 kgf/cm²)

Standard:

Air pressure = 0 kPa (0 psi)
(0 kgf/cm²)

Maximum (hard):

Air pressure = 40 kPa (5.8 psi)
(0.4 kgf/cm²)

ECA10090

CAUTION:

Never exceed the maximum air pressure, otherwise the front fork oil seals may become damaged.

EWA10180

WARNING

Always adjust both fork legs equally, otherwise poor handling and loss of stability may result.

5. Securely install the air valve caps.

Damping force

1. Remove the rubber cap from each fork leg.

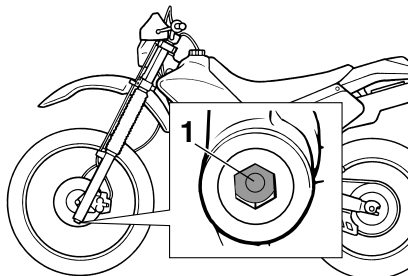

1. Rubber cap

2. To increase the damping force and thereby harden the damping, turn the adjusting screw on each fork leg in direction (a). To decrease the damping force and thereby soften the damping, turn the adjusting screw on each fork leg in direction (b).

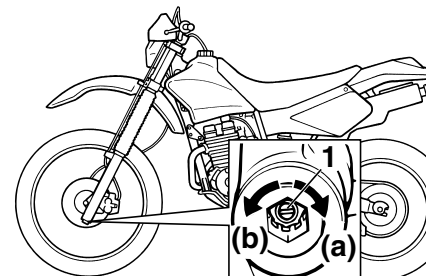

1. Damping force adjusting screw

Damping setting:

Minimum (soft):

20 clicks in direction (b)*

Standard:

11 clicks in direction (b)*

Maximum (hard):

1 click in direction (b)*

* With the adjusting screw fully turned in direction (a)

ECA10100

CAUTION:

Never attempt to turn an adjusting mechanism beyond the maximum or minimum settings.

3. Securely install the rubber caps.

INSTRUMENT AND CONTROL FUNCTIONS

ECA10960

CAUTION:

Be sure to install the rubber caps to prevent dust, etc. from entering the fork legs.

NOTE:

Although the total number of clicks of a damping force adjusting mechanism may not exactly match the above specifications due to small differences in production, the actual number of clicks always represents the entire adjusting range. To obtain a precise adjustment, it would be advisable to check the number of clicks of each damping force adjusting mechanism and to modify the specifications as necessary.

EAU15070

Adjusting the shock absorber assembly

This shock absorber assembly is equipped with a spring preload adjusting nut, a rebound damping force adjusting dial and a compression damping force adjusting knob.

ECA10100

CAUTION:

Never attempt to turn an adjusting mechanism beyond the maximum or minimum settings.

Spring preload

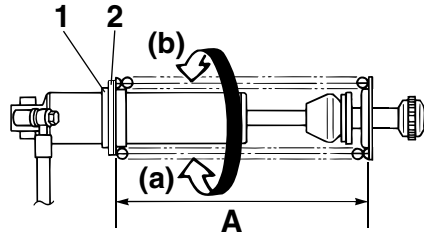

1. Locknut
2. Adjusting nut

1. Loosen the locknut.

2. To increase the spring preload and thereby harden the suspension, turn the adjusting nut in direction (a). To decrease the spring preload and thereby soften the suspension, turn the adjusting nut in direction (b).

NOTE:

- A special wrench is needed to make this adjustment and it can be obtained at a Yamaha dealer.
- The spring preload setting is determined by measuring distance A, shown in the illustration. The shorter the distance A is, the higher the spring preload; the longer distance A is, the lower the spring preload.

Spring preload:

- Minimum (soft):
Distance A = 236 mm (9.3 in)
- Standard:
Distance A = 228 mm (9.0 in)
- Maximum (hard):
Distance A = 224 mm (8.8 in)

3. Tighten the locknut to the specified torque.

INSTRUMENT AND CONTROL FUNCTIONS

Tightening torque:

Locknut:
70 Nm (7.0 m·kgf, 51 ft·lbf)

ECA11240

CAUTION:

Always tighten the locknut against the adjusting nut, and then tighten the locknut to the specified torque.

3

Rebound damping force

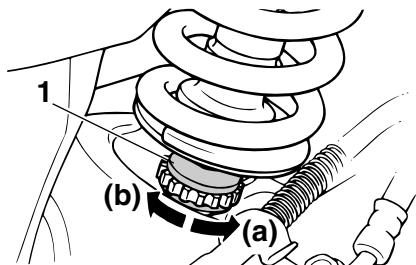

1. Rebound damping force adjusting dial

To increase the rebound damping force and thereby harden the rebound damping, turn the adjusting dial in direction (a). To decrease the rebound damping force and thereby soften the rebound damping, turn the adjusting dial in di-

rection (b).

Rebound damping setting:

Minimum (soft):

16 clicks in direction (b)*

Standard:

8 clicks in direction (b)*

Maximum (hard):

1 click in direction (b)*

* With the adjusting dial fully turned in direction (a)

Compression damping force

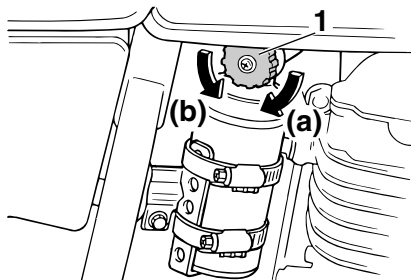

1. Compression damping force adjusting knob

To increase the compression damping force and thereby harden the compression damping, turn the adjusting knob in direction (a). To decrease the com-

pression damping force and thereby soften the compression damping, turn the adjusting knob in direction (b).

Compression damping setting:

Minimum (soft):

5 clicks in direction (a)*

Standard:

11 clicks in direction (a)*

Maximum (hard):

15 clicks in direction (a)*

* With the adjusting knob fully turned in direction (b)

NOTE:

Although the total number of clicks of a damping force adjusting mechanism may not exactly match the above specifications due to small differences in production, the actual number of clicks always represents the entire adjusting range. To obtain a precise adjustment, it would be advisable to check the number of clicks of each damping force adjusting mechanism and to modify the specifications as necessary.

EWA10220

WARNING

This shock absorber contains highly pressurized nitrogen gas. For prop-

er handling, read and understand the following information before handling the shock absorber. The manufacturer cannot be held responsible for property damage or personal injury that may result from improper handling.

- Do not tamper with or attempt to open the gas cylinder.
- Do not subject the shock absorber to an open flame or other high heat sources, otherwise it may explode due to excessive gas pressure.
- Do not deform or damage the gas cylinder in any way, as this will result in poor damping performance.
- Always have a Yamaha dealer service the shock absorber.

EAU15390

Starting circuit cut-off system

The starting circuit cut-off system (comprising the clutch switch and the neutral switch) prevents starting when the transmission is in gear and the clutch lever is not pulled.

Periodically check the operation of the starting circuit cut-off system according to the following procedure.

EWA10250



If a malfunction is noted, have a Yamaha dealer check the system before riding.

INSTRUMENT AND CONTROL FUNCTIONS

3

With the engine turned off:
1. Make sure that the engine stop switch is set to “O”.
2. Turn the key to “ON”.
3. Shift the transmission into the neutral position.
4. Push the start switch.
Does the engine start?

YES NO

5. Turn the engine off.
6. Shift the transmission into gear.
7. Keep the clutch lever pulled.
8. Push the start switch.
Does the engine start?

YES NO

The system is OK. **The motorcycle can be ridden.**

NOTE: _____
This check is most reliable if performed with a warmed-up engine.

The neutral switch may be defective.
The motorcycle should not be ridden until checked by a Yamaha dealer.

The clutch switch may be defective.
The motorcycle should not be ridden until checked by a Yamaha dealer.

PRE-OPERATION CHECKS

EAU15591

The condition of a vehicle is the owner's responsibility. Vital components can start to deteriorate quickly and unexpectedly, even if the vehicle remains unused (for example, as a result of exposure to the elements). Any damage, fluid leakage or loss of tire air pressure could have serious consequences. Therefore, it is very important, in addition to a thorough visual inspection, to check the following points before each ride.

NOTE:

Pre-operation checks should be made each time the vehicle is used. Such an inspection can be accomplished in a very short time; and the added safety it assures is more than worth the time involved.

EWA11150



If any item in the Pre-operation check list is not working properly, have it inspected and repaired before operating the vehicle.

PRE-OPERATION CHECKS

EAU15603

Pre-operation check list

ITEM	CHECKS	PAGE
Fuel	<ul style="list-style-type: none">• Check fuel level in fuel tank.• Refuel if necessary.• Check fuel line for leakage.	3-4
Engine oil	<ul style="list-style-type: none">• Check oil level in engine.• If necessary, add recommended oil to specified level.• Check vehicle for oil leakage.	6-8
Front brake	<ul style="list-style-type: none">• Check operation.• If soft or spongy, have Yamaha dealer bleed hydraulic system.• Check lever free play.• Adjust if necessary.• Check brake pads for wear.• Replace if necessary.• Check fluid level in reservoir.• If necessary, add recommended brake fluid to specified level.• Check hydraulic system for leakage.	6-19, 6-20
Rear brake	<ul style="list-style-type: none">• Check operation.• If soft or spongy, have Yamaha dealer bleed hydraulic system.• Check brake pads for wear.• Replace if necessary.• Check fluid level in reservoir.• If necessary, add recommended brake fluid to specified level.• Check hydraulic system for leakage.	6-19, 6-20
Clutch	<ul style="list-style-type: none">• Check operation.• Lubricate cable if necessary.• Check lever free play.• Adjust if necessary.	6-18
Throttle grip	<ul style="list-style-type: none">• Make sure that operation is smooth.• Check cable free play.• If necessary, have Yamaha dealer adjust cable free play and lubricate cable and grip housing.	6-14, 6-24

PRE-OPERATION CHECKS

ITEM	CHECKS	PAGE
Control cables	<ul style="list-style-type: none"> • Make sure that operation is smooth. • Lubricate if necessary. 	6-23
Drive chain	<ul style="list-style-type: none"> • Check chain slack. • Adjust if necessary. • Check chain condition. • Lubricate if necessary. 	6-21, 6-23
Wheels and tires	<ul style="list-style-type: none"> • Check for damage. • Check tire condition and tread depth. • Check air pressure. • Correct if necessary. 	6-15, 6-17
Brake and shift pedals	<ul style="list-style-type: none"> • Make sure that operation is smooth. • Lubricate pedal pivoting points if necessary. 	6-24
Brake and clutch levers	<ul style="list-style-type: none"> • Make sure that operation is smooth. • Lubricate lever pivoting points if necessary. 	6-24
Sidestand	<ul style="list-style-type: none"> • Make sure that operation is smooth. • Lubricate pivot if necessary. 	6-25
Chassis fasteners	<ul style="list-style-type: none"> • Make sure that all nuts, bolts and screws are properly tightened. • Tighten if necessary. 	—
Instruments, lights, signals and switches	<ul style="list-style-type: none"> • Check operation. • Correct if necessary. 	—
Engine stop switch	<ul style="list-style-type: none"> • Check operation. 	3-1

OPERATION AND IMPORTANT RIDING POINTS

EAU15960

EWA10280

WARNING

- This model is designed for off-road use only. In most instances, it is illegal to ride this model (either day or night) on any public street or highway.
- Never start the engine or operate it in a closed area for any length of time. Exhaust fumes are poisonous, and inhaling them can cause loss of consciousness and death within a short time. Always make sure that there is adequate ventilation.
- Before starting out, make sure that the sidestand is up. If the sidestand is not raised completely, it could contact the ground and distract the operator, resulting in a possible loss of control.

EAU16451

Starting and warming up a cold engine

In order for the starting circuit cut-off system to enable starting, one of the following conditions must be met.

- The transmission is in the neutral position.
- The transmission is in gear with the clutch lever pulled.

EWA11320

WARNING

- Before starting the engine, check the function of the starting circuit cut-off system according to the procedure described on page 3-11.
- Never ride with the sidestand down.

1. Turn the fuel cock lever to "ON".
2. Turn the key to "ON" and make sure that the engine stop switch is set to "○".
3. Shift the transmission into the neutral position.
4. Turn the starter (choke) on and completely close the throttle. (See page 3-6.)

5. Start the engine by pushing the start switch.

NOTE:

If the engine fails to start, release the start switch, wait a few seconds, and then try again. Each starting attempt should be as short as possible to preserve the battery. Do not crank the engine more than 10 seconds on any one attempt.

6. After starting the engine, move the starter (choke) back halfway.

ECA11130

CAUTION:

For maximum engine life, always warm the engine up before starting off. Never accelerate hard when the engine is cold!

7. When the engine is warm, turn the starter (choke) off.

NOTE:

The engine is warm when it responds normally to the throttle with the starter (choke) turned off.

OPERATION AND IMPORTANT RIDING POINTS

EAU16640

Starting a warm engine

Follow the same procedure as for starting a cold engine with the exception that the starter (choke) is not required when the engine is warm.

EAU16671

Shifting

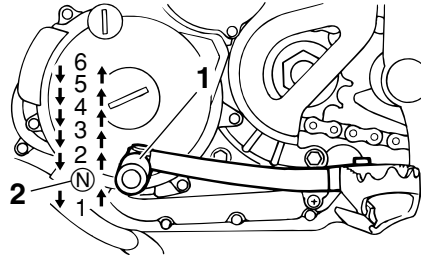

1. Shift pedal
2. Neutral position

Shifting gears lets you control the amount of engine power available for starting off, accelerating, climbing hills, etc.

The gear positions are shown in the illustration.

NOTE: _____

To shift the transmission into the neutral position, press the shift pedal down repeatedly until it reaches the end of its travel, and then slightly raise it.

ECA10260

CAUTION: _____

- Even with the transmission in

the neutral position, do not coast for long periods of time with the engine off, and do not tow the machine for long distances. The transmission is properly lubricated only when the engine is running. Inadequate lubrication may damage the transmission.

- Always use the clutch while changing gears to avoid damaging the engine, transmission, and drive train, which are not designed to withstand the shock of forced shifting.

OPERATION AND IMPORTANT RIDING POINTS

5

EAU16850

Engine break-in

There is never a more important period in the life of your engine than the first 20 hours of riding. For this reason, you should read the following material carefully.

Since the engine is brand new, do not put an excessive load on it for the first 20 hours of operation. The various parts in the engine wear and polish themselves to the correct operating clearances. During this period, prolonged full-throttle operation or any condition that might result in engine overheating must be avoided. However, momentary full-throttle operation under load (i.e., two to three seconds maximum) does not harm the engine. Each full-throttle acceleration should be followed with a substantial rest period for the engine. To allow the engine to cool down from the temporary build-up of heat, cruise at a lower engine speed.

0–10 hours

- Avoid prolonged operation above 1/2 throttle.

- After every hour of operation, stop the engine, and then let it cool for five to ten minutes.
- Vary the engine speed from time to time. Do not operate the engine at one set throttle position.

10–20 hours

- Avoid prolonged operation above 3/4 throttle.
- Rev the engine freely through the gears, but do not use full throttle at any time.

After break-in

Avoid prolonged full-throttle operation. Vary the engine speed occasionally.

ECA10270

CAUTION:

If any engine trouble should occur during the engine break-in period, immediately have a Yamaha dealer check the vehicle.

EAU17170

Parking

When parking, stop the engine, remove the key from the main switch, and then turn the fuel cock lever to “OFF”.

EWA10310

WARNING

- **Since the engine and exhaust system can become very hot, park in a place where pedestrians or children are not likely to touch them.**
- **Do not park on a slope or on soft ground, otherwise the vehicle may overturn.**

PERIODIC MAINTENANCE AND MINOR REPAIR

EAU17291

Safety is an obligation of the owner. Periodic inspection, adjustment and lubrication will keep your vehicle in the safest and most efficient condition possible. The most important points of vehicle inspection, adjustment, and lubrication are explained on the following pages.

EWA10320



If you are not familiar with maintenance work, have a Yamaha dealer do it for you.

EAU17310

Owner's tool kit

The service information included in this manual and the tools provided in the owner's tool kit are intended to assist you in the performance of preventive maintenance and minor repairs. However, additional tools such as a torque wrench may be necessary to perform certain maintenance work correctly.

NOTE: _____

If you do not have the tools or experience required for a particular job, have a Yamaha dealer perform it for you.

EWA10340



Modifications not approved by Yamaha may cause loss of performance, excessive emissions, and render the vehicle unsafe for use. Consult a Yamaha dealer before attempting any changes.

PERIODIC MAINTENANCE AND MINOR REPAIR

EAU35230

Periodic maintenance chart for the emission control system

NOTE:

- From 1800 mi (3000 km) or 18 months, repeat the maintenance intervals starting from 600 mi (1000 km) or 6 months.
- Items marked with an asterisk should be performed by a Yamaha dealer as they require special tools, data and technical skills.

No.	ITEM	CHECKS AND MAINTENANCE JOBS	INITIAL	EVERY	
			100 mi (150 km) or 1 month	600 mi (1000 km) or 6 months	1200 mi (2000 km) or 12 months
1	* Fuel line	<ul style="list-style-type: none"> • Check fuel hoses for cracks or damage. • Replace if necessary. 		√	√
2	Spark plug	<ul style="list-style-type: none"> • Check condition. • Adjust gap and clean. 		√	√
3	* Valve clearance	<ul style="list-style-type: none"> • Check and adjust valve clearance when engine is cold. 			√
4	* Air filter element	<ul style="list-style-type: none"> • Clean with solvent. • Replace if necessary. 		√	√
5	* Crankcase breather system	<ul style="list-style-type: none"> • Check ventilation hose for cracks or damage and drain any deposits. • Replace if necessary. 		√	√
6	* Carburetor	<ul style="list-style-type: none"> • Check engine idling speed and starter operation. • Adjust if necessary. 	√	√	√
7	Exhaust system	<ul style="list-style-type: none"> • Check for leakage. • Tighten if necessary. • Replace gasket(s) if necessary. 		√	√
8	Engine oil	<ul style="list-style-type: none"> • Change (warm engine before draining). • Change. (Warm engine before draining.) 	√	√	√
9	Engine oil filter element	<ul style="list-style-type: none"> • Clean. 	√	√	√

PERIODIC MAINTENANCE AND MINOR REPAIR

EAU35340

General maintenance and lubrication chart

No.	ITEM	CHECKS AND MAINTENANCE JOBS	INITIAL	EVERY	
			100 mi (150 km) or 1 month	600 mi (1000 km) or 6 months	1200 mi (2000 km) or 12 months
1	Clutch	<ul style="list-style-type: none"> • Check operation. • Adjust or replace cable. 	✓	✓	✓
2	* Front brake	<ul style="list-style-type: none"> • Check operation, fluid level, and for fluid leakage. • Replace brake pads if necessary. 	✓	✓	✓
3	* Rear brake	<ul style="list-style-type: none"> • Check operation, fluid level, and for fluid leakage. • Replace brake pads if necessary. 	✓	✓	✓
4	* Brake hoses	<ul style="list-style-type: none"> • Check for cracks or damage. • Replace. 		Every 4 years	
5	* Wheels	<ul style="list-style-type: none"> • Check runout, spoke tightness and for damage. • Tighten spokes if necessary. 	✓	✓	✓
6	* Tires	<ul style="list-style-type: none"> • Check tread depth and for damage. • Replace if necessary. • Check air pressure. • Correct if necessary. 		✓	✓
7	* Wheel bearings	<ul style="list-style-type: none"> • Check bearings for smooth operation. • Replace if necessary. 		✓	✓
8	* Swingarm pivot bearings	<ul style="list-style-type: none"> • Check bearing assemblies for looseness. • Moderately repack with lithium-soap-based grease. 		✓	✓
9	Drive chain	<ul style="list-style-type: none"> • Check chain slack/alignment and condition. • Adjust and lubricate chain with a special O-ring chain lubricant thoroughly. 	Every ride		
10	* Steering bearings	<ul style="list-style-type: none"> • Check bearing assemblies for looseness. • Moderately repack with lithium-soap-based grease every 1200 mi (2000 km) or 12 months (whichever comes first). 	✓		✓

PERIODIC MAINTENANCE AND MINOR REPAIR

No.	ITEM	CHECKS AND MAINTENANCE JOBS	INITIAL	EVERY	
			100 mi (150 km) or 1 month	600 mi (1000 km) or 6 months	1200 mi (2000 km) or 12 months
11	* Chassis fasteners	<ul style="list-style-type: none"> • Check all chassis fitting and fasteners. • Correct if necessary. 	√	√	√
12	Brake and clutch lever pivot shafts	<ul style="list-style-type: none"> • Apply lithium-soap-based grease (all-purpose grease) lightly. 		√	√
13	Brake and shift pedal pivot shafts	<ul style="list-style-type: none"> • Apply lithium-soap-based grease (all-purpose grease) lightly. 		√	√
14	Sidestand pivot	<ul style="list-style-type: none"> • Check operation. • Apply lithium-soap-based grease (all-purpose grease) lightly. 	√		√
15	* Spark arrester	<ul style="list-style-type: none"> • Clean. 			√
16	* Front fork	<ul style="list-style-type: none"> • Check operation and for oil leakage. • Replace if necessary. 		√	√
17	* Shock absorber assembly	<ul style="list-style-type: none"> • Check operation and for oil leakage. • Replace if necessary. 			√
18	* Rear suspension link pivots	<ul style="list-style-type: none"> • Apply molybdenum disulfide grease lightly. 			√
19	* Control and meter cables	<ul style="list-style-type: none"> • Apply Yamaha chain and cable lube or engine oil 10W-30 thoroughly. 	√	√	√
20	* Throttle grip housing and cable	<ul style="list-style-type: none"> • Check operation and free play. • Adjust the throttle cable free play if necessary. • Lubricate the throttle grip housing and cable. 	√	√	√

PERIODIC MAINTENANCE AND MINOR REPAIR

EAU18670

NOTE:

- The air filter needs more frequent service if you are riding in unusually wet or dusty areas.
 - Hydraulic brake service
 - Regularly check and, if necessary, correct the brake fluid level.
 - Every two years replace the internal components of the brake master cylinders and calipers, and change the brake fluid.
 - Replace the brake hoses every four years and if cracked or damaged.
-

PERIODIC MAINTENANCE AND MINOR REPAIR

EAU18721

Removing and installing the cowling and panels

The cowling and panels shown need to be removed to perform some of the maintenance jobs described in this chapter. Refer to this section each time the cowling or a panel needs to be removed and installed.

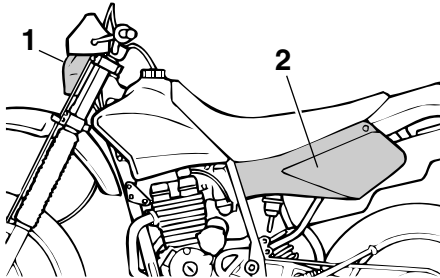

1. Cowling A
2. Panel A

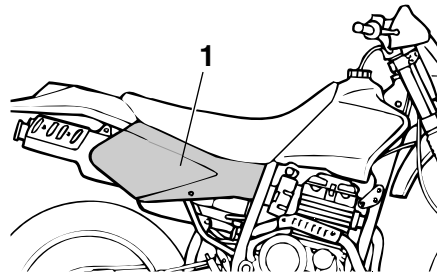

1. Panel B

Cowling A

EAU18850

To remove the cowling
Remove the cowling screws, and then pull the cowling off as shown.

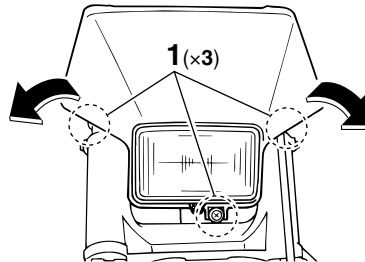

1. Screw

To install the cowling

Place the cowling in the original position, and then install the screws.

Panels A and B

EAU19292

To remove one of the panels

Remove the screw, and then pull the panel off as shown.

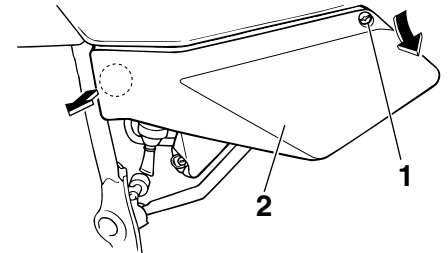

1. Screw
2. Panel A

PERIODIC MAINTENANCE AND MINOR REPAIR

EAU19602

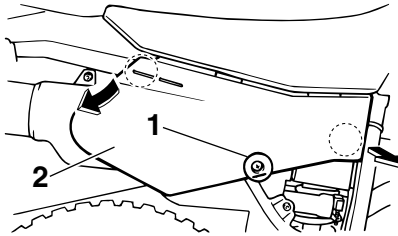

1. Screw
2. Panel B

To install the panel

Place the panel in the original position, and then install the screw.

Checking the spark plug

The spark plug is an important engine component, which is easy to check. Since heat and deposits will cause any spark plug to slowly erode, the spark plug should be removed and checked in accordance with the periodic maintenance and lubrication chart. In addition, the condition of the spark plug can reveal the condition of the engine.

To remove the spark plug

1. Remove the spark plug cap.

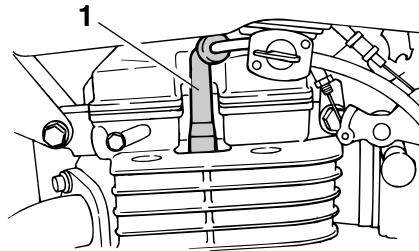

1. Spark plug cap
2. Remove the spark plug as shown, with the spark plug wrench included in the owner's tool kit.

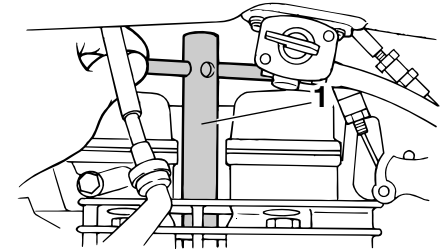

1. Spark plug wrench

To check the spark plug

1. Check that the porcelain insulator around the center electrode of the spark plug is a medium-to-light tan (the ideal color when the vehicle is ridden normally).

NOTE:

If the spark plug shows a distinctly different color, the engine could be defective. Do not attempt to diagnose such problems yourself. Instead, have a Yamaha dealer check the vehicle.

2. Check the spark plug for electrode erosion and excessive carbon or other deposits, and replace it if necessary.

PERIODIC MAINTENANCE AND MINOR REPAIR

EAU19784

Specified spark plug:
NGK/CR9E
DENSO/U27ESR-N

To install the spark plug

1. Measure the spark plug gap with a wire thickness gauge and, if necessary, adjust the gap to specification.

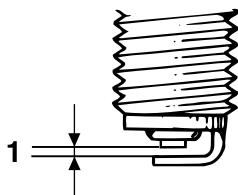

1. Spark plug gap

Spark plug gap:
0.7–0.8 mm (0.028–0.031 in)

2. Clean the surface of the spark plug gasket and its mating surface, and then wipe off any grime from the spark plug threads.

3. Install the spark plug with the spark plug wrench, and then tighten it to the specified torque.

Tightening torque:
Spark plug:
12.5 Nm (1.25 m·kgf, 9.0 ft·lbf)

NOTE:

If a torque wrench is not available when installing a spark plug, a good estimate of the correct torque is 1/4–1/2 turn past finger tight. However, the spark plug should be tightened to the specified torque as soon as possible.

4. Install the spark plug cap.

Engine oil and oil filter element

The engine oil level should be checked before each ride. In addition, the oil must be changed and the oil filter element cleaned at the intervals specified in the General maintenance and lubrication chart.

To check the engine oil level

1. Place the vehicle on a level surface and hold it in an upright position.

NOTE:

Make sure that the vehicle is positioned straight up when checking the oil level. A slight tilt to the side can result in a false reading.

2. Start the engine, warm it up for several minutes, and then turn it off.
3. Wait a few minutes until the oil settles, and then check the oil level through the check window located at the bottom-right side of the crankcase.

PERIODIC MAINTENANCE AND MINOR REPAIR

NOTE: _____

The engine oil should be between the minimum and maximum level marks.

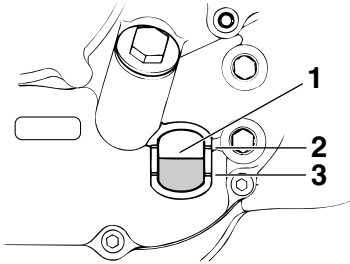

1. Engine oil level check window
2. Maximum level mark
3. Minimum level mark

4. If the engine oil is below the minimum level mark, add sufficient oil of the recommended type to raise it to the correct level.

To change the engine oil (with or without oil filter element cleaning)

1. Start the engine, warm it up for several minutes, and then turn it off.
2. Place an oil pan under the engine

to collect the used oil.

3. Remove the engine oil filler bolt and drain bolt to drain the oil from the crankcase.

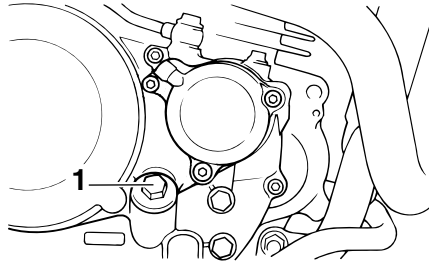

1. Engine oil filler bolt

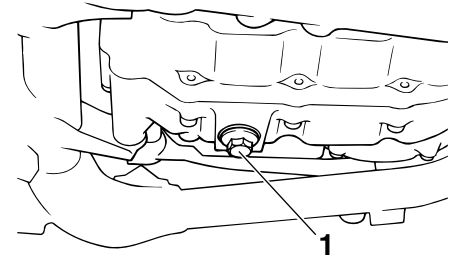

1. Engine oil drain bolt

NOTE: _____

Check each washer for damage and replace them if necessary.

4. Remove the oil filter element drain bolt to drain the oil from the oil filter element.

PERIODIC MAINTENANCE AND MINOR REPAIR

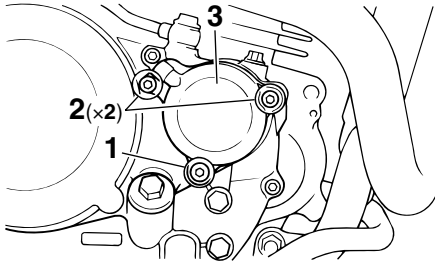

- 1. Oil filter element drain bolt
- 2. Bolt
- 3. Oil filter element cover

NOTE: _____
Skip steps 5–9 if the oil filter element is not being cleaned.

- 5. Remove the oil filter element cover by removing the bolts.
- 6. Remove the oil filter element and O-rings.

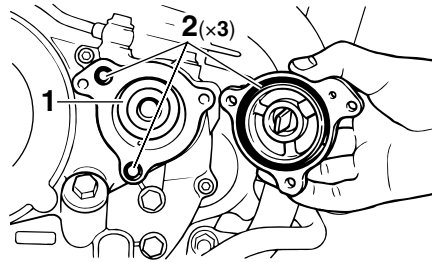

- 1. Oil filter element
 - 2. O-ring
- 7. Check the O-rings for damage and replace them if necessary.
 - 8. Clean the oil filter element with solvent, and then install it.

NOTE: _____
Check the oil filter element for damage and replace it if necessary.

- 9. Install the oil filter element cover by installing the bolts, then tightening them to the specified torque.

Tightening torque:

Oil filter element cover bolt:
10 Nm (1.0 m·kgf, 7.2 ft·lbf)

NOTE: _____
Make sure that the O-rings are properly seated.

- 10. Install the engine oil drain bolt, and then tighten it to the specified torque.
- 11. Install the engine oil filter element drain bolt, and then tighten it to the specified torque.

Tightening torques:

Engine oil drain bolt:
20 Nm (2.0 m·kgf, 14.5 ft·lbf)
Oil filter element drain bolt:
10 Nm (1.0 m·kgf, 7.2 ft·lbf)

- 12. Add the specified amount of the recommended engine oil, and then install and tighten the oil filler cap.

PERIODIC MAINTENANCE AND MINOR REPAIR

Recommended oil:

See page 8-1.

Oil quantity:

Without oil filter element replacement:

1.10 L (1.16 US qt) (0.97 Imp.qt)

With oil filter element replacement:

1.20 L (1.27 US qt) (1.06 Imp.qt)

ECA11620

CAUTION:

- In order to prevent clutch slippage (since the engine oil also lubricates the clutch), do not mix any chemical additives. Do not use oils with a diesel specification of “CD” or oils of a higher quality than specified. In addition, do not use oils labeled “ENERGY CONSERVING II” or higher.
- Make sure that no foreign material enters the crankcase.

13. Start the engine, and then let it idle for several minutes while checking it for oil leakage. If oil is leaking, immediately turn the engine off and check for the cause.
14. Turn the engine off, and then

check the oil level and correct it if necessary.

ECA10970

CAUTION:

After replacing the engine oil, make sure to check the oil pressure as described below.

- Remove the bleed bolt from the engine oil filter element cover.
- Start the engine and keep it idling until oil flows out. If no oil comes out after one minute, turn the engine off immediately so it will not seize. If this occurs, have a Yamaha dealer repair the vehicle.
- After checking the oil pressure, tighten the bleed bolt to the specified torque.

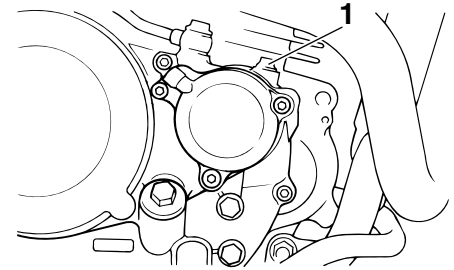

1. Bleed bolt

Tightening torque:

Bleed bolt:

7 Nm (0.7 m·kgf, 5.0 ft·lbf)

PERIODIC MAINTENANCE AND MINOR REPAIR

EAU20890

Cleaning the air filter element

The air filter element should be cleaned at the intervals specified in the periodic maintenance and lubrication chart. Clean the air filter element more frequently if you are riding in unusually wet or dusty areas.

1. Remove panel A. (See page 6-6.)
2. Remove the air filter case cover by removing the holding clips.

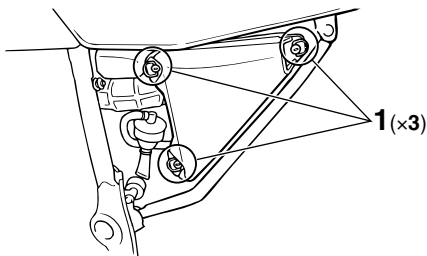

1. Holding clip

3. Pull the air filter element out of the air filter case.

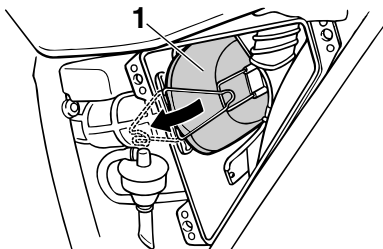

1. Air filter element

4. Remove the sponge material from the air filter element frame.

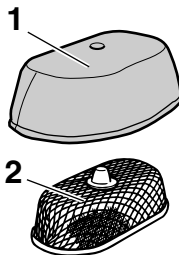

1. Sponge material
2. Air filter element frame

5. Clean the sponge material with solvent, and then squeeze the remaining solvent out.

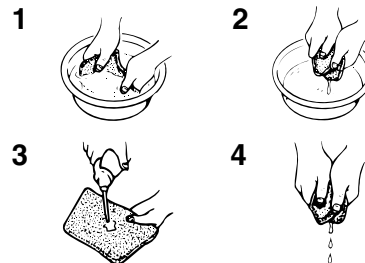

6. Apply oil of the recommended type to the entire surface of the sponge material, and then squeeze the excess oil out.

NOTE: _____
The sponge material should be wet but not dripping.

Recommended oil:

Yamaha foam air filter oil or other quality air filter oil

7. Install the sponge material onto the frame, insert the air filter element into the air filter case, and then install the air filter case cover by installing the holding clips.

PERIODIC MAINTENANCE AND MINOR REPAIR

ECA10480

EAU21241

CAUTION:

- Make sure that the air filter element is properly seated in the air filter case.
- The engine should never be operated without the air filter element installed, otherwise the piston(s) and/or cylinder(s) may become excessively worn.

8. Install the panel.

Cleaning the spark arrester

The spark arrester should be cleaned at the intervals specified in the periodic maintenance and lubrication chart.

NOTE:

Make sure to select a well-ventilated area free of combustible materials to clean the spark arrester.

1. Remove the tailpipe by removing the bolts, and then pulling it out of the muffler.

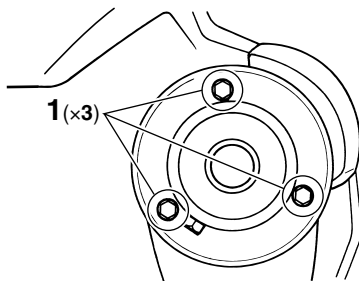

1. Bolt

2. Tap the tailpipe lightly, and then use a wire brush to remove any carbon deposits from the spark arrester portion of the tailpipe and in-

side of the tailpipe housing.

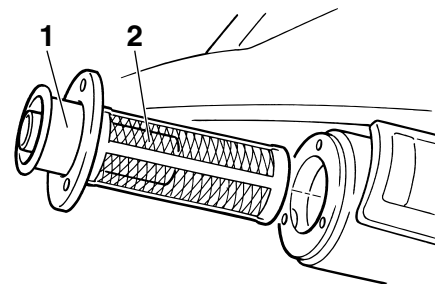

1. Tailpipe
2. Spark arrester

3. Insert the tailpipe into the muffler, and then install and tighten the bolts.

NOTE:

Make sure to align the bolt holes when inserting the tailpipe.

4. Remove the purging bolt.

PERIODIC MAINTENANCE AND MINOR REPAIR

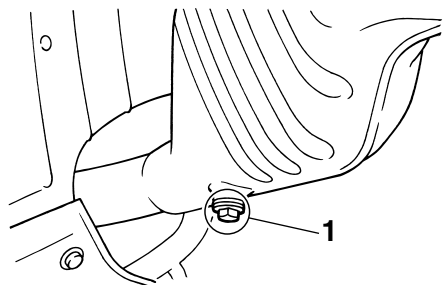

1. Purging bolt

5. Start the engine and rev it approximately twenty times while momentarily creating exhaust system back pressure using a shop towel to block the end of the muffler.
6. Stop the engine and allow the exhaust pipe to cool.
7. Install the purging bolt and tighten it.

EAU21251

Carburetor

The carburetor is an important part of the engine and its emission control system, which requires very sophisticated adjustment. Therefore, carburetor adjustments should be left to Yamaha dealer, who has the necessary professional knowledge and experience.

EAU21381

Checking the throttle cable free play

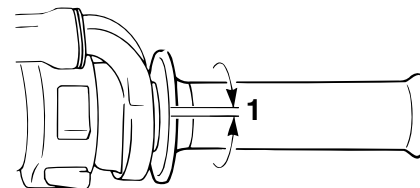

1. Throttle cable free play

The throttle cable free play should measure 3.0–5.0 mm (0.12–0.20 in) at the throttle grip. Periodically check the throttle cable free play and, if necessary, have a Yamaha dealer adjust it.

PERIODIC MAINTENANCE AND MINOR REPAIR

EAU21401

Valve clearance

The valve clearance changes with use, resulting in improper air-fuel mixture and/or engine noise. To prevent this from occurring, the valve clearance must be adjusted by a Yamaha dealer at the intervals specified in the periodic maintenance and lubrication chart.

EAU35830

Tires

To maximize the performance, durability, and safe operation of your machine, note the following points regarding the specified tires.

Tire air pressure

The tire air pressure should be checked and, if necessary, adjusted before each ride.

EWA10440

WARNING

- The tire air pressure must be checked and adjusted on cold tires (i.e., when the temperature of the tires equals the ambient temperature).
- The tire air pressure must be adjusted in accordance with the riding speed and with the total weight of rider, cargo, and accessories approved for this model.

Off-road riding:

Front:

100 kPa (15 psi) (1.00 kgf/cm²)

Rear:

100 kPa (15 psi) (1.00 kgf/cm²)

Maximum load*:

90 kg (198 lb)

* Total weight of rider, cargo and accessories

EWA10450

WARNING

Because loading has an enormous impact on the handling, braking, performance and safety characteristics of your vehicle, you should keep the following precautions in mind.

- **NEVER OVERLOAD THE VEHICLE!** Operation of an overloaded vehicle may result in tire damage, loss of control, or severe injury. Make sure that the total weight of rider, cargo, and accessories does not exceed the specified maximum load for the vehicle.
- Do not carry along loosely packed items, which can shift

6

PERIODIC MAINTENANCE AND MINOR REPAIR

during a ride.

- Securely pack the heaviest items close to the center of the vehicle and distribute the weight evenly on both sides.
- Adjust the suspension and tire air pressure with regard to the load.
- Check the tire condition and air pressure before each ride.

Tire inspection

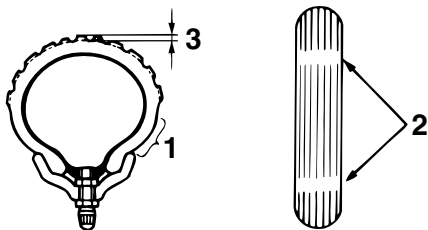

1. Tire sidewall
2. Tire wear indicator
3. Tire tread depth

The tires must be checked before each ride. If a tire tread shows crosswise lines (minimum tread depth), if the tire

has a nail or glass fragments in it, or if the sidewall is cracked, have a Yamaha dealer replace the tire immediately.

Minimum tire tread depth (front and rear):
4.0 mm (0.16 in)

Tire information

This machine is equipped with spoke wheels and tube tires.

EWA10460

WARNING

- The front and rear tires should be of the same make and design, otherwise the handling characteristics of the vehicle cannot be guaranteed.
- After extensive tests, only the tires listed below have been approved for this model by Yamaha Motor Co., Ltd.

Front tire:

Size:
80/100-21 51M
Manufacturer/model:
DUNLOP/D739FA

Rear tire:

Size:
100/100-18 59M
Manufacturer/model:
DUNLOP/D739

EWA10570

WARNING

- Have a Yamaha dealer replace excessively worn tires. Besides being illegal, operating the machine with excessively worn tires decreases riding stability and can lead to loss of control.
- The replacement of all wheel- and brake-related parts, including the tires, should be left to a Yamaha dealer, who has the necessary professional knowledge and experience.
- It is not recommended to patch a punctured tube. If unavoidable, however, patch the tube very carefully and replace it as soon as possible with a

high-quality product.

EAU21940

Spoke wheels

To maximize the performance, durability, and safe operation of your machine, note the following points regarding the specified wheels.

- The wheel rims should be checked for cracks, bends or warpage, and the spokes for looseness or damage before each ride. If any damage is found, have a Yamaha dealer replace the wheel. Do not attempt even the smallest repair to the wheel. A deformed or cracked wheel must be replaced.
- The wheel should be balanced whenever either the tire or wheel has been changed or replaced. An unbalanced wheel can result in poor performance, adverse handling characteristics, and a shortened tire life.
- Ride at moderate speeds after changing a tire since the tire surface must first be “broken in” for it to develop its optimal characteristics.

EAU2011

Accessories and replacement parts

EWA10621



This vehicle is not designed to pull a trailer or to be attached to a sidecar. The accessories or replacement parts you choose for your vehicle should be designed specifically for this model, and they must be securely mounted to maintain the inherent stability of the original design. Genuine Yamaha Parts and Accessories are designed and tested to be compatible with your vehicle. Please consider Genuine Yamaha Parts and Accessories before making a purchase. Use of non-Yamaha-approved accessories or replacement parts may cause loss of handling stability and riding safety. Since Yamaha cannot control the quality of accessories or parts manufactured by other companies, Yamaha cannot be held liable for any consequences caused by the use of items which have not

PERIODIC MAINTENANCE AND MINOR REPAIR

been approved by Yamaha.

EAU22030

Adjusting the clutch lever free play

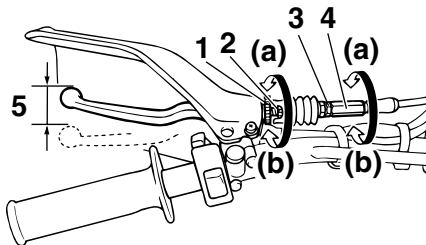

1. Locknut (clutch lever)
2. Adjusting bolt
3. Locknut (clutch cable)
4. Adjusting nut
5. Clutch lever free play

The clutch lever free play should measure 10.0–15.0 mm (0.39–0.59 in) as shown. Periodically check the clutch lever free play and, if necessary, adjust it as follows.

1. Loosen the locknut at the clutch lever.
2. To increase the clutch lever free play, turn the adjusting bolt in direction (a). To decrease the clutch

lever free play, turn the adjusting bolt in direction (b).

3. If the specified clutch lever free play could be obtained as described above, tighten the locknut and skip the rest of the procedure, otherwise proceed as follows.
4. Fully turn the adjusting bolt in direction (a) to loosen the clutch cable.
5. Loosen the locknut further down the clutch cable.
6. To increase the clutch lever free play, turn the adjusting nut in direction (a). To decrease the clutch lever free play, turn the adjusting nut in direction (b).
7. Tighten both locknuts.

Adjusting the brake lever free play

EAU22092

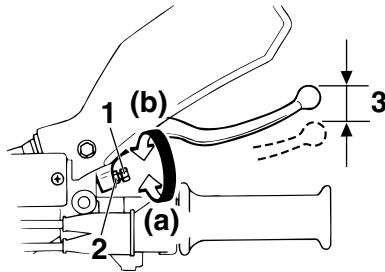

1. Brake lever free play adjusting screw
2. Locknut
3. Brake lever free play

The brake lever free play should measure 2.0–5.0 mm (0.08–0.20 in) as shown. Periodically check the brake lever free play and, if necessary, adjust it as follows.

1. Loosen the locknut at the brake lever.
2. To increase the brake lever free play, turn the adjusting screw in direction (a). To decrease the brake lever free play, turn the adjusting screw in direction (b).

3. Tighten the locknut.

EWA10630

! WARNING

- After adjusting the brake lever free play, check the free play and make sure that the brake is working properly.
- A soft or spongy feeling in the brake lever can indicate the presence of air in the hydraulic system. If there is air in the hydraulic system, have a Yamaha dealer bleed the system before operating the machine. Air in the hydraulic system will diminish the braking performance, which may result in loss of control and an accident.

Checking the front and rear brake pads

EAU22311

Front brake

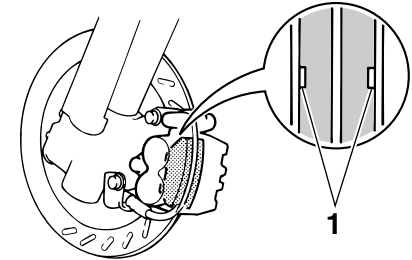

1. Wear indicator

Rear brake

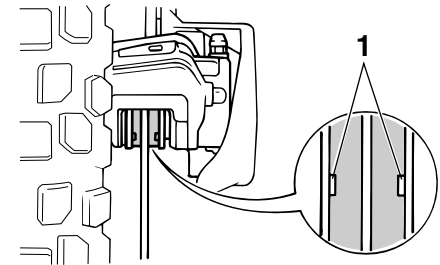

1. Wear indicator

PERIODIC MAINTENANCE AND MINOR REPAIR

The front and rear brake pads must be checked for wear at the intervals specified in the periodic maintenance and lubrication chart. Each brake pad is provided with a wear indicator, which allows you to check the brake pad wear without having to disassemble the brake. To check the brake pad wear, check the position of the wear indicator while applying the brake. If a brake pad has worn to the point that the wear indicator almost touches the brake disc, have a Yamaha dealer replace the brake pads as a set.

Checking the brake fluid level EAU22580

Front brake

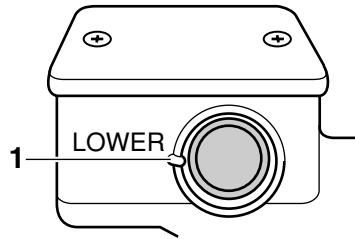

1. Minimum level mark

Rear brake

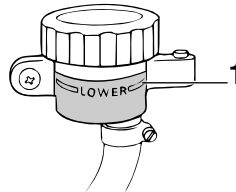

1. Minimum level mark

Insufficient brake fluid may allow air to

enter the brake system, possibly causing it to become ineffective.

Before riding, check that the brake fluid is above the minimum level mark and replenish if necessary. A low brake fluid level may indicate worn brake pads and/or brake system leakage. If the brake fluid level is low, be sure to check the brake pads for wear and the brake system for leakage.

Observe these precautions:

- When checking the fluid level, make sure that the top of the brake fluid reservoir is level.
- Use only the recommended quality brake fluid, otherwise the rubber seals may deteriorate, causing leakage and poor braking performance.

Recommended brake fluid:

DOT 4

- Refill with the same type of brake fluid. Mixing fluids may result in a harmful chemical reaction and lead to poor braking performance.
- Be careful that water does not enter the brake fluid reservoir when

PERIODIC MAINTENANCE AND MINOR REPAIR

refilling. Water will significantly lower the boiling point of the fluid and may result in vapor lock.

- Brake fluid may deteriorate painted surfaces or plastic parts. Always clean up spilled fluid immediately.
- As the brake pads wear, it is normal for the brake fluid level to gradually go down. However, if the brake fluid level goes down suddenly, have a Yamaha dealer check the cause.

EAU22730

Changing the brake fluid

Have a Yamaha dealer change the brake fluid at the intervals specified in the NOTE after the periodic maintenance and lubrication chart. In addition, have the oil seals of the master cylinders and calipers as well as the brake hoses replaced at the intervals listed below or whenever they are damaged or leaking.

- Oil seals: Replace every two years.
- Brake hoses: Replace every four years.

EAU22760

Drive chain slack

The drive chain slack should be checked before each ride and adjusted if necessary.

EAU22771

To check the drive chain slack

1. Place the machine on the side-stand.

NOTE:

When checking and adjusting the drive chain slack, there should be no weight on the machine.

2. Shift the transmission into the neutral position.
3. Move the rear wheel by pushing the machine to locate the tightest portion of the drive chain, and then measure the drive chain slack as shown.

Drive chain slack:

35.0–50.0 mm (1.38–1.97 in)

PERIODIC MAINTENANCE AND MINOR REPAIR

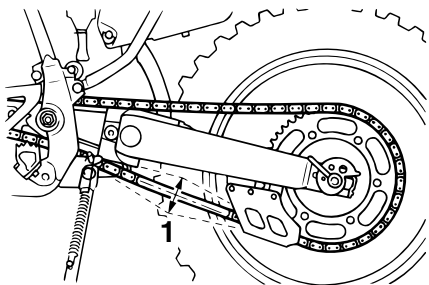

1. Drive chain slack

4. If the drive chain slack is incorrect, adjust it as follows.

EAU22910

To adjust the drive chain slack

1. Remove the cotter pin from the axle nut, and then loosen the axle nut.
2. To tighten the drive chain, turn the adjusting plate on each side of the swingarm in direction (a). To loosen the drive chain, turn the adjusting plate on each side of the swingarm in direction (b), and then push the rear wheel forward.

NOTE: _____
Make sure that both adjusting plates

are in the same position for proper wheel alignment.

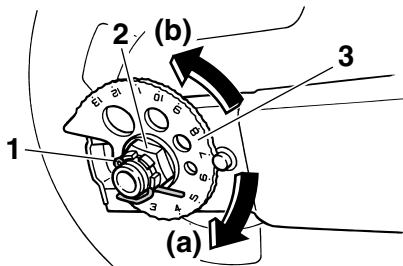

1. Cotter pin
2. Axle nut
3. Adjusting plate

ECA10570

CAUTION:

Improper drive chain slack will overload the engine as well as other vital parts of the machine and can lead to chain slippage or breakage. To prevent this from occurring, keep the drive chain slack within the specified limits.

3. Tighten the axle nut to the specified torque.

Tightening torque:

Axle nut:
105 Nm (10.5 m·kgf, 76 ft·lbf)

4. Insert a new cotter pin into the axle nut, and then bend its ends as shown.

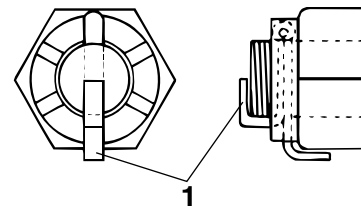

1. Cotter pin

NOTE:

Make sure that two notches in the axle nut are aligned with the hole through the wheel axle, otherwise further tighten the axle nut until they are.

EWA10700

WARNING

Always use a new cotter pin for the axle nut.

PERIODIC MAINTENANCE AND MINOR REPAIR

EAU23022

Cleaning and lubricating the drive chain

The drive chain must be cleaned and lubricated at the intervals specified in the periodic maintenance and lubrication chart, otherwise it will quickly wear out, especially when riding in dusty or wet areas. Service the drive chain as follows.

ECA10581

CAUTION:

The drive chain must be lubricated after washing the machine and riding in the rain.

1. Clean the drive chain with kerosene and a small soft brush.

ECA11120

CAUTION:

To prevent damaging the O-rings, do not clean the drive chain with steam cleaners, high-pressure washers or inappropriate solvents.

2. Wipe the drive chain dry.
3. Thoroughly lubricate the drive chain with a special O-ring chain lubricant.

ECA11110

CAUTION:

Do not use engine oil or any other lubricants for the drive chain, as they may contain substances that could damage the O-rings.

EAU23090

Checking and lubricating the cables

The operation of all control cables and the condition of the cables should be checked before each ride, and the cables and cable ends should be lubricated if necessary. If a cable is damaged or does not move smoothly, have a Yamaha dealer check or replace it.

Recommended lubricant:

Yamaha Chain and Cable Lube or engine oil SAE 10W-30 (API SE)

EWA10710

WARNING

Damage to the outer housing of cables may result in internal rusting and cause interference with cable movement. Replace damaged cables as soon as possible to prevent unsafe conditions.

PERIODIC MAINTENANCE AND MINOR REPAIR

EAU23111

Checking and lubricating the throttle grip and cable

The operation of the throttle grip should be checked before each ride. In addition, the cable should be lubricated at the intervals specified in the periodic maintenance chart.

Checking and lubricating the brake and clutch levers

EAU23140

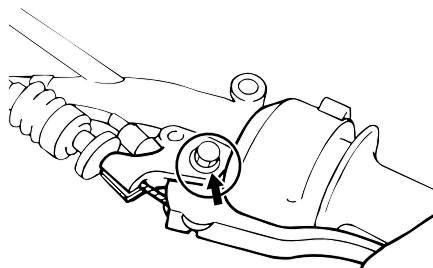

The operation of the brake and clutch levers should be checked before each ride, and the lever pivots should be lubricated if necessary.

Recommended lubricant:

Lithium-soap-based grease (all-purpose grease)

EAU23180

Lubricating the brake pedal

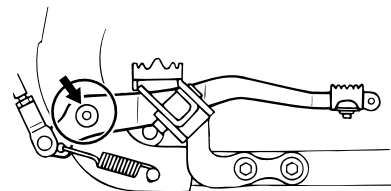

The operation of the brake pedal should be checked before each ride, and the pedal pivot should be lubricated if necessary.

Recommended lubricant:

Lithium-soap-based grease (all-purpose grease)

Checking and lubricating the sidestand

EAU23200

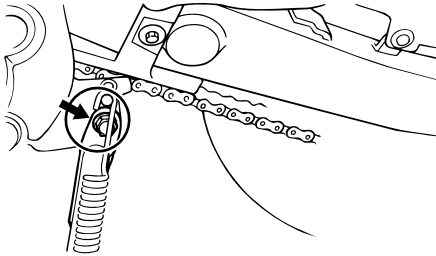

The operation of the sidestand should be checked before each ride, and the sidestand pivot and metal-to-metal contact surfaces should be lubricated if necessary.

EWA10730

WARNING

If the sidestand does not move up and down smoothly, have a Yamaha dealer check or repair it.

Recommended lubricant:

Lithium-soap-based grease (all-purpose grease)

Checking the front fork

EAU23271

The condition and operation of the front fork must be checked as follows at the intervals specified in the periodic maintenance and lubrication chart.

To check the condition

EWA10750

WARNING

Securely support the vehicle so that there is no danger of it falling over.

Check the inner tubes for scratches, damage and excessive oil leakage.

To check the operation

1. Place the vehicle on a level surface and hold it in an upright position.
2. While applying the front brake, push down hard on the handlebars several times to check if the front fork compresses and rebounds smoothly.

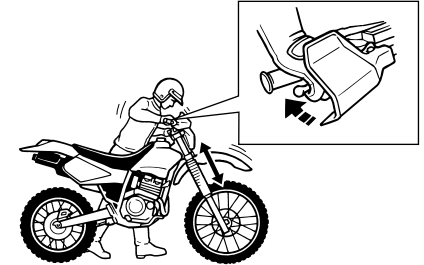

ECA10590

CAUTION:

If any damage is found or the front fork does not operate smoothly, have a Yamaha dealer check or repair it.

PERIODIC MAINTENANCE AND MINOR REPAIR

EAU23280

Checking the steering

Worn or loose steering bearings may cause danger. Therefore, the operation of the steering must be checked as follows at the intervals specified in the periodic maintenance and lubrication chart.

1. Place a stand under the engine to raise the front wheel off the ground.

EWA10750

WARNING

Securely support the vehicle so that there is no danger of it falling over.

2. Hold the lower ends of the front fork legs and try to move them forward and backward. If any free play can be felt, have a Yamaha dealer check or repair the steering.

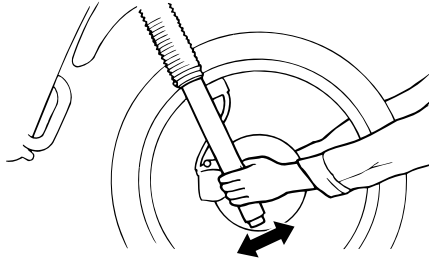

EAU23290

Checking the wheel bearings

The front and rear wheel bearings must be checked at the intervals specified in the periodic maintenance and lubrication chart. If there is play in the wheel hub or if the wheel does not turn smoothly, have a Yamaha dealer check the wheel bearings.

PERIODIC MAINTENANCE AND MINOR REPAIR

Battery

EAU23380

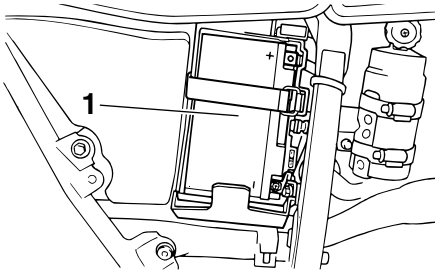

1. Battery

The battery is located behind panel B. (See page 6-6.)

This model is equipped with a sealed-type (MF) battery, which does not require any maintenance. There is no need to check the electrolyte or to add distilled water.

ECA10620

CAUTION:

Never attempt to remove the battery cell seals, as this would permanently damage the battery.

EWA10760

WARNING

- Electrolyte is poisonous and

dangerous since it contains sulfuric acid, which causes severe burns. Avoid any contact with skin, eyes or clothing and always shield your eyes when working near batteries. In case of contact, administer the following FIRST AID.

- **EXTERNAL:** Flush with plenty of water.
- **INTERNAL:** Drink large quantities of water or milk and immediately call a physician.
- **EYES:** Flush with water for 15 minutes and seek prompt medical attention.
- **Batteries produce explosive hydrogen gas. Therefore, keep sparks, flames, cigarettes, etc., away from the battery and provide sufficient ventilation when charging it in an enclosed space.**
- **KEEP THIS AND ALL BATTERIES OUT OF THE REACH OF CHILDREN.**

To charge the battery

Have a Yamaha dealer charge the battery as soon as possible if it seems to have discharged. Keep in mind that the battery tends to discharge more quickly if the vehicle is equipped with optional electrical accessories.

To store the battery

1. If the vehicle will not be used for more than one month, remove the battery, fully charge it, and then place it in a cool, dry place.
2. If the battery will be stored for more than two months, check it at least once a month and fully charge it if necessary.
3. Fully charge the battery before installation.
4. After installation, make sure that the battery leads are properly connected to the battery terminals.

ECA10630

CAUTION:

- Always keep the battery charged. Storing a discharged battery can cause permanent battery damage.
- To charge a sealed-type (MF)

PERIODIC MAINTENANCE AND MINOR REPAIR

battery, a special (constant-voltage) battery charger is required. Using a conventional battery charger will damage the battery. If you do not have access to a sealed-type (MF) battery charger, have a Yamaha dealer charge your battery.

Replacing the fuse

EAU23502

ECA10640

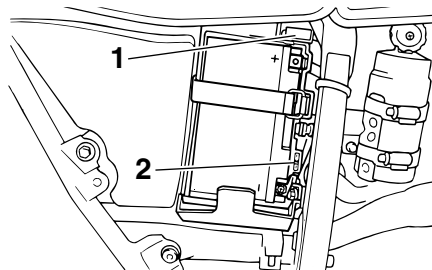

1. Fuse
2. Spare fuse

The fuse holder is located behind panel B. (See page 6-6.)

If the fuse is blown, replace it as follows.

1. Turn the key to “OFF” and turn off all electrical circuits.
2. Remove the blown fuse, and then install a new fuse of the specified amperage.

Specified fuse:
15.0 A

CAUTION:

Do not use a fuse of a higher amperage rating than recommended to avoid causing extensive damage to the electrical system and possibly a fire.

3. Turn the key to “ON” and turn on the electrical circuits to check if the devices operate.
4. If the fuse immediately blows again, have a Yamaha dealer check the electrical system.

PERIODIC MAINTENANCE AND MINOR REPAIR

EAU23841

Replacing the headlight bulb

This model is equipped with a quartz bulb headlight. If the headlight bulb burns out, replace it as follows.

1. Remove cowling A together with the headlight unit. (See page 6-6.)
2. Disconnect the headlight coupler, and then remove the bulb cover.

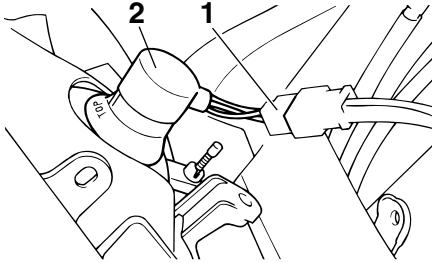

1. Headlight coupler
2. Headlight bulb cover
3. Remove the headlight bulb holder by pushing it inward and turning it counterclockwise, and then remove the defective bulb.

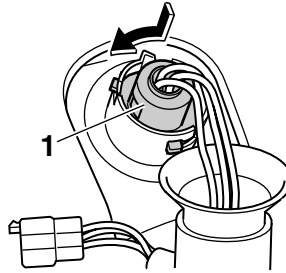

1. Headlight bulb holder

EWA10790

WARNING

Headlight bulbs get very hot. Therefore, keep flammable products away from a lit headlight bulb, and do not touch the bulb until it has cooled down.

4. Place a new headlight bulb into position, and then secure it with the bulb holder.

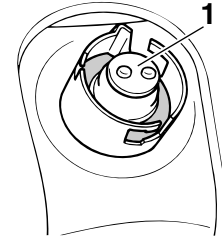

1. Headlight bulb

ECA10660

CAUTION:

Do not touch the glass part of the headlight bulb to keep it free from oil, otherwise the transparency of the glass, the luminosity of the bulb, and the bulb life will be adversely affected. Thoroughly clean off any dirt and fingerprints on the headlight bulb using a cloth moistened with alcohol or thinner.

PERIODIC MAINTENANCE AND MINOR REPAIR

EAU24191

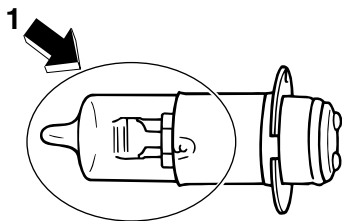

1. Do not touch the glass part of the bulb.
5. Install the headlight bulb cover, and then connect the coupler.
6. Install the cowling together with the headlight unit.
7. Have a Yamaha dealer adjust the headlight beam if necessary.

Replacing the taillight bulb

1. Remove the taillight lens by removing the screws.

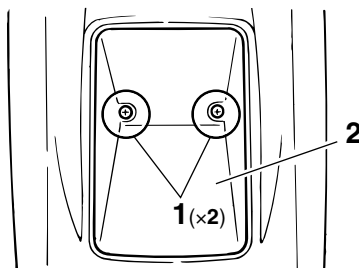

1. Screw
2. Taillight lens

2. Remove the defective bulb by pushing it in and turning it counter-clockwise.

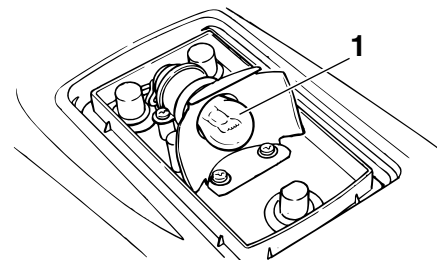

1. Bulb
3. Insert a new bulb into the socket, push it in, and then turn it clockwise until it stops.
4. Install the lens by installing the screws.

ECA10680

CAUTION:

Do not overtighten the screws, otherwise the lens may break.

PERIODIC MAINTENANCE AND MINOR REPAIR

EAU24350

Supporting the machine

Since this model is not equipped with a centerstand, follow these precautions when removing the front and rear wheel or performing other maintenance requiring the machine to stand upright. Check that the machine is in a stable and level position before starting any maintenance. A strong wooden box can be placed under the engine for added stability.

To service the front wheel

1. Stabilize the rear of the machine by using a machine stand or, if an additional machine stand is not available, by placing a jack under the frame in front of the rear wheel.
2. Raise the front wheel off the ground by using a machine stand.

To service the rear wheel

Raise the rear wheel off the ground by using a machine stand or, if a machine stand is not available, by placing a jack either under each side of the frame in front of the rear wheel or under each side of the swingarm.

EAU24360

Front wheel

EAU24670

To remove the front wheel

EWA10820

⚠ WARNING

- It is advisable to have a Yamaha dealer service the wheel.
- Securely support the machine so that there is no danger of it falling over.

1. Remove the tripmeter cable from the front wheel.
2. Loosen the wheel axle holder nuts, then the wheel axle.

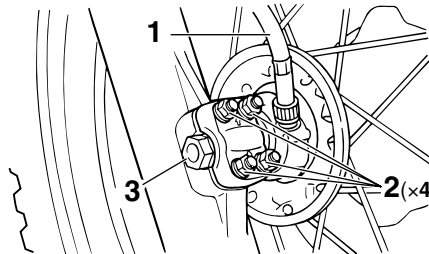

1. Tripmeter cable
2. Wheel axle holder nut
3. Wheel axle

3. Lift the front wheel off the ground according to the procedure on page 6-31.
4. Pull the wheel axle out, and then remove the wheel.

ECA11070

CAUTION:

Do not apply the brake after the wheel has been removed together with the brake disc, otherwise the brake pads will be forced shut.

EAU24961

To install the front wheel

1. Install the tripmeter gear unit into the wheel hub so that the projections mesh with the slots.

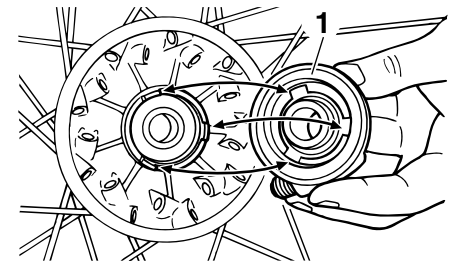

1. Tripmeter gear unit

PERIODIC MAINTENANCE AND MINOR REPAIR

2. Lift the wheel up between the fork legs.

NOTE: _____

Make sure that there is enough space between the brake pads before inserting the brake disc and that the slot in the tripmeter gear unit fits over the retainer on the fork leg.

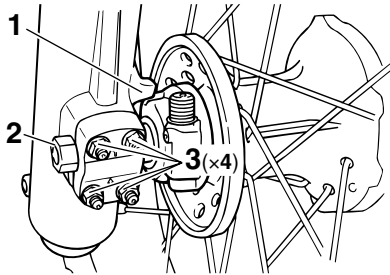

1. Retainer
2. Wheel axle
3. Wheel axle holder nut

3. Insert the wheel axle, and then tighten it to the specified torque.

Tightening torque:

Wheel axle:
58 Nm (5.8 m·kgf, 42 ft·lbf)

4. Tighten the wheel axle holder nuts to the specified torque.

NOTE: _____

Tighten the upper nuts first, and then the lower ones. When the nuts are tightened in this sequence, there should be a gap at the bottom of the axle holder.

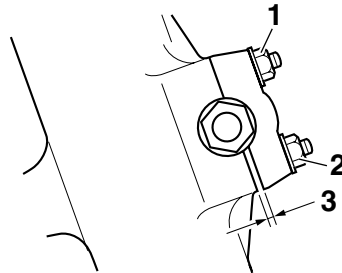

1. Upper nut
2. Lower nut
3. Gap

Tightening torque:

Wheel axle holder nut:
10 Nm (1.0 m·kgf, 7.2 ft·lbf)

5. While applying the front brake, push down hard on the handlebars several times to check if the front

fork compresses and rebounds smoothly.

6. Connect the tripmeter cable.

PERIODIC MAINTENANCE AND MINOR REPAIR

Rear wheel

EAU25080

EAU25280

EWA10820

To remove the rear wheel

WARNING

- It is advisable to have a Yamaha dealer service the wheel.
- Securely support the machine so that there is no danger of it falling over.

1. Remove the axle nut cotter pin, and then loosen the axle nut.

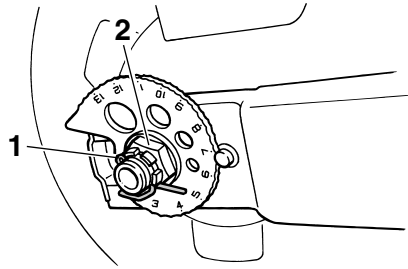

1. Axle nut cotter pin
2. Axle nut

2. Lift the rear wheel off the ground according to the procedure on

page 6-31.

3. Remove each swingarm end cover by removing the screws.

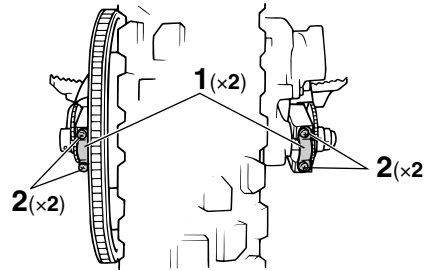

1. Swingarm end cover
2. Screw

4. Push the wheel forward, and then remove the drive chain from the rear sprocket.

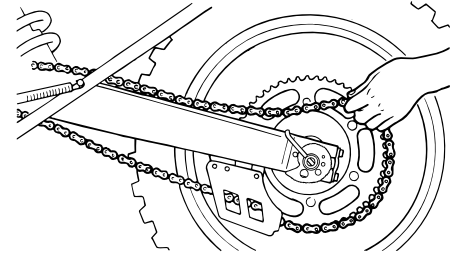

NOTE:

The drive chain does not need to be disassembled in order to remove and install the wheel.

5. Remove the wheel.

ECA11070

CAUTION:

Do not apply the brake after the wheel has been removed together with the brake disc, otherwise the brake pads will be forced shut.

EAU25630

To install the rear wheel

1. Install the wheel.

NOTE:

Make sure that there is enough space

PERIODIC MAINTENANCE AND MINOR REPAIR

between the brake pads before inserting the brake disc between the pads.

2. Install the drive chain onto the rear sprocket.
3. Install each swingarm end cover by installing the screws, and then lower the rear wheel so that it is on the ground.
4. Adjust the drive chain slack. (See page 6-21.)
5. Tighten the axle nut to the specified torque, and then install the cotter pin.

Tightening torque:

Axle nut:
105 Nm (10.5 m·kgf, 76 ft·lbf)

6



WARNING

Always use a new cotter pin for the axle nut.

EWA10700

EAU25850

Troubleshooting

Although Yamaha machines receive a thorough inspection before shipment from the factory, trouble may occur during operation. Any problem in the fuel, compression, or ignition systems, for example, can cause poor starting and loss of power.

The following troubleshooting chart represents a quick and easy procedure for checking these vital systems yourself. However, should your machine require any repair, take it to a Yamaha dealer, whose skilled technicians have the necessary tools, experience, and know-how to service the machine properly.

Use only genuine Yamaha replacement parts. Imitation parts may look like Yamaha parts, but they are often inferior, have a shorter service life and can lead to expensive repair bills.

PERIODIC MAINTENANCE AND MINOR REPAIR

EAU25901

Troubleshooting chart

EWA10840



Keep away open flames and do not smoke while checking or working on the fuel system.

1. Fuel

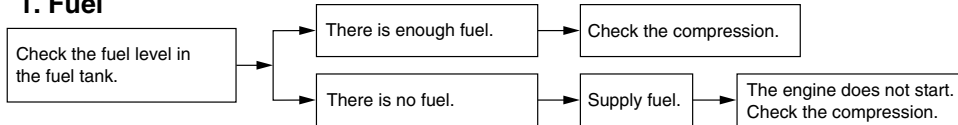

2. Compression

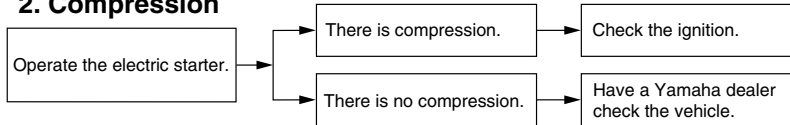

3. Ignition

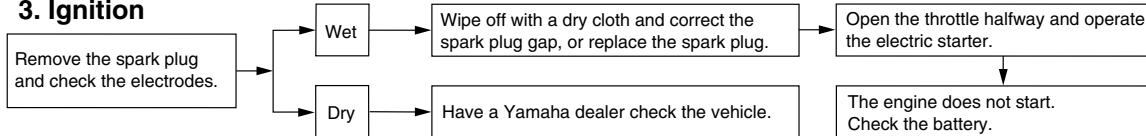

4. Battery

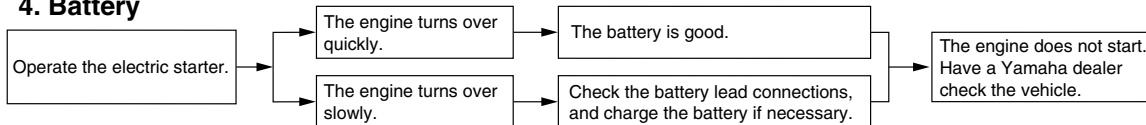

MACHINE CARE AND STORAGE

EAU26000

Care

While the open design of a machine reveals the attractiveness of the technology, it also makes it more vulnerable. Rust and corrosion can develop even if high-quality components are used. A rusty exhaust pipe may go unnoticed on a car, however, it detracts from the overall appearance of a machine. Frequent and proper care does not only comply with the terms of the warranty, but it will also keep your machine looking good, extend its life and optimize its performance.

Before cleaning

1. Cover the muffler outlet with a plastic bag after the engine has cooled down.
2. Make sure that all caps and covers as well as all electrical couplers and connectors, including the spark plug cap, are tightly installed.
3. Remove extremely stubborn dirt, like oil burnt onto the crankcase, with a degreasing agent and a brush, but never apply such prod-

ucts onto seals, gaskets, sprockets, the drive chain and wheel axles. Always rinse the dirt and degreaser off with water.

Cleaning

ECA10770

CAUTION:

- **Avoid using strong acidic wheel cleaners, especially on spoked wheels. If such products are used on hard-to-remove dirt, do not leave the cleaner on the affected area any longer than instructed. Also, thoroughly rinse the area off with water, immediately dry it, and then apply a corrosion protection spray.**
- **Improper cleaning can damage windshields, cowlings, panels and other plastic parts. Use only a soft, clean cloth or sponge with mild detergent and water to clean plastic.**
- **Do not use any harsh chemical products on plastic parts. Be sure to avoid using cloths or sponges which have been in contact with strong or abrasive**

cleaning products, solvent or thinner, fuel (gasoline), rust removers or inhibitors, brake fluid, antifreeze or electrolyte.

- **Do not use high-pressure washers or steam-jet cleaners since they cause water seepage and deterioration in the following areas: seals (of wheel and swing-arm bearings, fork and brakes), electric components (couplers, connectors, instruments, switches and lights), breather hoses and vents.**
 - **For machines equipped with a windshield: Do not use strong cleaners or hard sponges as they will cause dulling or scratching. Some cleaning compounds for plastic may leave scratches on the windshield. Test the product on a small hidden part of the windshield to make sure that it does not leave any marks. If the windshield is scratched, use a quality plastic polishing compound after washing.**
-

MACHINE CARE AND STORAGE

After normal use

Remove dirt with warm water, a mild detergent, and a soft, clean sponge, and then rinse thoroughly with clean water. Use a toothbrush or bottlebrush for hard-to-reach areas. Stubborn dirt and insects will come off more easily if the area is covered with a wet cloth for a few minutes before cleaning.

After riding in the rain, near the sea or on salt-sprayed roads

Since sea salt or salt sprayed on roads during winter are extremely corrosive in combination with water, carry out the following steps after each ride in the rain, near the sea or on salt-sprayed roads.

NOTE:

Salt sprayed on roads in the winter may remain well into spring.

1. Clean the machine with cold water and a mild detergent, after the engine has cooled down.

ECA10790

CAUTION:

Do not use warm water since it increases the corrosive action of the

salt.

2. Apply a corrosion protection spray on all metal, including chrome- and nickel-plated, surfaces to prevent corrosion.

After cleaning

1. Dry the machine with a chamois or an absorbing cloth.
2. Immediately dry the drive chain and lubricate it to prevent it from rusting.
3. Use a chrome polish to shine chrome, aluminum and stainless-steel parts, including the exhaust system. (Even the thermally induced discoloring of stainless-steel exhaust systems can be removed through polishing.)
4. To prevent corrosion, it is recommended to apply a corrosion protection spray on all metal, including chrome- and nickel-plated, surfaces.
5. Use spray oil as a universal cleaner to remove any remaining dirt.
6. Touch up minor paint damage caused by stones, etc.

7. Wax all painted surfaces.
8. Let the machine dry completely before storing or covering it.

EWA10930

⚠ WARNING

- **Make sure that there is no oil or wax on the brakes or tires. If necessary, clean the brake discs and brake linings with a regular brake disc cleaner or acetone, and wash the tires with warm water and a mild detergent.**
- **Before operating the machine test its braking performance and cornering behavior.**

ECA10800

CAUTION:

- **Apply spray oil and wax sparingly and make sure to wipe off any excess.**
- **Never apply oil or wax to any rubber and plastic parts, but treat them with a suitable care product.**
- **Avoid using abrasive polishing compounds as they will wear**

MACHINE CARE AND STORAGE

away the paint.

NOTE:

Consult a Yamaha dealer for advice on what products to use.

EAU26150

Storage

Short-term

Always store your machine in a cool, dry place and, if necessary, protect it against dust with a porous cover.

ECA10810

CAUTION:

- **Storing the machine in a poorly ventilated room or covering it with a tarp, while it is still wet, will allow water and humidity to seep in and cause rust.**
 - **To prevent corrosion, avoid damp cellars, stables (because of the presence of ammonia) and areas where strong chemicals are stored.**
-

Long-term

Before storing your machine for several months:

1. Follow all the instructions in the “Care” section of this chapter.
2. For machines equipped with a fuel cock that has an “OFF” position: Turn the fuel cock lever to “OFF”.

3. Drain the carburetor float chamber by loosening the drain bolt; this will prevent fuel deposits from building up. Pour the drained fuel into the fuel tank.
4. Fill up the fuel tank and add fuel stabilizer (if available) to prevent the fuel tank from rusting and the fuel from deteriorating.
5. Perform the following steps to protect the cylinder, piston rings, etc. from corrosion.
 - a. Remove the spark plug cap and spark plug.
 - b. Pour a teaspoonful of engine oil into the spark plug bore.
 - c. Install the spark plug cap onto the spark plug, and then place the spark plug on the cylinder head so that the electrodes are grounded. (This will limit sparking during the next step.)
 - d. Turn the engine over several times with the starter. (This will coat the cylinder wall with oil.)
 - e. Remove the spark plug cap from the spark plug, and then install the spark plug and the

spark plug cap.

EWA10950



To prevent damage or injury from sparking, make sure to ground the spark plug electrodes while turning the engine over.

6. Lubricate all control cables and the pivoting points of all levers and pedals as well as of the sidestand/centerstand.
7. Check and, if necessary, correct the tire air pressure, and then lift the machine so that both of its wheels are off the ground. Alternatively, turn the wheels a little every month in order to prevent the tires from becoming degraded in one spot.
8. Cover the muffler outlet with a plastic bag to prevent moisture from entering it.
9. Remove the battery and fully charge it. Store it in a cool, dry place and charge it once a month. Do not store the battery in an excessively cold or warm place [less than 0 °C (30 °F) or more

than 30 °C (90 °F)]. For more information on storing the battery, see page 6-27.

NOTE: _____
Make any necessary repairs before storing the machine.

SPECIFICATIONS

EAU2633D

Dimensions:

- Overall length:
2095 mm (82.5 in)
- Overall width:
835 mm (32.9 in)
- Overall height:
1260 mm (49.6 in)
- Seat height:
915 mm (36.0 in)
- Wheelbase:
1405 mm (55.3 in)
- Ground clearance:
305 mm (12.01 in)
- Minimum turning radius:
2200 mm (86.6 in)

Weight:

- With oil and fuel:
124.0 kg (273 lb)

Engine:

- Engine type:
Air cooled 4-stroke, DOHC
- Cylinder arrangement:
Forward-inclined single cylinder
- Displacement:
249.0 cm³ (15.19 cu.in)
- Bore × stroke:
73.0 × 59.6 mm (2.87 × 2.35 in)
- Compression ratio:
10.20 :1
- Starting system:
Electric starter
- Lubrication system:
Wet sump

Engine oil:

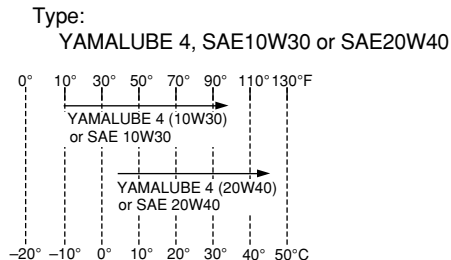

Engine oil quantity:

- Without oil filter element replacement:
1.10 L (1.16 US qt) (0.97 Imp.qt)
- With oil filter element replacement:
1.20 L (1.27 US qt) (1.06 Imp.qt)

Air filter:

- Air filter element:
Wet element

Fuel:

- Recommended fuel:
Unleaded gasoline only
- Fuel tank capacity:
9.5 L (2.51 US gal) (2.09 Imp.gal)
- Fuel reserve amount:
2.0 L (0.53 US gal) (0.44 Imp.gal)

Carburetor:

- Manufacturer:
TEIKEI
- Type × quantity:
Y30P × 1

Spark plug (s):

- Manufacturer/model:
NGK/CR9E
- Manufacturer/model:
DENSO/U27ESR-N
- Spark plug gap:
0.7–0.8 mm (0.028–0.031 in)

Clutch:

- Clutch type:
Wet, multiple-disc

Transmission:

- Primary reduction system:
Spur gear
- Primary reduction ratio:
74/24 (3.083)
- Secondary reduction system:
Chain drive
- Secondary reduction ratio:
52/13 (4.000)
- Transmission type:
Constant mesh 6-speed
- Operation:
Left foot operation

Gear ratio:

- 1st:
37/15 (2.467)
- 2nd:
29/16 (1.813)
- 3rd:
30/22 (1.364)
- 4th:
27/25 (1.080)

5th:
24/27 (0.889)
6th:
22/29 (0.759)

Chassis:

Frame type:
Semi double cradle
Caster angle:
26.00 °
Trail:
108.0 mm (4.25 in)

Front tire:

Type:
With tube
Size:
80/100-21 51M
Manufacturer/model:
DUNLOP/D739FA

Rear tire:

Type:
With tube
Size:
100/100-18 59M
Manufacturer/model:
DUNLOP/D739
Maximum load:
90 kg (198 lb)

* (Total weight of rider, passenger, cargo and accessories)

Tire air pressure (measured on cold tires):

Off-road riding:

Front:
100 kPa (15 psi) (1.00 kgf/cm²)
Rear:
100 kPa (15 psi) (1.00 kgf/cm²)

Front wheel:

Wheel type:
Spoke wheel
Rim size:
21x1.60

Rear wheel:

Wheel type:
Spoke wheel
Rim size:
18x2.15

Front brake:

Type:
Single disc brake
Operation:
Right hand operation
Recommended fluid:
DOT 4

Rear brake:

Type:
Single disc brake
Operation:
Right foot operation
Recommended fluid:
DOT 4

Front suspension:

Type:
Telescopic fork
Spring/shock absorber type:
Coil-air spring/oil damper
Wheel travel:
280.0 mm (11.02 in)

Rear suspension:

Type:
Swingarm (link suspension)
Spring/shock absorber type:
Coil spring/gas-oil damper
Wheel travel:
280.0 mm (11.02 in)

Electrical system:

Ignition system:
DC. CDI
Charging system:
AC magneto

Battery:

Model:
GT7B-4
Voltage, capacity:
12 V, 6.5 Ah

Headlight:

Bulb type:
Halogen bulb

Bulb voltage, wattage × quantity:

Headlight:
12 V, 35 W/36.5 W × 1
Tail/brake light:
12 V, 5.0 W/21.0 W × 1

SPECIFICATIONS

Fuse:

Fuse:

15.0 A

EAU26351

Identification numbers

Record the key identification number, vehicle identification number and model label information in the spaces provided below for assistance when ordering spare parts from a Yamaha dealer or for reference in case the vehicle is stolen.

KEY IDENTIFICATION NUMBER:

VEHICLE IDENTIFICATION NUMBER:

MODEL LABEL INFORMATION:

EAU26381

Key identification number

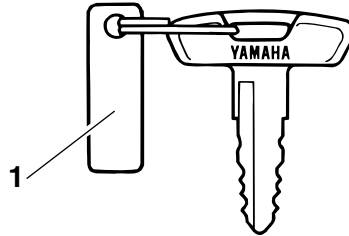

1. Key identification number

The key identification number is stamped into the key tag. Record this number in the space provided and use it for reference when ordering a new key.

EAU26400

Vehicle identification number

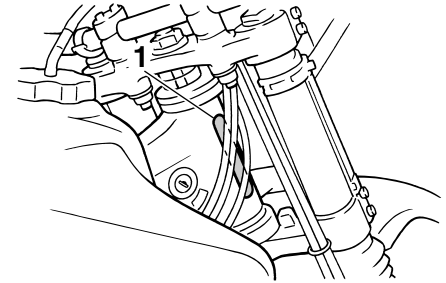

1. Vehicle identification number

The vehicle identification number is stamped into the steering head pipe. Record this number in the space provided.

NOTE: _____
The vehicle identification number is used to identify your machine and may be used to register your machine with the licensing authority in your area.

CONSUMER INFORMATION

EAU26480

Model label

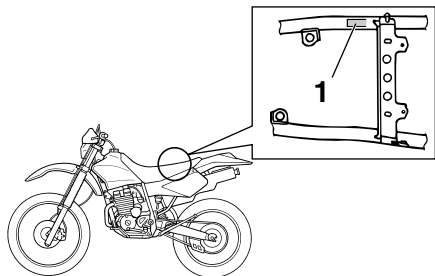

1. Model label

The model label is affixed to the frame under the seat. (See page 3-6.) Record the information on this label in the space provided. This information will be needed when ordering spare parts from a Yamaha dealer.

Motorcycle noise regulation

TAMPERING WITH NOISE CONTROL SYSTEM PROHIBITED:

Federal law prohibits the following acts or the causing thereof: (1) The removal or rendering inoperative by any person other than for purposes of maintenance, repair, or replacement of any device or element of design incorporated into any new vehicle for the purpose of noise control prior to its sale or delivery to the ultimate purchaser or while it is in use or (2) the use of the vehicle after such device or element of design has been removed or rendered inoperative by any person.

“AMONG THOSE ACTS PRESUMED TO CONSTITUTE TAMPERING ARE THE ACTS LISTED BELOW”.

These acts include tampering with the following systems; i.e., modification, removal, etc.

Exhaust system

- Muffler
- Exhaust pipe
- Silencer

Intake system

- Air cleaner case
- Air cleaner element
- Intake duct

CONSUMER INFORMATION

EAU26651

Maintenance record

Have a Yamaha dealer complete this record when the machine is serviced.

Maintenance interval	Date of service	Mileage	Servicing dealer name and address	Remarks

YAMAHA MOTOR CORPORATION, U.S.A. OFF-ROAD MOTORCYCLE LIMITED WARRANTY

Yamaha Motor Corporation, U.S.A. hereby warrants that each new Yamaha off-road motorcycle purchased from an authorized Yamaha motorcycle dealer in the continental United States will be free from defects in material and workmanship for the period of time stated herein, subject to certain stated limitations.

THE PERIOD OF WARRANTY for Yamaha off-road motorcycles shall be ninety (90) days from the date of purchase, with no mileage limitation.

MODELS EXCLUDED FROM WARRANTY include those used for non-Yamaha-authorized renting, leasing, or other commercial purposes.

DURING THE PERIOD OF WARRANTY any authorized Yamaha motorcycle dealer will, free of charge, repair or replace, at Yamaha's option, any part adjudged defective by Yamaha due to faulty workmanship or material from the factory. Parts used in warranty repairs will be warranted for the balance of the product's warranty period. All parts replaced under warranty become property of Yamaha Motor Corp. U.S.A.

GENERAL EXCLUSIONS from this warranty shall include any failures caused by:

- a. Competition or racing use (except TY models used for sanctioned trials).
- b. Installation of parts or accessories that are not qualitatively equivalent to genuine Yamaha parts.
- c. Abnormal strain, neglect, or abuse.
- d. Lack of proper maintenance.
- e. Accident or collision damage.
- f. Modification to original parts.

SPECIFIC EXCLUSIONS from this warranty shall include parts replaced due to normal wear or routine maintenance.

THE CUSTOMER'S RESPONSIBILITY under this warranty shall be to:

1. Operate and maintain the motorcycle as specified in the appropriate Owner's Manual, and
2. Give notice to an authorized Yamaha motorcycle dealer of any and all apparent defects within ten (10) days after discovery, and make the machine available at that time for inspection and repairs at such dealer's place of business.

WARRANTY TRANSFER: To transfer the warranty from the original purchaser to any subsequent purchaser, it is imperative that the machine be inspected and registered for warranty by an authorized Yamaha motorcycle dealer. In order for this warranty to remain in effect, this inspection and registration must take place within ten (10) days after transfer. An inspection and registration fee will be charged for this service.

YAMAHA MOTOR CORPORATION, U.S.A. MAKES NO OTHER WARRANTY OF ANY KIND, EXPRESSED OR IMPLIED. ALL IMPLIED WARRANTIES OF MERCHANTABILITY AND FITNESS FOR A PARTICULAR PURPOSE WHICH EXCEED THE OBLIGATIONS AND TIME LIMITS STATED IN THIS WARRANTY ARE HEREBY DISCLAIMED BY YAMAHA MOTOR CORPORATION, U.S.A. AND EXCLUDED FROM THIS WARRANTY.

SOME STATES DO NOT ALLOW LIMITATIONS ON HOW LONG AN IMPLIED WARRANTY LASTS, SO THE ABOVE LIMITATION MAY NOT APPLY TO YOU. ALSO EXCLUDED FROM THIS WARRANTY ARE ANY IN-

CIDENTAL OR CONSEQUENTIAL DAMAGES INCLUDING LOSS OF USE. SOME STATES DO NOT ALLOW THE EXCLUSION OR LIMITATION OF INCIDENTAL OR CONSEQUENTIAL DAMAGES, SO THE ABOVE EXCLUSION MAY NOT APPLY TO YOU.

THIS WARRANTY GIVES YOU SPECIFIC LEGAL RIGHTS, AND YOU MAY ALSO HAVE OTHER RIGHTS WHICH VARY FROM STATE TO STATE.

YAMAHA MOTOR CORPORATION, U.S.A.
P. O. Box 6555
Cypress, California 90630

CONSUMER INFORMATION

WARRANTY QUESTIONS AND ANSWERS

- Q. What costs are my responsibility during the warranty period?
- A. The customer's responsibility includes all costs of normal maintenance services, non-warranty repairs, accident and collision damages, and oil, oil filters, air filters, spark plugs, and brake shoes.
- Q. What are some examples of "abnormal" strain, neglect, or abuse?
- A. These terms are general and overlap each other in areas. Specific examples include: Running the machine out of oil, sustained high-rpm, full-throttle, operating the machine with a broken or damaged part which causes another part to fail, damage or failure due to improper or careless transportation and or tie down. If you have any specific questions on operation or maintenance, please contact your dealer for advice.
- Q. Does the warranty cover incidental costs such as towing or transportation due to a failure?
- A. No. The warranty is limited to repair of the machine itself.
- Q. May I perform any or all of the recommended maintenance shown in the Owner's Manual instead of having the dealer do them?
- A. Yes, if you are a qualified mechanic and follow the procedures specified in the Owner's and Service Manual. We do recommend, however, that items requiring special tools or equipment be done by Yamaha Motorcycle dealer.
- Q. Will the warranty be void or cancelled if I do not operate or maintain my new motorcycle exactly as specified in the Owner's Manual?
- A. No. The warranty on a new motorcycle cannot be "voided" or "cancelled." **However, if a particular failure is caused by operation or maintenance other than as shown in the Owner's Manual, that failure may not be covered under warranty.**
- Q. What responsibility does my dealer have under this warranty?
- A. Each Yamaha Motorcycle dealer is expected to:
1. Completely set up every new machine before sale.
 2. Explain the operation, maintenance, and warranty requirements to your satisfaction at the time of sale, and upon your request at any later date.
 3. Each Yamaha Motorcycle dealer is held responsible for his setup, service and warranty repair work.
- Q. Is the warranty transferable to second owners?
- A. Yes. The remainder of the existing warranty can be transferred upon request. The unit has to be inspected and re-registered by an authorized Yamaha Motorcycle dealer for the policy to remain effective.

CUSTOMER SERVICE

If your machine requires warranty service, you must take it to any authorized Yamaha Motorcycle dealer within the continental United States. Be sure to bring your warranty registration card or other valid proof of the original date of purchase. If a question or problem arises regarding warranty, first contact the owner of the dealership. Since all warranty matters are handled at the dealer level, this person is in the best position to help you. If you are still not satisfied and require additional assistance, please write:

YAMAHA MOTOR CORPORATION U.S.A.
CUSTOMER RELATIONS DEPARTMENT
P.O. Box 6555
Cypress, California 90630

When contacting Yamaha Motor Corporation, U.S.A. don't forget to include any important information such as names, addresses, model, V.I.N. (frame number), dates, and receipts.

CHANGE OF ADDRESS

The federal government requires each manufacturer of a motor vehicle to maintain a complete, up-to-date list of all first purchasers against the possibility of a safety-related defect and recall. This list is compiled from the purchase registrations sent to Yamaha Motor Corporation, U.S.A. by the selling dealer at the time of your purchase.

If you should move after you have purchased your new motorcycle, please advise us of your new address by sending a postcard listing your motorcycle model name, V.I.N. (frame number), dealer number (or dealer's name) as it is shown on your warranty card, your name and new mailing address. Mail to:

YAMAHA MOTOR CORPORATION, U.S.A.
P.O. Box 6555
Cypress, California 90630
Attention: Warranty Department

This will ensure that Yamaha Motor Corporation, U.S.A. has an up-to-date registration record in accordance with federal law.

YAMAHA EXTENDED SERVICE (Y.E.S.)

Keep your Yamaha protected even after your warranty expires with genuine Yamaha Extended Service (Y.E.S.).

- Y.E.S. is designed and administered by Yamaha Motor Corporation to provide maximum owner satisfaction. You get uninterrupted factory-backed coverage for extra peace of mind.
 - Y.E.S. is flexible. You choose the plan that's right for you: 12 months, 24 months, 36 months or, on certain models, even 48 months beyond your warranty period.
 - Y.E.S. is designed and administered by the same Yamaha people who handle your warranty – and it shows in the comprehensive coverage benefits. There are no mileage limitations. Coverage isn't limited to "moving parts" or the "drive train" like many other plans. And Y.E.S. covers manufacturing defects just like the warranty. See the sample contract at your Yamaha dealer to see how comforting uninterrupted factory-backed protection can be.
 - You don't have to pay anything for covered repairs. There's no deductible to pay, and repairs aren't "pro-rated." You don't have any "out-of-pocket" expenses for covered repairs.
- In addition, Travel and Recreation Interruption Protection (TRIP) is included at no extra cost. TRIP gives you up to \$150 reimbursement per occurrence for any reasonable expenses you incur because your Yamaha needs covered service: replacement vehicle rental, emergency towing, phone calls, even food and lodging when you are away from home. This superb coverage goes into effect when you purchase Y.E.S., so it applies to any warranty repairs as well as covered repairs during your entire Y.E.S. plan period.
 - Y.E.S. coverage is honored at any authorized Yamaha dealer nationwide.
 - Y.E.S. coverage is transferable to a new owner if you sell or trade-in. That can make your Yamaha much more valuable!

This excellent Y.E.S. plan coverage is only available to Yamaha owners like you, and only while your Yamaha is still within the Yamaha Limited Warranty period. So visit your authorized Yamaha dealer to get all the facts. He can show you how easy it is to protect your investment with Yamaha Extended Service.

CONSUMER INFORMATION

We urge you to act now. You'll get the excellent benefits of TRIP coverage right away, and you'll rest easy knowing you'll have strong factory-backed protection even after your Yamaha Limited Warranty expires.

A special note:

If visiting your dealer isn't convenient, contact Yamaha with your Primary ID number (your frame number). We'll be happy to help you get the Y.E.S. coverage you need.

Yamaha Service Marketing

P.O. Box 6555

Cypress, CA 90630

1-(866)-YES-EXTD (1-866-937-3983)



YAMAHA



EXTENDED



SERVICE

- A**
 Accessories and replacement parts 6-17
 Air filter element, cleaning 6-12
- B**
 Battery 6-27
 Brake and clutch levers, checking and lubricating 6-24
 Brake fluid, changing 6-21
 Brake fluid level, checking 6-20
 Brake lever 3-3
 Brake lever free play, adjusting 6-19
 Brake pedal 3-3
 Brake pedal, lubricating 6-24
- C**
 Cables, checking and lubricating 6-23
 Carburetor 6-14
 Care 7-1
 Cleaning the spark arrester 6-13
 Clutch lever 3-2
 Clutch lever free play, adjusting 6-18
 Cowling and panels, removing and installing 6-6
- D**
 Drive chain, cleaning and lubricating 6-23
 Drive chain slack 6-21
- E**
 Engine break-in 5-3
 Engine oil and oil filter element 6-8
 Engine, starting a warm 5-2
 Engine stop switch 3-2
- F**
 Front and rear brake pads, checking 6-19
 Front fork, adjusting 3-7
 Front fork, checking 6-25
- Fuel 3-4
 Fuel cock 3-5
 Fuel tank breather hose 3-5
 Fuel tank cap 3-3
 Fuse, replacing 6-28
- H**
 Handlebar switches 3-1
 Headlight bulb, replacing 6-29
- I**
 Identification numbers 9-1
- K**
 Key identification number 9-1
- L**
 Labels, location of 1-5
 Light switch 3-2
- M**
 Main switch 3-1
 Maintenance and lubrication, periodic 6-3
 Maintenance, emission control system 6-2
 Maintenance record 9-4
 Model label 9-2
- N**
 Noise regulation 9-3
- P**
 Parking 5-3
 Part locations 2-1
 Pre-operation check list 4-2
- S**
 Safety information 1-1
 Seat 3-6
 Shifting 5-2
 Shift pedal 3-2
 Shock absorber assembly, adjusting 3-9
- Sidestand, checking and lubricating 6-25
 Spark plug, checking 6-7
 Specifications 8-1
 Starter (choke) knob 3-6
 Starting and warming up a cold engine 5-1
 Starting circuit cut-off system 3-11
 Start switch 3-2
 Steering, checking 6-26
 Storage 7-3
 Supporting the machine 6-31
- T**
 Taillight bulb, replacing 6-30
 Throttle cable free play, checking 6-14
 Throttle grip and cable, checking and lubricating 6-24
 Tires 6-15
 Tool kit 6-1
 Tripmeter 3-1
 Troubleshooting 6-34
 Troubleshooting chart 6-35
- V**
 Valve clearance 6-15
 Vehicle identification number 9-1
- W**
 Warranty, extended 9-7
 Warranty, limited 9-5
 Wheel bearings, checking 6-26
 Wheel (front) 6-31
 Wheel (rear) 6-33
 Wheels 6-17

***PROTECT YOUR INVESTMENT
Use Genuine YAMAHA Parts And Accessories.***

***See your Authorized YAMAHA Dealer for a Genuine YAMAHA
Service Manual.***



YAMAHA MOTOR CO., LTD.

PRINTED ON RECYCLED PAPER

PRINTED IN JAPAN
2005.5-1.1×1 
(E)